



01-22-03 - Late Production - Update Programming Engine/Motor Control Module -J623-

Release date: 3/29/2022

## Condition

Applicable Vehicles					
Model(s)	Year	Eng. Code	Trans. Code	VIN Range From	VIN Range To
Jetta	2020 - 2021	1.4T DGXA	All	All	All

Revision Table			
Instance Number	Published Date	Version Number	Reason For Update
2066602/1	3/29/22	01-22-03	Original publication.

Customer states there is low or no heat output from the air vents under certain cold weather conditions. This TB also proactively corrects faults listed below.



**Tip:**

This software update also includes modification for: P0441, P04F0, P148D, P0496, P060C (37682), P013E, P30DC and P2421 DTCs.

One or more of the following fault codes may be stored in the Engine Control Module (ECM) Fault Memory:

DTC	Description
P0441	EVAP Emission Contr.Sys.Incorrect Purge Flow
P04F0	EVAP system high pressure purge line performance
P148D	Evaporative Emission System Leak Detection Pump implausible frequency
P0496	EVAP System High Purge Flow
P060C (37682)	Internal Control Module Main Processor Performance
P013E	O2 Sensor Bank 1 Sensor 2 Delayed Response - Rich to Lean
P30DC	Pressure release for refueling gas tank not possible



01-22-03 - Late Production - Update Programming Engine/Motor Control Module -J623-

Release date: 3/29/2022

P2421 (MAY also require part replacement with ECM flash - see below)	Evaporative Emission System Vent Valve Stuck Open
--	---

**Note:**

**DO NOT** diagnose or replace components due to P0441, P04F0, P148D, P0496, P060C (37682), P013E, P30DC and P2421 faults **before** performing the update function as explained in this bulletin.

## Technical Background

Current Engine/Motor Control Module -J623- software can cause low engine heat output or may lead to various fault codes within the vehicle.

## Production Solution

Improved Engine/Motor Control Module -J623- software.

## Service

### Update-Programming Procedure:

**Critical Warning:** : The Midtronics battery charger **must** be connected to the vehicle battery for the duration of the programming, to ensure the battery state of charge remains above 12.5 volts during the update process. If the battery drops below 12.5 volts, the programming could fail which may result in damage to the control module. Control modules damaged by inadequate voltage will not be covered under the warranty policy. The technician should verify the vehicle voltage prior to starting the update process, and should monitor the voltage for the duration of the update.

The procedure may cancel itself if the hazard warning lights are not switched ON. The hazard warning lights prevent the system from switching to bus sleep mode during the update.

ODIS-Service tester should be updated to the latest GFF technical version 9.0.1 or higher and SW version 2.44.1 or higher.

**WARNING:**

Radiator Fan(s) may cycle ON high speed during the Update Process! There is a risk that personal injury may result if contact is made with spinning fan blades.

Keep hands and all objects away from Radiator Fan(s) during Update Process!



01-22-03 - Late Production - Update Programming Engine/Motor Control Module -J623-

Release date: 3/29/2022



**Note:**

Prior to launching the ODIS Service diagnostic applications and starting control module update process, confirm tester screen saver and power settings in accordance with Diagnostic Device Hardware & Windows® - VHW-20-02 Change Power Options After Windows®10 Upgrade. Failure to do so may result in the tester entering power save mode during data transfer, and subsequent control module failure. When using a VAS 6150/X or 6160/X tester in conjunction with a VAS 6154 wireless transmitter head for a flash procedure, connect a USB cable between the transmitter head and the tester. Failure to do so may lead to errors during the flash procedure.

VAS tools must only be used with their power adapters plugged in. Under no circumstances should they be used on battery power alone during the programming procedure.



**Tip:**

To Update-Programming using Software Version Management (SVM), **review and follow** instructions in **Technical Bulletin Instance 2014603** "Software Version Management".

The SVM process must be completed in its entirety so the database receives the update confirmation response. A warranty claim may not be reimbursed if there is no confirmation response to support the claim or action is carried out that is not explicitly stated in the Technical Bulletin.

- Update the Engine Control Module using the SVM Unit code as listed in the table below:

Model	Engine	Old Software Part No.	Old Software Version	New Software Part No.	New Software Version (or higher)	SVM Unit Code
Jetta	DGXA	04E 906 024 AB	Z842 6946 9944 9970 9971 9972	04E 906 024 AB	9973	48A2
Jetta	DGXA	04E 906 024 BC	946 9970 9971 9972	04E 906 024 BC	9973	48A2



01-22-03 - Late Production - Update Programming Engine/Motor Control Module -J623-

Release date: 3/29/2022

Jetta	DGXA	04E 906 024 BB	7401 9945 9970 9971 9972	04E 906 024 BB	9973	48A2
Jetta	DGXA	04E 906 024 BJ	Z943 Z961 0907 1055 2049	04E 906 024 BJ	2326	48A2
Jetta	DGXA	04E 906 024 BG	Z943 Z961 0905 1057 1520	04E 906 024 BG	2324	48A2
Jetta	DGXA	04E 906 024 BH	Z943 Z961 0906 1056 2048	04E 906 024 BH	2325	48A2

The procedure can be found in GFF under Functions/ Component Selection, Software Version Management, Adapting Software.



**Tip:**

The procedure can be found in GFF under Functions/ Component Selection, Software Version Management, Adapting Software.

Ensure attached ECM/TCM Tuning Form has been completed and signed by customer as required in SVM Technical Bulletin Instance 2014603.



01-22-03 - Late Production - Update Programming Engine/Motor Control Module -J623-

Release date: 3/29/2022

---

**For VINs setting fault code P2421:**

In addition to the software improvement, there is also an improvement to the FTIV (fuel tank isolation valve/tank switch-off valve -**N288**-) (Figure 1.), which is necessary in preventing erroneous occurrences of the P2421 fault code.

The FTIV / Tank switch-off valve -**N288**- currently installed on the vehicle must be inspected, to verify whether an improved part has already been installed. The FTIV / Tank switch-off valve -**N288**- is mounted to the EVAP canister assembly, as shown below.

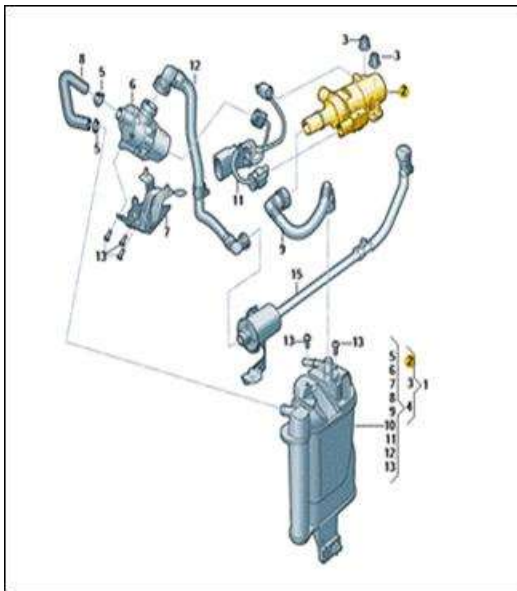

Figure 1.

Remove the EVAP canister assembly and inspect the face of the FTIV / Tank switch-off valve -**N288**-. If the part is already updated, it will have a white paint marking or "02S" printed after the part number, as shown in Figure 2 and Figure 3.

- If the part has a white paint mark or "02S", the FTIV / Tank switch-off valve -**N288**- is already the updated component. In this case DO NOT replace it, and instead reinstall the EVAP canister assembly. Only the software update will be required.
- If there is no white paint mark or "02S" are visible on the FTIV / Tank switch-off valve -**N288**-, the component must also be replaced in addition to the software update. Always refer to ETKA for the most up to date part number information.



01-22-03 - Late Production - Update Programming Engine/Motor Control Module -J623-

Release date: 3/29/2022

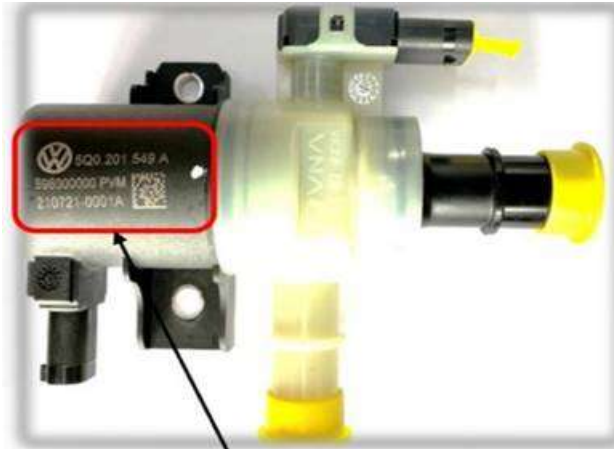

Figure 2.



Figure 3.

## Warranty

To determine if this procedure is covered under Warranty, always refer to the Warranty Policies and Procedures Manual <sup>1)</sup>

Model(s)	Year(s)	Eng. Code(s)	Trans. Code(s)	VIN Range From	VIN Range To
Jetta	2020 - 2021	1.4T DGXA	All	All	All
<b>SAGA Coding</b>					
<b>Claim Type:</b>	<b>Use applicable Claim Type <sup>1)</sup></b>				
<b>Service Number:</b>	<b>Damage Code</b>	<b>HST</b>	<b>Damage Location (Depends on Service No.)</b>		
2470	0039	--	--		
<b>Parts Manufacturer</b>	Jetta		3ME <sup>2)</sup>		
<b>Original Part Number:</b>	5Q0 201 541 A				
<b>Original Part Supplier Name:</b>	Padmini				



01-22-03 - Late Production - Update Programming Engine/Motor Control Module -J623-

Release date: 3/29/2022

<b>Labor Operation</b> <sup>3)</sup> : Charge Battery		27068950 = See Elsa for latest time units.
<b>Labor Operation</b> <sup>3)</sup> : Update Programming ECM Control Module		24705599 = 50 TU max.
<b>Labor Operation</b> <sup>3)</sup> : Activated charcoal filter rem+reins <b>(Only for vehicle with DTC P2421)</b>		20251900 = See Elsa for latest time units.
<b>Labor Operation</b> <sup>3)</sup> : Replace FTIV / Tank switch-off valve -N288- <b>(Only for vehicle with DTC P2421)</b>		20711950 = See Elsa for latest time units.
<b>Causal Part:</b>		24705599
<b>Diagnostic Time</b> <sup>4)</sup>		
<b>GFF Time expenditure</b>	01500000 = Actual GFF print out	NO
<b>Road Test</b>	01210004 = 10 TU	YES
<b>Technical Diagnosis</b>	01320000 = 00 TU max.	NO
<b>Claim Comment:</b> Input "As per Technical Bulletin 2066602" in comment section of Warranty Claim.		
<p><sup>1)</sup> Vehicle may be outside any Warranty in which case this Technical Bulletin is informational only.</p> <p><sup>2)</sup> Code per warranty vendor code policy.</p> <p><sup>3)</sup> Labor Time Units (TUs) are subject to change with ELSA updates.</p> <p><sup>4)</sup> Documentation required per Warranty Policies and Procedures Manual.</p>		

### Required Parts and Tools

Part No:	Part Description	Quantity
5Q0201549A PAX <b>(Only for P2421 if required)</b>	Pressure Regulation Valve (Crystal Gray) / - <b>N288-</b>	1

Tool Description	Tool No:
Midtronics Battery Tester/Charger	GRX3000VAS or MTRMSP0702 battery maintainer/charger



01-22-03 - Late Production - Update Programming Engine/Motor  
Control Module -J623-

Release date: 3/29/2022

VAS Diagnostic Tool	VAS 6150/X & VAS 6160/X and ODIS Service with current online updates
---------------------	---

### Additional Information

All part and service references provided in this Technical Bulletin are subject to change and/or removal. Always check with your Parts Dept. and Repair Manuals for the latest information.





**OWNER INFORMATION ABOUT CONTROL MODULE TUNING\*  
ACKNOWLEDGEMENT AND AUTHORIZATION FOR  
REPROGRAMMING (REFLASHING) OF CONTROL MODULE(S)**

\*) "TUNING" is described as the addition of or modification of any component which causes a Volkswagen vehicle to perform outside the normal parameters and specifications approved by Volkswagen Group of America / Volkswagen Group Canada.

**Date:** \_\_\_\_\_  
**Dealer Number:** \_\_\_\_\_  
**Vehicle Identification Number:** \_\_\_\_\_  
**Repair Order Number:** \_\_\_\_\_

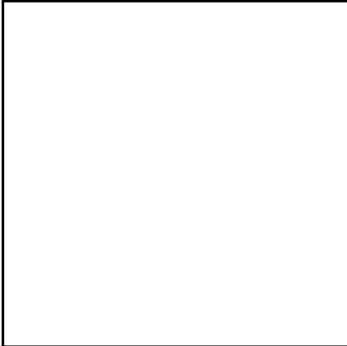

Dealer stamp

I \_\_\_\_\_, owner or driver of the above identified Volkswagen, confirm:

- "Tuning" as described above (especially power increasing modifications) has NOT been performed on my vehicle.
- "Tuning" as described above has been performed on my vehicle and the following components were modified or installed:

\_\_\_\_\_  
 \_\_\_\_\_  
TUNING was performed by (Please provide Company name and telephone number, if you wish us to contact them):  
 \_\_\_\_\_

I understand that if my Control Module is determined to have been tuned, any damage caused by the tuning of the Control Module (including adverse emissions consequences) will not be covered by VWGoA / VGC warranties.

I am permitting an authorized Volkswagen Dealer to reflash (update) my Control Module, and by doing so, I understand that this process will automatically overwrite (destroy) and permanently delete any tuning program that was previously installed on the Control Module of my Volkswagen vehicle.

By signing below, I fully acknowledge and understand that the tuning program will not be restored and VWGoA / VGC, will not be liable in any way for the loss of tuning data.

\_\_\_\_\_  
 Signature of Customer