

March 2022
SF648A

Subject: Western Star 47X and 49X SBA Front Suspension Shackle Bolts

Models Affected: Specific model years 2021-2022 Western Star 47X and 49X model vehicles manufactured February 10, 2020, through December 14, 2021.

General Information

Daimler Truck North America LLC (DTNA), on behalf of its wholly owned subsidiary, Western Star Trucks Inc., is initiating Field Service Campaign SF648 to modify the vehicles mentioned above.

On certain vehicles, the front suspension shackle bar may have a deformed spring pin hole due to lack of clamp load at the spring pin joint, causing a decrease in joint clamp load and movement of the spring pin.

The front suspension shackle bolts will be removed and replaced with front suspension shackle bolts that provide the correct front clamp load.

There are approximately 1,135 vehicles involved in this campaign.

Additional Repairs

Dealers must complete all outstanding Recall and Field Service campaigns prior to the sale or delivery of a vehicle. A Dealer will be liable for any progressive damage that results from its failure to complete campaigns before sale or delivery of a vehicle.

Owners may be liable for any progressive damage that results from failure to complete campaigns within a reasonable time after receiving notification.

Please contact Warranty Campaigns for consideration of additional charges prior to performing the repair.

Work Instructions

Please refer to the attached work instructions. Prior to performing the campaign, check the vehicle for a completion sticker (Form WAR261).

Replacement Parts

Replacement parts are now available and can be obtained by ordering the part number(s) listed below from your facing Parts Distribution Center.

If our records show your dealership has ordered any vehicle(s) involved in campaign number SF648, a list of the customers and vehicle identification numbers will be available on DTNAConnect. Please refer to this list when ordering parts for this campaign.

Table 1 - Replacement Parts for SF648

Campaign Number	Part Description	Part Number	Qty.
SF648A	SCREW-CAP,HEX,1/2-13,GR8PO	23-09440-300	8 ea
	NUT-HEX,LKG,XL SIL,1/2-13	23-13833-108	8 ea
	WASHER-HRDN,0.53X1.06X.177,ZN	23-09114-003	16 ea
	BLANK COMPLETION STICKER	WAR261	1 ea

Table 1

Removed Parts

U.S. and Canadian Dealers, please follow Warranty Failed Parts Tracking shipping instructions for the disposition of all removed parts. Export distributors, please destroy removed parts unless otherwise advised.

March 2022
SF648A

Labor Allowance

Table 2 - Labor Allowance

Campaign Number	Procedure	Time Allowed (hours)	SRT Code	Corrective Action
SF648A	Remove and replace front shackle bolts	1.7	996-F120A	12-Repair Recall/Campaign

Table 2

IMPORTANT: When the campaign has been completed, locate the base completion label in the appropriate location on the vehicle, and attach the gray completion sticker provided in the field service kit (Form WAR261). If the vehicle does not have a base completion label, clean a spot on the appropriate location of the vehicle and first attach the base completion label (Form WAR259). If a field service kit is not required or there is no completion sticker in the kit, write the campaign number on a blank sticker and attach it to the base completion label.

Claims for Credit

You will be reimbursed for your parts, labor, and handling (landed cost for Export Distributors) by submitting your claim through the Warranty system within 30 days of completing this campaign. Please reference the following information in OWL:

- Claim type is **Field Service Campaign**.
- In the Campaign field, enter the campaign number and appropriate condition code (**SF648-A**).
- In the Primary Failed Part field, enter **25-SF648-000**.
- In the Parts section, enter the appropriate part number(s) as shown in the Replacement Parts Table.
- In the Labor section, enter the appropriate SRT from the Labor Allowance Table. Administrative time will be included automatically as SRT 939-6010A for 0.3 hours.
- The VMRS Component Code is **F99-999-005** and the Cause Code is **A1 - Campaign**.
- This Field Service Campaign will **terminate on March 31, 2023**. Dealers will be notified of any changes to the termination date via an Important Campaign Information Letter posted on DTNAConnect.com.

IMPORTANT: OWL must be viewed prior to beginning work to ensure the vehicle is involved and the campaign has not previously been completed. Also, check for a completion sticker before beginning work.

All claims must be submitted within 30 days of the repair and within 30 days of the termination date of the campaign. U.S. and Canadian Dealers: All excess inventory to be returned to the PDC following the conclusion of the campaign must be returned in resaleable condition to the Memphis PDC within 90 days from the termination date. Please submit a PAR to request return to the Memphis PDC. (Canadian dealers should return the inventory to their facing PDC.) Export Distributors: Excess inventory is not returnable.

For questions, U.S. and Canadian dealers, contact the Warranty Campaigns Department via Web inquiry at DTNAConnect.com/WSC, or the Customer Assistance Center at (800) 385-4357, if you have any questions or need additional information. Export Distributors: submit a Web inquiry or contact your International Service Manager.

March
SF648A

Copy of Notice to Owners

Subject: Western Star 47X and 49X SBA Front Suspension Shackle Bolts

Daimler Truck North America LLC (DTNA), on behalf of its wholly owned subsidiary, Western Star Trucks Inc., is initiating Field Service Campaign SF648 to modify specific model years 2021-2022 Western Star 47X and 49X model vehicles manufactured February 10, 2020, through December 14, 2021.

On certain vehicles, the front suspension shackle bar may have a deformed spring pin hole due to lack of clamp load at the spring pin joint, causing a decrease in joint clamp load and movement of the spring pin.

The front suspension shackle bolts will be removed and replaced with front suspension shackle bolts that provide the correct front clamp load.

Please contact an authorized DTNA dealer to arrange to have the campaign performed and to ensure that parts are available at the dealership. The campaign will take approximately two hours and will be performed at no charge to you. To locate an authorized dealer, search online at NorthAmerica.Daimlertruck.com/contact-us/. Scroll down to "Locate a Dealer," and select the appropriate brand.

This Field Service Campaign will **terminate on March 31, 2023**. Please make sure the campaign is completed prior to this date. Work completed after this date will be done at the customer's expense.

As stated in the terms of your express limited warranty, DTNA will not pay for any damage caused by failure to properly maintain your vehicle. DTNA considers the work necessary under this campaign to be proper maintenance and will, therefore, not pay for any damage to your vehicle caused by your failure to have the repairs that are the subject of this campaign performed in a reasonable time.

Contact the Warranty Campaigns Department at (800) 547-0712, from 7 a.m. to 4 p.m. Pacific Time, Monday through Friday, e-mail address DTNA.Warranty.Campaigns@Daimlertruck.com, or the Customer Assistance Center at (800) 385-4357, if you have any questions or need additional information.

WARRANTY CAMPAIGNS DEPARTMENT

Enclosure

March 2022
SF648A

Work Instructions

Subject: Western Star 47X and 49X SBA Front Suspension Shackle Bolts

Models Affected: Specific model years 2021-2022 Western Star 47X and 49X model vehicles manufactured February 10, 2020, through December 14, 2021.

Front Suspension Shackle Bolts Replacement

1. Check the base label (Form WAR259) for a completion sticker for SF648 (Form WAR261) indicating this work has been done. The base label is usually located on the passenger door about 12 inches (30 cm) below the door latch. If a sticker is present, no work is needed. If there is no sticker, proceed with the next step.
2. Park the vehicle on a level surface, shut down the engine, and apply the parking brakes. Chock the tires.

WARNING

Never work around or under a vehicle that is supported only by a jack. Always support the vehicle with safety stands. Jacks can slip, allowing the vehicle to fall, which could result in serious injury or death.

3. Raise the vehicle until both front tires are off the ground, then support the frame with safety stands. For instructions to raise and lower the vehicle, see **Group 00** of the *47X and 49X Workshop Manual*.
4. Using a floor jack, raise the front axle just enough so the jack is supporting the weight of the axle, then support the axle with safety stands.
5. On one side of the vehicle, remove the four M12 shackle link retaining bolts and discard them. See **Fig. 1**.

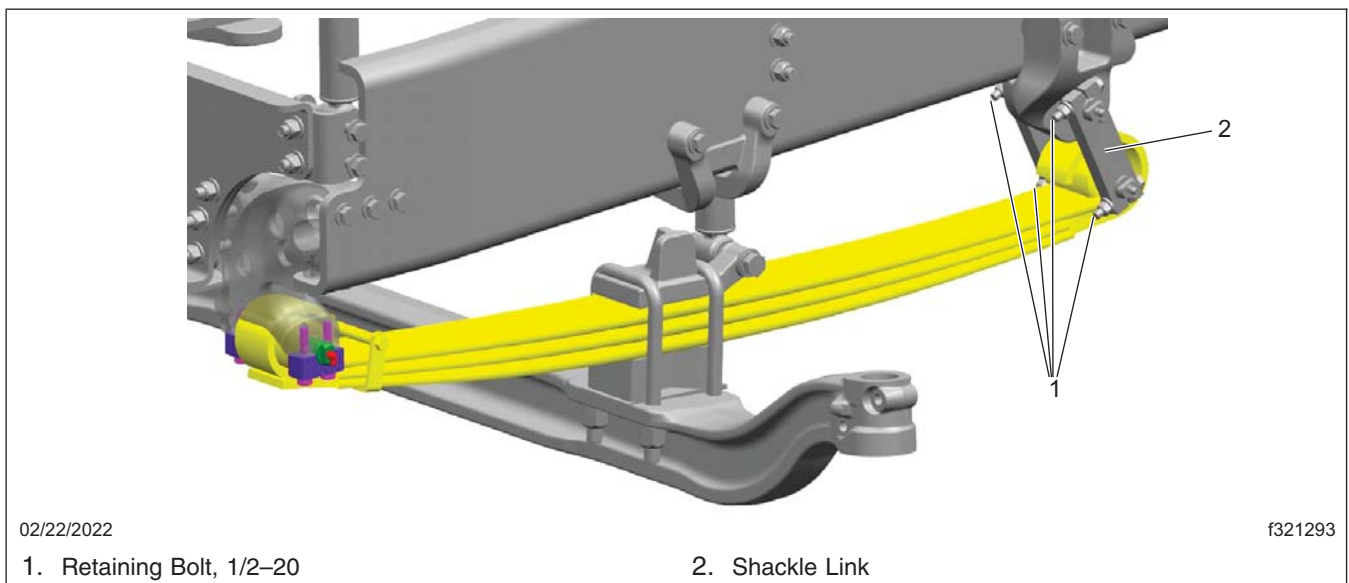

Fig. 1, Front Suspension Setup

March 2022
SF648A

IMPORTANT: The shackle link material can be identified by the shackle link part number. The part number is usually stamped on the side of the shackle link. If the stamped number cannot be identified, use the PartsPro application to identify the shackle link part number under subgroup 620.

- A shackle link with part number ending with -000 is made of aluminum.
 - A shackle link with part number ending with -001 is made of steel.
6. Install the four ½-inch shackle link retaining bolts.
 - **For steel shackle links:** Tighten the shackle link retaining bolts 57 to 69 lbf-ft (77 to 94 N·m).
 - **For aluminum shackle links:** Tighten the shackle link retaining bolts 40 to 48 lbf-ft (54 to 65 N·m).
 7. Repeat steps 5 and 6 on the other side of the vehicle.
 8. Raise the front axle, remove the safety stands from the axle, then lower the axle.
 9. Raise the vehicle, remove the safety stands that were supporting the frame, then lower the vehicle. For instructions to raise and lower the vehicle, see **Group 00** of the *47X and 49X Workshop Manual*.
 10. Clean a spot on the base label (Form WAR259) and attach a campaign completion sticker for SF648 (Form WAR260), indicating this work has been completed.