



Original Publication Date: February 24, 2022

To: All Lexus Dealer Principals, General Managers, Service Managers, Parts Managers, and Warranty Administrators

## SPECIAL SERVICE CAMPAIGN 22LC01

### Multiple 2021 - 2022 Model Year Vehicles DCM (Data Communication Module) Reprogramming

Model / Years	Production Period	Approximate Total Vehicles	
2021 Model Year IS 300	Late May 2021 - Early August 2021	2,200	55,700
2021 Model Year IS 350	Late May 2021 - Late August 2021	3,700	
2021 Model Year LC 500	Late May 2021 - Early August 2021	200	
2021 Model Year LC 500h	Early June 2021 - Late July 2021	4	
2021 Model Year LC 500 Convertible	Late May 2021 - Early August 2021	400	
2021 Model Year LS 500	Late May 2021 - Early August 2021	900	
2021 Model Year LS 500h	Late May 2021 - Late July 2021	20	
2021 Model Year NX 300	Late May 2021 - Mid-August 2021	13,900	
2021 Model Year NX 300h	Late May 2021 - Mid-August 2021	3,000	
2021 Model Year RC 300	Late May 2021 - Late July 2021	300	
2021 Model Year RC 350	Mid-May 2021 - Late July 2021	500	
2021 Model Year RC F	Late May 2021 - Early August 2021	50	
2021 - 2022 Model Year RX 350	Late June 2021 - Mid-October 2021	22,100	
2021 - 2022 Model Year RX 350L	Late May 2021 - Early August 2021	2,300	
2021 - 2022 Model Year RX 450h	Late June 2021 - Early October 2021	5,600	
2021 - 2022 Model Year RX 450hL	Late May 2021 - Early August 2021	600	
2022 Model Year GX 460	Early August 2021	1	

#### Condition

Due to improper programming of the Data Communication Module (DCM), which provides cellular communication in various situations, including emergencies, the driver and Safety Connect operator may not be able to hear each other's voices during a Safety Connect call.

#### Remedy

Any authorized Lexus dealer will update the DCM software **FREE OF CHARGE**.

#### Covered Vehicles

There are approximately 55,700 vehicles covered by this Special Service Campaign. Approximately 200 vehicles involved in this Special Service Campaign were distributed to Puerto Rico.

#### Owner Letter Mailing Date

Lexus will begin to notify owners in late-March 2022. A sample of the owner notification letter has been included for your reference.

*Lexus makes significant effort to obtain current customer name and address information from each state through industry resources when mailing owner letters. In the event your dealership receives a notice for a vehicle that was sold prior to the Special Service Campaign announcement, it is the dealership's responsibility to forward the owner letter to the customer who purchased the vehicle.*

Please note that only owners of the covered vehicles will be notified. If you are contacted by an owner who has not yet received a notification, please **verify eligibility by confirming through TIS prior to performing repairs**. Dealers should perform the repair as outlined in the Technical Instructions found on TIS.

## Dealer Inventory Procedures

### New and Used Vehicles in Dealership Inventory (In-Stock Vehicles)

To ensure customer satisfaction, Lexus requests that dealers complete this Special Service Campaign on any new or used vehicles currently in dealer inventory that are covered by this Special Service Campaign prior to customer delivery. However, if the campaign cannot be completed (for example, due to remedy parts availability), delivery of a covered vehicle is acceptable if disclosed to the customer that the vehicle is involved in a Special Service Campaign.

Lexus expects dealers to use the attached Customer Contact and Vehicle Disclosure Form to obtain vehicle buyer information. Dealers are expected to provide a copy of the completed form, along with the most current FAQ, to the vehicle buyer. Lexus and the dealer may use this information to contact the customer when the remedy becomes available.

Keep the completed form on file at the dealership and send a copy to [quality\\_compliance@toyota.com](mailto:quality_compliance@toyota.com). In the subject line of the email state, "Disclosure Form 22LC01" and include the VIN.

**NOTE:** Dealers can identify if any of their new and used inventory has any open campaigns in the Vehicle Inventory Summary available in Dealer Daily (<https://dealerdaily.lexus.com/>). The Vehicle Inventory Summary may take up to 4 hours to populate information for newly launched campaigns.

### L/Certified Vehicles

L/Certified policy prohibits the certification of any vehicle with an outstanding Safety Recall, Special Service Campaign, or Limited Service Campaign. Thus, no affected units are to be designated, sold, or delivered as an L/Certified vehicle until all applicable Safety Recalls, Special Service Campaigns, and Limited Service Campaigns have been completed on that vehicle.

## Customer Handling, Parts Ordering, and Remedy Procedures

### Customer Contacts

Customers who receive the owner letter may contact your dealership with questions regarding the letter and/or the Special Service Campaign. Please welcome them to your dealership and answer any questions that they may have. A Q&A is provided to assure a consistent message is communicated.

Customers with additional questions or concerns are asked to please contact the Lexus Brand Engagement Center at 1-800-255-3987 Monday through Friday, 8:00 am to 8:00 pm, Saturday 9:00 am to 7:00 pm Eastern Time.

### Head Unit Notifications

Head unit notifications are electronic messages that are displayed in the vehicle's audio system screen. Customers who receive head unit notification regarding this Special Service Campaign are requested to schedule an appointment with their authorized dealer to have this Special Service Campaign completed.

When these messages are received by the vehicle's Data Communication Module, the head unit will display a pop-up prompt stating that the vehicle has a new Special Service Campaign. The prompt will contain options to 'Remind Me' or to 'View' the message. If a customer chooses 'Remind Me', the customer can then choose to be reminded again on next trip, in 7 days, or in 30 days. If a customer views and then closes the message, the message will be available in the Notification App if the customer chooses to review it again. If the vehicle's completion status remains incomplete for a period of 90 days from the message being viewed, the head unit may display a renotification pop-up prompt as an additional reminder to the customer to have this Special Service Campaign completed.

The message will completely clear from the vehicle once the following conditions are met: The Special Service Campaign is completed, the dealer has filed a claim, and the claim is approved by Lexus. Then the message will be cleared at the next clearing cycle, which currently happens daily.

Owners who receive a head unit notification after having this Special Service Campaign completed can be advised to ignore the message. Owners with additional concerns can be directed to the Lexus Brand Engagement Center at 1-800-255-3987 Monday through Friday, 8:00 am to 8:00 pm, Saturday 9:00 am to 7:00 pm Eastern Time.

**Salvage Title Vehicles**

Every attempt should be made to complete an open Special Service Campaign when circumstances permit, unless noted otherwise in the SSC dealer letter.

For complete details on this policy, refer to Lexus Warranty Policy [4.15](#), "What Is Not Covered by the Lexus New Vehicle Limited Warranty".

**Media Contacts**

It is imperative that all media contacts (local and national) receive a consistent message. In this regard, all media contacts must be directed to Aaron Fowles (469) 292-1097 in Toyota Corporate Communications. Please do not provide this number to customers. Please provide this contact only to media.

**Technician Training Requirements**

The repair quality of covered vehicles is extremely important to Lexus. All dealership technicians performing this repair are required to successfully complete the most current version of the E-Learning course "Safety Recall and Service Campaign Essentials". To ensure that all vehicles have the repair performed correctly; technicians performing this repair are required to currently have completed all of the following courses:

- L623 - Lexus Electrical Circuit Diagnosis

Always check which technicians can perform the repair by logging on to <https://www.lctpreports.com>. It is the dealership's responsibility to select technicians with the above certification level or greater to perform this repair. Carefully review your resources, the technician skill level, and ability before assigning technicians to this repair. It is important to consider technician days off and vacation schedules to ensure there are properly trained technicians available to perform this repair at all times.

**Remedy Procedures**

Refer to TIS for Technical Instructions on repair. Conduct all non-completed Safety Recalls and Service Campaigns on the vehicle during the time of appointment.

**Repair Quality Confirmation**

The repair quality of covered vehicles is extremely important to Lexus. To help ensure that all vehicles have the repair performed correctly, please designate at least one associate (someone other than the individual who performed the repair) to verify the repair quality of every vehicle prior to customer delivery.

## Warranty Reimbursement Procedures

### Warranty Reimbursement Procedure

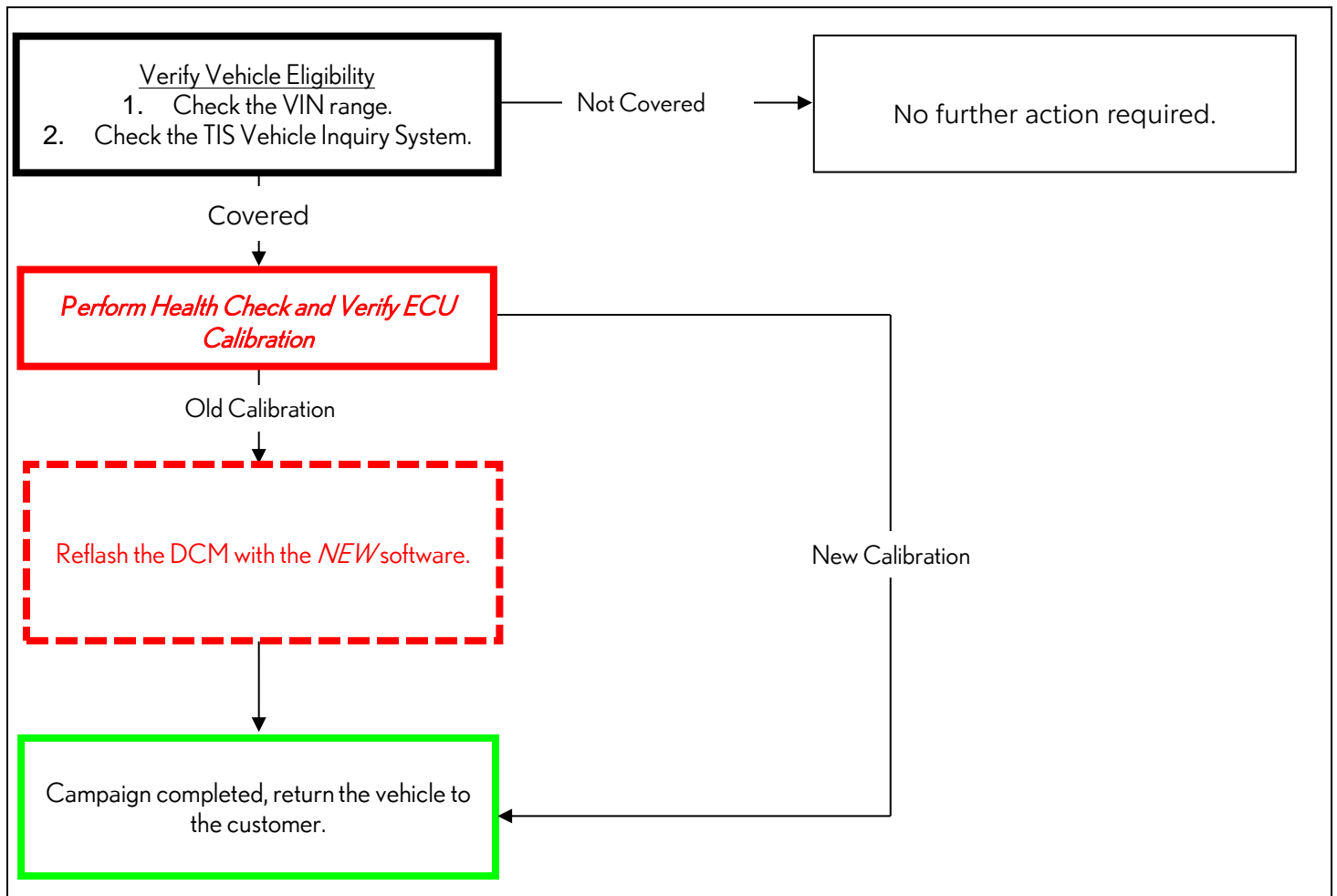

Op Code	Description	Flat Rate Hours
TEC009	Reprogram the DCM	0.7

- The flat rate times include 0.1 hours for administrative cost per unit for the dealership.
- In the rare case that Telematics ECU (DCM) contains the latest calibration ID (no software update needed), use opcode TEC009.

Lexus' usual customer care amenities of car wash and fuel fill-up apply to this Special Service Campaign. Additionally, a maximum of one day of rental vehicle expense (at a maximum rate of \$55.00 per day) while the vehicle is being remedied or the cost of pick-up and redelivery of the customer's car may be claimed if required and subject to the guidelines published in the Safety Recall and Special Service Campaign General Procedures document on TIS.

#### Claim Filing Accuracy and Correction Requests

It is the dealer's responsibility to file claims correctly for this Special Service Campaign. This claim filing information is used by Lexus for various government reporting activities; therefore, claim filing accuracy is crucial. If it has been identified that a claim has been filed using an incorrect Op Code or a claim has been filed for an incorrect VIN, refer to Warranty Procedure Bulletin [PRO17-03](#) to correct the claim.

## Campaign Designation / Phase Decoder

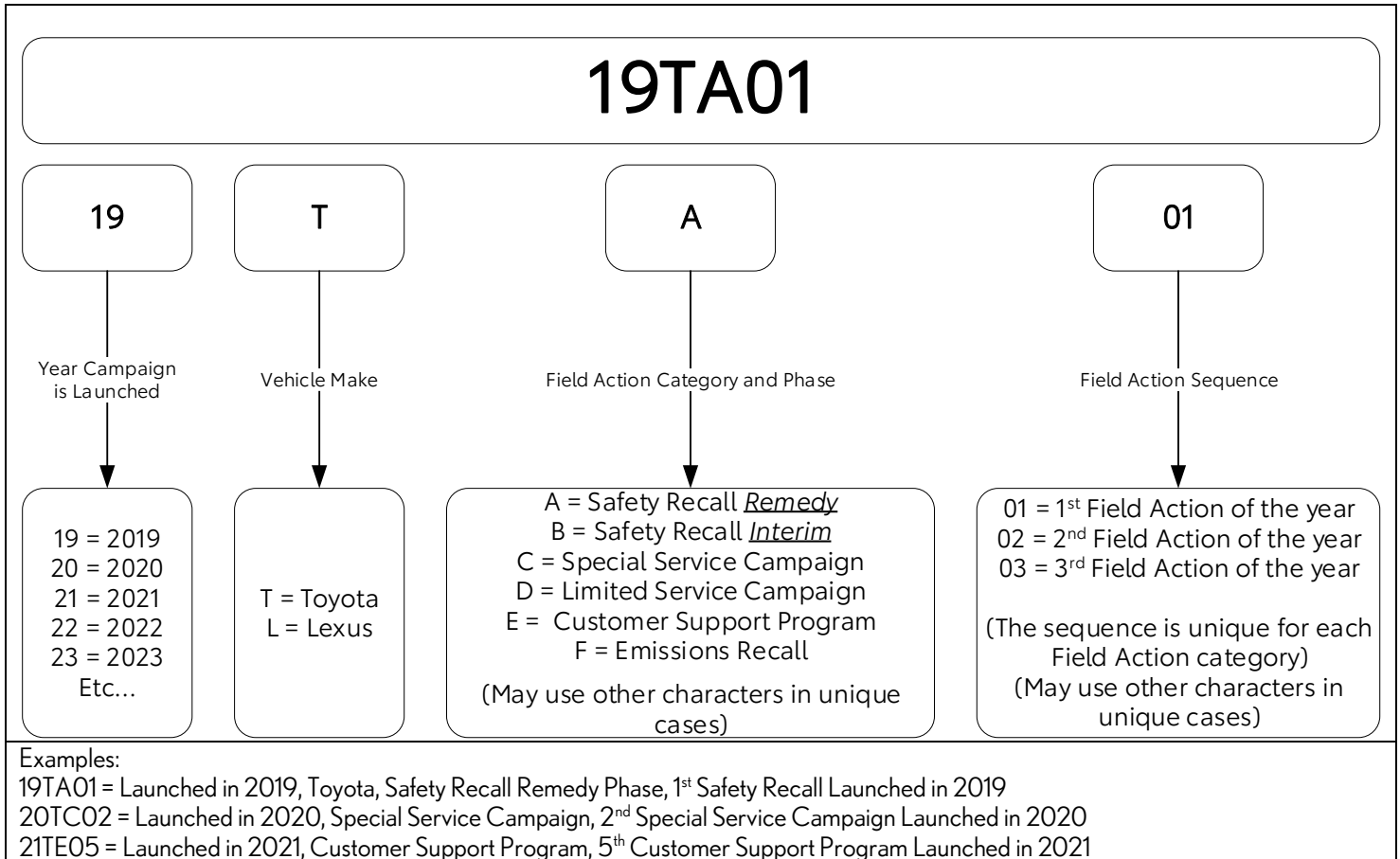

*Please review this entire package with your Service and Parts staff to familiarize them with the proper step-by-step procedures required to implement this Special Service Campaign.*

Thank you for your cooperation.

LEXUS, A DIVISION OF TOYOTA MOTOR SALES, U.S.A., INC.



## SPECIAL SERVICE CAMPAIGN 22LC01

Multiple 2021 - 2022 Model Year Vehicles  
DCM (Data Communication Module) Reprogramming

Frequently Asked Questions  
Original Publication Date: February 24, 2022

**Q1:** *What is the condition?*

A1: Due to improper programming of the Data Communication Module (DCM), which provides cellular communication in various situations, including emergencies, the driver and Safety Connect operator may not be able to hear each other's voices during a Safety Connect call.

**Q1a:** *Are there any warnings that this condition exists?*

A1a: No, there are no advanced warnings prior to the occurrence of this condition.

**Q1b:** *Can I avoid the condition before a repair is made?*

A1b: Yes. This condition may occur when the ignition is turned off and then turned back again on within approximately 5-6 seconds. In order to avoid this condition, wait at least 6 seconds before turning the ignition back on after turning it off.

**Q1c:** *If this condition occurs, is it permanent?*

A1c: No, the condition is only present during the ignition cycle in which the error occurred. If you believe you may have turned the ignition on within 5-6 seconds of turning it off, you may turn the ignition off and follow the steps in A1b above to restore functionality to the Safety Connect system.

**Q2:** *What is Lexus going to do?*

A2: Lexus will send an owner notification by first class mail starting in late-March 2022, advising owners to make an appointment with their authorized Lexus dealer to have the DCM software updated **FREE OF CHARGE**.

**Q3: Which and how many vehicles are covered by this Special Service Campaign?**

A3: There are approximately 55,700 vehicles covered by this Special Service Campaign.

Model / Years	Production Period	Approximate Total Vehicles	
2021 Model Year IS 300	Late May 2021 – Early August 2021	2,200	55,700
2021 Model Year IS 350	Late May 2021 – Late August 2021	3,700	
2021 Model Year LC 500	Late May 2021 – Early August 2021	200	
2021 Model Year LC 500h	Early June 2021 – Late July 2021	4	
2021 Model Year LC 500 Convertible	Late May 2021 – Early August 2021	400	
2021 Model Year LS 500	Late May 2021 – Early August 2021	900	
2021 Model Year LS 500h	Late May 2021 – Late July 2021	20	
2021 Model Year NX 300	Late May 2021 – Mid-August 2021	13,900	
2021 Model Year NX 300h	Late May 2021 – Mid-August 2021	3,000	
2021 Model Year RC 300	Late May 2021 – Late July 2021	300	
2021 Model Year RC 350	Mid-May 2021 – Late July 2021	500	
2021 Model Year RC F	Late May 2021 – Early August 2021	50	
2021 – 2022 Model Year RX 350	Late June 2021 – Mid-October 2021	22,100	
2021 – 2022 Model Year RX 350L	Late May 2021 – Early August 2021	2,300	
2021 – 2022 Model Year RX 450h	Late June 2021 – Early October 2021	5,600	
2021 – 2022 Model Year RX 450hL	Late May 2021 – Early August 2021	600	
2022 Model Year GX 460	Early August 2021	1	

**Q3a: Are there any other Lexus/Toyota/Scion vehicles covered by this Special Service Campaign in the U.S.?**

A3a: Yes, there are approximately 221,700 Toyota vehicles covered by Special Service Campaign 22TC01. The following vehicles are covered:

Model / Years	Production Period	Approximate Total Vehicles	
2021 – 2022 Model Year 4Runner	Late May 2021 – Early August 2021	32,000	221,700
2021 Model Year C-HR	Early June 2021 – Late November 2021	4,200	
2021 – 2022 Model Year Highlander	Late June 2021 – Late October 2021	52,100	
2021 – 2022 Model Year Highlander HV	Late June 2021 – Mid-October 2021	18,600	
2022 Model Year Prius	Early June 2021 – Mid-August 2021	5,600	
2021 – 2022 Model Year Prius Prime	Late May 2021 – Mid-August 2021	800	
2021 Model Year RAV4 Prime	Late May 2021 – Late July 2021	8,800	
2021 – 2022 Model Year Sequoia	Late June 2021 – Late October 2021	1,800	
2021 – 2022 Model Year Tacoma	Late June 2021 – Mid-November 2021	66,500	
2021 Model Year Tundra	Late June 2021 – Mid-October 2021	31,300	

**Q4: How long will the repair take?**

A4: The repair takes approximately 45 minutes. However, depending upon the dealer's work schedule, it may be necessary to make the vehicle available for a longer period of time.

**Q5: How does Lexus obtain my mailing information?**

A5: Lexus uses an industry provider who works with each state's Department of Motor Vehicles (DMV) to receive registration or title information, based upon the DMV records. Please make sure your registration or title information is correct.

**Q6:** *What if I have additional questions or concerns?*

A6: If you have additional questions or concerns, please contact the Lexus Brand Engagement Center at 1-800-255-3987 Monday through Friday, 8:00 am to 8:00 pm, Saturday 9:00 am to 7:00 pm Eastern Time.





Lexus, A Division of Toyota Motor Sales, USA, Inc.  
6565 Headquarters Drive  
Plano, TX 75024  
(469) 292-4000

## CUSTOMER CONTACT & VEHICLE DISCLOSURE FORM

This form is not applicable for L/Certified units.

This vehicle is involved in a Special Service Campaign. At this time, remedy parts are not available, and the remedy has **NOT** been performed. I understand that the vehicle will need to be returned to an authorized Lexus dealer to have the remedy performed at **NO CHARGE** when the remedy is available.

Customer Signature \_\_\_\_\_

Lexus recommends that you register with the Lexus Owners Community at <http://www.lexus.com/drivers/> and regularly check recall applicability using [www.lexus.com/recall](http://www.lexus.com/recall) or [www.safercar.gov](http://www.safercar.gov). You will need to input your 17-digit Vehicle Identification Number (VIN).

VIN

Campaign Code

Model \_\_\_\_\_ Model Year \_\_\_\_\_

### Customer Information

Customer Name \_\_\_\_\_ Customer Email \_\_\_\_\_

Customer Address \_\_\_\_\_ Home Phone # \_\_\_\_\_

\_\_\_\_\_ Mobile Phone # \_\_\_\_\_

\_\_\_\_\_ Date \_\_\_\_\_

*Please provide this information so that Lexus or your dealer can notify you when the remedy becomes available. This information will only be used for campaign communications. If you'd like to update your preferred contact information in the future, visit [www.lexus.com/ownersupdate](http://www.lexus.com/ownersupdate) or contact us at 1-800-255-3987.*

### Dealer Information

Dealer Name/Address \_\_\_\_\_ Dealer Code \_\_\_\_\_

\_\_\_\_\_ Dealer Phone Number \_\_\_\_\_

\_\_\_\_\_ Dealer Staff Name \_\_\_\_\_

\_\_\_\_\_ Dealer Staff Signature \_\_\_\_\_



Multiple 2021 - 2022 Model Year Vehicles  
DCM (Data Communication Module) Reprogramming  
Special Service Campaign 22LC01

[VIN]

Dear Lexus Customer:

At Lexus, we are dedicated to providing vehicles of outstanding quality and value. As part of our continuing efforts to provide superior customer satisfaction, Lexus is announcing a Special Service Campaign, which includes your vehicle.

You received this notice because our records, which are based primarily on state registration and title data, indicate that you are the current owner.

**What is the condition?**

Due to improper programming of the Data Communication Module (DCM), which provides cellular communication in various situations, including emergencies, the driver and Safety Connect operator may not be able to hear each other's voices during a Safety Connect call.

**What will Lexus do?**

Any authorized Lexus dealer will update the DCM software **FREE OF CHARGE** to you.

**What should you do?**

Before you are inconvenienced by this condition, any authorized Lexus dealer will perform the software update **FREE OF CHARGE** to you.

Please contact your authorized Lexus dealer to make an appointment to have the software update performed. The remedy will take approximately 45 minutes. However, depending on the dealer's work schedule, it may be necessary to make your vehicle available for a longer period of time.

**NOTE:**

This condition may occur when the ignition is turned off and then turned back again on within approximately 5-6 seconds. In order to avoid this condition until your vehicle's software has been updated, wait at least 6 seconds before turning the ignition back on after turning it off. If you believe you may have turned the ignition on within 5-6 seconds of turning it off, turn the ignition off again and wait at least 6 seconds before turning it back on to restore functionality to the Safety Connect system.

What if you have other questions?

- *Your local Lexus dealer will be more than happy to answer any of your questions.*
- For more information on this and other campaigns, please visit [www.lexus.com/recall](http://www.lexus.com/recall).
- ✓ If you require further assistance, you may contact the Lexus Brand Engagement Center at 1-800-255-3987 Monday through Friday, 8:00 am to 8:00 pm, Saturday 9:00 am to 7:00 pm Eastern Time.

If you would like to update your vehicle ownership or contact information, please visit <https://www.toyota.com/recall/update-info-lexus>. You will need your full 17-digit Vehicle Identification Number (VIN) to input the new information.

If you are a vehicle lessor, please assist us by forwarding this notice to the lessee.

We have sent this notice in the interest of your continued satisfaction with our products, and we sincerely regret any inconvenience this condition may have caused you.

Thank you for driving a Lexus.

Sincerely,

LEXUS, A DIVISION OF TOYOTA MOTOR SALES, U.S.A., INC.

SAMPLE