



INSTRUCTION TO SERVICE

ITS: 60312		NOV/5/2021
SECTION:	260-BATTERY COMPARTMENT	
WRITTEN BY:	Ilan Kizner	
SUBJECT:	Rework – High voltage receptacle assembly.	
ISSUE:	Failing DC Contactors	
SUMMARY:	Issue identified as low-quality crimping of lugs on the receptacle side	

ITS60312

THIS ITS DOCUMENT SHOULD BE RETAINED AND REFERRED TO FOR FUTURE MAINTENANCE UNTIL THE NEW FLYER PARTS AND/OR SERVICE MANUAL IS UPDATED TO REFLECT WORK DONE AS A RESULT OF THIS DOCUMENT. ENSURE THAT THIS DOCUMENT IS AVAILABLE FOR PARTS AND MAINTENANCE STAFF GOING FORWARD.



Contents

INSTRUCTION TO SERVICE	1
1. SAFETY PROCEDURE	3
2. Rework Procedure - remove curb side receptacle assembly:	4
3. Rework Procedure - remove street side receptacle assembly	6
Appendix A – Receptacle assembly rework procedure.....	9
Appendix B - Inspection and temperature follow-up table.....	12
Appendix C - Tools and labor	13



NEW FLYER

⚠ WARNING: Only trained personnel shall supervise and perform High Voltage system testing, checkout and troubleshooting. Two personnel (one called the Checker & the other called Monitor/Recorder) shall perform Checkout Procedures, together, to ensure safety of themselves, others nearby & for the protection of vehicle & property. Refresher training shall be provided to these personnel on a regular basis and when new systems are to be checked by them. The training of the personnel shall consist of:

1. SAFETY PROCEDURE

- 1.1. Turn the master run switch to the off position and wait 5 minutes before proceeding.
- 1.2. Turn the 12/24V battery disconnect and HV Interlock switch to the "OFF" position.
- 1.3. Lock and Tag the electrical system of the bus out and retain the key. See Figure 1.
- 1.4. Install a Lockout/Tagout Steering wheel cover as require

- ☞ **NOTE:** Refer to the Lockout/Tagout Procedure in section 1 of your Preventive Maintenance Manual or section 9 of your Service manual for additional information.
- ☞ **NOTE:** Use commercially available lock out equipment and tags being sure to follow any local laws or workplace procedures.
- ☞ **NOTE:** Refer to New Flyer High Voltage Safety Guidelines and Procedures Document 532295 (**Appendix A**) when completing installation or service work on high voltage power cables.

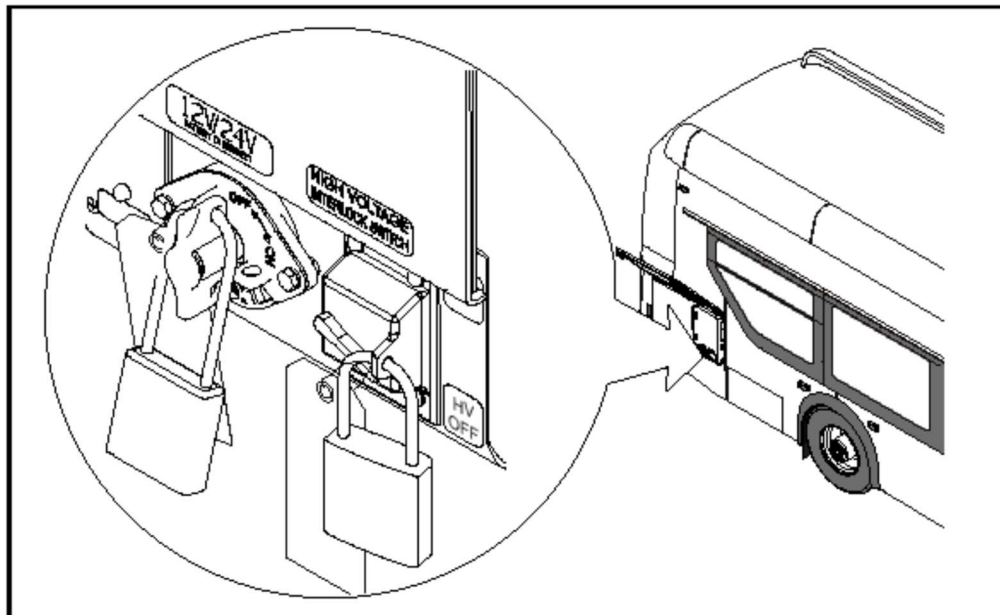

Figure 1: Lockout tagout location reference



NEW FLYER®

2. Rework Procedure - remove curb side receptacle assembly:

2.1. Locate receptacle assembly behind CS fuse box access door.

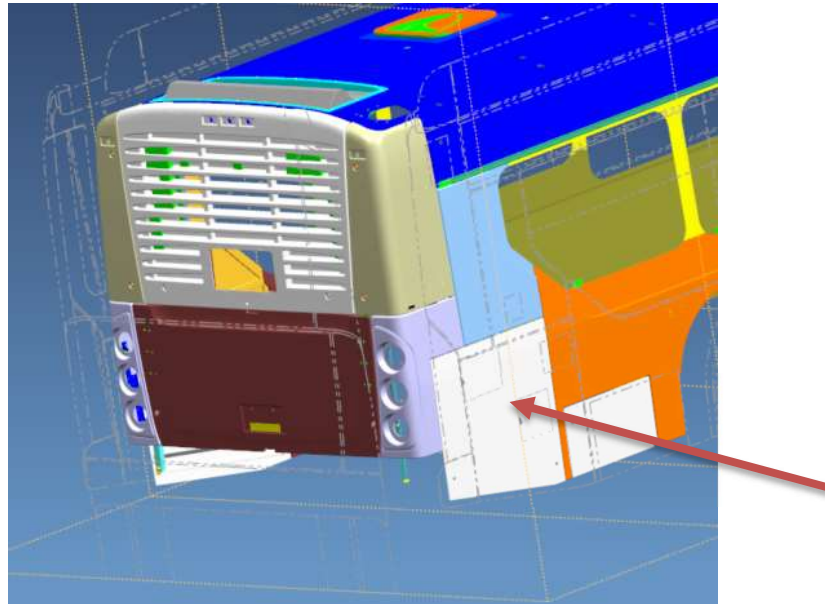

2.2. Open charge box cover by removing 4 screws and washers

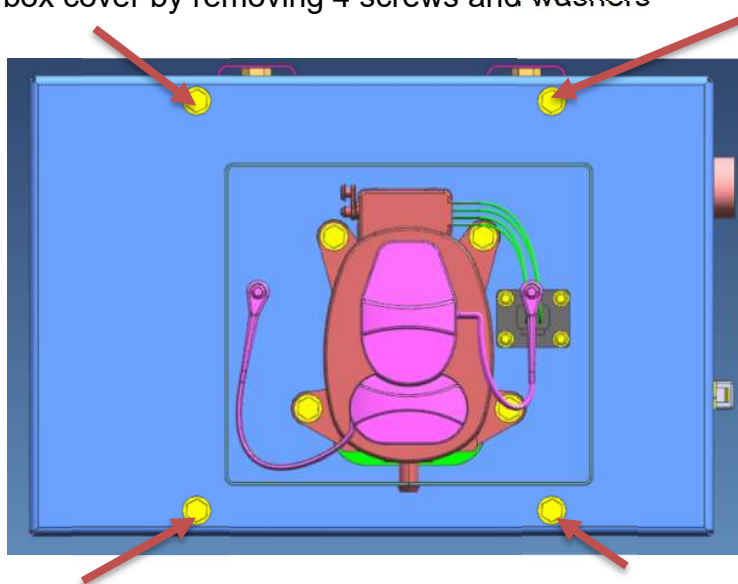



NEW FLYER

2.3. Disconnect the two positive and negative HV cables from the DC contactors, ground cable and signals plug and remove front cover plate and receptacle.

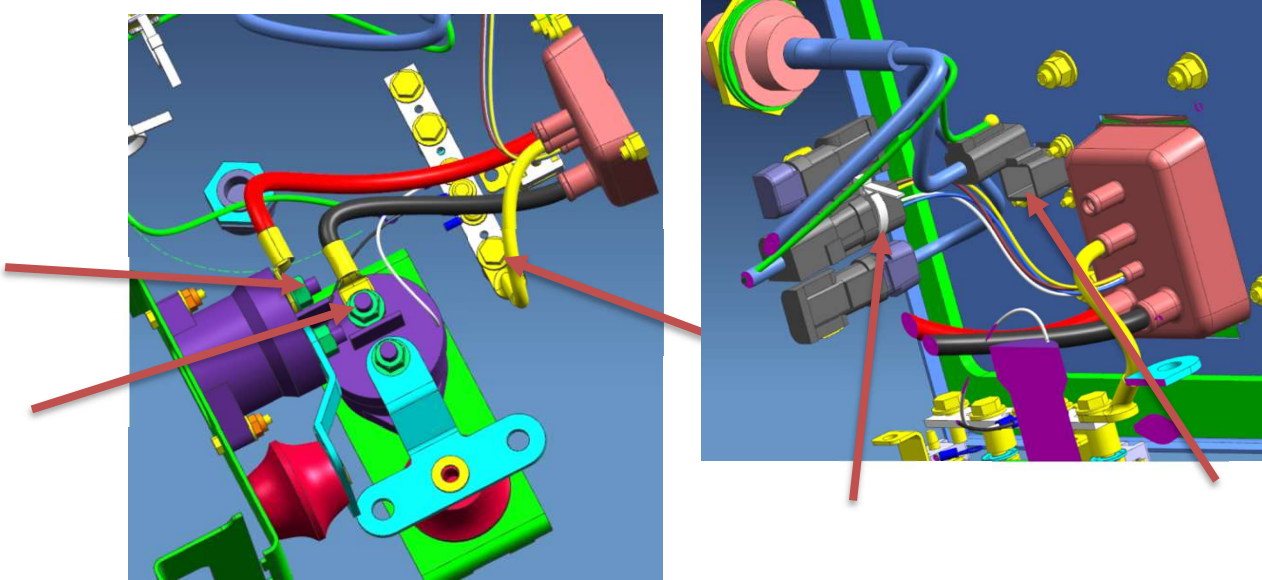

2.4. Detach receptacle assembly from front cover plate by removing the following 4 screws

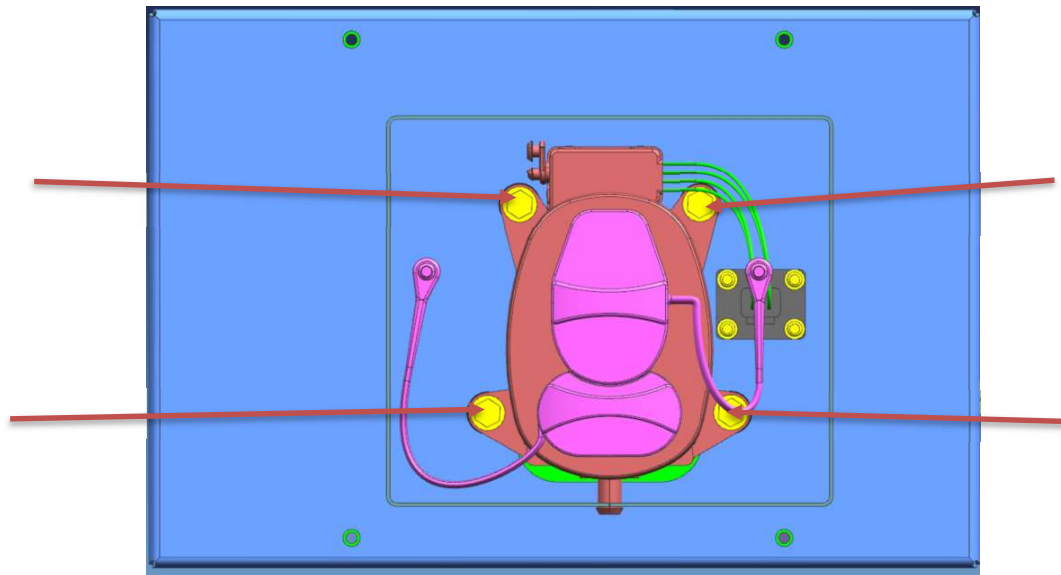

2.5. Refer to install 764167 for additional information.

2.6. Refer to Appendix A on how to rework the receptacle assembly.



NEW FLYER

3. Rework Procedure - remove street side receptacle assembly

3.1. Locate the receptacle assembly behind heater access door.

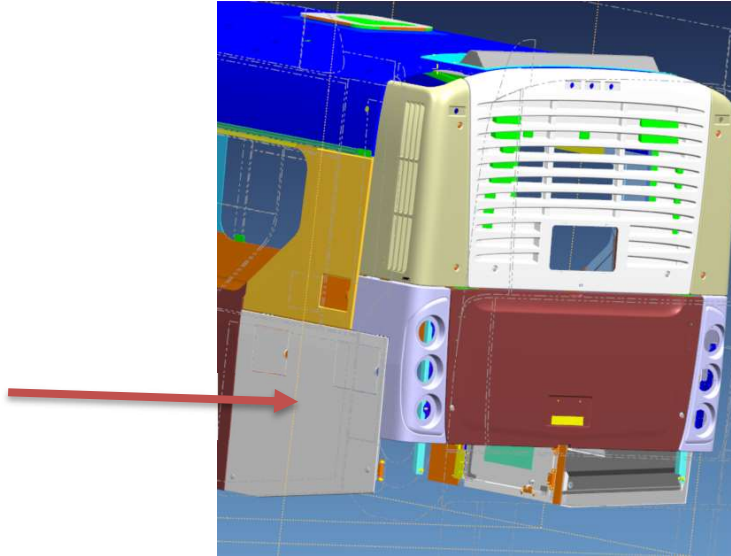

3.2. On the receptacle box remove 4 front cover plate screws.

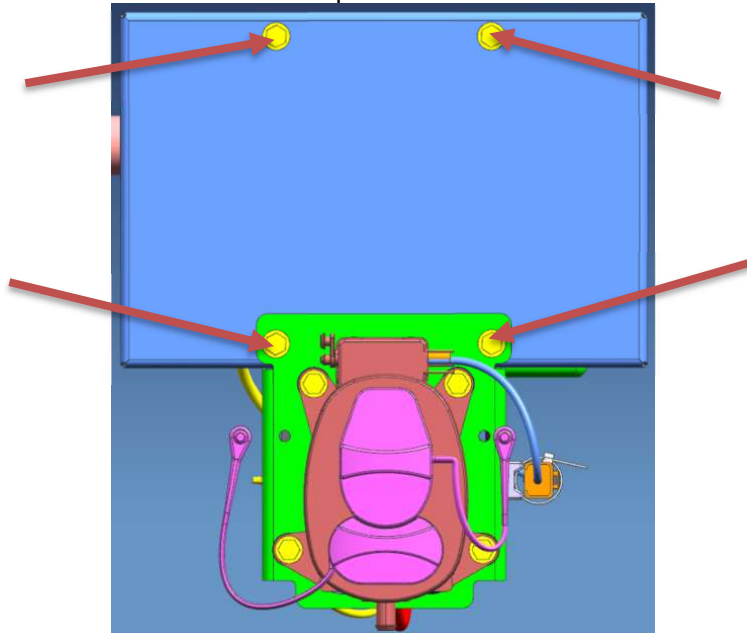



NEW FLYER

3.3. Disconnect the positive and negative HV cables from the contactors

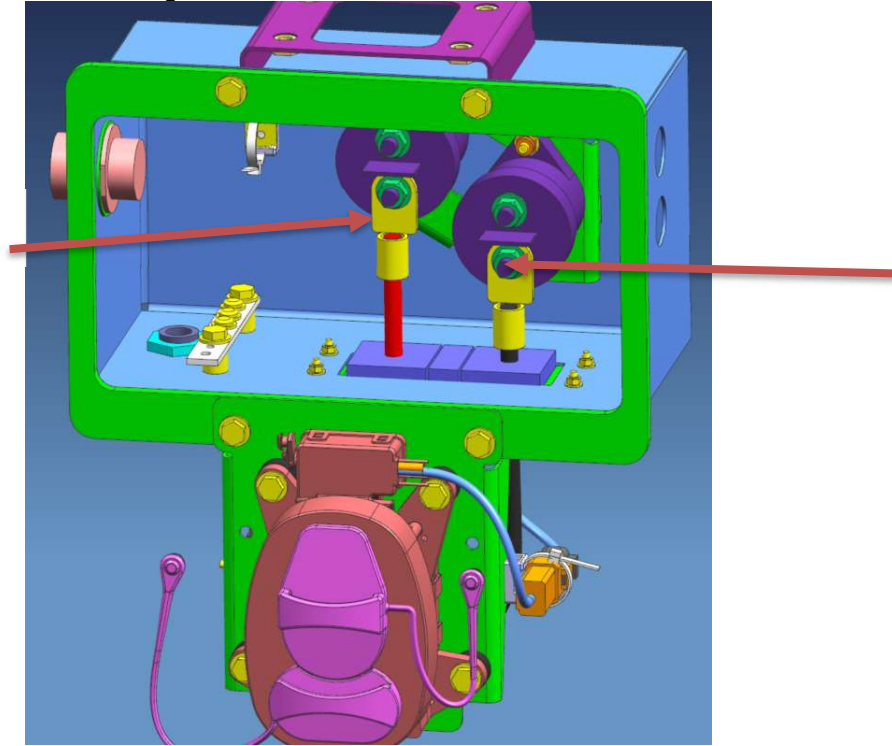

3.4. Disconnect ground wire from bottom of the receptacle box and the two signal plugs RECEPT1 and RECEPT2

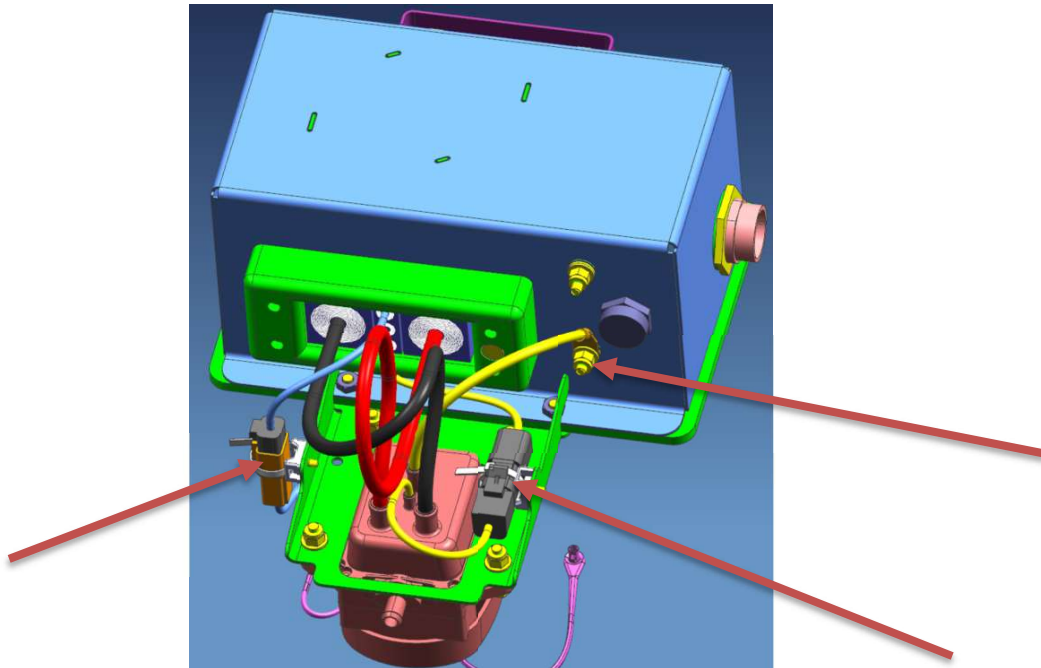



NEW FLYER

3.5. Detach receptacle from box assembly by removing the following 4 screws:

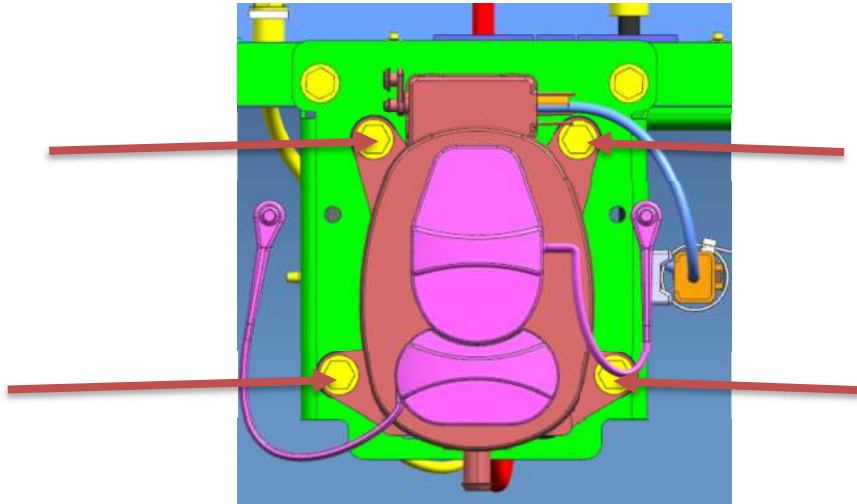

3.6. Refer to install 751729 for additional information.

3.7. Refer to Appendix A on how to rework the receptacle assembly.

3.8. After the rework is done apply thermal strips on each of the HV cable ring terminals heatshrink as shown below:

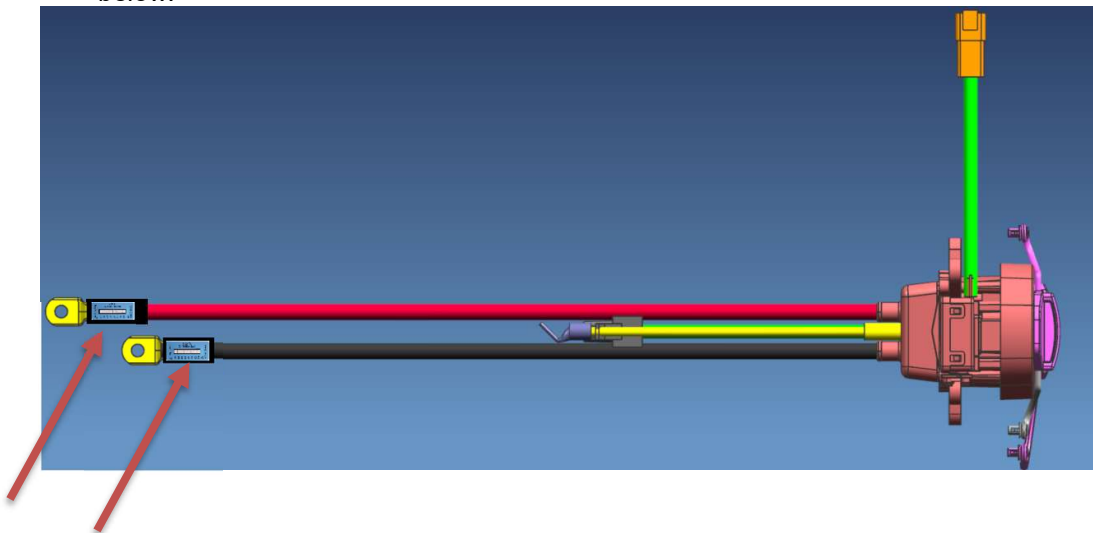

3.9. Use the Inspection and temperature follow-up table in Appendix B to record the temperatures on the ring terminals.

Appendix A – Receptacle assembly rework procedure.

**** Note: the following rework applies to both positive and negative receptacle assemblies HV cables (674318 and 752163). The maximum length that can be cut from the existing cable should not exceed 3" inches in total.**

1. Remove heat shrink from the HV positive and negative ring terminals cables.
2. Cut existing ring terminal using cable cutter 6490350.
3. Remove outer insulation jacket and shield 5" back from cable using cable splitter 6490351.
4. Use heat shrink NFI part number 136365 to cover outer insulation and exposed shield extending to the HV cable.
5. Strip 1" inch of the exposed cable and visually inspect for signs of heat damage and discoloration. Any damaged cable strands should be removed.
6. Use crimping tool 6490348 to crimp ring terminal 640366 on striped wire.

****Note: For ring terminal 640366, strip length should be 1" inch.**

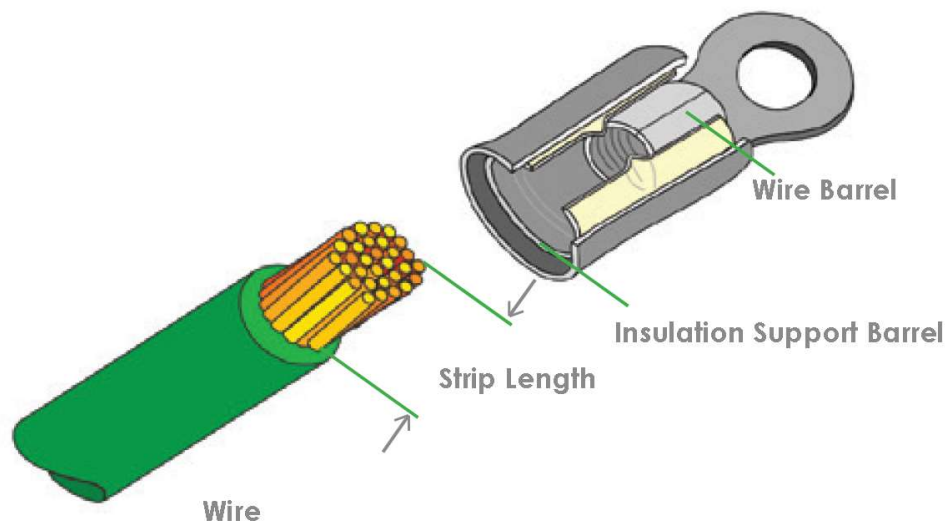

7. Install the terminal lug on the end of the cable, ensuring no copper strands extrude past the end of the barrel.
8. Ensure wire strands are visible at the ring terminal inspection window.

9. Open the crimping tool upper cover by pressing the release lever (1).

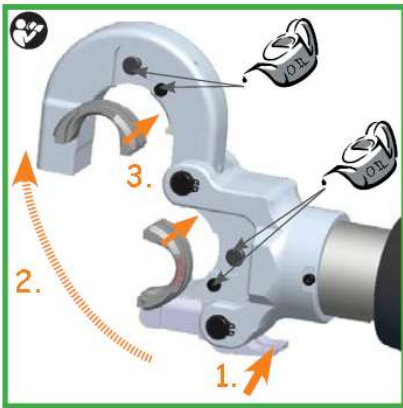

10. Install Panduit Hex Die adapter set (3). You should hear a click sound when the die are secured in place.

11. Attach the Panduit CD-2001 (NF P/N 6490349) Die set on top of existing Dies.



12. Insert cable with ring terminal into the die and close upper cover.

13. Latch the top cover in place with a clicking sound.



****Note: For the following ring terminal and cable a double crimp should be applied. Crimp should be in order 1, 2 as shown in the pictures below:**

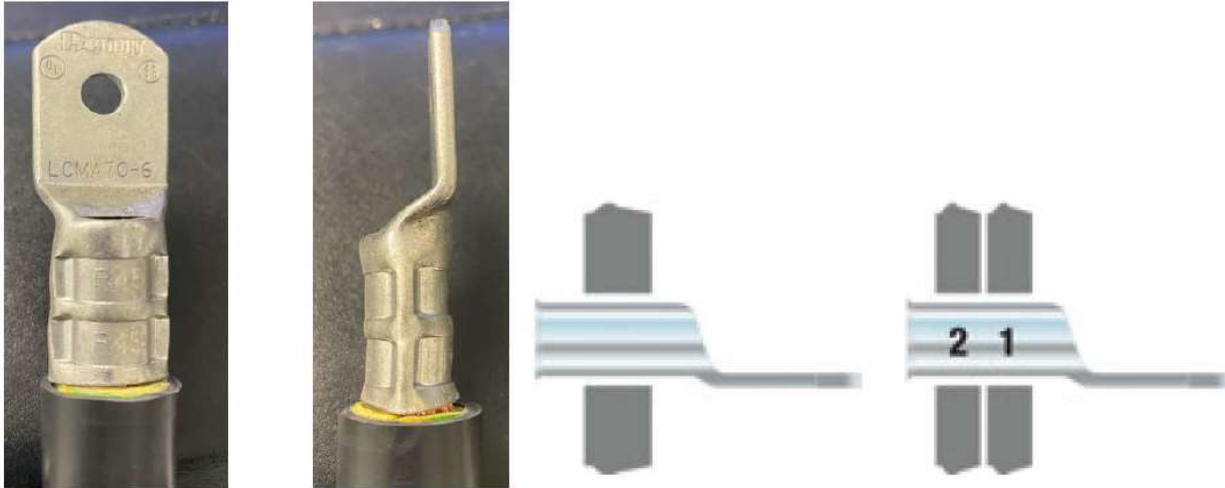

14. Align the ring terminal on location 1 and press the trigger to start crimping. The head will release itself when crimping is complete. After the crimping is complete, release the trigger.



15. After the first crimp is done press the release button to release the cable, align the ring terminal to position 2 and repeat the crimping operation again. If for some reason the crimp process is stopped then use the upper trigger to release the crimp head.

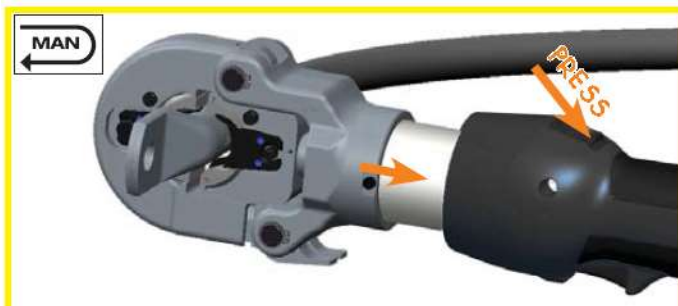



NEW FLYER

Appendix B - Inspection and temperature follow-up table

Bus Number: _____

Reading number	Date	Charge Current	Initial SOC	Temperature
1				
2				
3				
4				
5				
6				
7				
8				
9				
10				

Bus Number: _____

Reading number	Date	Charge Current	Initial SOC	Temperature
1				
2				
3				
4				
5				
6				
7				
8				
9				
10				

Bus Number: _____

Reading number	Date	Charge Current	Initial SOC	Temperature
1				
2				
3				
4				
5				
6				
7				
8				
9				
10				

1. Please record the temperature stripe reading in the above table.
2. each test should be performed while charging at 200Amps



Appendix C - Tools and labor

LABOUR ESTIMATE				
	Operation	Number of Technician(s)	Hours	Labor Time T X HR
	Rework receptacle assembly (one side)	1	2.0	2.0

PARTS REQUIRED					
Item	Part Number	Description	Qty. per Coach	Units	Notes
1	136365	TUBE-HEAT SHRINK .75 SS	1	FT	
2	640366	TERM-R M8 70MMSQ NIN	4	EA	

SPECIAL TOOLS REQUIRED					
Item	Part Number	Description	Qty. per Coach	Units	Notes
1	6490348	TOOL CRIMPING PANDUIT BLACKFIN	1	EA	
2	6490349	TOOL CRIMP DIES PANDUIT	1	EA	
3	6490350	TOOL-NA CABLE CUTTING	1	EA	
4	6490351	TOOL CABLE SLITTER 6 1/2 IN	1	EA	