



# SUBARU®

---

## GENUINE ACCESSORIES

### Remote Engine Start Systems

### Troubleshooting Guide

Applicable to 2017MY+ Impreza, 2018MY+ Crosstrek, 2019MY+ Ascent, 2019MY+ Forester, 2020MY+ Legacy/Outback and 2022MY+ WRX with “Key Start” Ignition

#### !!IMPORTANT!

- Test and diagnose any vehicle diagnostic trouble codes (DTC) prior to proceeding with any Remote Engine Start (RES) part replacements.
- Ensure the vehicle has a fully-charged battery before proceeding, approximately 12.63 volts.
- Ensure that all RES harness connectors are securely seated per the respective installation instructions.
- Ensure the vehicle has a sufficient amount of fuel.
- This guide references back to the respective system’s installation instructions, please have a copy of the installation instructions on hand during troubleshooting.



*“This Troubleshooting Guide is intended for use by professional technicians ONLY. It is written to inform those technicians of conditions that may occur in some vehicles, or to provide information that could assist in the proper servicing of the vehicle. Properly trained technicians have the equipment, tools, safety instructions, and know-how to do the job correctly and safely. If a condition is described in this guide, DO NOT assume that your vehicle will have that condition.”*

## Table of Contents

Service Part Matrix and Graphic Detail – 17–18MY Impreza/18MY Crosstrek .....	3
Service Part Matrix and Graphic Detail – 19MY+ Impreza/Crosstrek .....	4
Service Part Matrix and Graphic Detail – 19MY+ Ascent.....	5
Service Part Matrix and Graphic Detail – 19MY+ Forester.....	6
Service Part Matrix and Graphic Detail – 20MY+ Legacy/Outback .....	7
Service Part Matrix and Graphic Detail – 22MY+ WRX .....	8
System Layout – 17–18MY Impreza / 18MY Crosstrek .....	9
System Layout – 19MY+ Impreza / 19MY+ Crosstrek.....	11
System Layout – 19MY+ Ascent, 19MY+ Forester.....	13
System Layout – 20MY+ Legacy / 20MY+ Outback.....	15
System Layout – 22MY+ WRX.....	17
Remote Engine Start Control Module Registration Procedure – SSM IV (DST–i) 17MY+ Impreza, 18MY+ Crosstrek, 19MY+ Ascent and 19–21MY Forester.....	19
Remote Engine Start Control Module Registration Procedure – SSM IV (DST–i) 20MY+ Legacy / Outback, 22MY+ Forester, 22MY+ WRX .....	20
Remote Engine Start Bi–directional Transmitter Programming Procedure .....	22
Remote Engine Start Run Time Selection.....	22
Remote Engine Start Activation Horn Honk Diagnostics.....	23
Remote Engine Start Diagnostic Mode.....	24
Advanced Troubleshooting .....	25
“The RES system will not run for the full default 15–minute run time” .....	25
“The RES system will not operate when activated multiple times in a row” .....	25
“The RES system shuts down when any vehicle door, trunk or rear gate is opened” .....	26
“The vehicle starts by itself without pressing the RES transmitter button.....	26
“The SSM IV (DST–i) screen displays “Registration Failure” when attempting to register the RES control module to the vehicle” .....	27
“CAN Diagnostic Trouble Codes ( “U codes” ) are triggered in the vehicle” .....	28
“The vehicle’ s ignition turns ON when the RES system is activated, but it does not crank the starter” .....	29
“The RES system does not turn ON the vehicle’ s ignition circuits after receiving the remote start command” .....	30
“The vehicle starts when the RES system is activated, but the heater / air conditioning does not turn ON” .....	31
“The RES system does not respond when the RES transmitter button is pressed 2–times” ..	32
“The RES system bi–directional feature does not function” .....	33
“The vehicle’ s ignition turns ON and the horn honks two (2) times when activating the RES system” .....	34
Advanced Troubleshooting Video Links .....	35

## Remote Engine Start System Part Matrix (Impreza/Crosstrek Key Start Models)

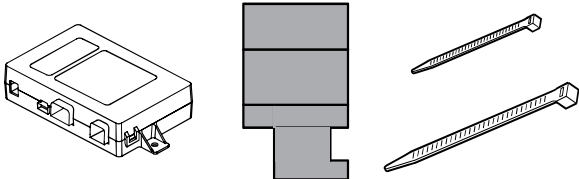
<b>Application / Model Years</b>	<b>Impreza 2017-2018MY Crosstrek 2018MY</b>
<b>Complete RES Kit Part Numbers</b>	<b>H001SFL100 / 101</b>
<b>Service Part Numbers</b>	
RES ECU Replacement Kit	H001SFL110
RES Bi-Directional Fob Replacement Kit (Qty 1)	H001SFL020
Ignition/Prewire Harness Replacement Kit	H001SFL130
Hood Switch / Bracket Replacement Kit	H001SFL040

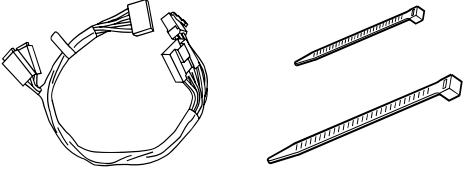
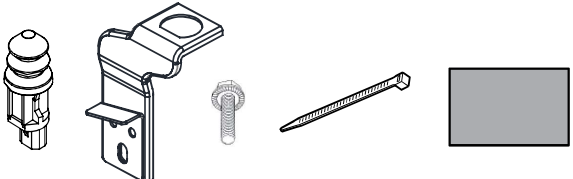
<p><b>H001SFL110 RES ECU Replacement Kit</b></p>  <p>Includes (1) ECU, (1) adhesive-backed foam mounting pad, (1) 8" tie wrap, (1) 15" tie wrap and installation instructions</p>	<p><b>H001SFL020 RES Bi-Directional Fob</b></p>  <p>Includes (1) B-Directional fob and programming instructions</p>
<p><b>H001SFL130 Ignition/Prewire Harness Replacement Kit</b></p>  <p>Includes (1) wire harness, (5) 8" tie wraps and (8) 15" tie wraps</p>	<p><b>H001SFL040 Hood Switch / Bracket Replacement Kit</b></p>  <p>Includes (1) hood switch, (1) mounting bracket, (1) M6 bolt, (1) 8" tie wrap and (1) adhesive backed foam tape</p>

Please Note: The service part numbers referenced above are current as of the revision of this document. Please check with your parts department for verification.

## Remote Engine Start System Part Matrix (Impreza/Crosstrek Key Start Models)

<b>Application / Model Years</b>	<b>Impreza 2019MY+ Crosstrek 2019MY+</b>
<b>Complete RES Kit Part Numbers</b>	<b>H001SFL400 / 401</b>
<b>Service Part Numbers</b>	
RES ECU Replacement Kit	H001SFL411
RES Bi-Directional Fob Replacement Kit (Qty 1)	H001SFL020
Ignition/Prewire Harness Replacement Kit	H001SFL420

### H001SFL411 RES ECU Replacement Kit

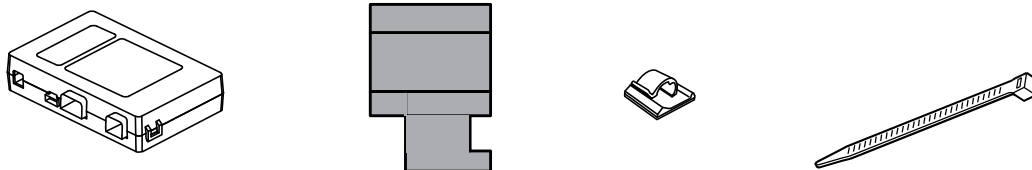

Includes (1) ECU, (1) adhesive-backed foam mounting pad, (1) wire harness clip, (1) 15" tie wrap and installation instructions

### H001SFL020 RES Bi-Directional Fob



Includes (1) B-Directional fob and programming instructions

### H001SFL420 Ignition/Prewire Harness Replacement Kit

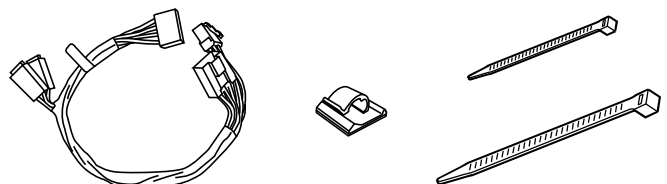

Includes (1) wire harness, (1) wire harness clip, (4) 8" tie wraps and (8) 15" tie wraps

Please Note: The service part numbers referenced above are current as of the revision of this document. Please check with your parts department for verification.

## Remote Engine Start System Part Matrix (Ascent Key Start Models)

<b>Application / Model Years</b>	<b>Ascent 2019MY+</b>
<b>Complete RES Kit Part Numbers</b>	<b>H001SXC100</b>
<b>Service Part Numbers</b>	
RES ECU Replacement Kit	H001SXC110
RES Bi-Directional Fob Replacement Kit (Qty 1)	H001SFL020
Ignition/Prewire Harness Replacement Kit	H001SXC120

**H001SXC110  
RES ECU Replacement Kit**

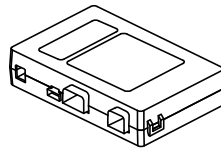

Includes (1) ECU, (1) mounted adhesive-backed foam mounting pad and installation instructions

**H001SFL020  
RES Bi-Directional Fob**



Includes (1) B-Directional fob and programming instructions

**H001SXC120  
Ignition/Prewire Harness Replacement Kit**

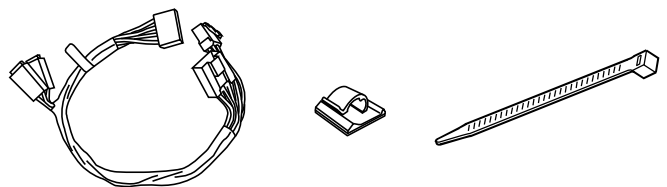

Includes (1) wire harness, (5) wire harness clips and (6) 15" tie wraps

Please Note: The service part numbers referenced above are current as of the revision of this document. Please check with your parts department for verification.

## Remote Engine Start System Part Matrix (Forester Key Start Models)

<b>Application / Model Years</b>	<b>Forester 2019MY+</b>
<b>Complete RES Kit Part Numbers</b>	<b>H001SSJ100</b>
<b>Service Part Numbers</b>	
RES ECU Replacement Kit	H001SSJ110
RES Bi-Directional Fob Replacement Kit (Qty 1)	H001SFL020
Ignition/Prewire Harness Replacement Kit	H001SSJ120

**H001SSJ110  
RES ECU Replacement Kit**



Includes (1) ECU, (1) mounted adhesive-backed foam mounting pad, (1) 15" tie wrap and installation instructions

**H001SFL020  
RES Bi-Directional Fob**



Includes (1) B-Directional fob and programming instructions

**H001SSJ120  
Ignition/Prewire Harness Replacement Kit**

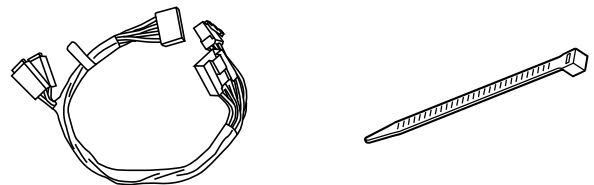

Includes (1) wire harness and (6) 15" tie wraps

Please Note: The service part numbers referenced above are current as of the revision of this document. Please check with your parts department for verification.

## Remote Engine Start System Part Matrix (Legacy/Outback Key Start Models)

Application / Model Years	Legacy/Outback 2020MY+
<b>Complete RES Kit Part Numbers</b>	<b>H001SAN100 / 101</b>
<b>Service Part Numbers</b>	
RES ECU Replacement Kit	H001SAN111
RES ECU Mounting Bracket Replacement Kit	H001SAN020
RES Bi-Directional Fob Replacement Kit (Qty 1)	H001SFL020
Jumper Prewire Harness Replacement Kit	H001SAN130

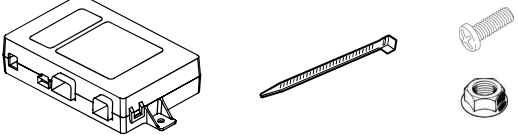
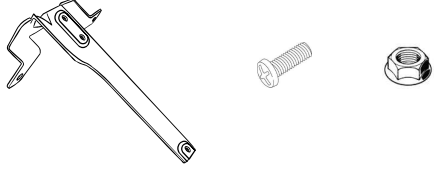
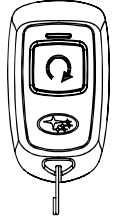
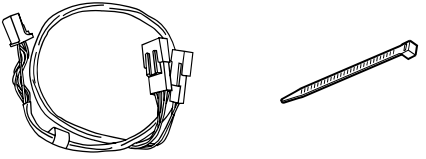
<p><b>H001SAN111</b> <b>RES ECU Replacement Kit</b></p>  <p>Includes (1) ECU, (3) 15" tie wraps, (2) Phillips screws, (2) Hex nuts and installation instructions</p>	<p><b>H001SAN020</b> <b>RES ECU Mounting Bracket Replacement Kit</b></p>  <p>Includes (1) ECU mounting bracket, (2) Phillips screws, (2) Hex nuts and installation instructions</p>
<p><b>H001SFL020</b> <b>RES Bi-Directional Fob</b></p>  <p>Includes (1) B-Directional fob and programming instructions</p>	<p><b>H001SAN130</b> <b>Jumper Prewire Harness Replacement Kit</b></p>  <p>Includes (1) jumper wire harness and (3) 15" tie wraps</p>

Please Note: The service part numbers referenced above are current as of the revision of this document. Please check with your parts department for verification.

## Remote Engine Start System Part Matrix (WRX Key Start Models)

<b>Application / Model Years</b>	<b>WRX 2022MY+</b>
<b>Complete RES Kit Part Numbers</b>	<b>H001SVC100</b>
<b>Service Part Numbers</b>	
RES ECU Replacement Kit	H001SVC110
RES Bi-Directional Fob Replacement Kit (Qty 1)	H001SFL020
Jumper Prewire Harness Replacement Kit	H001SVC130

**H001SVC110  
RES ECU Replacement Kit**

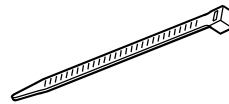
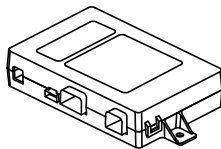

Includes (1) ECU, (1) mounted adhesive-backed foam mounting pad, (2) 15" tie wraps and installation instructions

**H001SFL020  
RES Bi-Directional Fob**



Includes (1) B-Directional fob and programming instructions

**H001SVC130  
Jumper Prewire Harness Replacement Kit**

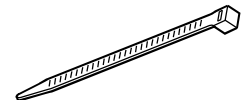

Includes (1) wire harness and (4) 15" tie wraps

Please Note: The service part numbers referenced above are current as of the revision of this document. Please check with your parts department for verification.



2017-2018MY Impreza and Crosstrek Key Start Vehicles

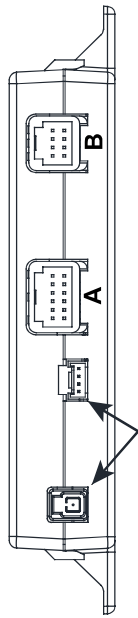

Not Used

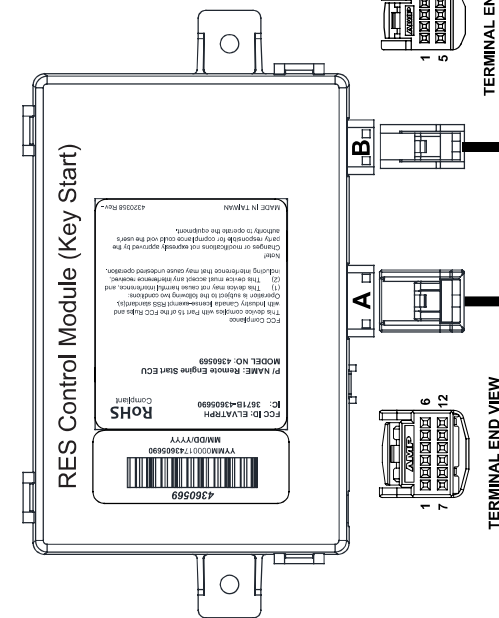

"Detail B" 8-pin RES ECU Ignition Connector

Pin	Wire Color	Function	In / Out	Pol.	Description
1	Blue/Green	Battery Feed 1 (AM1)	Input	+	Battery feed to ignition and accessory RES ECU internal relays. 12V+ at all times
2	Open	N/A	N/A	N/A	N/A
3	Open	N/A	N/A	N/A	N/A
4	Green	Ignition	Input / Output	+	Ignition input to RES ECU when ignition key is turned on, RES ignition output
5	Gray	Starter/Crank	Output	+	RES starter/crank output
6	Yellow	Accessory	Output	+	RES accessory output
7	Blue	Battery Feed 2 (AM2)	Input	+	Battery feed to starter/crank RES ECU internal relay. 12V+ at all times
8	Open	N/A	N/A	N/A	N/A

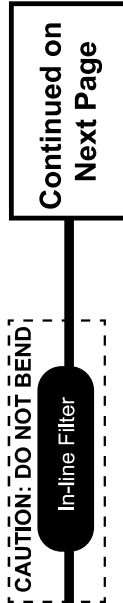

Continued on Next Page

"Detail A" 12-pin RES ECU Main Connector

Pin	Wire Color	Function	In / Out	Pol.	Description
1	Orange	Power Window Interrupt	N/A	N/A	Interrupts ground trigger to power window ignition relay during RES. Not polarity sensitive
2	Blue/Red	Battery 1 (AM1)	Input	+	Main battery + input to RES ECU. +12 volts at all times
3	Blue	CAN Low	N/A	Data	High Speed CAN data transmit / receive
4	Open	N/A	N/A	N/A	N/A
5	Open	N/A	N/A	N/A	N/A
6	Black/Red	Chassis Ground	Input	-	Chassis ground input to RES system
7	Open	N/A	N/A	N/A	N/A
8	Black	Power Window Interrupt	N/A	N/A	Interrupts ground trigger to power window ignition relay during RES. Not polarity sensitive
9	Red	CAN High	N/A	Data	High Speed CAN data transmit / receive
10	White	Hood Safety Switch Input	Input	-	Ground input to RES system with hood open, neutral with hood closed
11	Open	N/A	N/A	N/A	N/A
12	Open	N/A	N/A	N/A	N/A

Engine Compartment:

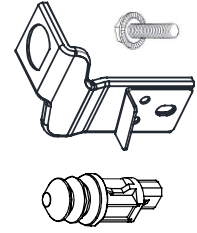

The RES Hood safety switch and bracket mount to the passenger's fender near the vehicle relay box. The 2-pin pre-arranged connector plugs into the RES Hood safety switch.

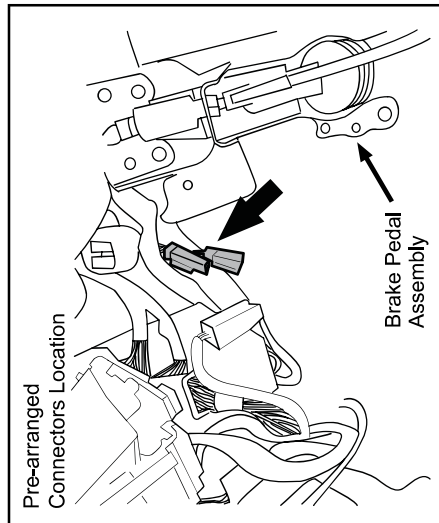
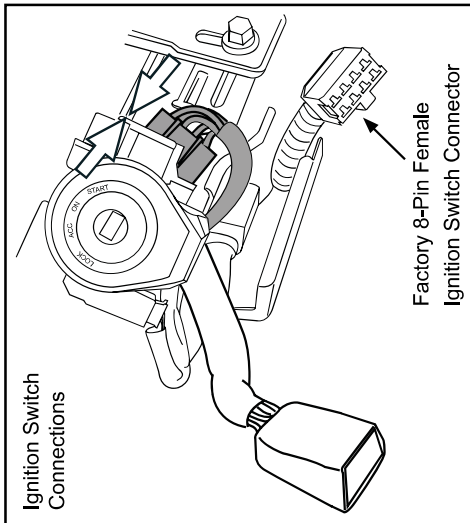

Detail C - Mates with vehicle ignition switch connector

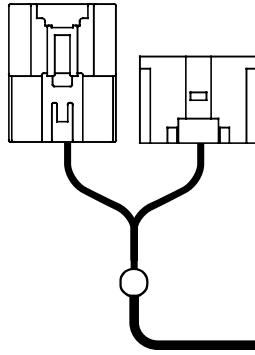

Detail C - Mates with vehicle ignition switch

Detail D - Mates with 2-pin pre-arranged vehicle connector

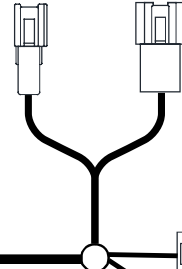

Detail E - Mates with 4-pin pre-arranged vehicle connector

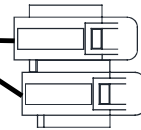

10 AMP Fuses  
Battery 1 &  
Battery 2

Continued From Previous Page



## "Detail C" 8-pin Ignition Switch Connectors

Pin	Wire Color	Function	In / Out	Pol.	Description
1	Green	Ignition	In & Out	+	RES ignition output, ignition input to RES ECU when ignition key is turned on
2	Yellow	Accessory	Output	+	RES accessory output
3	Open	N/A	N/A	N/A	N/A
4	Blue/Green	Battery Feed 1 (AM1)	Input	+	Battery feed to ignition and accessory RES ECU internal relays. 12V+ at all times
5	Blue	Battery Feed 2 (AM2)	Input	+	Battery feed to starter/crank RES ECU internal relay. 12V+ at all times
6	Open	N/A	N/A	N/A	N/A
7	Gray	Starter/Crank	Output	+	RES starter/crank output
8	Open	N/A	N/A	N/A	N/A



## "Detail D" 2-pin Pre-arranged Connector

Pin	Wire Color	Function	In / Out	Pol.	Description
1	Orange	Power Window Interrupt	N/A	N/A	Interrupts ground trigger to power window ignition relay during RES. Not polarity sensitive
2	Black	Power Window Interrupt	N/A	N/A	Interrupts ground trigger to power window ignition relay during RES. Not polarity sensitive

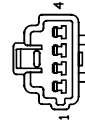

## "Detail E" 4-pin Pre-arranged Connector

Pin	Wire Color	Function	In / Out	Pol.	Description
1	White	Hood Safety Switch Input	Input	-	Registers ground with hood is open, rests open when hood is closed
2	Black/White	Chassis Ground	Input	-	Chassis ground input to RES system
3	Blue	CAN Low	N/A	Data	High Speed CAN data transmit / receive
4	Red	CAN High	N/A	Data	High Speed CAN data transmit / receive

2019MY+ Impreza and Crosstrek Key Start Vehicles

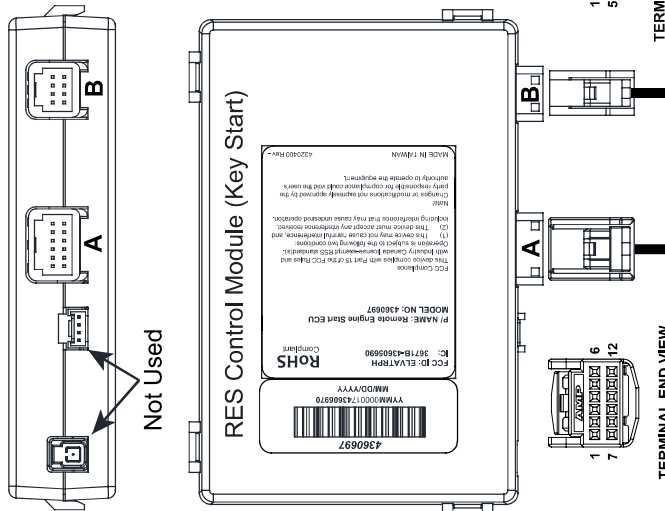

"Detail B" 8-pin RES ECU Ignition Connector

Pin	Wire Color	Function	In / Out	Pol.	Description
1	Blue/Green	Battery Feed 1 (AM1)	Input	+	Battery feed to ignition and accessory RES ECU internal relays. 12V+ at all times
2	Open	N/A	N/A	N/A	N/A
3	Open	N/A	N/A	N/A	N/A
4	Green	Ignition	Input / Output	+	Ignition input to RES ECU when ignition key is turned on, RES ignition output
5	Gray	Starter/Crank	Output	+	RES starter/crank output
6	Yellow	Accessory	Output	+	RES accessory output
7	Blue	Battery Feed 2 (AM2)	Input	+	Battery feed to starter/crank RES ECU internal relay. 12V+ at all times
8	Open	N/A	N/A	N/A	N/A

Continued on Next Page

"Detail A" 12-pin RES ECU Main Connector

Pin	Wire Color	Function	In / Out	Pol.	Description
1	Orange	Power Window Interrupt	N/A	N/A	Interrupts ground trigger to power-window ignition relay during RES. Not polarity sensitive
2	Blue/Green	Battery 1 (AM1)	Input	+	Main battery + input to RES ECU, +12 volts at all times
3	Blue	CAN Low	N/A	Data	High Speed CAN data transmit / receive
4	Open	N/A	N/A	N/A	N/A
5	Open	N/A	N/A	N/A	N/A
6	Black/White	Chassis Ground	Input	-	Chassis ground input to RES system
7	Open	N/A	N/A	N/A	N/A
8	Black	Power-Window Interrupt	N/A	N/A	Interrupts ground trigger to power-window ignition relay during RES. Not polarity sensitive
9	Red	CAN High	N/A	Data	High Speed CAN data transmit / receive
10	White	Hood Safety Switch Input	Input	-	Ground input to RES system with hood open, neutral with hood closed
11	Open	N/A	N/A	N/A	N/A
12	Open	N/A	N/A	N/A	N/A

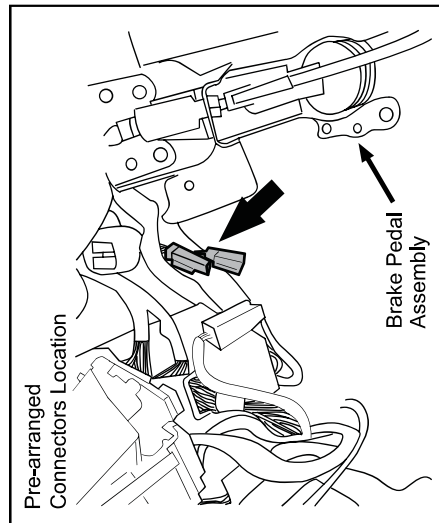
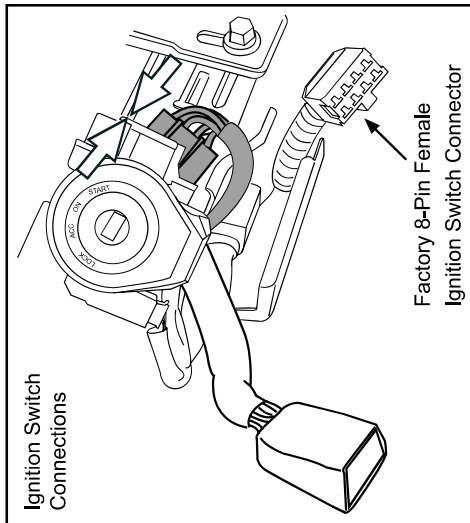

Detail C - Mates with vehicle ignition switch connector

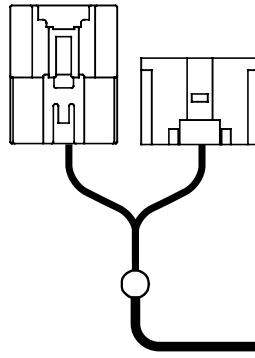

Detail C - Mates with vehicle ignition switch

Detail D - Mates with 2-pin pre-arranged vehicle connector

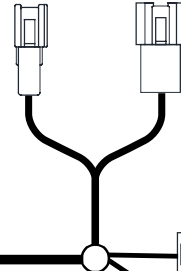

Detail E - Mates with 4-pin pre-arranged vehicle connector

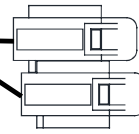

10 AMP Fuses Battery 1 & Battery 2

Continued From Previous Page

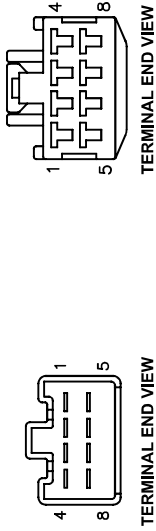

## "Detail C" 8-pin Ignition Switch Connectors

Pin	Wire Color	Function	In / Out	Pol.	Description
1	Green	Ignition	In & Out	+	RES ignition output, ignition input to RES ECU when ignition key is turned on
2	Yellow	Accessory	Output	+	RES accessory output
3	Open	N/A	N/A	N/A	N/A
4	Blue/Green	Battery Feed 1 (AM1)	Input	+	Battery feed to ignition and accessory RES ECU internal relays. 12V+ at all times
5	Blue	Battery Feed 2 (AM2)	Input	+	Battery feed to starter/crank RES ECU internal relay. 12V+ at all times
6	Open	N/A	N/A	N/A	N/A
7	Gray	Starter/Crank	Output	+	RES starter/crank output
8	Open	N/A	N/A	N/A	N/A



## "Detail D" 2-pin Pre-arranged Connector

Pin	Wire Color	Function	In / Out	Pol.	Description
1	Orange	Power Window Interrupt	N/A	N/A	Interrupts ground trigger to power window ignition relay during RES. Not polarity sensitive
2	Black	Power Window Interrupt	N/A	N/A	Interrupts ground trigger to power window ignition relay during RES. Not polarity sensitive

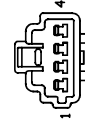

## "Detail E" 4-pin Pre-arranged Connector

Pin	Wire Color	Function	In / Out	Pol.	Description
1	White	Hood Safety Switch Input	Input	-	Registers ground with hood is open, rests open when hood is closed
2	Black/White	Chassis Ground	Input	-	Chassis ground input to RES system
3	Blue	CAN Low	N/A	Data	High Speed CAN data transmit / receive
4	Red	CAN High	N/A	Data	High Speed CAN data transmit / receive

2019MY+ Ascent and Forester Key Start Vehicles

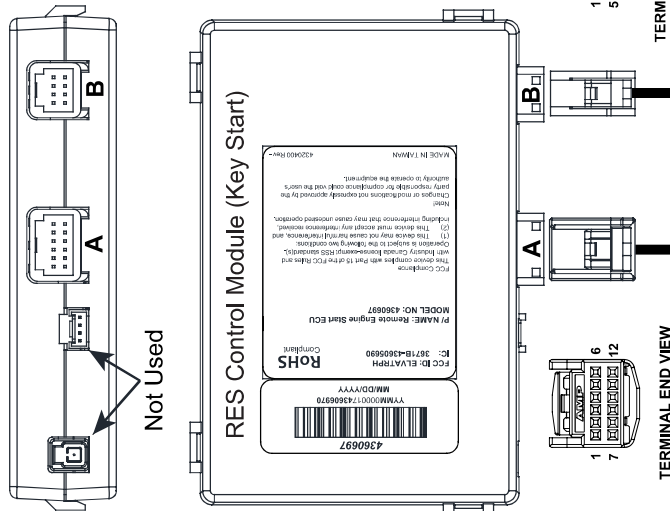

"Detail B" 8-pin RES ECU Ignition Connector

Pin	Wire Color	Function	In / Out	Pol.	Description
1	Blue/Red	Battery Feed 1 (AM1)	Input	+	Battery feed to ignition and accessory RES ECU internal relays. 12V+ at all times
2	Open	N/A	N/A	N/A	N/A
3	Open	N/A	N/A	N/A	N/A
4	Gray	Ignition	Input / Output	+	Ignition input to RES ECU when ignition key is turned on, RES ignition output
5	Green	Starter/Crank	Output	+	RES starter/crank output
6	Green/Yellow	Accessory	Output	+	RES accessory output
7	Blue/Green	Battery Feed 2 (AM2)	Input	+	Battery feed to starter/crank RES ECU internal relay. 12V+ at all times
8	Open	N/A	N/A	N/A	N/A

Continued on Next Page

"Detail A" 12-pin RES ECU Main Connector

Pin	Wire Color	Function	In / Out	Pol.	Description
1	Orange	Power Window Interrupt	N/A	N/A	Interrupts ground trigger to power window ignition relay during RES. Not polarity sensitive
2	Blue/Red	Battery 1 (AM1)	Input	+	Main battery + input to RES ECU. +12 volts at all times
3	Blue	CAN Low	N/A	Data	High Speed CAN data transmit / receive
4	Open	N/A	N/A	N/A	N/A
5	Open	N/A	N/A	N/A	N/A
6	Black/White	Chassis Ground	Input	-	Chassis ground input to RES system
7	Open	N/A	N/A	N/A	N/A
8	Black	Power Window Interrupt	N/A	N/A	Interrupts ground trigger to power-window ignition relay during RES. Not polarity sensitive
9	Red	CAN High	N/A	Data	High Speed CAN data transmit / receive
10	Open	N/A	N/A	N/A	N/A
11	Open	N/A	N/A	N/A	N/A
12	Open	N/A	N/A	N/A	N/A

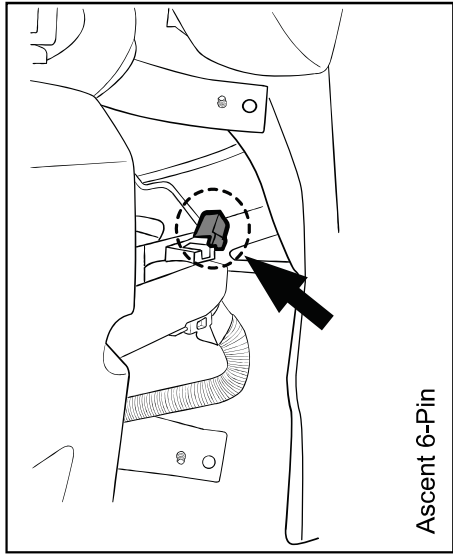

Detail C - Mates with 6-pin pre-arranged ignition connector

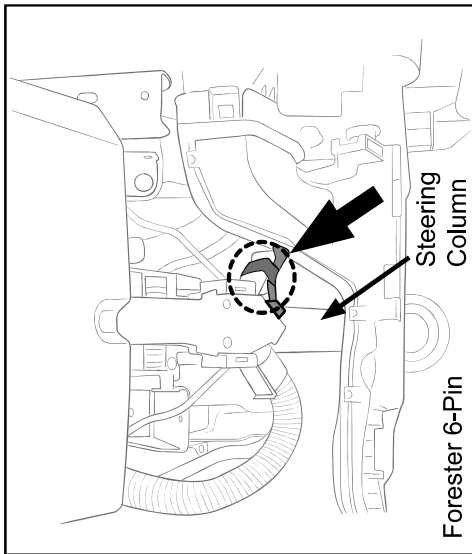
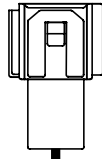

Detail D - Mates with 2-pin pre-arranged vehicle connector

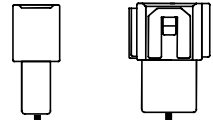

Detail E - Mates with 4-pin pre-arranged vehicle connector

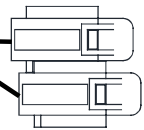

10 AMP Fuses  
Battery 1 &  
Battery 2

Continued From  
Previous Page

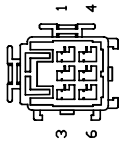

TERMINAL END VIEW "Detail C" 6-pin Pre-arranged Ignition Connector

Pin	Wire Color	Function	In / Out	Pol.	Description
1	Blue/Red	Battery Feed 1 (AM1)	Input	+	Battery feed to ignition and accessory RES ECU internal relays. 12V+ at all times
2	Blue/Green	Battery Feed 2 (AM2)	Input	+	Battery feed to starter/crank RES ECU internal relays. 12V+ at all times
3	Green/Yellow	Accessory	Output	+	RES accessory output
4	Gray	Ignition	Input / Output	+	Ignition input to RES ECU when ignition is turned on. RES ignition output
5	Green	Starter/Crank	Output	+	RES starter/crank output
6	Open	N/A	N/A	N/A	N/A



TERMINAL END VIEW "Detail D" 2-pin Pre-arranged Connector

Pin	Wire Color	Function	In / Out	Pol.	Description
1	Orange	Power Window Interrupt	N/A	N/A	Interrupts ground trigger to power window ignition relay during RES. Not polarity sensitive
2	Black	Power Window Interrupt	N/A	N/A	Interrupts ground trigger to power window ignition relay during RES. Not polarity sensitive



TERMINAL END VIEW "Detail E" 4-pin Pre-arranged Connector

Pin	Wire Color	Function	In / Out	Pol.	Description
1	Red	CAN High	N/A	Data	High Speed CAN data transmit / receive
2	Blue	CAN Low	N/A	Data	High Speed CAN data transmit / receive
3	Black/White	Chassis Ground	Input	-	Chassis ground input to RES system
4	Open	N/A	N/A	N/A	N/A

2020MY+ Legacy and Outback Key Start Vehicles

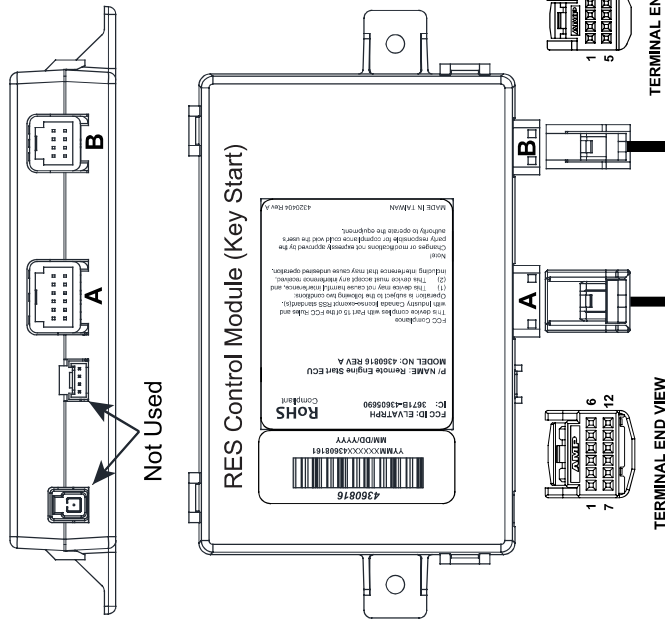

"Detail B" 8-pin RES ECU Ignition Connector

Pin	Wire Color	Function	In / Out	Pol.	Description
1	Blue/Red	Battery Feed 1 (AM1)	Input	+	Battery feed to ignition and accessory RES ECU internal relays. 12V+ at all times
2	Open	N/A	N/A	N/A	N/A
3	Open	N/A	N/A	N/A	N/A
4	Green/Red	Ignition	Input / Output	+	Ignition input to RES ECU when ignition key is turned on. RES ignition output
5	Brown	Starter/Crank	Output	+	RES starter/crank output
6	Green/Yellow	Accessory	Output	+	RES accessory output
7	Blue/Green	Battery Feed 2 (AM2)	Input	+	Battery feed to starter/crank RES ECU internal relay. 12V+ at all times
8	Open	N/A	N/A	N/A	N/A

Continued on Next Page

"Detail A" 12-pin RES ECU Main Connector

Pin	Wire Color	Function	In / Out	Pol.	Description
1	Green	Power Window Interrupt	N/A	N/A	Interrupts ground trigger to power window ignition relay during RES. Not polarity sensitive
2	Blue/Red	Battery 1 (AM1)	Input	+	Main battery + input to RES ECU. +12 volts at all times
3	Gray/Red	CAN Low	Data	N/A	High Speed CAN data transmit / receive
4	Open	N/A	N/A	N/A	N/A
5	Open	N/A	N/A	N/A	N/A
6	Black	Chassis Ground	Input	-	Chassis ground input to RES system
7	Open	N/A	N/A	N/A	N/A
8	Blue	Power Window Interrupt	N/A	N/A	Interrupts ground trigger to power window ignition relay during RES. Not polarity sensitive
9	White/Red	CAN High	Data	N/A	High Speed CAN data transmit / receive
10	Open	N/A	N/A	N/A	N/A
11	Open	N/A	N/A	N/A	N/A
12	Open	N/A	N/A	N/A	N/A

**"Detail D" 8-pin Pre-arranged Connector**

Pin	Wire Color	Function	In / Out	Pol.	Description
1	Blue/Red	Battery Feed 1 (AM1)	Input	+	Battery feed to ignition and accessory RES ECU internal relays. 12V+ at all times
2	Open	N/A	N/A	N/A	N/A
3	Open	N/A	N/A	N/A	N/A
4	Green/Red	Ignition	Input / Output	+	Ignition input to RES ECU when ignition key is turned on, RES ignition output
5	Brown	Starter/Crank	Output	+	RES starter/crank output
6	Green/Yellow	Accessory	Output	+	RES accessory output
7	Blue/Green	Battery Feed 2 (AM2)	Input	+	Battery feed to starter/crank RES ECU internal relay. 12V+ at all times
8	Open	N/A	N/A	N/A	N/A

Detail D - Mates with 8-pin pre-arranged vehicle connector

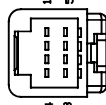

Detail C - Mates with 12-pin pre-arranged vehicle connector

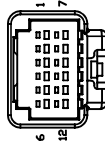

TERMINAL END VIEW

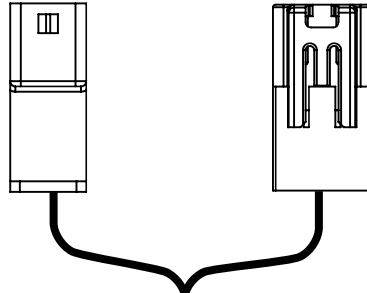

**"Detail C" 12-pin Pre-arranged Connector**

Pin	Wire Color	Function	In / Out	Pol.	Description
1	Green	Power Window Interrupt	N/A	N/A	Interrupts ground trigger to power window ignition relay during RES. Not polarity sensitive
2	Open	N/A	N/A	N/A	N/A
3	Gray/Red	CAN Low	N/A	Data	High Speed CAN data transmit / receive
4	Open	N/A	N/A	N/A	N/A
5	Open	N/A	N/A	N/A	N/A
6	Black	Chassis Ground	Input	-	Chassis ground input to RES system
7	Open	N/A	N/A	N/A	N/A
8	Blue	Power Window Interrupt	N/A	N/A	Interrupts ground trigger to power window ignition relay during RES. Not polarity sensitive
9	White/Red	CAN High	N/A	Data	High Speed CAN data transmit / receive
10	Open	N/A	N/A	N/A	N/A
11	Open	N/A	N/A	N/A	N/A
12	Open	N/A	N/A	N/A	N/A

Continued From Previous Page

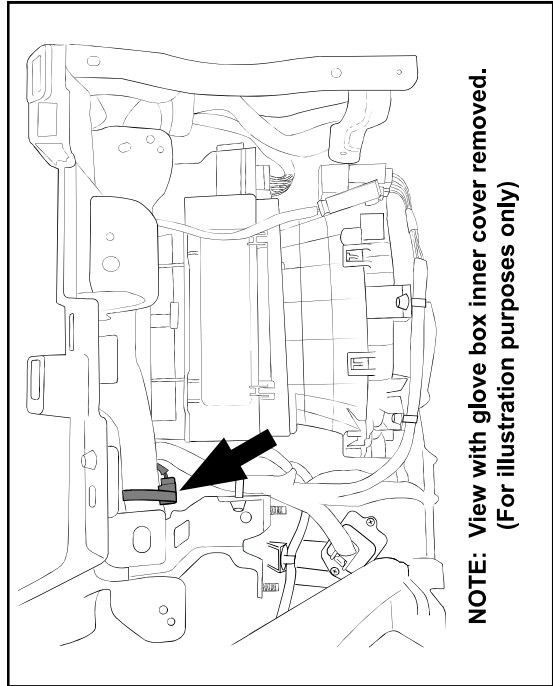

NOTE: View with glove box inner cover removed. (For illustration purposes only)

Pre-arranged Connector Location



2022MY+ WRX Key Start Vehicles

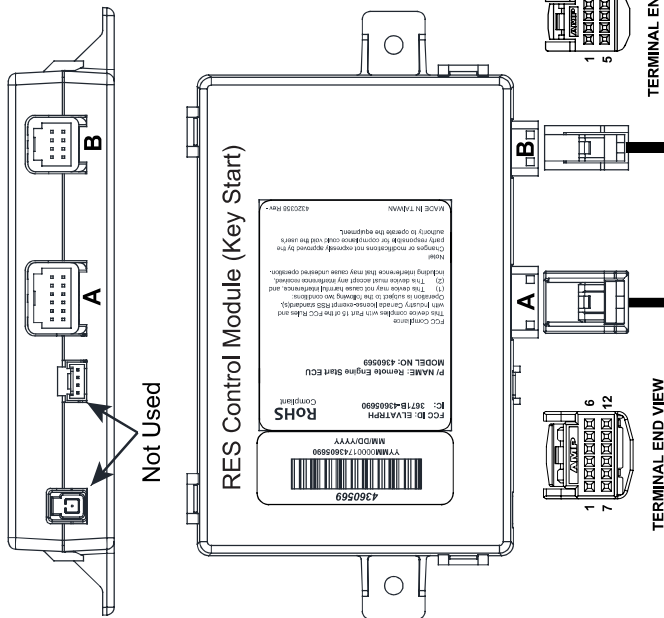

"Detail B" 8-pin RES ECU Ignition Connector

Pin	Wire Color	Function	In / Out	Pol.	Description
1	Blue/Red	Battery Feed 1 (AM1)	Input	+	Battery feed to ignition and accessory RES ECU internal relays. 12V+ at all times
2	Open	N/A	N/A	N/A	N/A
3	Open	N/A	N/A	N/A	N/A
4	Green/Red	Ignition	Input / Output	+	Ignition input to RES ECU when ignition key is turned on. RES ignition output
5	Brown	Starter/Crank	Output	+	RES starter/crank output
6	Green/Yellow	Accessory	Output	+	RES accessory output
7	Blue/Green	Battery Feed 2 (AM2)	Input	+	Battery feed to starter/crank RES ECU internal relay. 12V+ at all times
8	Open	N/A	N/A	N/A	N/A

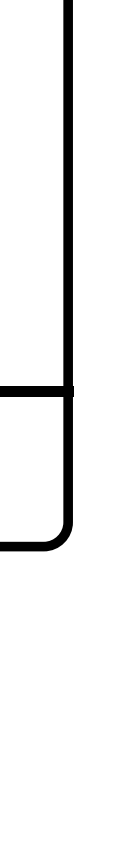
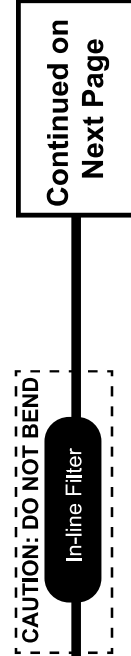

Continued on Next Page

"Detail A" 12-pin RES ECU Main Connector

Pin	Wire Color	Function	In / Out	Pol.	Description
1	Green	Power Window Interrupt	N/A	N/A	Interrupts ground trigger to power window ignition relay during RES. Not polarity sensitive
2	Blue/Green	Battery 1 (AM1)	Input	+	Main battery + input to RES ECU. +12 volts at all times
3	Gray/Red	CAN Low	N/A	Data	High Speed CAN data transmit / receive
4	Open	N/A	N/A	N/A	N/A
5	Open	N/A	N/A	N/A	N/A
6	Black/White	Chassis Ground	Input	-	Chassis ground input to RES system
7	Open	N/A	N/A	N/A	N/A
8	Blue	Power Window Interrupt	N/A	N/A	Interrupts ground trigger to power window ignition relay during RES. Not polarity sensitive
9	White/Red	CAN High	N/A	Data	High Speed CAN data transmit / receive
10	Open	N/A	N/A	N/A	N/A
11	Open	N/A	N/A	N/A	N/A
12	Open	N/A	N/A	N/A	N/A

"Detail D" 8-pin Pre-arranged Connector

Pin	Wire Color	Function	In / Out	Pol.	Description
1	Blue/Red	Battery Feed 1 (AM1)	Input	+	Battery feed to ignition and accessory RES ECU internal relays. 12V+ at all times
2	Open	N/A	N/A	N/A	N/A
3	Open	N/A	N/A	N/A	N/A
4	Green/Red	Ignition	Input / Output	+	Ignition input to RES ECU when ignition key is turned on, RES ignition output
5	Brown	Starter/Crank	Output	+	RES starter/crank output
6	Green/Yellow	Accessory	Output	+	RES accessory output
7	Blue/Green	Battery Feed 2 (AM2)	Input	+	Battery feed to starter/crank RES ECU internal relay. 12V+ at all times
8	Open	N/A	N/A	N/A	N/A

Detail D - Mates with 8-pin pre-arranged vehicle connector

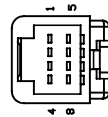

TERMINAL END VIEW

Detail C - Mates with 12-pin pre-arranged vehicle connector

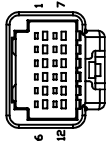

"Detail C" 12-pin Pre-arranged Connector

Pin	Wire Color	Function	In / Out	Pol.	Description
1	Green	Power Window Interrupt	N/A	N/A	Interrupts ground trigger to power window ignition relay during RES. Not polarity sensitive
2	Open	N/A	N/A	N/A	N/A
3	Gray/Red	CAN Low	N/A	Data	High Speed CAN data transmit / receive
4	Open	N/A	N/A	N/A	N/A
5	Open	N/A	N/A	N/A	N/A
6	Black	Chassis Ground	Input	-	Chassis ground input to RES system
7	Open	N/A	N/A	N/A	N/A
8	Blue	Power Window Interrupt	N/A	N/A	Interrupts ground trigger to power window ignition relay during RES. Not polarity sensitive
9	White/Red	CAN High	N/A	Data	High Speed CAN data transmit / receive
10	Open	N/A	N/A	N/A	N/A
11	Open	N/A	N/A	N/A	N/A
12	Open	N/A	N/A	N/A	N/A

Continued From Previous Page

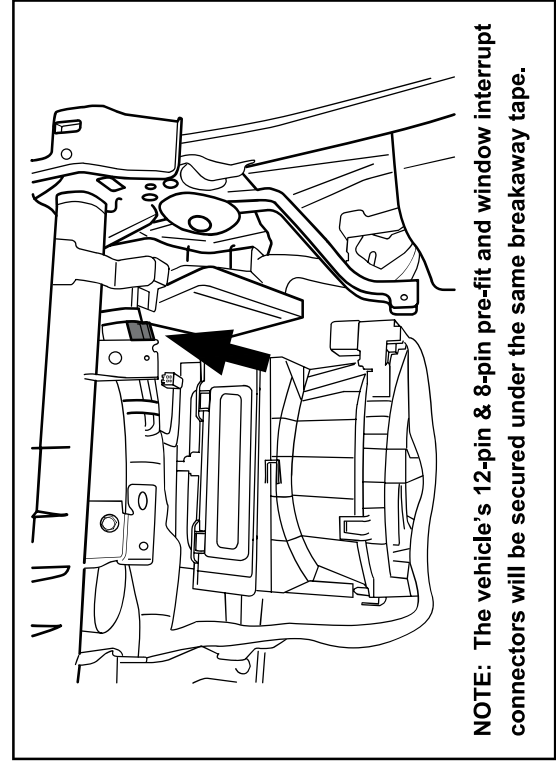

NOTE: The vehicle's 12-pin & 8-pin pre-fit and window interrupt connectors will be secured under the same breakaway tape.

Pre-arranged Connector Location

# Remote Engine Start Control Module Registration Procedure - SSM IV (DST-i) 17MY+ Impreza, 18MY+ Crosstrek, 19MY+ Ascent and 19-21MY Forester

**NOTE: Once the Ignition is turned ON, the RES system will exit System Registration after 2 minutes.**

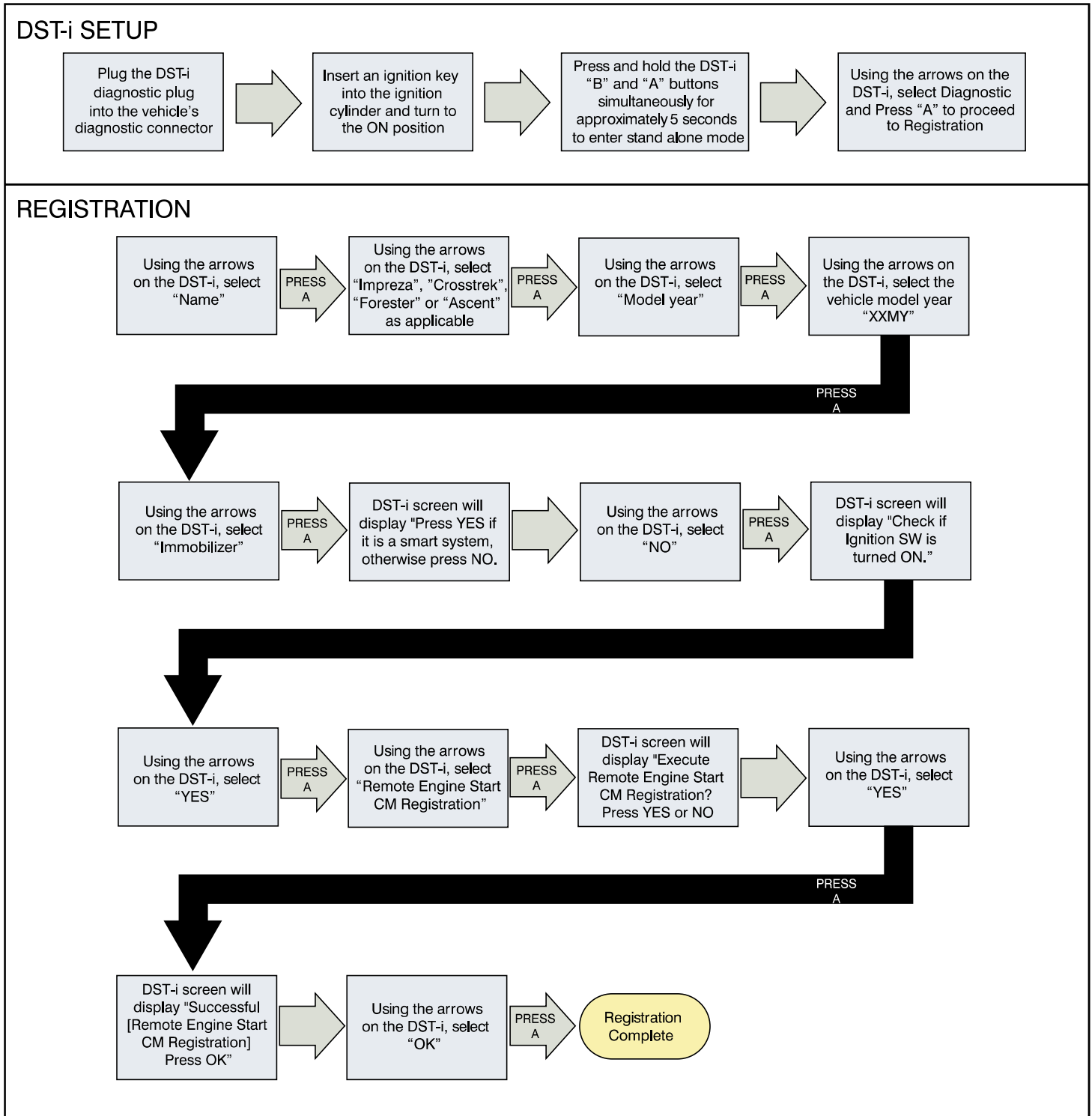

# Remote Engine Start Control Module Registration Procedure - SSM IV (DST-i) 20MY+ Legacy / Outback, 22MY+ Forester, 22MY+ WRX

**NOTE:** Requires Network-Enabled Laptop - Ensure software version is Revision 18.1.1 or newer (July 2019 update)

**NOTE:** Once the Ignition is turned ON, the RES system will exit System Registration after 2 minutes.

## DST-i SETUP



## REGISTRATION

1. PRESS IMMOBILIZER ETC. REGISTRATION AND PRESS SELECT

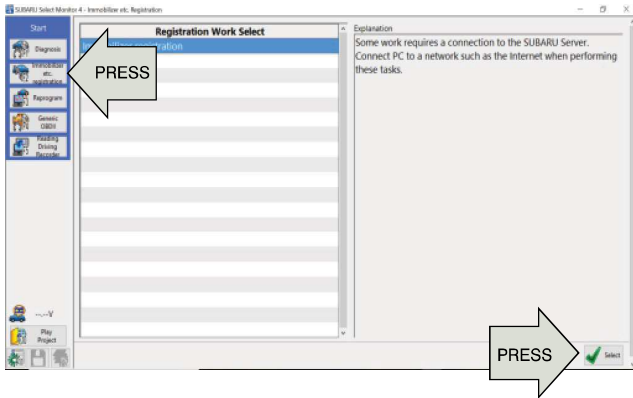

2. PRESS LEGACY AND PRESS SELECT

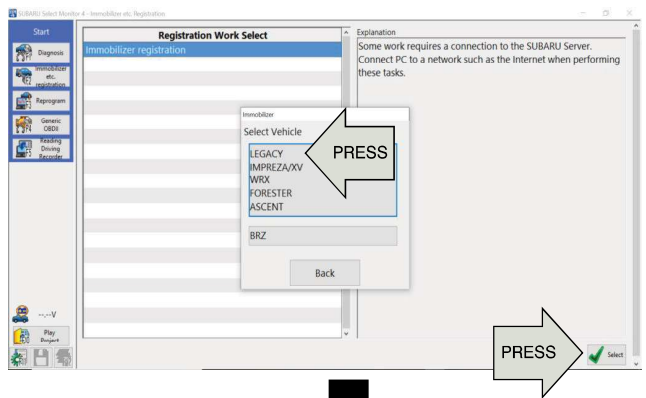

Insert an ignition key into the ignition cylinder and turn to the ON position

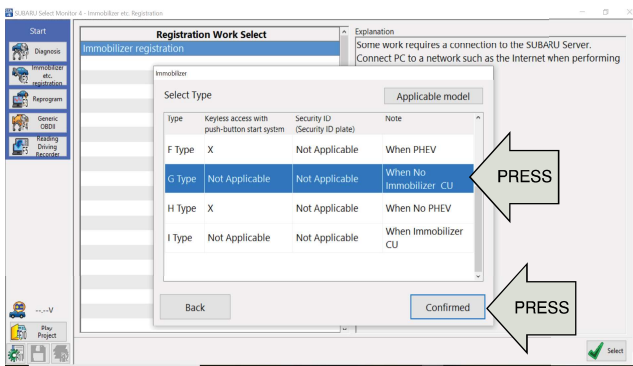

3. PRESS G TYPE FOR KEY START MODELS AND PRESS CONFIRMED

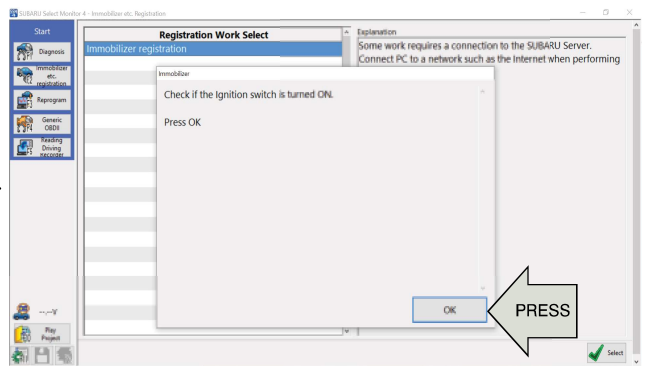

4. ENSURE THE IGNITION IS TURNED ON AND PRESS OK



# Remote Engine Start Control Module Registration Procedure - SSM IV (DST-i) 20MY+ Legacy / Outback, 22MY+ Forester, 22MY+ WRX

**NOTE: Requires Network-Enabled Laptop - Ensure software version is Revision 18.1.1 or newer (July 2019 update)**

**NOTE: Once the Ignition is turned ON, the RES system will exit System Registration after 2 minutes.**

## REGISTRATION, continued

### 5. PRESS REMOTE ENGINE START CM REGISTRATION AND PRESS CONFIRMED

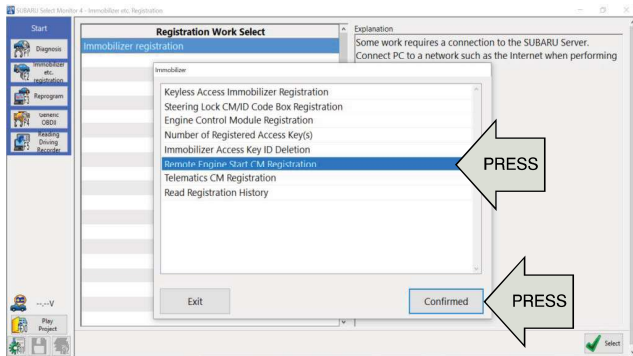

### 6. ENTER AUTHENTICATION KEY AND PRESS CONNECTION

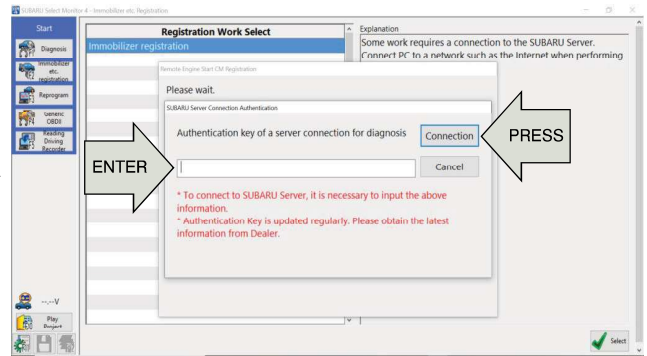

### 7. PRESS YES TO EXECUTE REGISTRATION

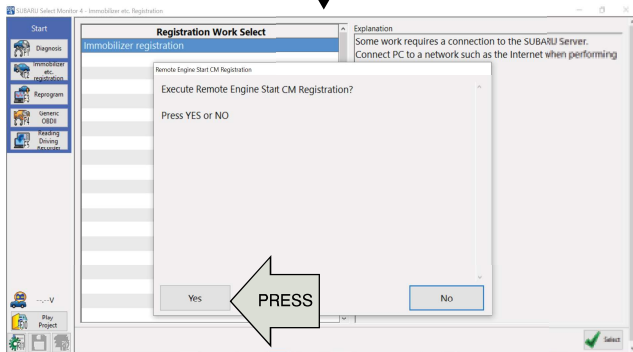

### 8. CONFIRM IGNITION IS ON AND PRESS OK

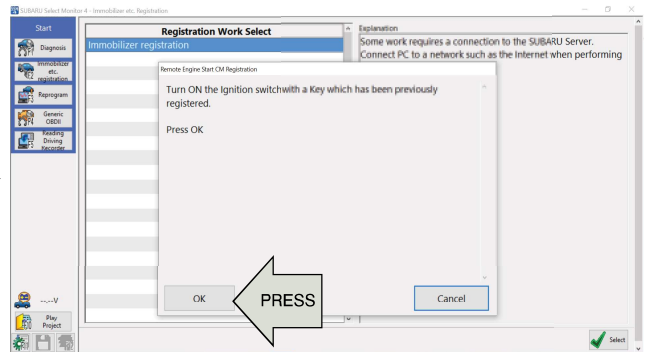

WAIT FOR BIU TO COMMUNICATE WITH RES CONTROL MODULE

### 9. REGISTRATION SUCCESSFUL, PRESS OK

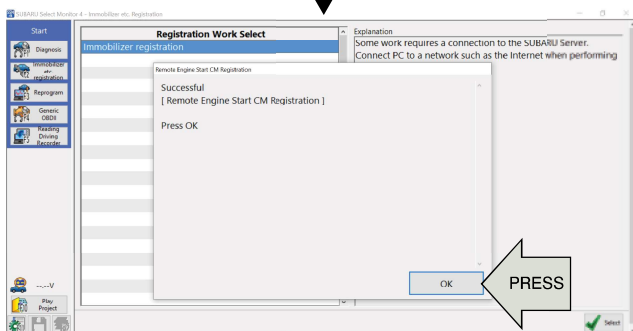

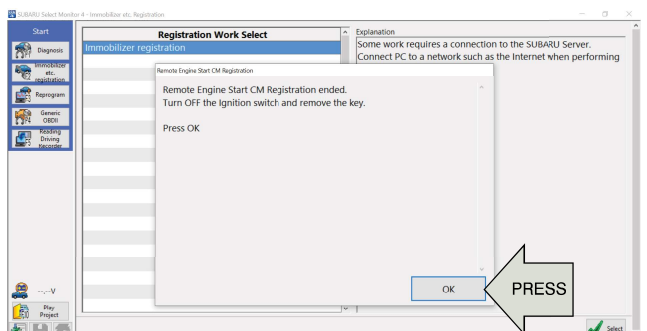

### 10. TURN OFF IGNITION AND PRESS OK



## Remote Engine Start Bi-directional Transmitter Programming Procedure

**NOTE: Up to eight (8) transmitters can be programmed to the remote engine start system.**

1. Open the driver's door and enter the vehicle. The driver's door must remain open throughout the entire programming process. Ensure all other vehicle doors, trunk, hatch or rear gate are closed.
2. Verify that the transmission shifter is in the "park" position.
3. Turn the ignition "ON" then "OFF", "ON" then "OFF", "ON" then "OFF", then back "ON" and leave on throughout the entire programming process. (ON/OFF ignition cycles must be completed within five (5) seconds.)
4. The system will flash the side marker lights, taillights and parking lights and honk the horn three (3) times indicating that the system has entered transmitter learn mode.
5. Press and hold the  button on the transmitter to be learned for three (3) seconds until the system flashes the side marker lights, taillights and parking lights and honks the horn one (1) time, indicating that the system has learned the transmitter. Release the  button. Upon successful programming, the remote start transmitter may flash/beep one (1) time.
6. Repeat step five (5) for additional transmitters. The system will accept up to eight (8) transmitters.
7. Turn the ignition OFF to exit transmitter learn mode.

**NOTE: The system will exit transmitter learn mode if the ignition is turned OFF, the driver's door is closed or thirty (30) seconds of inactivity.**

[Subaru RES Transmitter Programming - Video Link](#)

## Remote Engine Start Run Time Selection

**The system is pre-programmed to run for fifteen (15) minutes before automatically stopping. The programmed run time can be changed to alternate times using the following procedure.**

1. Enter the vehicle and close all vehicle doors, trunk or rear gate.
2. Verify that the transmission shifter is in the "park" position.
3. Turn the ignition "ON" then "OFF", "ON" then "OFF", "ON" then "OFF", then back "ON" and leave on throughout the programming process. (Four (4) ignition cycles ending in "ON" must be completed within eight (8) seconds.)
4. The system will honk the horn the number of times corresponding to the current run time setting.
5. Open and close the driver's door to advance to the next run time setting. The system will honk the horn the number of times corresponding to the new run time setting.
6. Turn the ignition OFF to exit run time selection mode.

Horn Honks	Run Time
1	Three (3) Minutes
2	Five (5) Minutes
3	Ten (10) Minutes
4	Fifteen (15) Minutes (Default Setting)

**NOTE: The system will exit run time selection mode if the ignition is turned OFF or thirty (30) seconds of inactivity. Upon exit, the current run time selection will be stored.**

[Subaru RES Selectable Run Time Programming - Video Link](#)

## Remote Engine Start Activation Horn Honk Diagnostics

When activating the remote engine start system, the vehicle will respond with various horn honks and exterior vehicle light flashes. The sequence of the horn honks/light flashes can help to differentiate between normal and abnormal operation and aid in troubleshooting. Below is a description of the various horn honk/light flash sequences and description of each function.

Horn Honk/Light Flash Sequence	System Operation / Failure Mode
One (1) horn honk/light flash immediately after activation from RES fob then one (1) horn honk/light flash following ignition power, starter crank and vehicle start.	Normal operation - Indicates RES system has received remote start request from RES fob, all safety parameters are correct and vehicle has successfully started.
Two (2) horn honks/light flashes immediately after activation from RES fob.	A safety check determined a failure which prevents the system from operating. Possible causes are: 1. Vehicle hood is open or safety switch is active. <a href="#">Prevent Remote Engine Start - Hood Switch - Video Link</a> 2. Vehicle brake pedal is pressed or switch is active. <a href="#">Prevent Remote Engine Start - Brake Switch - Video Link</a>
One (1) horn honk/light flash immediately after activation from RES fob. Followed by a pause and then two additional horn honks/light flashes.	A safety check determined a failure which prevents the system from operating. Possible causes are: 1. Vehicle hood is open or safety switch is active. 2. Vehicle brake pedal is pressed or switch is active. 3. Ignition key is resting in the ignition cylinder or the "key chime" circuit is active. <a href="#">Prevent Remote Engine Start - Key In Ignition - Video Link</a> 4. Transmission shifter is not in the PARK position. <a href="#">Prevent Remote Engine Start - Shifter Out of Park - Video Link</a>
Three (3) horn honks/light flashes immediately after activation from RES fob.	The RES system has detected one of the following operational failures: 1. Remote start has exceeded the maximum 20 minute run time duration between physical ignition key cycles. Cycle ignition key ON then OFF to clear max run timer. OR 2. A vehicle related issue (DTC) is requiring RES to abort operation. Correct vehicle issue and retry activation.
Four (4) horn honks/light flashes immediately after activation from RES fob.	Indicates that the RES system was either not registered or not successfully registered to the vehicle using the Subaru Select Monitor tool.
One (1) horn honk/light flash immediately after activation from RES fob. Followed by a pause and then six (6) additional horn honks/light flashes.	Indicates that a vehicle door, trunk or rear gate was open when activating RES. All doors, trunk or rear gate must be closed for RES system to operate. <a href="#">Prevent Remote Engine Start - Door Open - Video Link</a>

## Remote Engine Start Diagnostic Mode

The remote engine start module is equipped with a diagnostic mode that will aid in troubleshooting abnormal failure to start or abnormal shut down conditions. The diagnostic mode saves the last abnormal failure to start or abnormal shut down in memory. This is particularly helpful in determining a past failure when the system may not be currently exhibiting the observed failure mode. Normal shut downs will not be included in the diagnostic table. Normal shutdowns include: run time expiration, shut down or failure to start when a vehicle door is opened and shut down via the RES transmitter.

Accessing diagnostic mode:

1. Enter the vehicle and close all vehicle doors, trunk or rear gate.
2. Verify that the transmission shifter is in the "park" position.
3. Turn the ignition to the "ON" position and leave on for approximately 2 seconds then "OFF", "ON" then "OFF", "ON" then "OFF", "ON" then "OFF", "ON" then "OFF", then back "ON" and leave on throughout the programming process. (Six (6) ignition key cycles ending in "ON", total duration from point of second ignition "ON" cycle must not exceed eight (8) seconds.)

**NOTE: In order to avoid accidentally entering Run Time Selection Mode (see page 22 of this guide), cycle the ignition from OFF to ON six (6) times as quickly as possible.**

4. The system will flash the side marker lights, tail lights, front position lights and honk the horn a number of times corresponding with the below table.

Horn Honks	Shutdown Condition	Diagnosis
No Honk	Normal Operation	Normal remote start operation. No abnormal shut downs have occurred since installation of the system.
1 Honk	Hood Safety Switch Active	Verify that hood is closed and latched. Check for damaged or mis-aligned hood switch/bracket.
2 Honks	Brake Pedal Depressed	Check for damaged or inop brake switch in vehicle or connection issue between BIU and brake pedal switch. This does not indicate failure of an RES component.
3 Honks	RES Stop Request	The vehicle's BIU sent a "stop request" to the RES module to indicate a vehicle related concern (DTC's, etc.). Vehicle condition must be corrected prior to restoring RES operation. This does not indicate failure of an RES component. Contact SOA for a listing of conditions and DTC's that would cause the BIU to transmit an "RES Stop Request" message.
4 Honks	RPM Over-rev	The RES module reads a CAN message to determine engine speed (> 3,500 RPM). Check vehicle systems to determine what would cause an abnormal high RPM. This does not indicate failure of an RES component. <a href="#">Remote Engine Start Shutdown - Overrev Protection - Video Link</a>
5 Honks	Missing CAN Messages	The RES system detected missing CAN Bus messages from the BIU or TCU. Verify proper operation of both BIU and TCU. This does not indicate failure of an RES component.
6 Honks	Shifter Not in Park	This indicates that the shifter was not in park at the time of RES activation or was moved out of park after RES activation. Verify operation of transmission/shifter switches. Verify operation of the BIU and TCU. This does not indicate failure of an RES component. <a href="#">Prevent Remote Engine Start - Shifter Out of Park - Video Link</a>
7 Honks	CAN Error	This fault indicates that the RES module recorded 24 or more CAN error messages. Clear any vehicle DTC's that are present and re-test. If DTC's continue to occur, remove the (2) 10 AMP fuses from the RES main harness. If DTC's return, there is an issue with another vehicle component. If DTC's do not return or return only when RES system is running the vehicle, replace the RES control module (ECU).



## Advanced Troubleshooting

### **The RES system will not run for the full default 15-minute run time.**

The RES system run time is selectable for 3 minutes, 5 minutes, 10 minutes and 15 minutes. Please refer to the vehicle owner's manual, RES quick reference card or page 22 of this guide for RES system run time selection.

### **The RES system will not operate when activated multiple times in a row.**

A safety feature has been added to the RES system to prevent operation for more than 20 minutes in between physical ignition key cycles. Turning the ignition key to the ON/RUN position and then back off will reset the 20 minute timer.

If the 20 minute max duration has been reached in between vehicle ignition key cycles, the vehicle's horn will honk three (3) times on subsequent remote start activations to alert the user that the max operation time has been reached.

## Advanced Troubleshooting

### The RES system shuts down when any vehicle door, trunk or rear gate is opened.

This is an additional safety feature and is normal operation.

Note: The vehicle will continue to run if the trunk is opened on sedan vehicles.

Refer to the Installation Instructions Post Installation Checklist for details.

[Remote Engine Start Shutdown - Door Open - Video Link](#)

### The vehicle starts by itself without pressing the RES transmitter button.

Two conditions could exist that would allow the vehicle to start without user interaction with the RES transmitter.

1. Another user's transmitter was accidentally programmed to the RES system and in range of activation.
2. Damage (usually from a severe drop/shock) to the RES transmitter is causing the button to stay engaged or causing a self transmit.

1. Another user's transmitter accidentally programmed to the system and in range of activation.

To correct this situation, the unauthorized transmitter must be "de-programmed" from the RES system. All customer RES transmitters must be available. Following the transmitter programming procedure on page 22 of this guide, when you reach step 5, you will program each transmitter multiple times to fill all 8 memory slots. For example, if 2 transmitters are available, program each transmitter four (4) times. This will "de-program" or remove any unauthorized transmitter.

- Does this solve the problem?

NO

2. Damage (usually from a severe drop/shock) to the RES transmitter is causing the button to stay engaged or causing a self transmit.

If this issue is the cause of the vehicle starting on its' own, a slight touch or rub of the RES transmitter button would cause it to activate. If this is the case, replace and program the RES transmitter P/N: H001SFL020.

## Advanced Troubleshooting

The SSM IV (DST-i) screen displays “Registration Failure” when attempting to register the RES control module to the vehicle.

- Are the 8-pin and 12-pin connectors at the RES control module secure?
- Are the ignition switch T-connectors properly installed and secure?
- Are the vehicle pre-arrangement connectors secure between the RES control module and pre-arrangement connectors?

NO

Ensure that all wire harness connectors are secure at the RES control module, ignition switch and vehicle pre-arrangement connectors and re-attempt the registration process.

YES

- Verify +12 volt battery power at the 8-pin and 12-pin RES module connectors. Refer to the vehicle-specific System Layout pages of this guide for reference.
- Verify that the 10 amp fuses on the RES wire harness are not blown.
- Verify that no loose or damaged terminals / connectors are present at the RES control module 8-pin and 12-pin connectors, 8-pin male and female ignition connectors or 2-pin, 4-pin or 6-pin pre-arranged connectors as applicable.

NO

Replace any blown fuses in the RES ignition harness as necessary.

If loose or damaged terminals are found at the 8-pin or 12-pin RES module connectors, replace the RES wire harness as necessary.

If loose or damaged terminals are found at the 8-pin male and female ignition connectors or 2-pin, 4-pin or 6-pin pre-arranged connectors, replace the RES wire harness as necessary.

YES

Replace the RES control module/ECU, register the RES control module to the vehicle (page 19-21) and program the RES transmitters to the control module (page 22).

## Advanced Troubleshooting

**CAN Diagnostic Trouble Codes (“U codes”) are triggered in the vehicle.**

- Temporarily remove the 10 amp power fuses from the RES wire harness and unplug the 8-pin and 12-pin RES control module connectors.

- Do the DTC's clear and remain cleared when the vehicle is operated using the ignition key?

NOTE: After verification, re-install the 10 amp fuses and plug the 8-pin and 12-pin connectors back into the RES control module.

NO

This problem is not likely related to the RES system.

YES

- Verify +12 volt battery power at the 8-pin and 12-pin RES module connectors. Refer to the vehicle-specific System Layout pages of this guide for reference.

- Verify +12 volt battery power at the 8-pin male and female ignition connectors.

- Verify that the 10 amp fuses on the RES wire harness are not blown.

- Verify that no loose or damaged terminals / connectors are present at the RES control module 8-pin and 12-pin connectors, 8-pin male and female ignition connectors or 2-pin, 4-pin or 6-pin pre-arranged connectors as applicable.

NO

Replace any blown fuses in the RES ignition harness as necessary.

If loose or damaged terminals are found at the 8-pin or 12-pin RES module connectors, replace the RES wire harness as necessary.

If loose or damaged terminals are found at the 8-pin male and female ignition connectors or 2-pin, 4-pin or 6-pin pre-arranged connectors, replace the RES wire harness as necessary.

YES

Replace the RES control module/ECU, register the RES control module to the vehicle (page 19-21) and program the RES transmitters to the control module (page 22).

## Advanced Troubleshooting

### The vehicle's ignition turns ON when the RES system is activated but it does not crank the starter.

- Was the RES control module successfully programmed to the vehicle using the SSM IV (DST-i)?

NO

Follow the procedures for "Remote Engine Start Control Module Registration" on page 19-21 of this guide to register the RES control module to the vehicle.

YES

Temporarily disconnect the hood safety switch (2017-2018MY Impreza/Crosstrek) or engage the factory hood latch/safety switch and connect a battery charger to the vehicle's battery. Attempt the remote start system again with the battery charger connected.

- Does this solve the problem?

YES

Replace or recharge the vehicle's battery as necessary.

Note: The RES system is required to cease crank output if the vehicle's ignition circuit is registering less than 9.0 volts at RES system power-up. The system will make 3 additional attempts. The system will also abort the RES process (no start re-attempts will occur) if ignition circuit is registering < or equal to 6.0 volts during the starter crank cycle.

Note: Be sure to reconnect the hood safety switch or disengage the factory hood latch after testing.

NO

- Are any CAN diagnostic ("U codes") present in the vehicle?

YES or  
NO

- Verify +12 volt battery power at the 8-pin and 12-pin RES module connectors. Refer to the vehicle-specific System Layout pages of this guide for reference.

- Verify that the 10 amp fuses on the RES wire harness are not blown.

- Verify that no loose or damaged terminals / connectors are present at the RES control module 8-pin and 12-pin connectors, 8-pin male and female ignition connectors or 2-pin, 4-pin or 6-pin pre-arranged connectors as applicable.

NO

Replace any blown fuses in the RES ignition harness as necessary

If loose or damaged terminals are found at the 8-pin or 12-pin RES module connectors, replace the RES wire harness as necessary.

If loose or damaged terminals are found at the 8-pin male and female ignition connectors or 2-pin, 4-pin or 6-pin pre-arranged connectors, replace the RES wire harness as necessary.

YES

Replace the RES control module/ECU, register the RES control module to the vehicle (page 19-21) and program the RES transmitters to the control module (page 22).

- Does this solve the problem?

NO

This problem is not likely related to the RES system.

## Advanced Troubleshooting

The RES system does not turn ON the vehicle's ignition circuits after receiving the remote start command.

- Was the RES control module successfully programmed to the vehicle using the SSM IV (DST-i)?

NO

Follow the procedures for "Remote Engine Start Control Module Registration" on page 19-21 of this guide to register the RES control module to the vehicle.

YES

- Does the vehicle start and operate properly when starting with the ignition key?

NO

- Verify that the remote engine start 8-pin male and female ignition connectors are securely seated.

- Verify that the RES control module 8-pin and 12-pin connectors are securely seated into the remote engine start control module.

- Verify that the 2-pin, 4-pin and 6-pin pre-arranged connectors are securely seated as applicable.

YES

- Verify that there is +12 volt output at the Ignition wire of the RES control module 8-pin connector after the remote engine start system is activated. Refer to the vehicle-specific System Layout pages of this guide for reference.

- Verify that the 10 amp fuses on the RES wire harness are not blown and replace as necessary.

- Does this solve the problem?

NO

Replace the RES control module/ECU, register the RES control module to the vehicle (page 19-21) and program the RES transmitters to the control module (page 22).

## Advanced Troubleshooting

### The vehicle starts when the RES system is activated, but the heater / air conditioning does not turn ON.

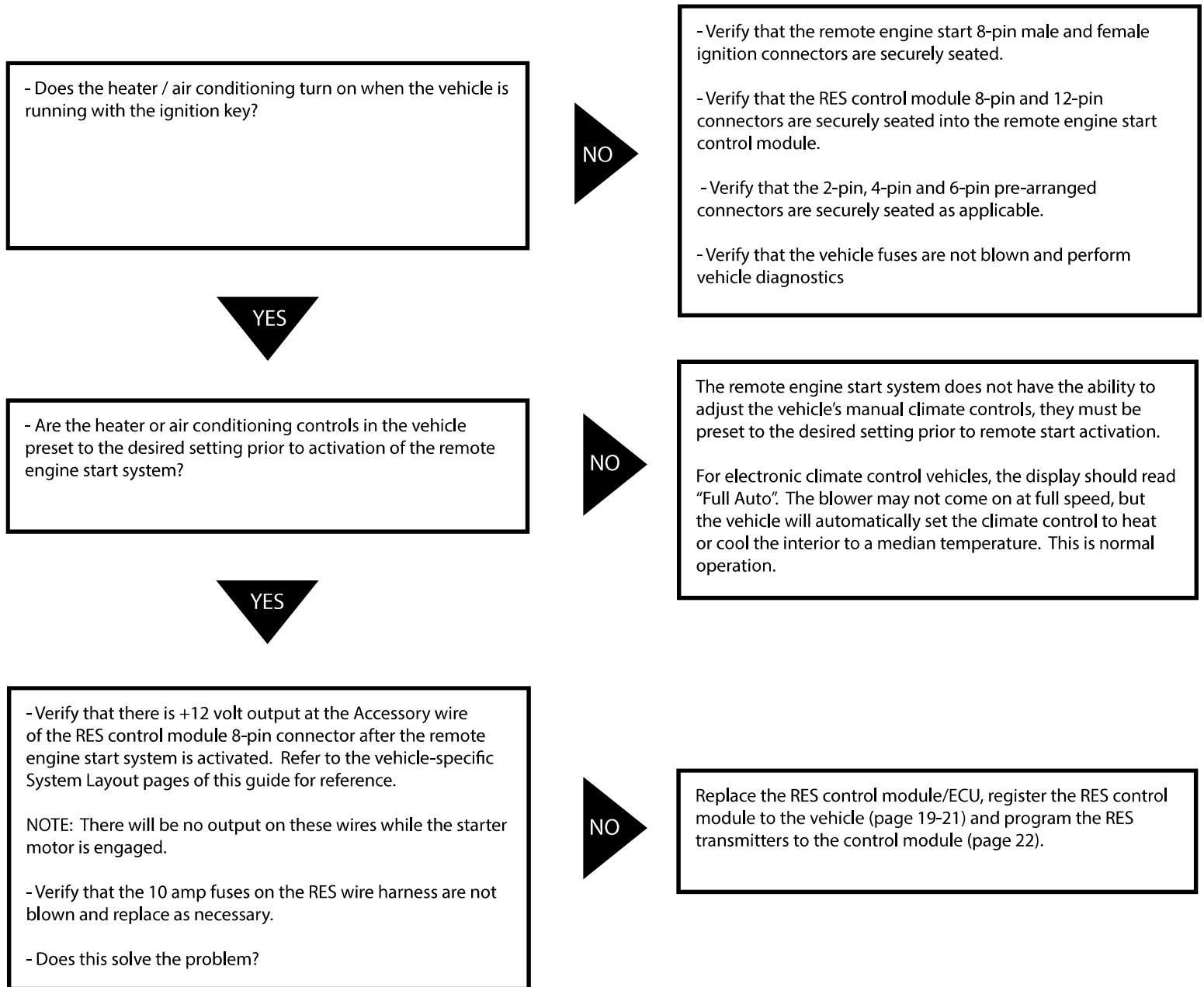

## Advanced Troubleshooting

The RES system does not respond when the RES transmitter button is pressed 2-times.

- Do the blue LEDs flash when the RES transmitter START buttons are pressed?

- Do the RES transmitter batteries have sufficient charge?

Note: The 3 volt lithium battery should register a 3 volt charge while tested under load. Battery life under normal usage is approximately 1 year.

Note: The operating range of the RES system is up to 400'.

NO

Refer to the vehicle owner's manual remote start section for battery replacement (Battery CR2450).

YES

- Do both transmitters fail to function when and an activation attempt is made?

NO

Using the "Remote Engine Start Bi-directional Transmitter Programming Procedure" on page 22 of this guide, attempt to reprogram the RES transmitter.

- Does this solve the problem?

YES

NO

Using the "Remote Engine Start Bi-directional Transmitter Programming Procedure" on page 22 of this guide, attempt to reprogram the RES transmitters.

- Does this solve the problem?

NO

Replace the RES transmitter(s) (P/N: H001SFL020) and program the RES transmitter(s).

- Does this solve the problem?

NO

Replace the RES control module/ECU, register the RES control module to the vehicle (page 19-21) and program the RES transmitters to the control module (page 22).



### The RES system bi-directional feature does not function.

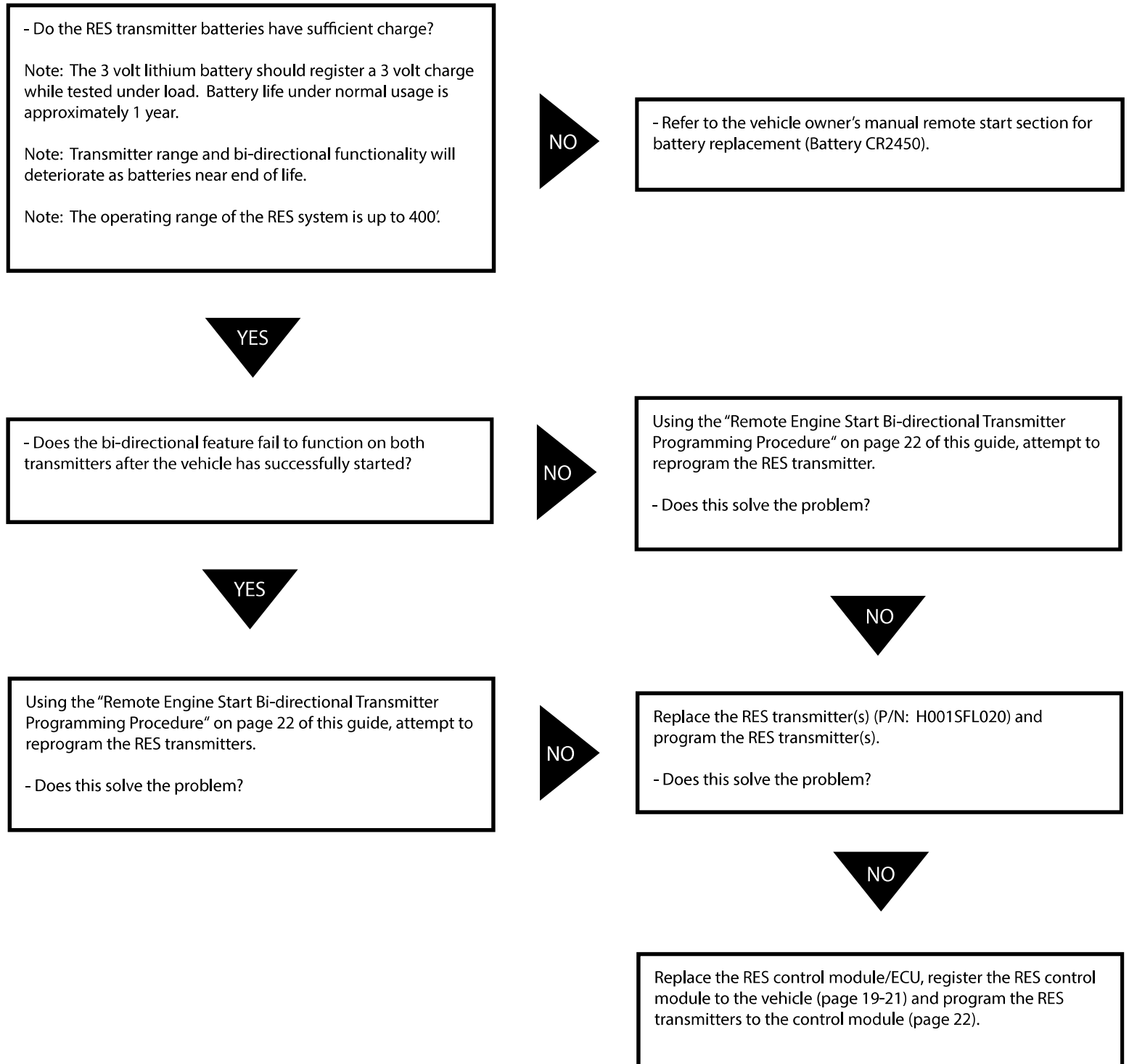

## Advanced Troubleshooting

The vehicle's ignition turns ON and the honk honks two (2) times when activating the RES system.

The remote engine start system is detecting one of the following safety shutdown inputs. This must be corrected prior to restoring normal remote start functionality.

1. Hood Open
2. Brake Pedal Depressed
3. Ignition key sense circuit active (key in ignition cylinder)
4. Transmission Shifter Not in Park

Hood Open

NO

Verify that the hood safety switch/bracket are properly installed or the factory hood latch switch is working properly. Check for damage or misalignment of the hood switch/bracket.

The White wire (Impreza/Crosstrek) (pin 10) of the 12-pin RES control module connector should register ground when the hood is open and register open when the hood is closed.

Brake Pedal Depressed

NO

Check for damaged or inoperable brake switch in the vehicle or connection issue between BIU and brake pedal switch.

The RES control module reads this input from the hood switch (Impreza/Crosstrek) or through a CAN Bus message and is likely a vehicle related issue rather than a remote start component failure.

Ignition Key Sense Circuit Active

NO

Verify that no ignition key is resting in the ignition cylinder.

Check for a damaged or inoperable key sense switch in the vehicle or connection issue between BIU and key sense switch. The RES module reads this input through a CAN Bus message and is likely a vehicle related issue rather than a remote start component failure.

Transmission Shifter Not in Park

NO

Verify that the transmission shifter is not in gear.

Check for damaged or inoperable shift position switch in the vehicle or a connection issue between the TCU or BCM and shift position switch. The RES module reads this input through a CAN Bus message and is likely a vehicle related issue rather than a remote start component failure.

## Advanced Troubleshooting Video Links

Subaru Remote Engine Start Troubleshooting Videos			
Video #	Video Link	Vehicle Response (# of Horn Honks)	Description
1	<a href="#">Remote Engine Start Shutdown - Door Open</a>	One (1) Horn Honk for RES Activation NO Horn Honks for RES Shut Down	Reasons for RES Shutdown - Any Door Open
2	<a href="#">Remote Engine Start Shutdown - Overrev Protection</a>	One (1) Horn Honk for RES Activation NO Horn Honks for RES Shut Down	Reasons for RES Shutdown - RPMs > ~3,500
3	<a href="#">Prevent Remote Engine Start - Brake Switch</a>	Two (2) Horn Honks	Reasons to Prevent RES - Brake Pedal Depressed / Switch Active
4	<a href="#">Prevent Remote Engine Start - Door Open</a>	Six (6) Horn Honks	Reasons to Prevent RES - Any Door Open
5	<a href="#">Prevent Remote Engine Start - Hood Switch</a>	Two (2) Horn Honks	Reasons to Prevent RES - Hood Open / Switch Active
6	<a href="#">Prevent Remote Engine Start - Key In Ignition</a>	Ignition Turns "ON" Two (2) Horn Honks	Reasons to Prevent RES - Key in Ignition Switch
7	<a href="#">Prevent Remote Engine Start - Shifter Out of Park</a>	Ignition Turns "ON" Two (2) Horn Honks	Reasons to Prevent RES - Gear Selector / Shifter out of Park
8	<a href="#">Subaru RES Selectable Run Time Programming</a>	Four (4) Horn Honks to access Selectable Run Time Programming	RES Programming - Selectable Run Time - 3, 5, 10 or 15 (Default) Minutes
9	<a href="#">Subaru RES Transmitter Programming</a>	Three (3) Horn Honks to access RES Transmitter Programming	RES Programming - Transmitter Learn Mode (Stores up to 8 Fobs)