

Field campaign

Topic	V8 Kovomo - Bentayga - Valve spring replacement (SC21/42)
Market area	Russische Föderation (5RU),Australia E04 Bentley rest Asia and Australia (6E04),China 796 VW Import Comp. Ltd (Vico), Beijing (6796),Germany E02 Bentley rest Europe (6E02),Japan E03 Bentley Japan (6E03),Korea, (South) E08 Bentley South Korea (6E08),United Arab Emirates E06 Bentley Middle East and Africa (6E06),United States E05 Bentley USA and rest America (6E05)
Brand	Bentley
Transaction No.	2065480/5
Campaign number	EC25
Note	
Type	
US code	

Vehicle data

Bentayga

Sales types

Type	MY	Brand	Designation	Engine code	Gearbox code	Final drive code
4V14D9	2021	E		*	*	*
4V14D9	2022	E		*	*	*

Chas is numbers

Manufacturer	Filler	Type	Filler	MY	Factory	From	To	Prod from	Prod to
SJA	*	*	*	*	C	038424	039999		
SJA	*	*	*	N	C	011001	011069		

Documents

Document name
master.xml
636install1-15.pdf
636removal1-16.pdf
hydraulicliftingtable636.pdf
sc2142vinlist.pdf

Notes

▪ Repair instructions

Technical background

The intake valve springs (16) and outlet valve springs (16) located within the cylinder heads of Bank 1 and 2 require replacing
The replacement of all valve springs is required due to an issue which was discovered during a routine quality inspection

▪
VERY IMPORTANT: Before continuing with the onward instructions the operative should confirm if the symptoms within TPI 2064776/- are applicable

In the event the symptoms are applicable the operative MUST first conduct TPI 2064776/- to completion

The operative MUST then raise a new Technical DISS query or respond via the already open DISS query and await feedback from Product Support before conducting any further work as further information will be requested back which may change the method of repair

NOTE: The operative should raise a non-technical DISS query before commencing the rework operation within the Work section stating that (SC21/42) is being conducted on the applicable VIN

Revision history

▪
NOTE: All previous issues of this document should be disregarded. Only the latest document (VIN applicable within Elsa Pro) must be used

New revision number:	Type of change:
2065480/3	<i>Incorrect part number - The parts set should have been 36A198115E and not 3SA198115E</i>
2065480/4	<i>Updated to reference the V8 Misfire TPI 2064776/- with new instructions added as the process is now different to that published in Elsa Pro</i>
2065480/5	See bullet points below

- The Genuine parts section has been updated advising 04E998907A or 06M998907 (Repair kit for valve unit) should be used
- The Work section has been updated to include the search location of the valve spring replacement best practice videos (all cylinders) the videos should be accessed via the eAcademy Technical catalogue
- Instructions regarding the replacement of the valve springs (Valve springs - To remove and fit) can be found within the attached documents, the operative MUST read through each attachment prior to starting the rework procedure

Remedy

The replacement of all intake valve springs and all outlet valve springs (Bank 1 and Bank 2) is required

▪
IMPORTANT: The removal and installation instructions are attached to this document, the operative MUST ensure the instructions are followed in numerical order as detailed within the work section

The repair manual is also referred to and MUST be followed when instructed

NOTE: The Work section also contains task applicable instructions which MUST also be referred to/conducted. The instructions can change without warning, the operative must always ensure the latest version of this document and the attached instructions are referred to (Use the applicable VIN in Elsa pro to ensure latest version is referred to)

TIP: The removal and installation procedures have been devised specifically for this procedure, all procedures MUST be strictly adhered to

Customer notification

The procedure must be carried out in conjunction with the PDI process

Warranty accounting instructions

Replacement of the intake and outlet valve springs

Warranty type 790

Damage service number EC25

Damage code 00 66

Criteria 01

Labour

Labour Operation Code 15 65 56 20

Time 2100 TU

Alignment of applicable driver assist systems (Depending on vehicle specification)

NOTE: Please also refer to the information within the Work section (step 3) for further clarification

- Vehicle front + rear measured wheel alignment checked - 44 95 03 00 -110 TU
- Rear wheel camber adjust - 44 94 15 50 - 30 TU
- Rear wheel track adjust - 44 93 15 50 - 30 TU
- Front wheel camber adjust - 44 89 15 50 - 40 TU
- Front wheel track adjust - 44 88 15 50 - 20 TU
- (ACC)-Radar sensor checked + adjusted - 91 63 05 51 - 120 TU
- Overhead view camera adjusted - 90 83 15 00 - 40 TU
- Driver assist camera adjusted - 96 38 15 50 - 120 TU
- Control unit for (Lane change assist) adjusted - 96 35 15 00 - 50 TU
- Night vision system calibration - 90 80 15 50 - 40 TU
- Headlamps to adjust - 94 15 16 00 (as per Labour operations)
- ODIS Time - 01 50 00 00 (Time as per ODIS log)

Genuine parts

Part number	Description	Quantity
06E109623AD	Intake valve springs	16
0P2109623	Outlet valve springs	16
36A198115E	Parts set	1
0P2103484	Seal	1
0P2103517	Seal	1
G052565A1	Silicone paste	As required
N10458202	Hexagon bolt M6x22	4
WHT007821	O-ring 31x2	2
WHT008638	O-Ring 17.5x1.5	8
04E998907A or 06M998907	Repair kit for valve unit	8
D176501A1	Loctite 5970- BM (Source locally)	As required
04E906145	Seal ring	4
06M145113	Seal	1
034115427B	O-Ring 12x2	1
0P2103650E	Gasket for cover Cylinders 1-4	1
0P2103649E	Gasket for cover Cylinders 5-8	1
0P2103113A	Cover	3
06M109235	Seal	4

06M109493D	Plate	4
0P2129056	Seal	2
N90344501	O-Ring 45x3	2
N91019101	O-Ring 50x3	2
99970751741	O-Ring 22x3	2
N90365304	O-Ring 20x3	1
N90925001	O-Ring 17x3	3
8W0253115	Turbo to pre catalytic seal	2
8W0253725D	Clamp for turbochargers	2
8W0253115D	Downpipe to pre catalytic seal	2
N91130802	Downpipe to catalytic nut	6
Refer to ETKA and Rep.Gr 00 (Power transmission fluids and capacities)	Differential oil (front and centre)	As required
Refer to ETKA and Rep.Gr 00 (Power transmission fluids and capacities)	Transmission fluid	As required
Refer to ETKA and Rep.Gr 00 (Engine fluids and capacities)	Engine coolant	As required
00004320935	Microgleit DF977S (Source locally)	As required
00004320993	Loctite 7515 primer (Source locally)	As required

Parts supply

All parts listed within this document are currently restricted and will follow a specific process to minimise disruption for Retailers and ensure delivery is received in complete vehicle sets.

Please do not raise any unnecessary part orders or service calls.

Parts despatch control

The parts will be controlled centrally and automatically allocated and distributed therefore in this case there is no requirement for retailers to place orders

Repair instructions

• **Notes**

Technical background

The intake valve springs (16) and outlet valve springs (16) located within the cylinder heads of Bank 1 and 2 require replacing

The replacement of all valve springs is required due to an issue which was discovered during a routine quality inspection

VERY IMPORTANT: Before continuing with the onward instructions the operative should confirm if the symptoms within TPI 2064776/- are applicable

In the event the symptoms are applicable the operative MUST first conduct TPI 2064776/- to completion

The operative MUST then raise a new Technical DISS query or respond via the already open DISS query and await feedback from Product Support before conducting any further work as further information will be requested back which may change the method of repair

NOTE: The operative should raise a non-technical DISS query before commencing the rework operation within the Work section stating that (SC21/42) is being conducted on the applicable VIN

Revision history

NOTE: All previous issues of this document should be disregarded. Only the latest document (VIN applicable within Elsa Pro) must be used

New revision number:	Type of change:
2065480/3	<i>Incorrect part number - The parts set should have been 36A198115E and not 3SA198115E</i>
2065480/4	<i>Updated to reference the V8 Misfire TPI 2064776/- with new instructions added as the process is now different to that published in Elsa Pro</i>
2065480/5	See bullet points below

- The Genuine parts section has been updated advising 04E998907A or 06M998907 (Repair kit for valve unit) should be used
- The Work section has been updated to include the search location of the valve spring replacement best practice videos (all cylinders) the videos should be accessed via the eAcademy Technical catalogue
- Instructions regarding the replacement of the valve springs (Valve springs - To remove and fit) can be found within the attached documents, the operative MUST read through each attachment prior to starting the rework procedure

Check

If the vehicle is not already listed as repaired in the "Repair history" (in Elsa Pro) refer to the Identification section to check the presence of the green paint completion mark (Figure 6)

Should neither be evident ("Repair history" or applicable paint mark) carry out the required work in accordance with these instructions

Genuine parts

Part number	Description	Quantity
06E109623AD	Intake valve springs	16
0P2109623	Outlet valve springs	16
36A198115E	Parts set	1
0P2103484	Seal	1
0P2103517	Seal	1
G052565A1	Silicone paste	As required
N10458202	Hexagon bolt M6x22	4
WHT007821	O-ring 31x2	2
WHT008638	O-Ring 17.5x1.5	8
04E998907A or 06M998907	Repair kit for valve unit	8
D176501A1	Loctite 5970- BM (Source locally)	As required
04E906145	Seal ring	4
06M145113	Seal	1
034115427B	O-Ring 12x2	1
0P2103650E	Gasket for cover Cylinders 1-4	1
0P2103649E	Gasket for cover Cylinders 5-8	1
0P2103113A	Cover	3
06M109235	Seal	4
06M109493D	Plate	4
0P2129056	Seal	2
N90344501	O-Ring 45x3	2
N91019101	O-Ring 50x3	2
99970751741	O-Ring 22x3	2

N90365304	O-Ring 20x3	1
N90925001	O-Ring 17x3	3
8W0253115	Turbo to pre catalytic seal	2
8W0253725D	Clamp for turbochargers	2
8W0253115D	Downpipe to pre catalytic seal	2
N91130802	Downpipe to catalytic nut	6
Refer to ETKA and Rep.Gr 00 (Power transmission fluids and capacities)	Differential oil (front and centre)	As required
Refer to ETKA and Rep.Gr 00 (Power transmission fluids and capacities)	Transmission fluid	As required
Refer to ETKA and Rep.Gr 00 (Engine fluids and capacities)	Engine coolant	As required
00004320935	Microleite DF977S (Source locally)	As required
00004320993	Loctite 7515 primer (Source locally)	As required

Tools

Refer to the attached instructions for all tooling requirements

Work

VERY IMPORANT: The operative must ensure the attached rework instructions are read and understood prior to starting the rework

TIP: When replacing the valve springs the operative should refer to the valve spring replacement videos

Please see the information to locate the Videos:

- Log on to GRP: <https://grp.volkswagenag.com/>
- Select "eAcademy"
- Select "MyLearning", then "Browse a Catalogue"
- Select "Technical", then select page 7

Or

- Select "MyLearning", then "Search"
- Search "EA825" and the videos will be listed

Refer to Figure 1

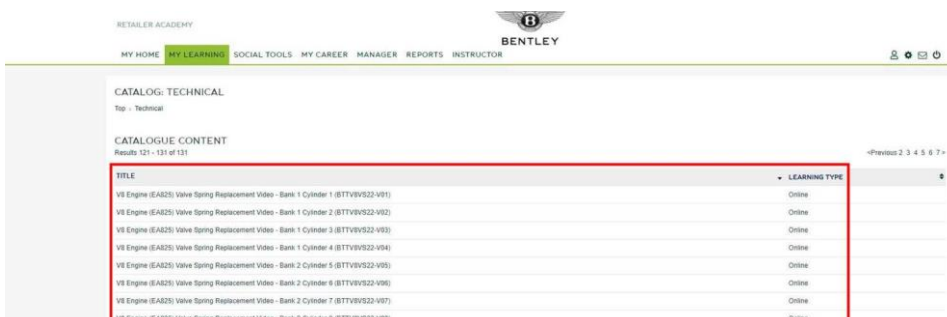

Figure 1

1) Referring to Rep.Gr 10 - Remove the engine and transmission

IMPORTANT: Ensure the engine and transmission is suitably secured to the hydraulic lifting table and ensure the attached hydraulic lifting table instructions are followed

NOTE: Once the engine is removed there is not a requirement to separate the transmission from the engine, the replacement

of the valve springs should be conducted with the engine and transmission sitting on the hydraulic lifting table

2) Referring to Rep.Gr 26 - Remove both catalytic converters and associated heatshields

3) It is imperative the attached instructions are followed in numerical order (as below), as each task has been individually generated to allow the operative to conduct the rework with minimal disruption

Removal

1 - High-pressure fuel line

2 - Upper chain housing covers

3 - Oil mist separators

4 - Ignition coils

5 - High pressure fuel lines, banks 1 and 2

6 - High pressure fuel pumps

7 - Fuel rails

8 - CDA solenoids

9 - Fuel injectors

10 - Mechanical vacuum pump

11 - Pressure pipes

12 - Camshaft actuators

13 - Cylinder head cover

14 - Valve lifters (hydraulic tappets) 15

- Spark plugs

16 - Valve springs - To remove and fit

NOTE: It is imperative the attached instructions are followed in numerical order as each task has been individually generated to allow the operative to conduct the rework with minimal disruption

VERY IMPORTANT: The operative MUST ensure the valve springs are fitted in the correct location as the part numbers of the Intake valves and Outlet valves are different.

TIP: To ensure consistency/accuracy during the replacement of the valve spring process and to ensure the springs are fitted in the correct location, it is highly recommended the same operative is used for the duration of this process

- 06E 109 623AD - Intake valve springs - Figure 2 (Located on the outside edge of each bank)

HINT: Referring to Figure 2 - The valve spring is shown in the orientation as it should be fitted IMPORTANT: The 3 white lines shown/circled on the upper face of the spring must be facing upwards when fitted



Figure 2

- 0P2 109 623 - Outlet valve springs - Figure 3 (Located on the inside edge of each bank)

HINT: Referring to Figure 3 - The valve spring is shown in the orientation as it should be fitted IMPORTANT: The 4 blue lines shown/circled on the upper face of the spring must be facing upwards when fitted



Figure 3

TIP: When removing the original parts it is best practice to keep the new parts completely separate to eliminate cross contamination

HINT: Ensure all parts which are not required to be replaced (as part of this process) are inspected prior to refitting and replaced if required

VERY IMPORTANT: When replacing the valve springs (once the collets and valve spring cap is removed from each valve) it is imperative that constant air pressure is supplied to the affected cylinder whilst the replacement of the valve springs is being conducted, in the event the air supply is lost or is not maintained during this operation the applicable valve could drop directly in the cylinder resulting in the possible requirement to remove the cylinder head to retrieve the valve

4) To complete the installation of the valve springs - Refer to the attached installation instructions in numerical order (as below)

VERY IMPORTANT: The operative MUST ensure the valve springs are fitted in the correct location as the part numbers of the Intake valves and Outlet valves are different.

TIP: To ensure consistency/accuracy during the replacement of the valve spring process and to ensure the springs are fitted in the correct location, it is highly recommended the same operative is used for the duration of this process

INSTALLATION

- 1 - Spark plugs
 - 2 - Valve lifters (hydraulic tappets)
 - 3 - Cylinder head covers
 - 4 - Camshaft actuators (includes setting timing)
 - 5 - Pressure pipes
 - 6 - Mechanical vacuum pump
 - 7 - Fuel injectors
 - 8 - CDA solenoids
 - 9 - Fuel rails
 - 10 - High pressure fuel pumps
 - 11 - High pressure fuel lines, banks 1 and 2
 - 12 - Ignition coils
 - 13 - Oil mist separators
 - 14 - Upper chain housing covers
 - 15 - High pressure fuel line
- 5) Referring to Rep. Gr 26 - Refit both catalytic converters and associated heatshields
- 6) Referring to Rep. Gr 10 - Refit the engine and transmission
- 7) Carry out wheel alignment and ensure the driver assist system calibrations are performed as described in the onward instructions (Depending on vehicle specification)

- Check the alignment of the front + rear wheel alignment

NOTE: The requirement to adjust the front and rear wheel alignment should only be carried out if alignment is shown to be out of specification

Please ensure a screenshot of the before and after measurements are attached to a new or existing non-technical DISS query

- Rear wheel camber adjust (see previous note)
- Rear wheel track adjust (see previous note)

- Front wheel camber adjust (see previous note)
- Front wheel track adjust (see previous note)
- (ACC) - Radar sensor checked + adjusted

NOTE: The following require recalibration/adjustment in the event the front and rear wheel alignment was found to be out of specification and adjusted

- Overhead view camera adjusted
- Control unit for (Lane change assist) adjusted
- Night vision system calibration

NOTE: The Driver assist camera recalibration/adjustment is MANDATORY and MUST BE conducted regardless

NOTE: The headlamps only require adjustment if headlamp/fender is removed/damaged

8) Raise a non-technical DISS query attaching the following

- Before and after screen shots of the wheel alignment results
- Screen shots confirming the applicable drive assist systems have been successfully adjusted/calibrated

Warranty payments will not be approved without the submission of the requested results via the open DISS query

9) Conduct the PDI road test - On return confirm that no DTC's are evident

Please ensure the Park brake is applied and the transmission is in the "NEUTRAL" position (not "Park" position)

VERY IMPORTANT: For Bentayga S models in North America, China and South Korea only

- The operative must follow Step 10 to completion before proceeding directly to Step 12

For all other Bentayga models in North America, China and South Korea only (Not Bentayga S) the operative must follow step 11 to completion before proceeding to Step 12

VERY IMPORTANT: For all Regions and all Bentayga models including Bentayga S (Not Bentayga S in North America, China and South Korea only)

- The operative must follow Step 11 to completion before proceeding directly to Step 12

10) **Bentayga S models (North America, China and South Korea only)**

- VERY IMPORTANT: Check and confirm that no DTC's are evident

Or

No engine operation issues are evident - Save an online log to confirm that no DTC's were evident at this stage of the procedure

VERY IMPORTANT: Please ensure that no ignition cycles, Deletion of DTC's or any other tests are run in between the following steps as this will set the readiness code and prevent unrelated DTC's from being evident

- Run the engine basic setting routine - Select option 3.7 - Test for oxygen sensor interchange after catalytic converter
- Immediately run the Readiness test as per the following instructions:
- Referring to Figure 4
- Select Guided functions from 01 – Engine Control Module 1
- Select Generate readiness code
- Select Execute

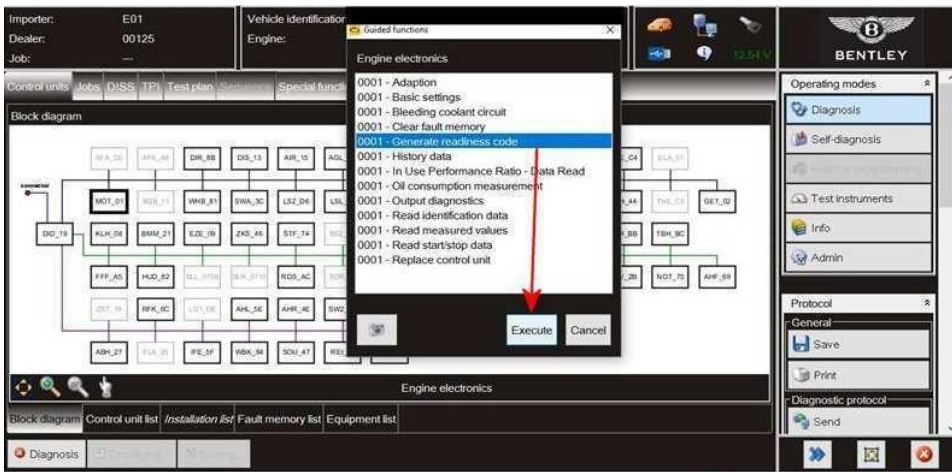

Figure 4

Please be aware that not all readiness bytes may be at zero, however this is not a requirement as the remaining bytes will set during normal customer driving cycle routines

11) For all Regions and all Bentleyga models including Bentleyga S (Not Bentleyga S in North America, China and South Korea)

Check and confirm that no DTC's are stored or there are no engine operation issues evident - Save an online log to confirm that no DTC's were evident at this stage of the procedure

- Referring to Figure 5
- Select Guided functions from 01 – Engine Control Module 1
- Select Generate readiness code
- Select Execute

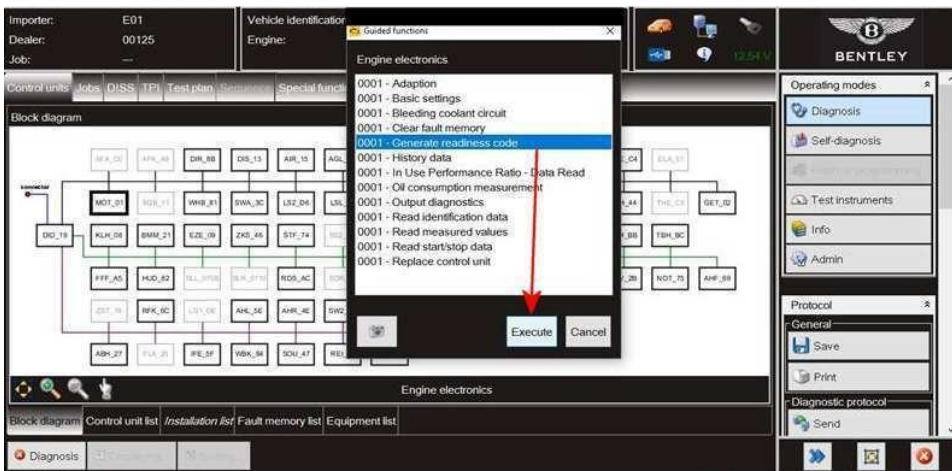

Figure 5

Please be aware that not all readiness bytes may be at zero, however this is not a requirement as the remaining bytes will set during normal customer driving cycle routines

- 12) Confirm no oil/fluid leaks are evident
- 13) Place a green paint completion mark as shown within the Identification section (Figure 6)

Identification

Green paint completion mark on the 12 volt battery vent hose (Figure 6)

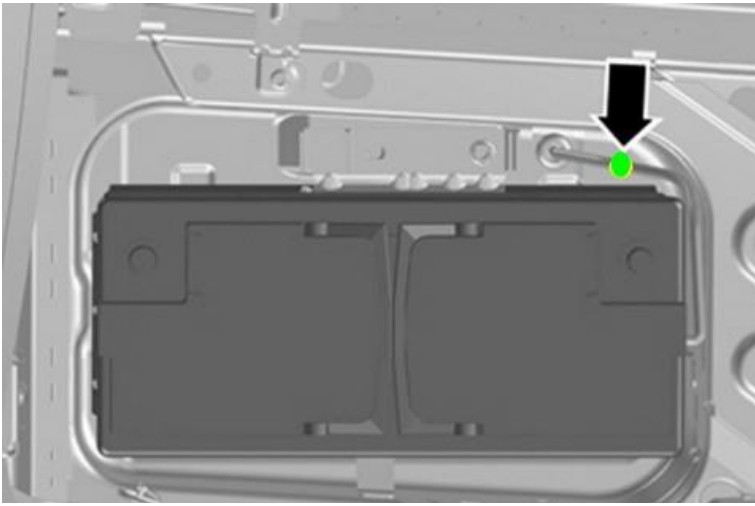

Figure 6

▪ [Repair instructions](#) ▪ [Notes](#)

SJAAL14V2MC038424	SJAAL14V8MC039335	SJAAL14V7MC039486	SJAAM2ZVXNC039611
SJAAL34VXMC038506	SJAAL1ZV1MC039346	SJAAD14V4MC039488	SJAAM14VXNC039612
SJAAL14VXMC038543	SJAAD14V8MC039347	SJAAL14V0MC039491	SJAAM2ZV5NC039614
SJAAM2ZV7MC038544	SJAAM2ZV1MC039348	SJAAD14V8MC039493	SJAAL14V1NC039615
SJAAL14VXMC038591	SJAAL14V4MC039350	SJAAL14V1MC039497	SJAAM2ZV0NC039617
SJAAD14V0MC038595	SJAAD14V5MC039354	SJAAD14V9MC039504	SJAAM2ZV4NC039619
SJAAL14V4MC038635	SJAAM2ZV4MC039361	SJAAD14V0MC039505	SJAAM2ZV2NC039621
SJAAD14V1MC038637	SJAAD14V4MC039362	SJAAL1ZV8MC039506	SJAAM2ZV6NC039623
SJAA514V5MC038640	SJAAD14V8MC039364	SJAAM2ZVXMC039509	SJAAM2ZV3NC039627
SJAAL14V1MC038690	SJAAL1ZV7MC039366	SJAAM2ZV6MC039510	SJAAM14V3NC039628
SJAAB14V3MC038709	SJAAL1ZV0MC039371	SJAAD14V1MC039514	SJAAM2ZV3NC039630
SJAAB14V9MC038715	SJAAD14V0MC039374	SJAAM2ZV5MC039515	SJAAM2ZV5NC039631
SJAAL14V9MC038727	SJAAL14V9MC039375	SJAAL1ZV0MC039516	SJAAM2ZV7NC039632
SJAAL1ZV6MC038743	SJAAM2ZV1MC039379	SJAAD14V0MC039519	SJAAM2ZV2NC039635
SJAAL1ZV2MC038772	SJAAM2ZV5MC039384	SJAAL1ZV2MC039520	SJAAM14V2NC039636
SJAAD14V0MC038791	SJAAM2ZV0MC039387	SJAAL1ZV5MC039527	SJAAM2ZV8NC039641
SJAAL14V8MC038797	SJAAM2ZV2MC039388	SJAAD14V3MC039529	SJAAM2ZVXNC039642
SJAAL14V8MC038833	SJAAD14V0MC039391	SJAAD14V1MC039531	SJAAM2ZV3NC039644
SJAAL14V8MC038850	SJAAD14V4MC039393	SJAAD14V5MC039533	SJAAM14V3NC039645
SJAAL14V0MC038860	SJAAL14V4MC039400	SJAAD14V9MC039535	SJAAM2ZV7NC039646
SJAAL14VXMC038865	SJAAM2ZV1MC039401	SJAAD14V2MC039537	SJAAM2ZV9NC039647
SJAAD14V5MC038866	SJAAD14V3MC039403	SJAAD14V4MC039538	SJAA514V2NC039648
SJAAL14V1MC038897	SJAAD14V5MC039404	SJAAD14V6MC039539	SJAAM2ZV9NC039650
SJAAD14V5MC038916	SJAAL14V3MC039405	SJAAL14V9MC039540	SJAAM14V6NC039655
SJAAD14V7MC038920	SJAAD14V0MC039407	SJAAL14V0MC039541	SJAAM2ZVXNC039656
SJAAL14V7MC038922	SJAAL14V9MC039408	SJAAL14V6MC039544	SJAAM2ZV3NC039658
SJAAL14V5MC038949	SJAAL14V9MC039411	SJAAD14V5MC039547	SJAAM2ZV3NC039661
SJAAL14V6MC038958	SJAAM2ZV6MC039412	SJAAD14V7MC039548	SJAAM14V9NC039665
SJAAL34V3MC038962	SJAAD14VXMC039415	SJAAD14V8MC039557	SJAAM2ZV4NC039667
SJAAB14V7MC038969	SJAAM2ZV7MC039418	SJAAD14VXMC039558	SJAAM2ZV6NC039668
SJAAL14V6MC038975	SJAAM2ZV7MC039421	SJAAM2ZV3MC039559	SJAAM2ZV8NC039669
SJAAD14V3MC038977	SJAAD14V0MC039424	SJAAM2ZVXMC039560	SJAAM2ZV6NC039671
SJAAL14V5MC038983	SJAAD14V4MC039426	SJAAD14VXMC039561	SJAAM2ZV8NC039672
SJAAL14V4MC039090	SJAAL34V8MC039427	SJAAM2ZV9NC039566	SJAAM2ZVXNC039673
SJAAD14V9MC039129	SJAAD14VXMC039432	SJAAM14V9NC039570	SJAAM2ZV1NC039674
SJAAL14V5MC039132	SJAAD14V5MC039435	SJAA514V4NC039571	SJAAM2ZV7NC039677
SJAAL14V9MC039134	SJAAD14V7MC039436	SJAAM2ZV6NC039573	SJAAM2ZV9NC039678
SJAAL1ZV7MC039142	SJAAM2ZV2MC039438	SJAAL14V2NC039574	SJAAM2ZV7NC039680
SJAAL14V2MC039153	SJAAD14V2MC039439	SJAAM2ZVXNC039575	SJAAM2ZV0NC039682
SJAAB14V2MC039155	SJAAM2ZV0NC039441	SJAAM2ZV1NC039576	SJAAM2ZV6NC039685
SJAAL14V8MC039156	SJAAD14VXMC039446	SJAAM2ZV3NC039580	SJAAL14V4NC039690
SJAAD14V6MC039184	SJAAL14VXMC039448	SJAAM2ZV5NC039581	SJAAM2ZV3NC039692
SJAAL14V6MC039186	SJAAD14V5MC039449	SJAAM2ZV9NC039583	SJAAM2ZV5NC039693
SJAAM2ZV4MC039196	SJAAL14VXMC039451	SJAAM2ZVXNC039589	SJAAM14V5NC039694
SJAAD14V3MC039210	SJAAD14V7MC039453	SJAAM2ZV6NC039590	SJAAM2ZV9NC039695
SJAAL14V5MC039213	SJAAL14V5MC039454	SJAAM14V6NC039591	SJAAM2ZV4NC039698
SJAAM2ZV1MC039298	SJAAD14V6MC039458	SJAAM2ZV1NC039593	SJAAM2ZV0NC039701
SJAAD14V1MC039299	SJAAD14VXMC039463	SJAAM2ZV7NC039596	SJAAM2ZV4NC039703
SJAAD14V6MC039301	SJAAM2ZV3MC039464	SJAAM2ZV9NC039597	SJAAM2ZV6NC039704
SJAAM2ZV0MC039308	SJAAL1ZV4MC039471	SJAAM2ZV0NC039598	SJAAM2ZV3NC039708
SJAAD14V0MC039312	SJAAD14V0MC039472	SJAAM2ZV2NC039599	SJAAM2ZV1NC039710
SJAAD14V4MC039314	SJAAD14V2MC039473	SJAAM2ZV0NC039603	SJAAL14V8NC039711
SJAAL14VXMC039319	SJAAL1ZV1MC039475	SJAAM14V2NC039605	SJAAM2ZV5NC039712
SJAAL14VXMC039322	SJAAL1ZV9MC039479	SJAAM2ZV8NC039607	SJAAL14V2NC039722
SJAAL14V7MC039326	SJAAL14V1MC039483	SJAAM2ZVXNC039608	SJAA514V7NC039726
SJAAL14V0MC039328	SJAAD14V7MC039484	SJAAM2ZV1NC039609	SJAAM2ZV7NC039727
SJAAL14V2MC039329	SJAAL14V5MC039485	SJAAM2ZV8NC039610	SJAAM2ZV0NC039729

SJAAM2ZV7NC039730	SJAAM2ZV5NC039838	SJAAM2ZV0NC039911	SJAAM2ZV5NC039967
SJAAD14V6NC039736	SJAAM2ZV3NC039840	SJAAD14V2NC039913	SJAAD14V5NC039968
SJAAM2ZV3NC039739	SJAAM2ZV5NC039841	SJAAM2ZVXNC039916	SJAAM2ZV9NC039969
SJAAL14V4NC039740	SJAAM2ZV7NC039842	SJAAM2ZV1NC039917	SJAAM2ZV8NC039977
SJAAM2ZV3NC039742	SJAAM2ZV2NC039845	SJAAM2ZV3NC039918	SJAAM2ZVXNC039978
SJAAM2ZV9NC039745	SJAAM2ZV6NC039847	SJAAM2ZV5NC039919	SJAA514V5NC039983
SJAAD14V2NC039748	SJAAM2ZV8NC039848	SJAAM2ZV1NC039920	SJAAM2ZV5NC039984
SJAAM2ZV1NC039755	SJAAM2ZVXNC039849	SJAAM2ZV3NC039921	SJAAM2ZV7NC039985
SJAAM2ZV5NC039760	SJAAM2ZV6NC039850	SJAAM2ZV9NC039924	SJAAM2ZV9NC039986
SJAAD14V0NC039764	SJAAM2ZV8NC039851	SJAAM2ZV0NC039925	SJAAM2ZV0NC039987
SJAA514V8NC039766	SJAAM2ZVXNC039852	SJAAM2ZV2NC039926	SJAAM2ZV4NC039989
SJAAD14V8NC039768	SJAAM2ZV1NC039853	SJAAD14V2NC039927	SJAAM2ZV0NC039990
SJAAM2ZV1NC039769	SJAAM2ZV3NC039854	SJAAM2ZV6NC039928	SJAAM2ZV1NC039996
SJAAL14V5NC039777	SJAAD14V3NC039855	SJAAM2ZV8NC039929	SJAAM2ZV3NC039997
SJAAM2ZV2NC039778	SJAAM2ZV7NC039856	SJAAM2ZV4NC039930	SJAAM2ZV5NC039998
SJAAM2ZV4NC039779	SJAAM2ZV2NC039859	SJAAM2ZV6NC039931	SJAAM2ZV7NC039999
SJAAM2ZV2NC039781	SJAAM2ZV9NC039860	SJAAM2ZV8NC039932	SJAAM2ZV8NC011001
SJAAM4ZV3NC039784	SJAAM2ZV0NC039861	SJAAM2ZV1NC039934	SJAAM2ZVXNC011002
SJAAM2ZV1NC039786	SJAAM2ZV2NC039862	SJAAM2ZV5NC039936	SJAAM2ZV1NC011003
SJAAM2ZV7NC039789	SJAAM2ZV4NC039863	SJAAM2ZV9NC039938	SJAAM2ZV1NC011017
SJAAM2ZV3NC039790	SJAAM2ZV8NC039865	SJAAM2ZV7NC039940	SJAAM2ZV3NC011018
SJAAM2ZV7NC039792	SJAAL14V9NC039880	SJAAM2ZV0NC039942	SJAAM2ZV5NC011022
SJAAM2ZV0NC039794	SJAAM2ZV1NC039884	SJAAM2ZV2NC039943	SJAAM2ZV7NC011023
SJAAM2ZVXNC039799	SJAAD14V1NC039885	SJAAM2ZV4NC039944	SJAAM2ZV9NC011024
SJAAM2ZV4NC039801	SJAAD14V3NC039886	SJAAM2ZV6NC039945	SJAAM2ZV0NC011025
SJAAM2ZVXNC039804	SJAAM2ZV7NC039887	SJAAM2ZV8NC039946	SJAAM2ZV2NC011026
SJAAM2ZV1NC039805	SJAAM2ZV9NC039888	SJAAD14VXNC039948	SJAAM2ZV6NC011028
SJAAM2ZV7NC039808	SJAAM2ZV0NC039889	SJAAM2ZV3NC039949	SJAAD14V6NC011029
SJAAM2ZV9NC039809	SJAAM2ZV7NC039890	SJAAM2ZVXNC039950	SJAAM2ZV4NC011030
SJAAM2ZV5NC039810	SJAAM2ZV9NC039891	SJAAL14V6NC039951	SJAAM2ZV6NC011031
SJAAL14V7NC039814	SJAAM2ZV0NC039892	SJAAM2ZV3NC039952	SJAAM2ZV8NC011032
SJAAM2ZV8NC039817	SJAAM2ZV4NC039894	SJAAM2ZV5NC039953	SJAAD14V8NC011033
SJAAD14VXNC039819	SJAAM2ZV6NC039895	SJAAM2ZV9NC039955	SJAAM2ZV1NC011034
SJAA514V5NC039823	SJAAM2ZVXNC039897	SJAAM2ZV0NC039956	SJAAM2ZV3NC011035
SJAAM2ZV7NC039825	SJAAM2ZV3NC039899	SJAAM2ZV2NC039957	SJAAM2ZV5NC011036
SJAAM2ZV9NC039826	SJAAM2ZV1NC039903	SJAAM2ZV4NC039958	SJAAM2ZV0NC011039
SJAAL14V5NC039827	SJAAM2ZV5NC039905	SJAAM2ZV6NC039959	SJAAM2ZV7NC011040
SJAAM2ZV4NC039829	SJAAM2ZV7NC039906	SJAAM2ZV2NC039960	SJAAM2ZVXNC011047
SJAAM2ZV0NC039830	SJAAM2ZV9NC039907	SJAAM2ZV4NC039961	SJAA514V9NC011068
SJAAM2ZV2NC039831	SJAAM2ZV0NC039908	SJAAM2ZV6NC039962	SJAAM2ZV9NC011069
SJAAD14VXNC039836	SJAAM2ZV2NC039909	SJAAM2ZVXNC039964	
SJAAM2ZV3NC039837	SJAAD14V7NC039910	SJAAM2ZV3NC039966	

Engine and automatic transmission hydraulic lifting table - To prepare

General Information

 **WARNING**

For safety reasons refer to the operating manual supplied with the table BEFORE using the hydraulic lifting table.

This document shows the procedures for setting up the Hydraulic lifting table -VAS 6131-. This document does not cover the steps required to prepare the car prior to raising the engine and automatic transmission support pillars into place, refer to the relevant engine and automatic transmission remove and fit procedure before setting up the pillars.

 **WARNING**

Suitably secure the engine and automatic transmission to the hydraulic table –VAS 6131-

Engine and automatic transmission hydraulic lifting table - To set up

- Check that the lifting table bed is level by using the spirit level -arrow- at the front of the table. Adjust as necessary using the control box.

- Allow the table bed to float, release the locking levers - arrow- on the side of the bed.

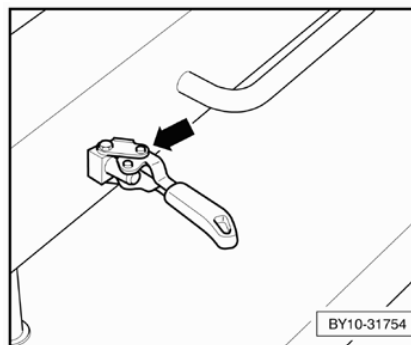
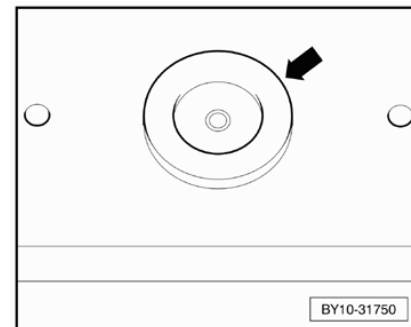
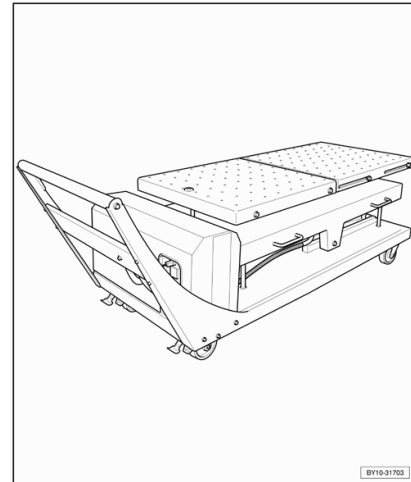

The Hydraulic lifting table -VAS 6131- requires a 3 phase electricity supply and armoured lead, to be sourced from a local qualified supplier.

- Check the hydraulic oil level, the tank is situated at the front of the table under the blue housing.



WARNING

The following procedure should only be carried out by qualified personnel:

- Briefly test the table, refer to the "Engine and automatic transmission hydraulic lifting table controls" section below.
- Using the controls, lift the table. If the table rises then the operating voltage has the correct rotating field.
- If the table fails to operate or the motor turns in the wrong direction, disconnect from the electricity supply from the wall socket, open the socket, swap connections L1 and L2. This reverses the direction of the motor.

Engine and automatic transmission hydraulic lifting table controls

The table controls are as follows:

- ◆ Vertical lift = Hold button -1- and press button -4-.
- ◆ Fast vertical lift = Hold button -2- and press button -4-.
- ◆ Vertical descent = Hold button -1- and press button -3-.
- ◆ Fast vertical descent = Hold button -2- and press button -3-.
- ◆ Lift the rear end (handle end) of the table = Press button -5-.
- ◆ Lift the front of the table = Press button -6-.
- ◆ Lift the left hand side of the table = Press button -7-.
- ◆ Lift the right hand side of the table = Press button -8-.

Engine, automatic transmission and front sub frame support pillars - To set up

Bentayga 4.0L V8

Special tools and workshop equipment required

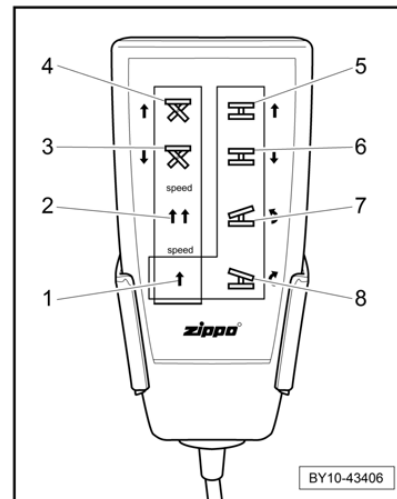
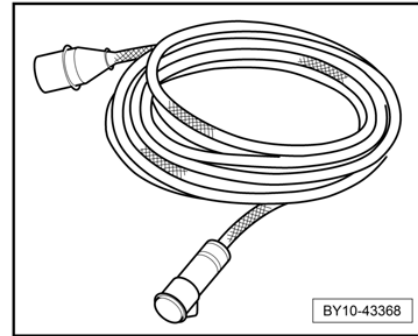

- ◆ Hydraulic lifting table -VAS 6131-

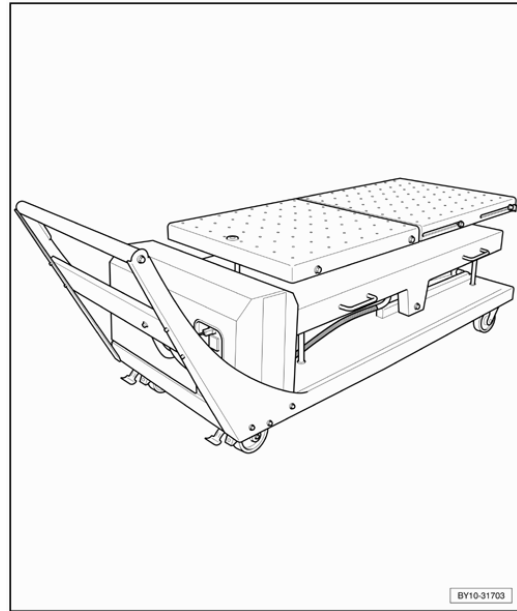

- ◆ Support set -VAS 6131/10-

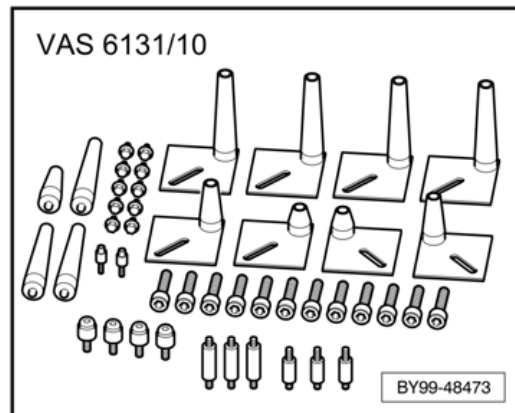

- ◆ Support set -VAS 6131/13-

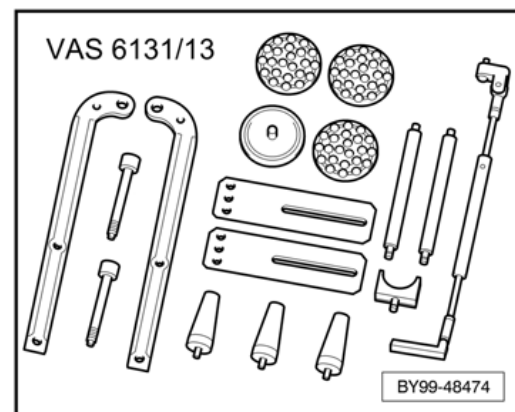

 **Caution**

When raised, the engine and automatic support pillars are located in close proximity to hoses and pipework. Ensure that all pillars are fully located in their locating points prior

to supporting the sub frame, engine and automatic transmission. Failure to do so may result in damage to the underside of the car.

 Note

It is recommended that all procedures are carried out with the help of an assistant to ensure that ALL pillars are fully located in their locating points prior to supporting the sub frame, engine and automatic transmission.

Attach the tool elements to the Hydraulic lifting table -VAS 6131- as shown:

B5 - Subframe - Front left

Plate -VAS 6131/10-1-

Support -VAS 6131/10-4-

Threaded support -VAS 6131/10-5-

Support pin -VAS 6131/10-8-

G5 - Subframe - Front right

Plate -VAS 6131/10-1-

Support -VAS 6131/10-4-

Threaded support -VAS 6131/10-5-

Support pin -VAS 6131/10-8-

C8 - Suspension and steering upright - Left

Support -VAS 6131/13-5-

Threaded support -VAS 6131/10-5-

Pad -VAS 6131/13-2-

F8 - Suspension and steering upright - Right

Support -VAS 6131/13-5-

Threaded support -VAS 6131/10-5-

Pad -VAS 6131/13-2-

B12 - Subframe - Rear outer left

Plate -VAS 6131/10-1-

Support -VAS 6131/10-4-

Threaded support -VAS 6131/10-5-

Support pin -VAS 6131/10-6-

G12 - Subframe - Rear outer right

Plate -VAS 6131/10-1-

Support -VAS 6131/10-4-

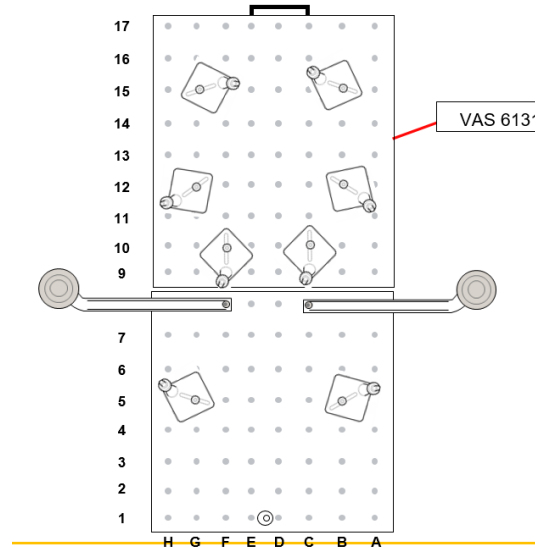

Threaded support -VAS 6131/10-5-

Support pin -VAS 6131/10-6-

C10 - Transmission - Front left

Plate -VAS 6131/10-1-

Support -VAS 6131/10-4-

Threaded support -VAS 6131/10-5-

Transmission support pin -WT 10365-

F10 - Transmission - Front right

Plate -VAS 6131/10-1-

Support -VAS 6131/10-4-

Threaded support -VAS 6131/10-5-

Transmission support pin -WT 10365-

G15 - Transmission mount – Right Rear

Plate -VAS 6131/10-1-

Support -VAS 6131/10-3-

Threaded support -VAS 6131/10-5-

Transmission support pin -VAS 6131/10-11-

B15 - Transmission mount – Left Rear

Plate -VAS 6131/10-1-

Support -VAS 6131/10-3-

Threaded support -VAS 6131/10-5-

Transmission support pin -VAS 6131/10-11-

Positioning the support pillars

Raise the Hydraulic lifting table -VAS 6131- until all

– supports positioned in close proximity to the points as shown below:

– Sub frame - Front outer left & right - Positions B5 &

G5

In the lower support bosses

 Note

RH side shown, LH side symmetrically opposite.

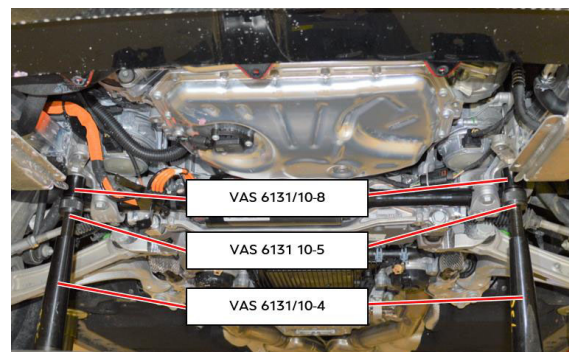

- **Sub frame - Rear left & right** - Positions B12 & G12

In the lower support bosses



Note

RH side shown, LH side symmetrically opposite.

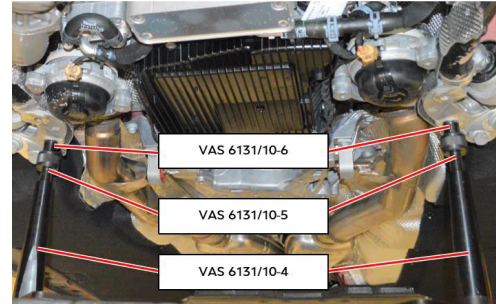

- **Suspension and steering uprights - LH & RH** - Positions C8 & F8

Supporting the suspension levers and steering uprights



Note

RH side shown, LH side symmetrically opposite.

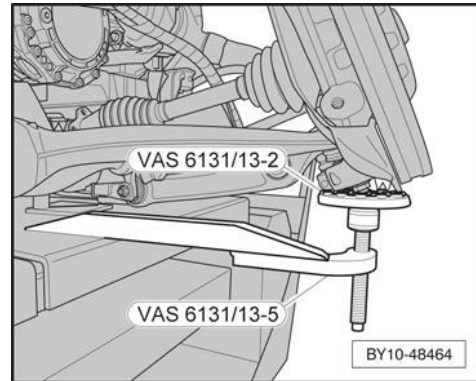

- **Transmission - Front left** - Position C10

Under the head of the corner fixing on the lower automatic transmission sump, next to the "mechatronic" electrical connection

- **Transmission - Front right** - Position F10

Under the head of the corner fixing on the lower automatic transmission sump, behind the differential valve

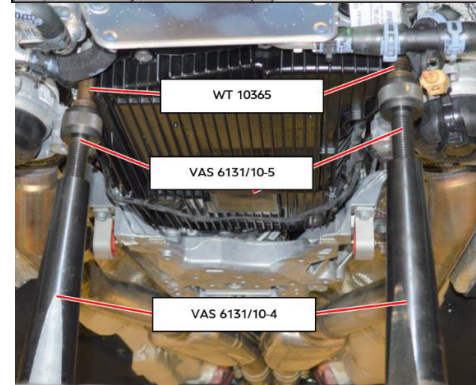

- **Transmission - Rear** - Position B15 & G15

Supporting the Gearbox body mounting

Wind all supports upwards until they are located but not fully supporting the sub frame, engine and automatic transmission assembly.

- Slowly raise the table to support the engine, sub frame and automatic transmission.

After conformation that the engine, sub frame and automatic transmission are correctly supported, refer back to the step **Lowering the engine and automatic transmission**

- **assembly** in section "Engine and automatic transmission - To remove and fit".

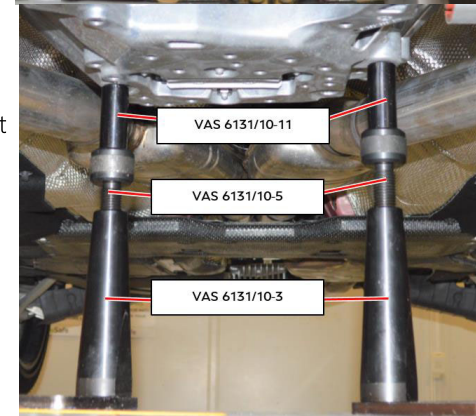

→ Rep.-Gr.10

PAGE LEFT INTENTIONALLY BLANK

1. Remove rear high-pressure fuel line:

Special tools and workshop equipment required

◆ Torque wrench -VAG 1331 -

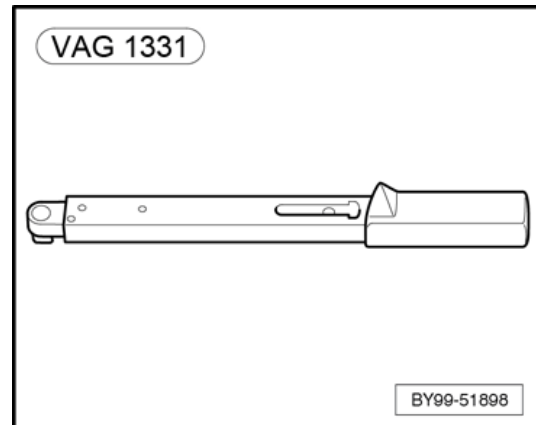

◆ Tool insert AF 17 -VAG 1331/6-

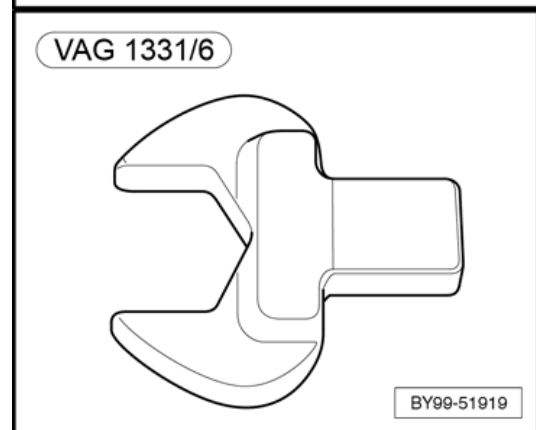

Consumables

Microgleit DF977S lubricant (refer to electronic parts catalogue "ETKA")

Removal

– Remove the fixings -1 to 3- (9 Nm) securing the RH turbocharger coolant pipe.

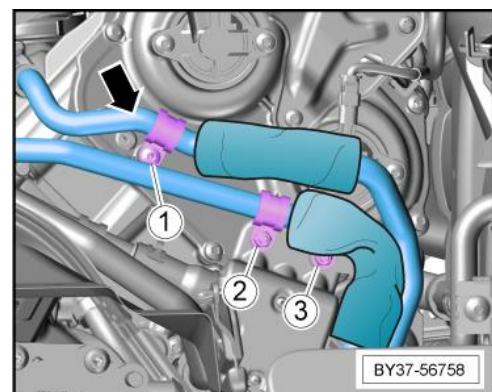

- Remove the fixing -arrow- (9 Nm), detach the turbocharger coolant pipe -1-. DISCARD the O-ring and washer.

Access to the fixing is tight.

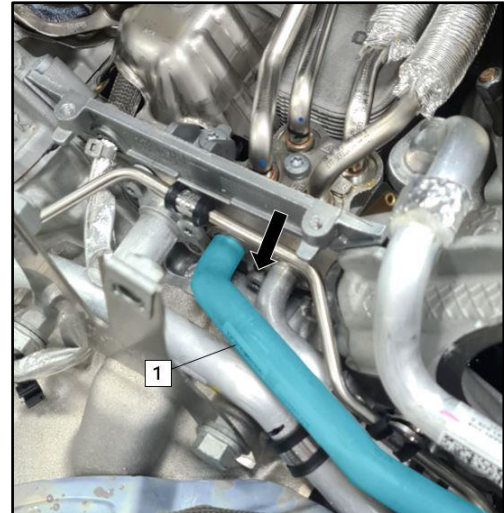

- Remove the two fixings -arrows- (9 Nm) securing the RH turbocharger coolant pipe -1- and the "OPF" pipe -2- (where fitted).

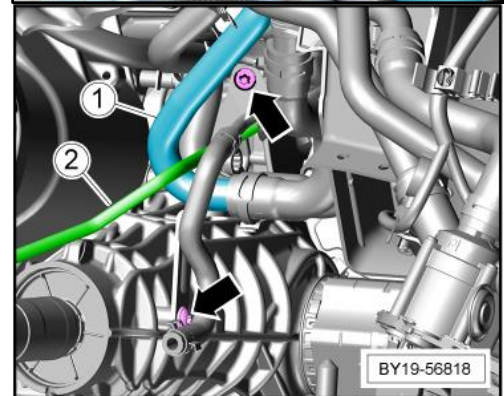

- Remove the fixings -1- (9 Nm) and -2- (1.5 Nm) and detach the heatshield -3-.

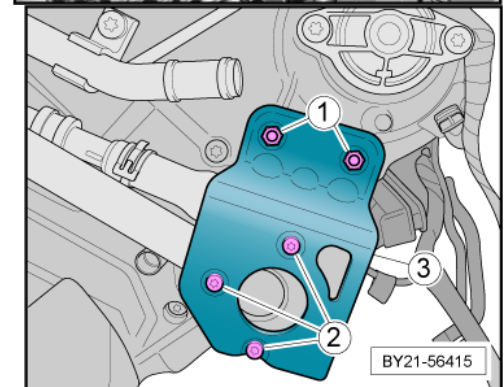

Bank 1

- Release the lambda sensor cable -1- at the clipping point -arrow-.
- Disconnect the electrical connections -2- and release the harness from the clipping points.
- Remove the fixings -3- (8 Nm) and detach the fuel pump crash assembly -4-.

Bank 2

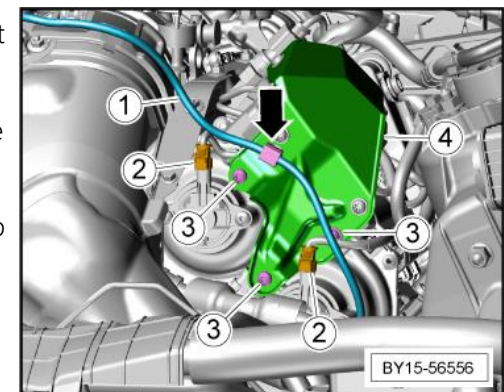

- Remove the three fixings -1- (8 Nm) and detach the fuel pump crash assembly -2-.

Continuation for both sides

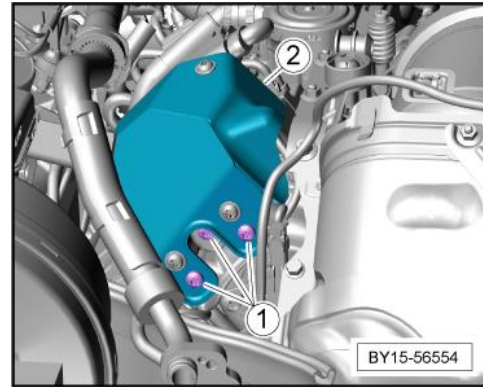

- On the RH side of the engine, disconnect the harness connector -1- from the pressure sensor -2-.
- Remove the fixing -arrow- (9 Nm) securing the pressure sender assembly.
- Undo the union nut -3- securing the high-pressure pipe to the fuel pump.

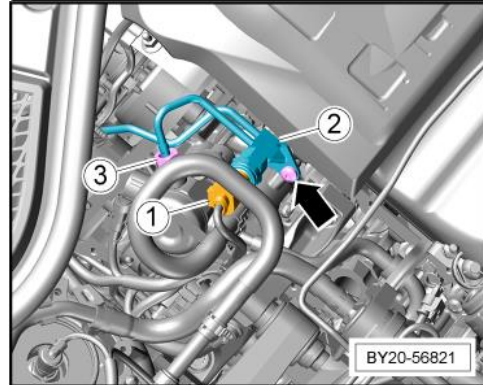

- On the LH side of the engine, undo the union nut -4- (8 Nm + 50°).
- Remove the fixing -5- (9 Nm) securing the P-clip.



Note

Disregard items -1, 2 & 3-.

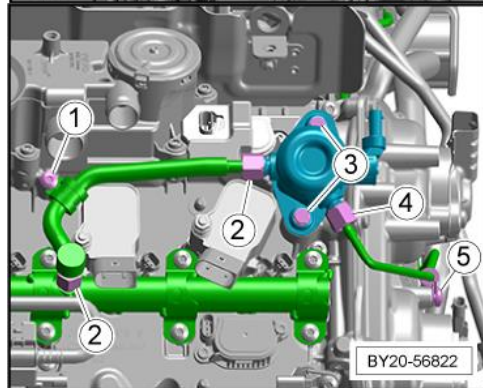

- Remove the fixings -arrows- (9 Nm) securing the P-clips and detach the fuel link pipe -1- from the engine.

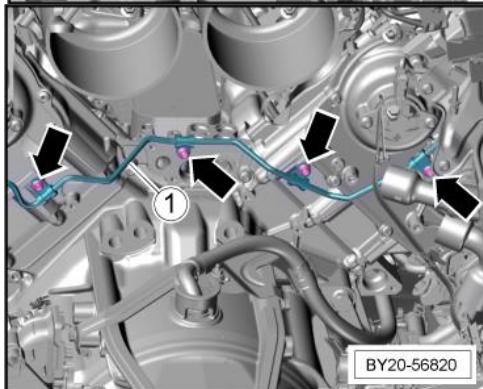

2. Remove upper chain housing covers:



Caution

Dirt and contamination

Risk of damage to units or components

— Protect components from dirt and contamination.

— Secure components to prevent them from falling down.

— Clean or replace dirty components.



Note

The procedure for removing and installing is described for one side as an example. The procedure for the other side is practically identical.

Removal

- Unscrew fixings -2- (9 Nm).
- Press off chain housing cover -1- at a suitable point and set it down on a clean surface.

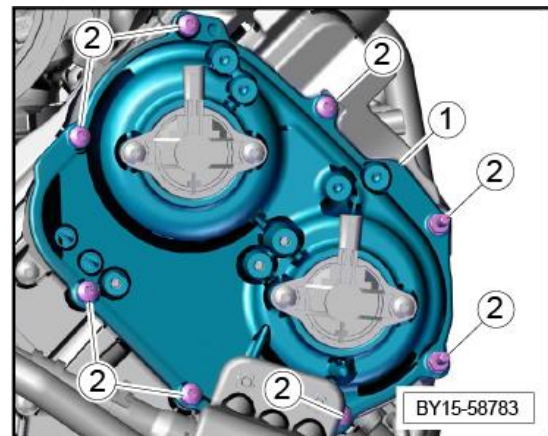

3. Remove oil mist separators:

Removal

- Remove the turbocharger heatshields upper sections.

Bank 1

- Disconnect the pipes -1- from the oil mist separator.

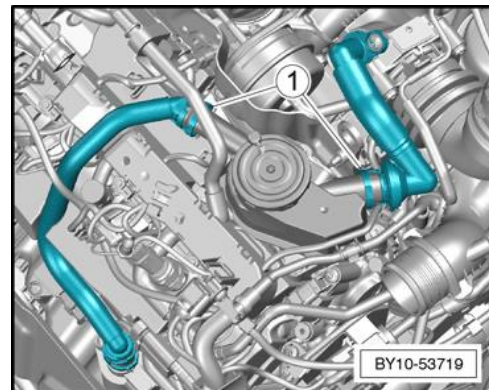

- Loosen the captive fixings -2- (9 Nm) that retain the oil mist separator to the cylinder head cover.

Note

The foremost fixing may be obstructed by sound deadening, suitably peel back the material until the fixing is accessible.

- Remove the oil separator and DISCARD the seal.

Bank 2

- Disconnect the vent lines -2- from the oil mist separator.

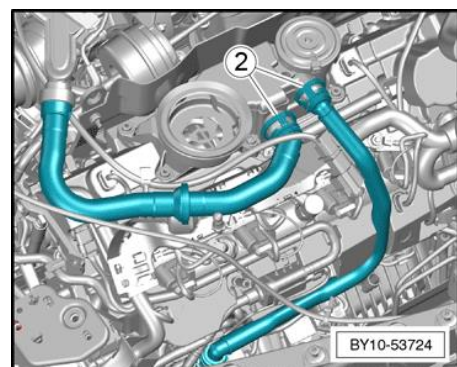
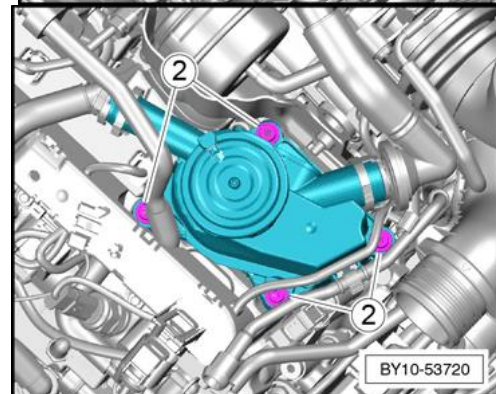

- Loosen the captive fixings -2.....7- (9 Nm) that retain the oil mist separator -1- to the cylinder head cover.



Note

Fixings -2, 4 and 6- may be obstructed by sound deadening, suitably peel back the material until the fixings are accessible.

Oil filler cap shown not fitted for illustration purposes only.

- Remove the oil separator -1- and DISCARD the seal.

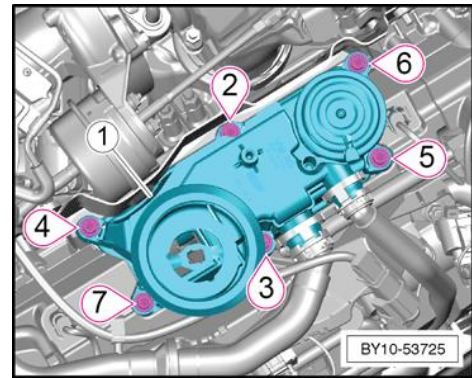

4. Remove ignition coils:

Consumables

Silicone paste -G052565A1- (refer to ETKA)

Removal

Bank 1

- Remove the fixing -3- (55 Nm), the fixing -4- (20 Nm) and the engine mount bracket -2-.



Note

Disregard -1-.

- Disconnect the lower quick connect -1- and detach the vent line.
- Remove the nuts -2- (9 Nm) for the cylinder head harness carrier.

- Disconnect ALL harness connectors from the following components;

- ◆ -1- Ignition coils
- ◆ -2- Cylinder deactivation solenoids
- ◆ -3- Fuel pressure sensor
- ◆ -4- Fuel injectors
- ◆ -5- Camshaft position sensor

- Carefully move the harness to one side to allow access to the ignition coils.



Caution

Take care not to put too much tension on the harness.

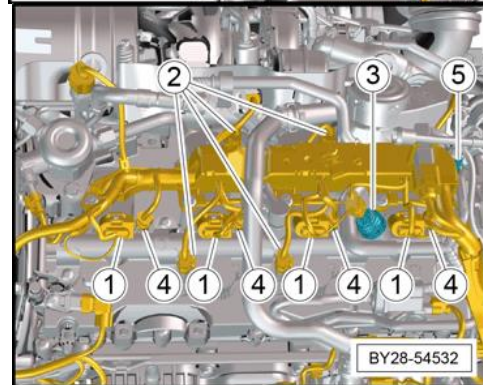
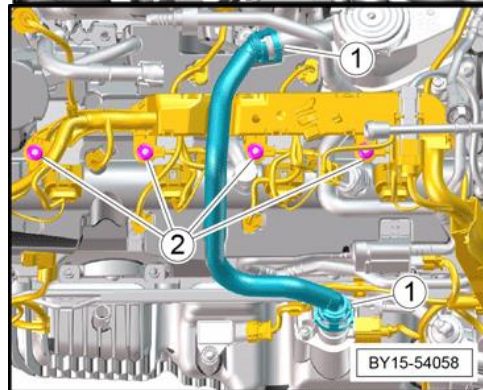
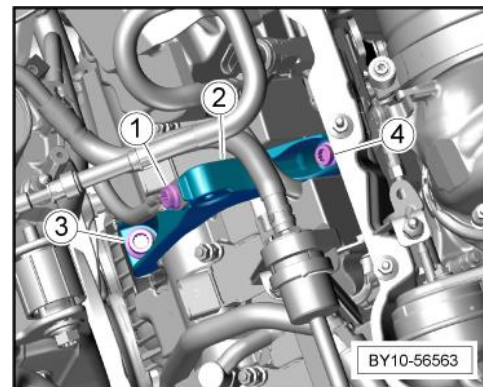

- Remove the studs -1- (9 Nm) for the ignition coils.
- Carefully extract the ignition coil from the cylinder head.

i Note

Number each ignition prior to removal to aid installation.

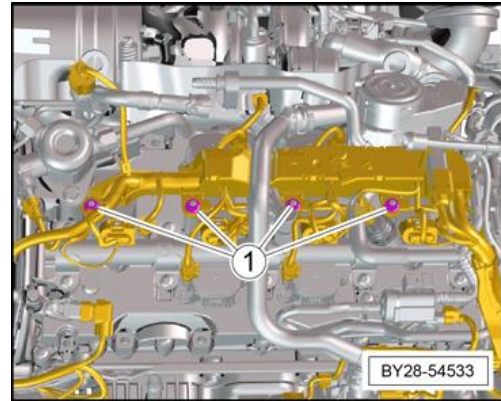

Bank 2

- Disconnect the two electrical connections -2 & 3- and release from their clipping points.

i Note

Disregard -1-, previously disconnected.

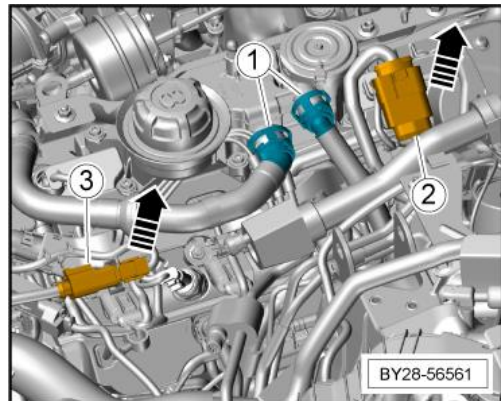

Disconnect the lower 'quick-connect' (not shown) and remove the vent line.

Disconnect the vacuum pipe 'quick-connect' from the intake manifold.

- Disconnect ALL electrical harness connectors from the following components:

- ◆ -1- Ignition coils
- ◆ -2- Cylinder deactivation solenoids
- ◆ -3- Fuel pressure sensor
- ◆ -4- Fuel injectors

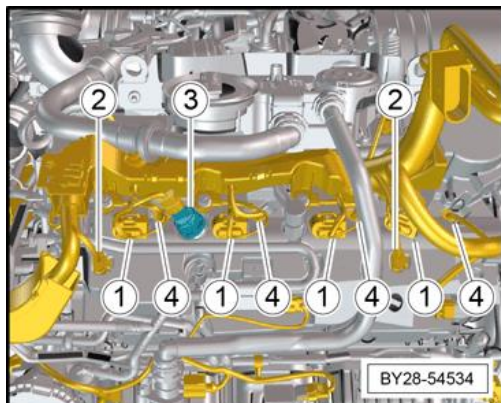

- Remove the nuts -1- (9 Nm) and move the harness to one side to allow access to the ignition coils.

 **Caution**

Take care not to put too much tension on the harness.

- Remove the studs -2- (9 Nm) for the ignition coils.
- Carefully extract the ignition coil from the cylinder head.

 **Note**

Number each ignition prior to removal to aid installation.

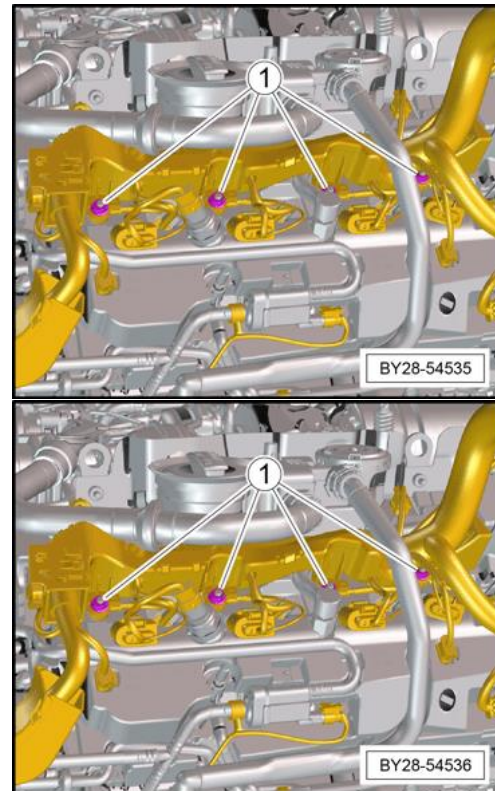

5. Remove high-pressure fuel lines, banks 1 and 2:

Special tools and workshop equipment required

- ◆ Torque wrench -VAG 1331 -

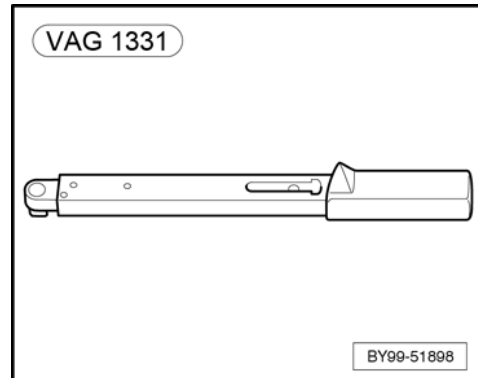

- ◆ Tool insert AF 17 -VAG 1331/6-

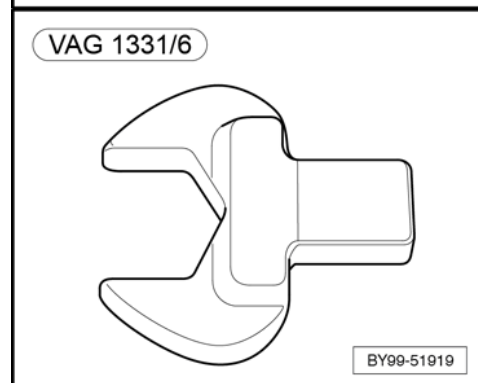

Consumables

Microgleit DF977S lubricant (refer to electronic parts catalogue "ETKA")

Removal

Bank 1

- Remove the fixing -1- (9 Nm) for the fuel line clamp.
- Unscrew the union nuts -2- and remove the fuel line.

Bank 2

- Remove the fixing (9 Nm) -1- for the fuel line clamp.
- Unscrew the union nuts -2- and remove the fuel line.

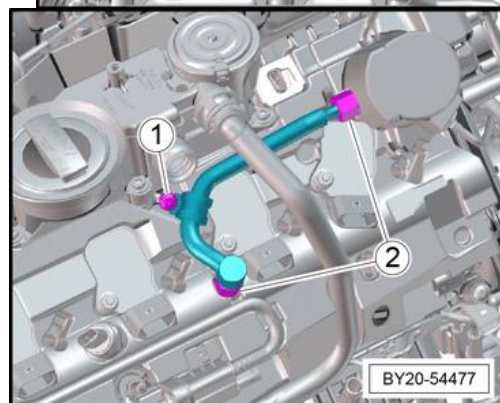
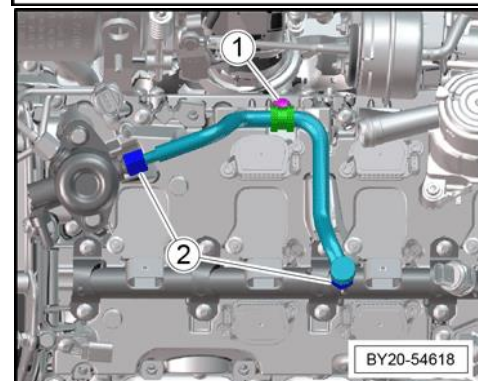

6. Remove high-pressure fuel pumps:

There are two high pressure fuel pumps fitted to the engine:

- ◆ The High-pressure pump -N290- is mounted on the rear top surface of the bank one camshaft cover.
- ◆ The High-pressure pump -N402- mounted on the rear top surface of the bank two camshaft cover.

The removal of the high-pressure fuel pump is the same for both sides of the engine unless stated otherwise.

Special tools and workshop equipment required

- ◆ Torque wrench -VAG 1331 -

- ◆ Tool insert AF 17 -VAG 1331/6-

Consumables

Microgleit DF977S lubricant (refer to electronic parts catalogue "ETKA")

Removal

- Disconnect the harness connector -1- from the fuel pump.
- Disconnect the fuel pipe union -2- from the high-pressure pump.

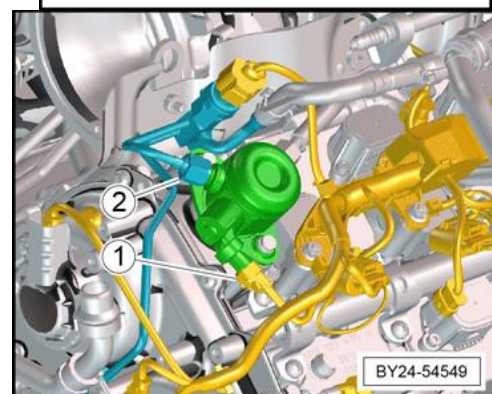
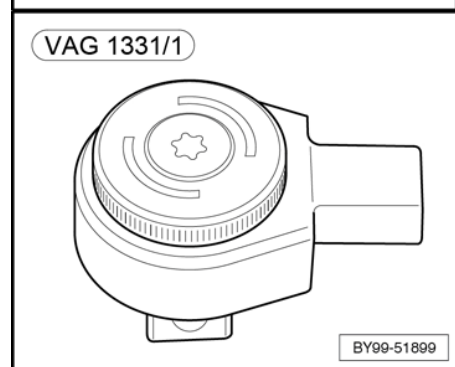
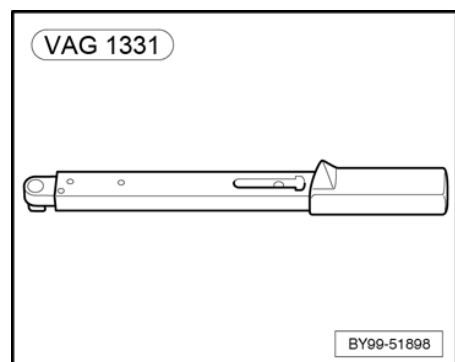

- Lift the sound insulation material up to gain access to the fuel pump fixings.
- Remove the fixings -3- and carefully withdraw the fuel pump from the camshaft cover.

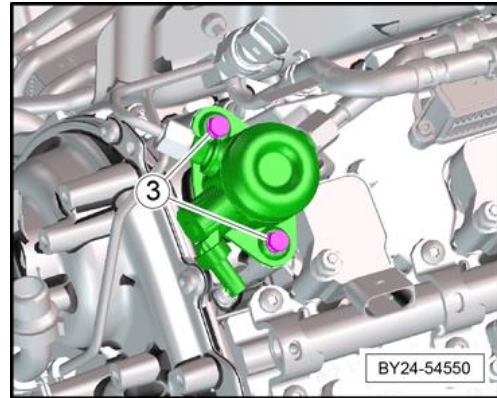

7. Remove fuel rails:

The removal of the fuel rail is symmetrically the same on both banks of the engine unless stated otherwise.

Removal

- Lift the check valve assembly from the guide away from the valve cover -arrow-.
- Remove the sound proof material from the cylinder head -2-.
- Remove the fixings -1.....10- in the sequence shown.
- Detach the fuel rail from the cylinder head, ensuring that the fuel injectors remain seated in the cylinder head.

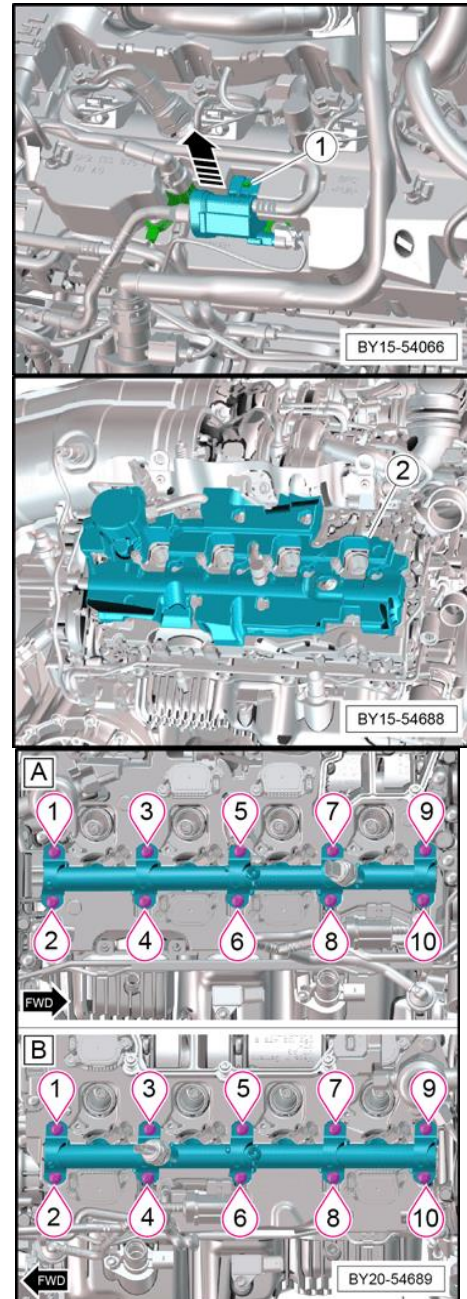

8. Remove cylinder deactivation solenoids:

The cylinder deactivation solenoid system comprises of the following:

- ◆ Camshaft lobe sliding element - which is part of the camshaft assembly and operates on a splined section of the camshaft.
- ◆ CDA activation/ deactivation solenoids (actuators) (4 per engine bank).

Removal

- Remove the fixings -1- (5 Nm) for the relevant cylinder deactivation solenoid.
- Carefully remove the cylinder deactivation solenoid from the cylinder head.
- Repeat for all remaining cylinder deactivation solenoids, noting the locations to aid installation.

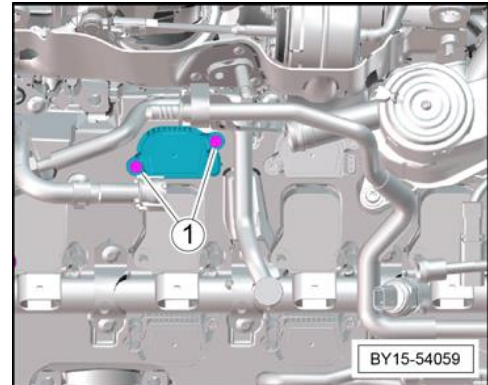

9. Remove fuel injectors:

Special tools and workshop equipment required

Tool set for TSI engines -T10133-

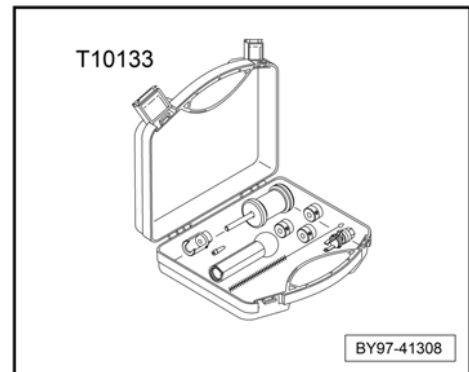

Removal



Note

As the injectors are new, it may be possible to pull them out manually, i.e. without the need for the puller tool. If this is not possible, refer to the steps below.

- Apply Puller -T10133/2A- to the groove of the injector.
- Apply Puller -T10133/16A- over Puller -T10133/2A-, and extract the injector by turning the bolt -1-.
- Repeat for all injectors, taking note of the locations to aid installation.

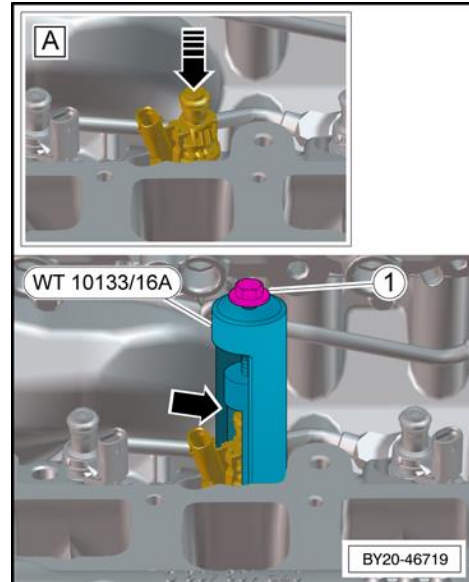

10. Remove mechanical vacuum pump:

The mechanical vacuum pump is located at the front LH side (bank 2) of the cylinder head -arrow-.

Removal

- Remove the fixing -1- retaining the engine harness -2-.
- Detach the quick connect -3- from the pressure tube breather.
- Release the "Springband" clamp -arrow- and detach from the hose -4-.
- Release the pipe assembly -5- from the clipping points for improved access.

- From the top of the vacuum pump, disconnect the vacuum line -2- and the push-on hose -1-.

- Remove the three fixings -3- from the vacuum pump.
- Carefully detach the vacuum pump from the engine.

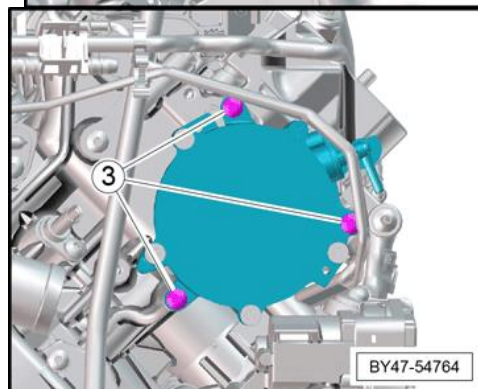
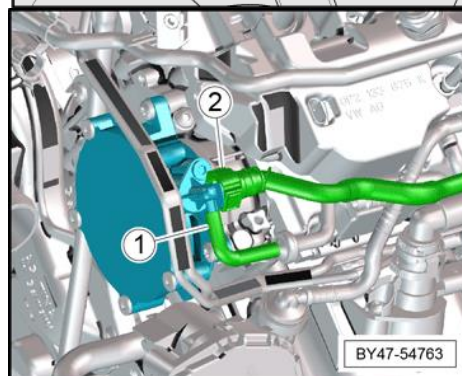
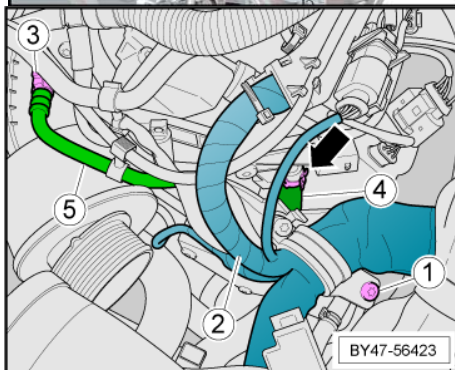
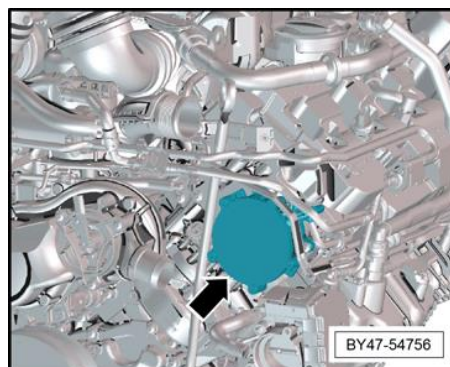

11. Remove pressure pipes:

Special tools and workshop equipment required

Hose clip pliers -ASE 451 492 00 000-.

Removal

LH side (bank 2) only

- Pull the breather stub -1- out from the pressure pipe.

Continuation for both sides

On the appropriate side, release the two captive fixings -

- 2- (9 Nm) and detach the pressure pipe -3- from the centre connecting hose -4-.

An additional fixing may be fitted dependent on model year.

Caution

Blank off all open ports.

- Remove and DISCARD the "O-rings" -arrows- from the breather stub -1- and the pressure pipe -2-.

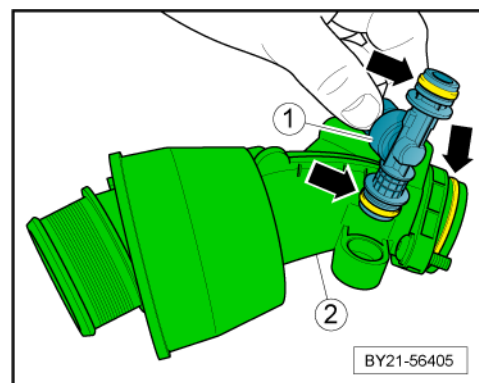
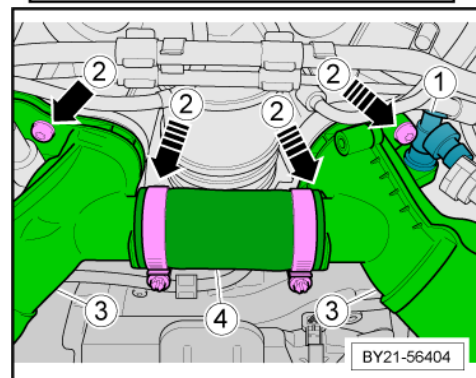
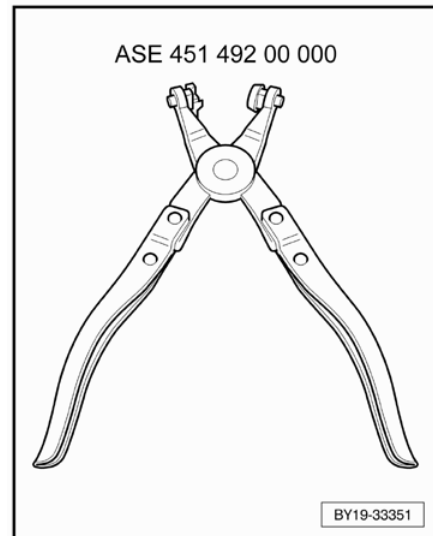

12. Remove camshaft actuators:

The camshaft actuators are located at the rear of cylinder banks 1 and 2, behind the upper chain housing covers.

Special tools and workshop equipment required

- ◆ Counterhold tool -T90001- (not illustrated)
- ◆ Ring wrench insert, a/f 41 -VAS 261 001- (not illustrated)
- ◆ Camshaft clamp -T40331-

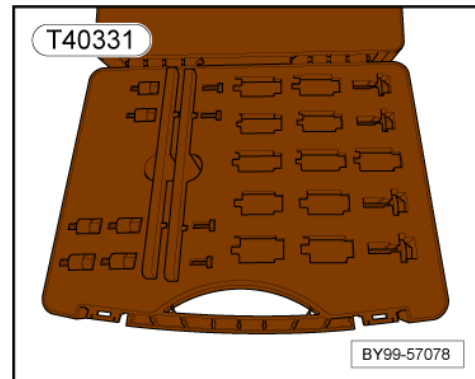

- ◆ Socket E24 -T90000- (not illustrated)
- ◆ Locking pin -T03006-
- ◆ Hook wrench -VAS 261 005- (not illustrated)
- ◆ Counterhold tool -T90002- (not illustrated)
- ◆ Vehicle tester

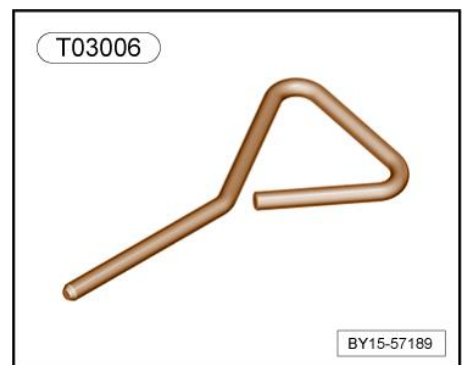

Component overview

Camshaft control

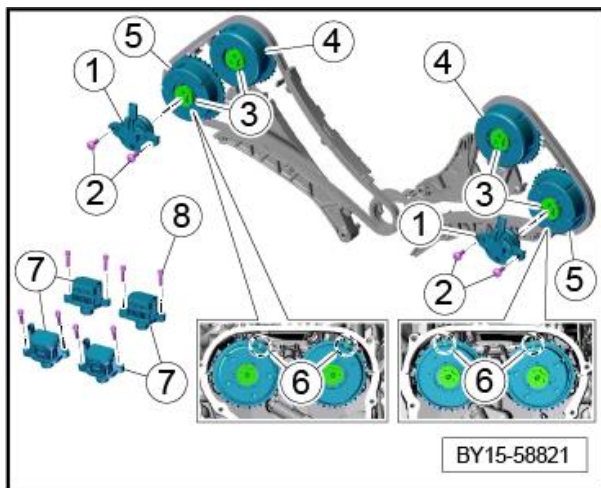

1 - Actuator for camshaft controller

2 - Screws, M6 x 16

Tightening torque: 9 Nm

3 - Central screw for camshaft controller

◆ Replace O-ring

◆ Initial tightening: 27 Nm

◆ Final tightening: 30 Nm +35°

4 - Actuator for outlet camshaft

- 5 - Actuator for intake camshaft
- 6 - Installation marking
- 7 - Valve lift adjustment
- 8 - Screw, M5 x 20

Tightening torque: 5 Nm

Tightening sequence for central screw for camshaft controller (item -3-)

Result:	Cylinder bank:	Camshaft:
1.	Bank 2	Outlet
2.	Bank 2	Intake
3.	Bank 1	Intake
4.	Bank 1	Outlet

Preliminary work

- For bank 2 only, remove the dipstick.



Note

Photos taken with a digital camera are helpful with complicated line routing (engine wire harness).

- Loosen tank ventilation sensor (USA) or dummy (cylinders 1 - 4) -1-.
- Unscrew and remove fastening screw -2-.
- Release and disconnect electric plug connection -3-.
- Loosen tank ventilation sensor (USA) or dummy -1- together with vent line -5- from holder -4-.

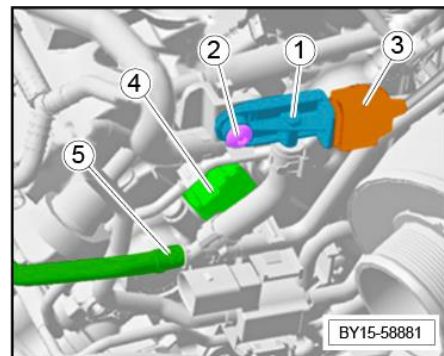

- Loosen change-over valve for water pump -3- and remove holder. Ref: Image

Vacuum System for reference:

- 1- Brake booster vacuum pump
- 2- Vacuum line
- 3- Electric change-over valve for water pump
- 4- Control valve for boost pressure control, cylinders 1 to 4
- 5- Control valve for boost pressure control, cylinders 5 to 8
- 6- Brake booster connection
- 7- Vacuum unit connection

Remove camshaft actuator



Caution

Timing not set correctly

- Risk of engine damage

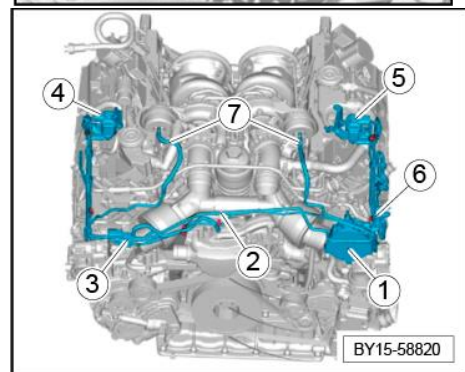

- Rough running engine
- Loss of engine power
- Do not use force when fitting the staking tool.
- Make sure that the gap is equal on both sides.
- When inserting the staking tools, do not use force to turn the camshafts against any resistance.
- The engine must be exactly at top dead centre.
- The opposite cylinder must be at ignition TDC.

 **Caution**

Dirt and contamination

Risk of damage to units or components

- Protect components from dirt and contamination.
- Clean or replace dirty components.

 **Note**

Do not clean the camshaft controller in a parts washer. Only the outside can be cleaned using a clean, lint-free cloth.

 **Note**

Never use the Camshaft clamps -T40331- as a counterhold tool for loosening and tightening the camshaft controllers.

 **Note**

The Counterhold tool -T90001- can only be inserted at one position. The markings -1 and 2- must line up.

- Turn engine clockwise to ignition TDC of cylinder 1.
- Check markings on crankshaft and actuators.
- Secure camshafts.

- Carefully lever out stoppers on the cylinder head cover using a screwdriver.
- Screw adapter -1- into the camshaft housing and tighten to 9 Nm.

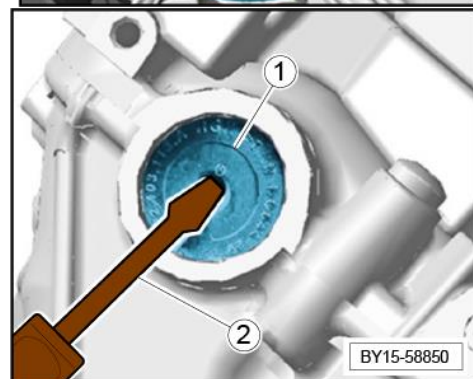
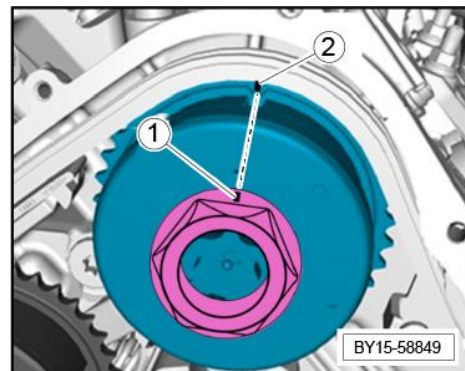

Cylinder bank 1: T40331/2, Cylinder bank 2: T40331/3

i Note

It may be necessary for another person to carefully position the camshafts at the actuators using Counterhold tool - T90001- and Ring wrench insert, a/f 41 -VAS 261 001-.

Camshaft clamp -T40331- must be inserted.

Cylinder bank 1:

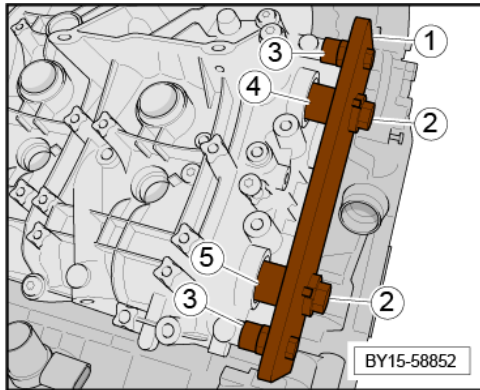
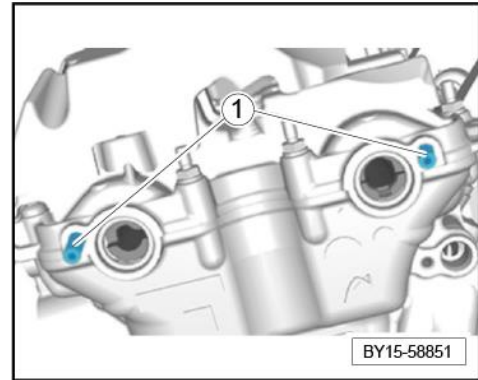

- 1 - -T40331/1- - The letter "A" must be facing you
- 2 - -T40331/9-
- 3 - -T40331/2-
- 4 - -T40331/4- - Outlet camshaft
- 5 - -T40331/6- - Intake camshaft

Cylinder bank 2:

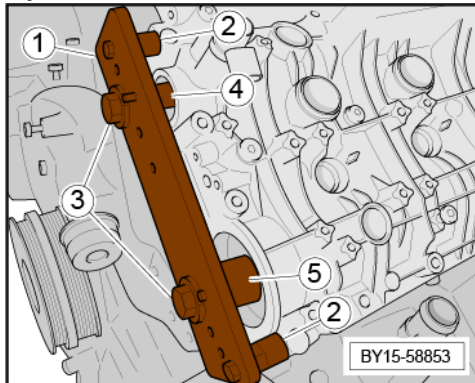

- 1 - -T40331/1- - The letter "B" must be facing you
- 2 - -T40331/9-
- 3 - -T40331/3-
- 4 - -T40331/10- - Outlet camshaft
- 5 - -T40331/8- - Intake camshaft

- Secure the crankshaft at the front of the engine using a suitable 6mm locking pin/drill bit.

⚠ Caution

It may be necessary to rotate the crankshaft to fit the tool securing the crankshaft.

If the engine is turned over by hand using the crank damper bolt, it **MUST** be turned “clockwise” -arrowed- to avoid the possibility of loosening the bolt.

i Note

Prior to removal of the camshaft actuators mark the position of both camshaft actuators, the timing chain and the cylinder head cover to aid installation.

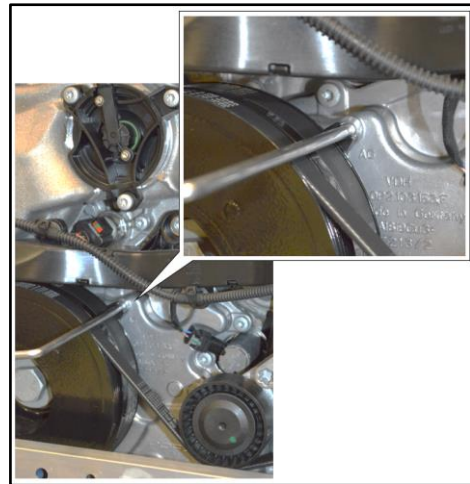

- Loosen and unscrew central valves -1-.
- Counterhold tool -T90001- -2- with Ring wrench insert, a/f 41 -VAS 261 001- -3- must be fitted on the actuators.
- Then loosen central valves -1- using Socket E24 -T90000-.

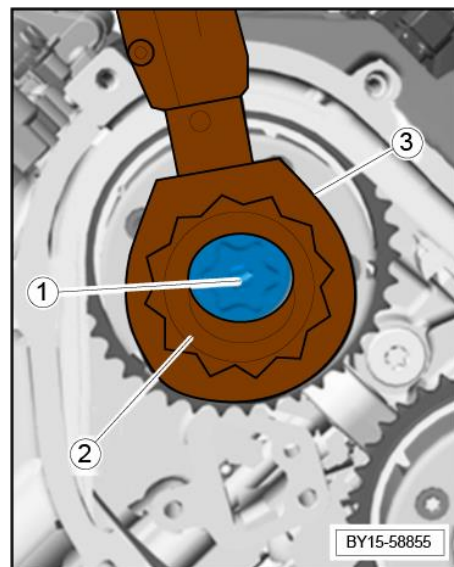

- Fix chain tensioner in place.
- Press the chain tensioner piston back fully. To do this, actuate the tensioning rail by hand.
- Fix the chain tensioner -1- in place using Locking pin -T03006- -3-.

⚠ WARNING

If the tensioner pin is removed without chain guide lever in place, the piston & spring may fly out! (depending on version fitted).

- Unscrew central valves and remove actuators from camshafts and from the timing chain.

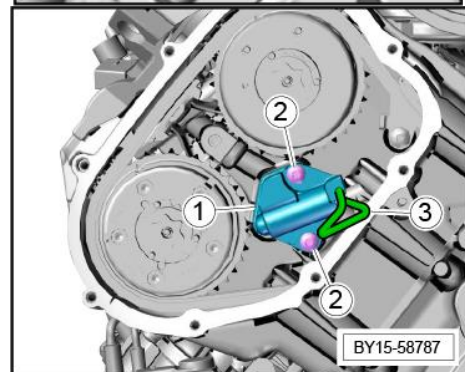

⚠ Caution

Secure the timing chain to prevent it from falling down.

13. Remove cylinder head cover:

The following procedure covers both bank 1 and bank 2 camshaft covers.

Removal



Note

The procedure for removing and installing is described for one side as an example. The procedure for the other side is practically identical, except where shown.

Bank 1

- Remove the fixings -arrows- (20 Nm).
- Remove the bracket-1-.

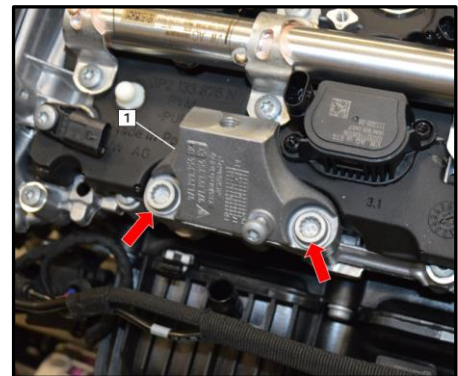

Continuation for both sides

- Remove cylinder head cover -1-.
- Unscrew screws -2- slowly and uniformly from the outside in.
- Remove cylinder head cover -1- (with camshaft clamp fitted) and set it down on a clean surface.

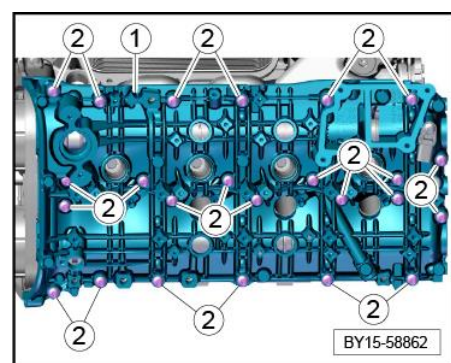

14. Remove valve lifters (hydraulic tappets):

Removal

– If you intend to re-use hydraulic tappets, safety clips and valve levers: Mark allocation of the components using a coloured marker.

- Remove hydraulic tappet -1- and valve lever -2-.
- Take hydraulic tappet -1- with valve lever -2- out of the cylinder head together.



Note

If you intend to re-use hydraulic tappets and valve levers, check that the components are not damaged.

- Check component allocation and check that all components are fitted.
- Remove hydraulic tappet -2- from valve lever -3-.
- Open safety clip -1- carefully.
- Remove safety clip -1- and hydraulic tappet -2-.

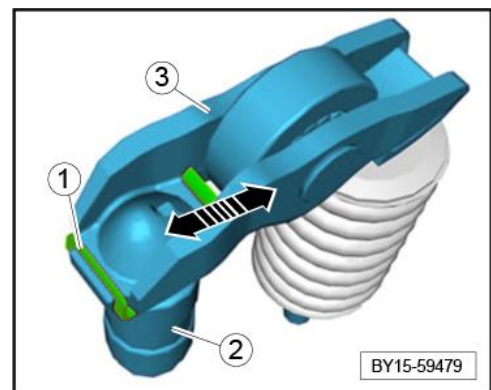
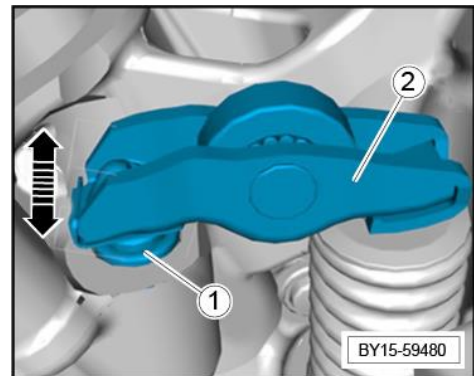

15. Remove spark plugs:

Special tools and workshop equipment required

Spark plug socket (14 mm) commercially available.

Removal



Note

Ensure the area around the spark plugs is free from dirt and debris.

- Using a suitable socket, remove the spark plugs.



Note

When spark plugs are removed, place a suitable clean cloth in the spark plug bore to prevent any dirt ingress.

16 - Valve springs - To remove and fit

General Information

The engine and automatic transmission is required to be removed from the vehicle in order to carry out this procedure. The cylinder head is to remain installed on the engine assembly whilst this procedure takes place.

The automatic transmission does NOT require to be removed from the engine assembly.



WARNING

Before commencing work on and around the engine, ensure that it has cooled sufficiently, failure to do so may cause injury to personnel.

Avoid prolonged and repeated contact with oils and fluids etc.

- ◆ Always protect the skin with impervious gloves.
- ◆ Always wear suitable eye protection.



Caution

Suitably blank open ports to prevent the ingress of dirt, moisture and foreign objects into the engine. Failure to do so may cause irreparable damage to the engine.



WARNING

Danger of objects or loads falling down

Risk of squashing or crushing

- Secure components to prevent them from falling down.



Caution

Dirt and contamination

Risk of damage to units or components

- Protect components from dirt and contamination.
- Clean or replace dirty components.

Special tools and workshop equipment required

- ◆ Guide plate -VAS 5161A/38-

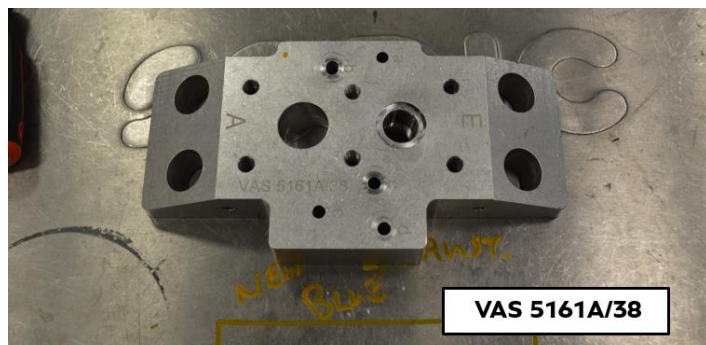

- ◆ Removal and installation device for valve keys -VAS 5161/A-
- ◆ Valve stem seal puller -3364-
- ◆ Press-on tool -3365-
- ◆ Cylinder compression tester

Positioning of Hook -VAS 5161/6- & Anchor -VAS 5161/5 M8- onto Guide plate -VAS 5161A/38- for each cylinder.

It is imperative that the following table and accompanying image is followed to ensure the correct positioning of the Hook -VAS 5161/6- & Anchor -VAS 5161/5 M8- for access and correct leverage.



Cylinder Number	VAS 5161/6 (hook) & VAS 5161/5 M8 (anchor) Position			
	Inlet		Exhaust	
(Bank 1)	Left Valve	Right Valve	Left Valve	Right Valve
1	6	6	3	3
2	6	6	3	2
3	4/5	4/5	3	3
4	4/5	4/5	3	3
(Bank 2)	Inlet		Exhaust	
	Left Valve	Right Valve	Left Valve	Right Valve
5	6	6	3	3
6	6	6	3	3
7	4/5	4/5	3	3
8	4/5	4/5	3	3

Guide plate -VAS 5161A/38- - Hook - VAS 5161/6- & Anchor -VAS 5161/5 M8-

- Use the image and the table to ensure correct positioning of tools.

- ◆ -E- Inlet side
- ◆ -A- Exhaust side



Note

The guide plate "VAS 5161A/38" will only operate when installed as described.

Single use items

Within this procedure there are single use items which must be replaced and not reused. Ensure that new replacements are available prior to starting this procedure.

Preliminary work

- Remove the valve lifters and rocker arms. Refer to "Valve lifter (hydraulic tappet) – To remove and fit".

→ Rep.-Gr.15

- Remove the spark plugs. Refer to the relevant section of "Spark plugs to remove and refit"

→ Rep.-Gr.28

Bank 1 only

- Remove the "C" clip -1- by inserting a suitable tool and gently levering the clip off the valve arm pivot -2-, then carefully move the adjustment rod from the pivot.

- Remove the two fixings -arrows- and withdraw the wastegate actuator -3- from the turbocharger assembly -4- and carefully move aside.

Continuation



Caution

Ensure that ALL the sealer residue is COMPLETELY removed off the cylinder head mating faces prior to installing the Guide plate -VAS 5161A/38-. If any sealer residue is left it will severely effect the removal and installation process of the valve keys.

Removal

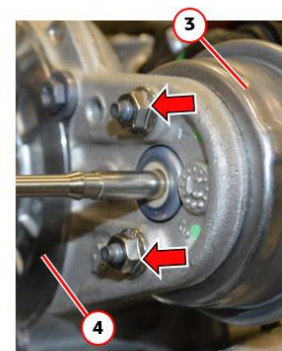
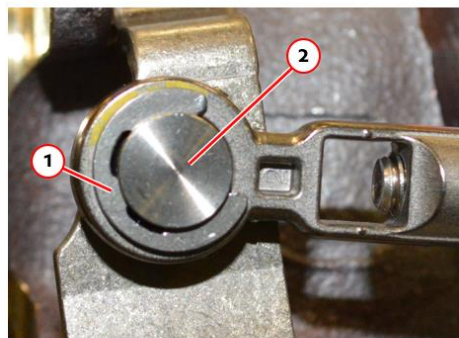
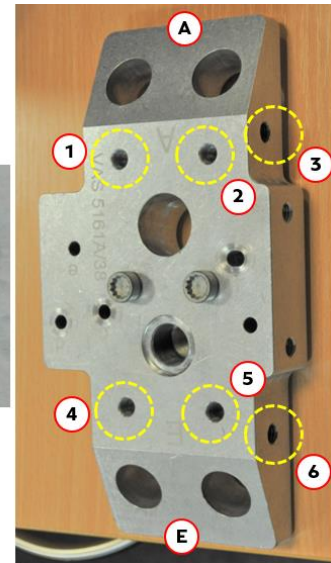
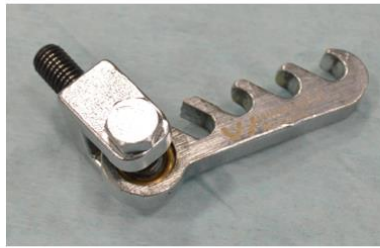

Install two M8x35 fixings -arrows- such as the ones from the "engine cross brace" (N 909 035 02), into the Guide plate -VAS 5161A/38- -1- by hand as shown. These fixings will act as dowels.

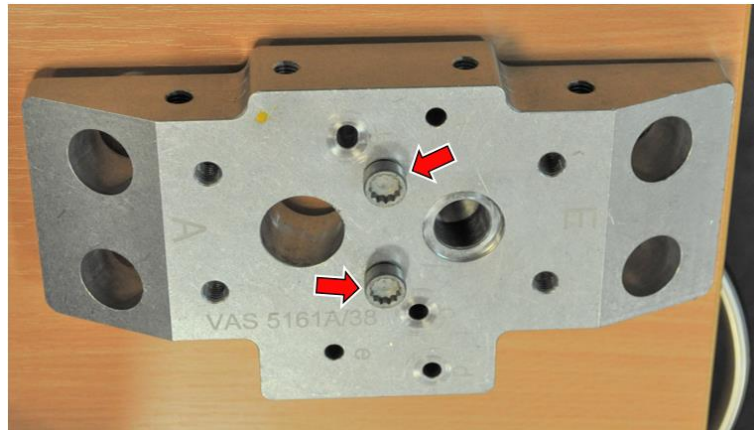

Install the Guide plate -VAS 5161A/38- -1- onto cylinder number one.

Image for illustration purposes only.

Insert two fixings -arrows- to secure the Guide plate -VAS 5161A/38- -1- to the cylinder head.



Note

Two coil pack fixings are ample in the securing of the Guide plate -VAS 5161A/38- to the cylinder head.

On cylinders "four" and "eight" only ONE fixing is used to secure the Guide plate -VAS 5161A/38- to the cylinder head.



Caution

RISK OF DEBRIS OR MATERIALS ENTERING THE ENGINE.

ENSURE that suitable steps are taken to protect any open ports or oil ways during this procedure!

Insert the punch -VAS 5161/3A- -2- from the tool set Removal and installation device for valve keys - VAS 5161A- in the guide plate and loosen any tight valve keys by tapping them "LIGHTLY " with a soft mallet.

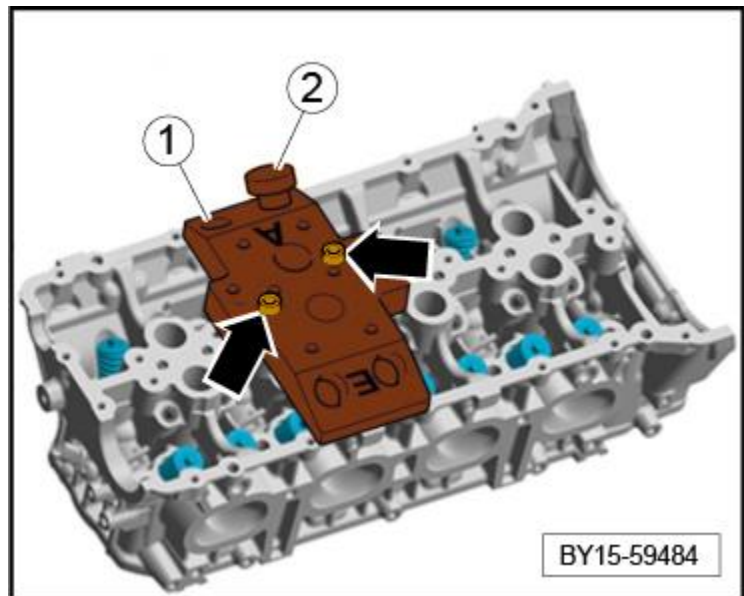

- Screw in the sealing pin -VAS 5161/10- -2- from tool set Removal and installation device for valve keys -VAS 5161A- into the Guide plate -VAS 5161A/38- by hand.

Image for illustration purposes only.

- Screw in the hose adapter -1- from a "Cylinder compression tester kit" hand-tight into the relevant cylinder spark plug thread.

- Connect the compressed air hose to the hose adapter -1- from the "Cylinder compression tester kit".

- Build up overpressure in the relevant combustion chamber.

⚠ WARNING

Compressed air is DANGEROUS! ENSURE that the correct personal protective equipment is worn during the use of compressed air.

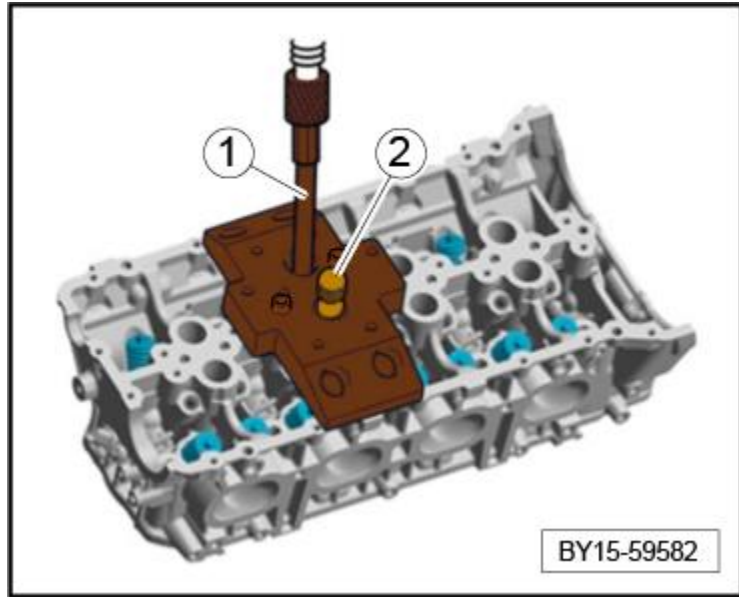

⚠ Caution

Ensure that the compressed air is operating at a minimum of "6 BAR " before continuing.

- Insert the Valve key cartridge -VAS 5161/8A- -4- into the Guide plate -VAS 5161A/38- onto the desired valve assembly.

Image for illustration purposes only.

- Follow the table for the correct positioning of the hook -VAS 5161/6- -2- and anchor -VAS 5161/5 M8- -3- for the removal of each valve set of valve keys.

- Engage the pressure fork -VAS 5161/2- -1- into the hook -VAS 5161/6- -2- and lever the Valve key cartridge -VAS 5161/8A- downwards until it touches the guide plate.

- While applying downward hand pressure to the pressure fork -VAS 5161/2-, turn the knurled screw -arrow- on the Valve key cartridge -VAS 5161/8A- back and forth to press the valve keys apart.

- Once the valve keys have successfully separated, the knurled screw -arrow- will move inwards on its own, and retain the valve keys within the Valve key cartridge -VAS 5161/8A- automatically.

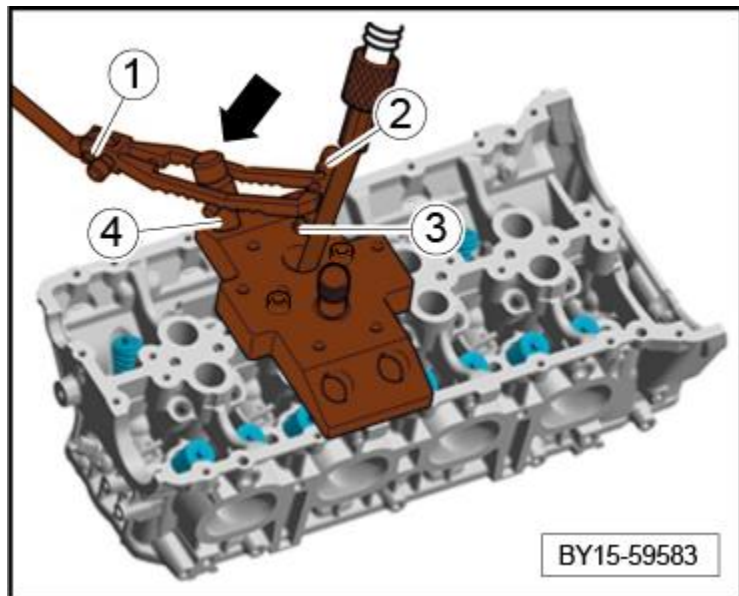

⚠ Caution

Do NOT touch the knurled screw on the Valve key cartridge -VAS 5161/8A- again until instructed.

Relieve the hand pressure from the fork -VAS 5161/2- -1- and remove Valve key cartridge -VAS 5161/8A- -4-.

Using a flexible magnet or by hand, remove the valve-spring cap -1- followed by the valve spring -2- then DISCARD the spring.

Installation of valve spring:



Caution

INLET AND EXHAUST VALVE SPRINGS ARE DIFFERENT! ENSURE that the CORRECT springs are fitted to the CORRECT valves. Refer to ETKA for the correct part numbers for Inlet and Exhaust springs.

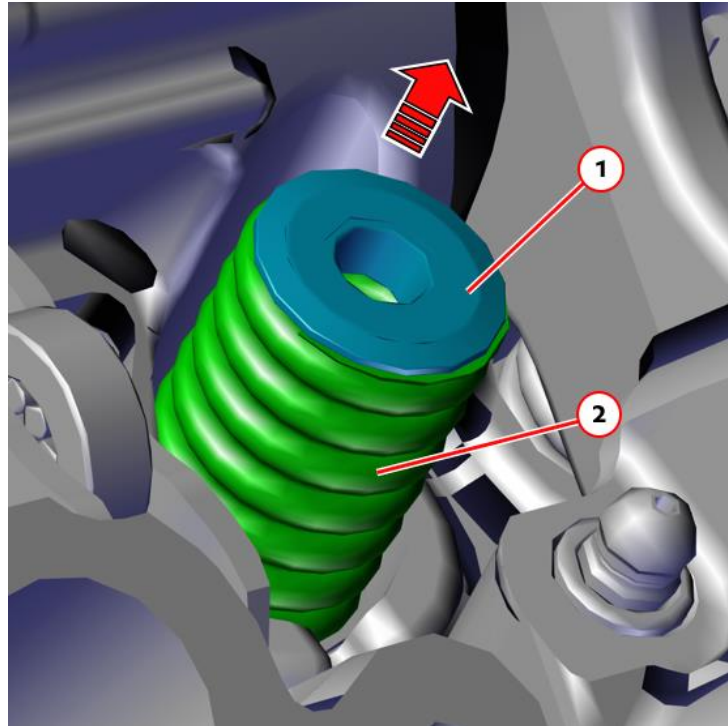

Care point.

Image for illustration purposes only.



Caution

All valve springs -1- (INLET and EXHAUST) MUST be installed with the tightest spring coils -highlighted- closest the cylinder head assembly -arrow-! Failure to adhere to this will cause catastrophic valve train failure.

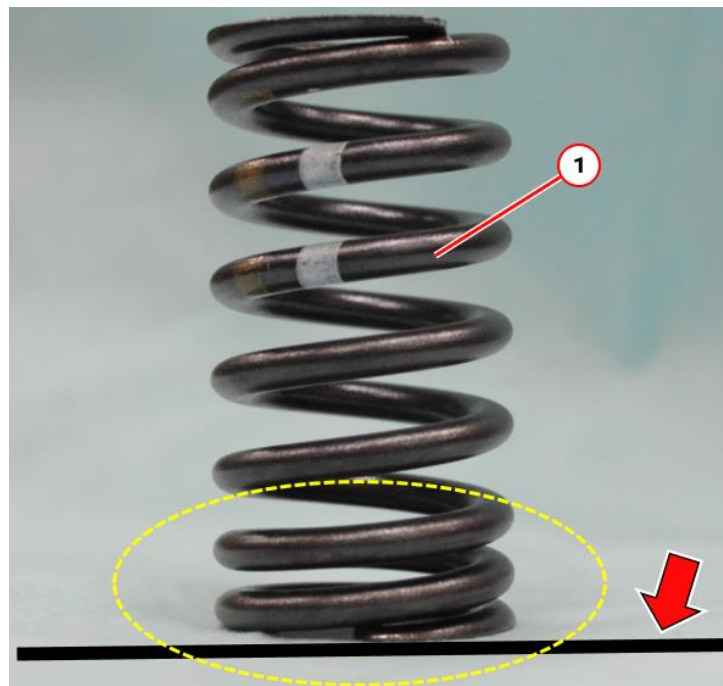

- Insert the NEW correct valve spring and valve-spring cap into position.

Image for illustration purposes only.

- Insert the Valve key cartridge -VAS 5161/8A- -4- into the Guide plate -VAS 5161A/38-.

- Engage the pressure fork -VAS 5161/2- -1- into the hook -VAS 5161/6- -2- and lever the Valve key cartridge -VAS 5161/8A- -4- downwards until it touches the guide plate.

- Pull the knurled screw -arrow- upwards on the Valve key cartridge -VAS 5161/8A-.

- Whilst still pulling up on the knurled screw, slowly release the pressure on the pressure fork -VAS 5161/2- -1-.

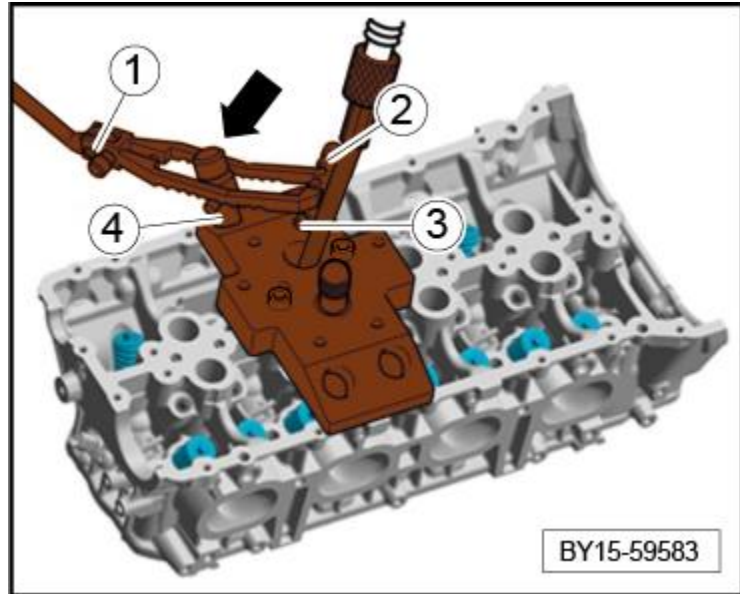

The valve keys are now secured on the valve stem.

- Fully remove the Valve key cartridge -VAS 5161/8A- from the Guide plate -VAS 5161A/38-.

- Perform a visual check, ensuring that both valve keys -1- are secured correctly to the valve stem -2- as shown.



Note

If the valve keys are not secured to the valve stem after the installation process, remove the valve keys and REPEAT the installation process until correct retention has been achieved.

- Repeat the procedure on each remaining valve.

- When all the valves are secured again, ONLY then can the compressed air connection be disconnect.

- Unscrew hose adapter from the spark plug hole.

Continue this procedure on all remaining cylinders.

To remove the valve keys from the cartridge

-VAS 5161/8A-

- If the valve keys were removed from the assembly

cartridge, they must first be inserted into the

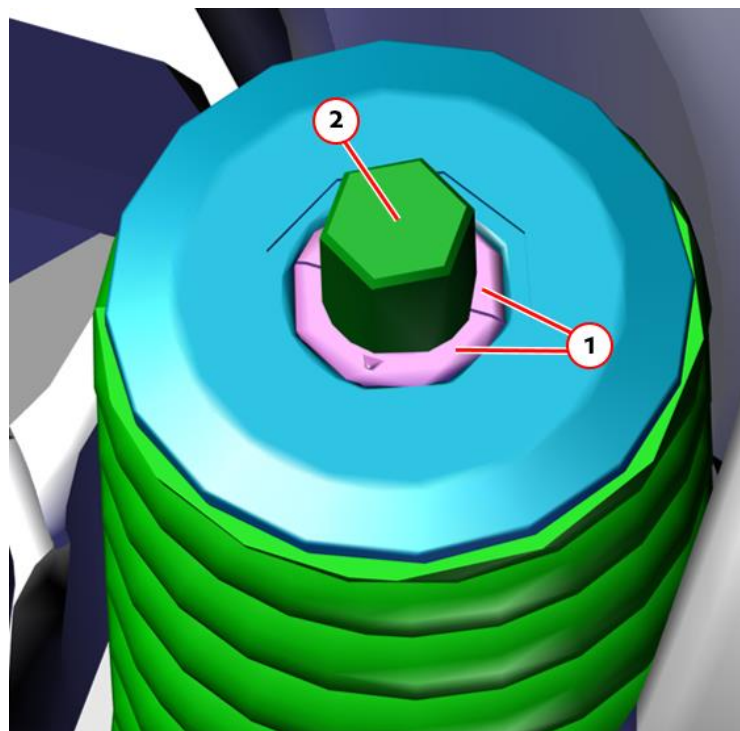

insertion device –VAS 5161/18- -
1- from the tool

set “Removal and installation
device for valve keys”

-VAS 5161A-.

-Insert the valve keys into the
insertion device -VAS

5161/18- -1- .

-The large diameter of the valve
keys must be facing

upwards.

-Press the assembly cartridge -VAS
5161/8A- onto

the valve keys from above and
pick up the valve

keys from the insertion device -
VAS 5161/18- -1-.

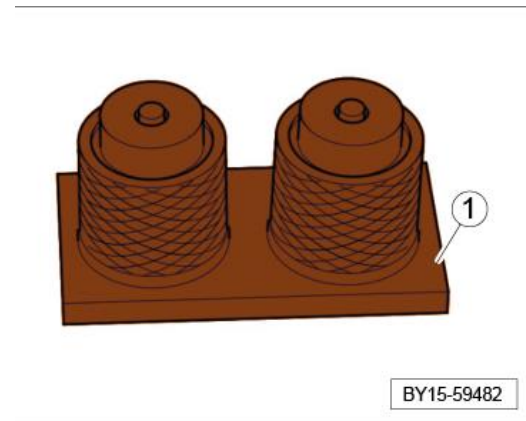

Installation

- Installation is the reverse of the
removal procedure, noting the
following.

Subsequent work

- Install the spark plugs. Refer to the
relevant section of "Spark plugs to
remove and refit"

→ Rep.-Gr.28

- Install the valve lifter (hydraulic
tappet) and valve lever. Refer to
"Valve lifter (hydraulic tappet) – To
remove and fit".

→ Rep.-Gr.15

PAGE LEFT INTENTIONALLY BLANK

Valve springs - To remove and fit

General Information

The engine and automatic transmission is required to be removed from the vehicle in order to carry out this procedure. The cylinder head is to remain installed on the engine assembly whilst this procedure takes place.

The automatic transmission does NOT require to be removed from the engine assembly.



WARNING

Before commencing work on and around the engine, ensure that it has cooled sufficiently, failure to do so may cause injury to personnel.

Avoid prolonged and repeated contact with oils and fluids etc.

- ◆ Always protect the skin with impervious gloves.
- ◆ Always wear suitable eye protection.



Caution

Suitably blank open ports to prevent the ingress of dirt, moisture and foreign objects into the engine. Failure to do so may cause irreparable damage to the engine.



WARNING

Danger of objects or loads falling down

Risk of squashing or crushing

- Secure components to prevent them from falling down.



Caution

Dirt and contamination

Risk of damage to units or components

- Protect components from dirt and contamination.
- Clean or replace dirty components.

Special tools and workshop equipment required

- ◆ Guide plate -VAS 5161A/38-

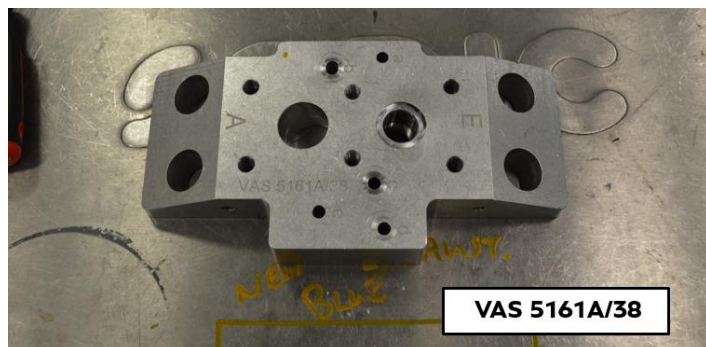

- ◆ Removal and installation device for valve keys -VAS 5161/A-
- ◆ Valve stem seal puller -3364-
- ◆ Press-on tool -3365-
- ◆ Cylinder compression tester

Positioning of Hook -VAS 5161/6- & Anchor -VAS 5161/5 M8- onto Guide plate -VAS 5161A/38- for each cylinder.

It is imperative that the following table and accompanying image is followed to ensure the correct positioning of the Hook -VAS 5161/6- & Anchor -VAS 5161/5 M8- for access and correct leverage.



Cylinder Number	VAS 5161/6 (hook) & VAS 5161/5 M8 (anchor) Position			
(Bank 1)	Inlet		Exhaust	
	Left Valve	Right Valve	Left Valve	Right Valve
1	6	6	3	3
2	6	6	3	2
3	4/5	4/5	3	3
4	4/5	4/5	3	3
(Bank 2)	Inlet		Exhaust	
	Left Valve	Right Valve	Left Valve	Right Valve
5	6	6	3	3
6	6	6	3	3
7	4/5	4/5	3	3
8	4/5	4/5	3	3

Guide plate -VAS 5161A/38- - Hook - VAS 5161/6- & Anchor -VAS 5161/5 M8-

- Use the image and the table to ensure correct positioning of tools.

- ◆ -E- Inlet side
- ◆ -A- Exhaust side



Note

The guide plate "VAS 5161A/38" will only operate when installed as described.

Single use items

Within this procedure there are single use items which must be replaced and not reused. Ensure that new replacements are available prior to starting this procedure.

Preliminary work

- Remove the valve lifters and rocker arms. Refer to "Valve lifter (hydraulic tappet) – To remove and fit".

→ Rep.-Gr.15

- Remove the spark plugs. Refer to the relevant section of "Spark plugs to remove and refit"

→ Rep.-Gr.28

Bank 1 only

- Remove the "C" clip -1- by inserting a suitable tool and gently levering the clip off the valve arm pivot -2-, then carefully move the adjustment rod from the pivot.

- Remove the two fixings -arrows- and withdraw the wastegate actuator -3- from the turbocharger assembly -4- and carefully move aside.

Continuation



Caution

Ensure that ALL the sealer residue is COMPLETELY removed off the cylinder head mating faces prior to installing the Guide plate -VAS 5161A/38-. If any sealer residue is left it will severely effect the removal and installation process of the valve keys.

Removal

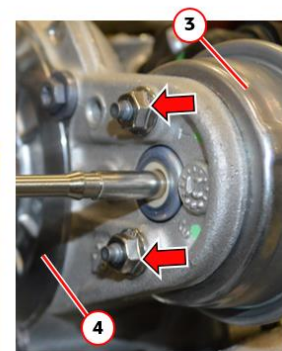
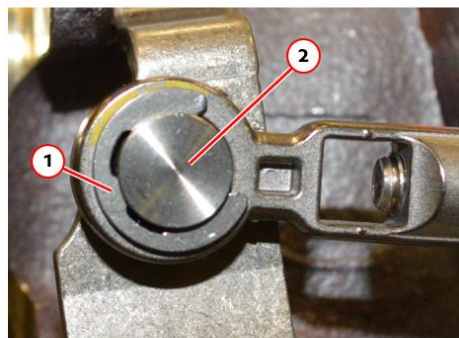
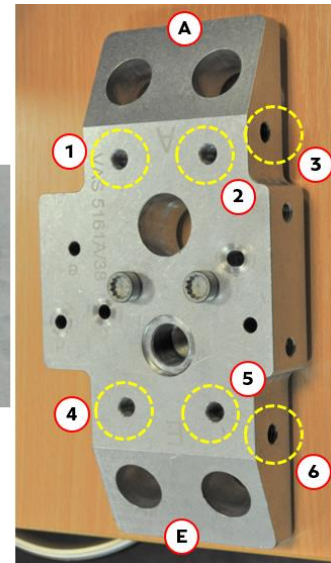
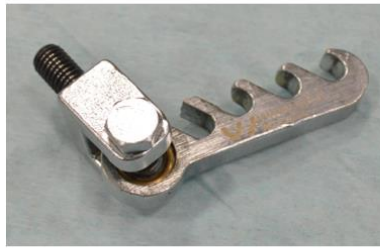

Install two M8x35 fixings -arrows- such as the ones from the "engine cross brace" (N 909 035 02), into the Guide plate -VAS 5161A/38- -1- by hand as shown. These fixings will act as dowels.

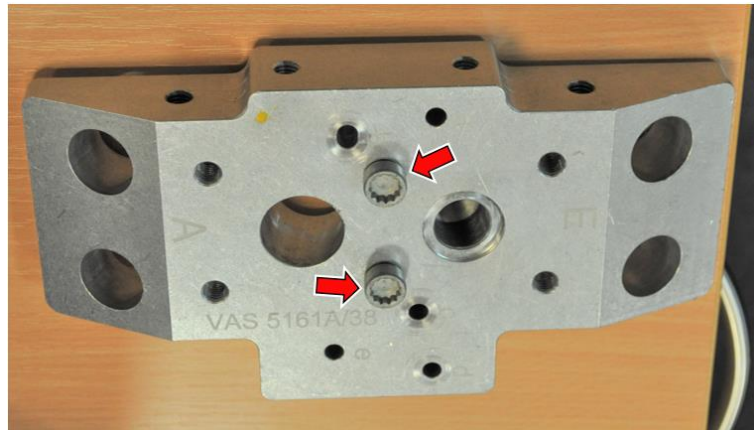

Install the Guide plate -VAS 5161A/38- -1- onto cylinder number one.

Image for illustration purposes only.

Insert two fixings -arrows- to secure the Guide plate -VAS 5161A/38- -1- to the cylinder head.



Note

Two coil pack fixings are ample in the securing of the Guide plate -VAS 5161A/38- to the cylinder head.

On cylinders "four" and "eight" only ONE fixing is used to secure the Guide plate -VAS 5161A/38- to the cylinder head.



Caution

RISK OF DEBRIS OR MATERIALS ENTERING THE ENGINE.

ENSURE that suitable steps are taken to protect any open ports or oil ways during this procedure!

Insert the punch -VAS 5161/3A- -2- from the tool set Removal and installation device for valve keys - VAS 5161A- in the guide plate and loosen any tight valve keys by tapping them "LIGHTLY " with a soft mallet.

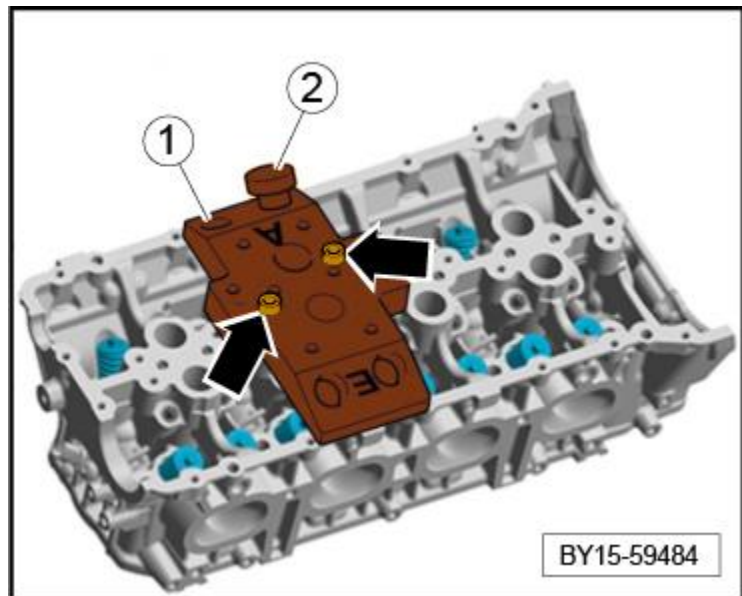

- Screw in the sealing pin -VAS 5161/10- -2- from tool set Removal and installation device for valve keys -VAS 5161A- into the Guide plate -VAS 5161A/38- by hand.

Image for illustration purposes only.

- Screw in the hose adapter -1- from a "Cylinder compression tester kit" hand-tight into the relevant cylinder spark plug thread.

- Connect the compressed air hose to the hose adapter -1- from the "Cylinder compression tester kit".

- Build up overpressure in the relevant combustion chamber.

⚠ WARNING

Compressed air is DANGEROUS! ENSURE that the correct personal protective equipment is worn during the use of compressed air.

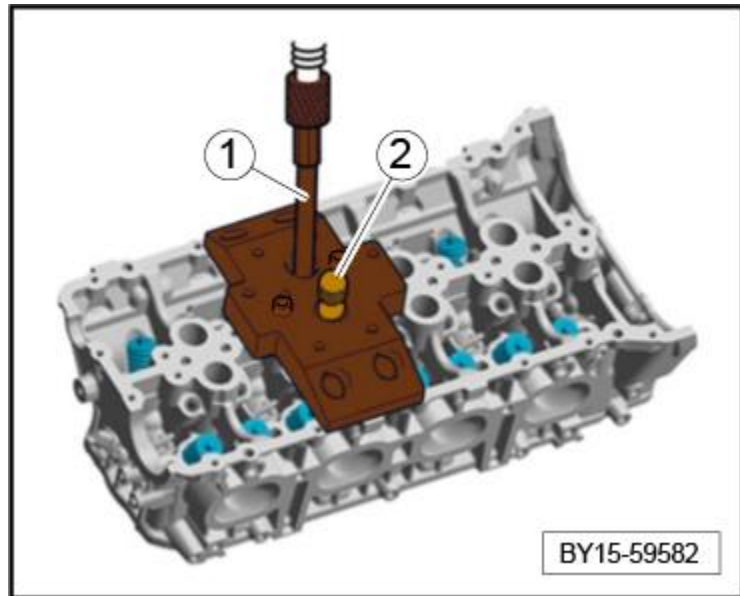

⚠ Caution

Ensure that the compressed air is operating at a minimum of "6 BAR " before continuing.

- Insert the Valve key cartridge -VAS 5161/8A- -4- into the Guide plate -VAS 5161A/38- onto the desired valve assembly.

Image for illustration purposes only.

- Follow the table for the correct positioning of the hook -VAS 5161/6- -2- and anchor -VAS 5161/5 M8- -3- for the removal of each valve set of valve keys.

- Engage the pressure fork -VAS 5161/2- -1- into the hook -VAS 5161/6- -2- and lever the Valve key cartridge -VAS 5161/8A- downwards until it touches the guide plate.

- While applying downward hand pressure to the pressure fork -VAS 5161/2-, turn the knurled screw -arrow- on the Valve key cartridge -VAS 5161/8A- back and forth to press the valve keys apart.

- Once the valve keys have successfully separated, the knurled screw -arrow- will move inwards on its own, and retain the valve keys within the Valve key cartridge -VAS 5161/8A- automatically.

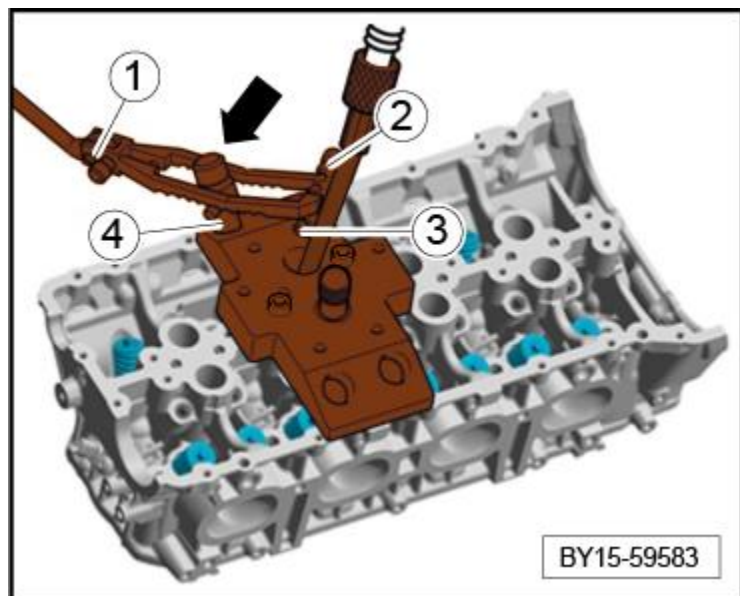

⚠ Caution

Do NOT touch the knurled screw on the Valve key cartridge -VAS 5161/8A- again until instructed.

Relieve the hand pressure from the fork -VAS 5161/2- -1- and remove Valve key cartridge -VAS 5161/8A- -4-.

Using a flexible magnet or by hand, remove the valve-spring cap -1- followed by the valve spring -2- then DISCARD the spring.

Installation of valve spring:



Caution

INLET AND EXHAUST VALVE SPRINGS ARE DIFFERENT! ENSURE that the CORRECT springs are fitted to the CORRECT valves. Refer to ETKA for the correct part numbers for Inlet and Exhaust springs.

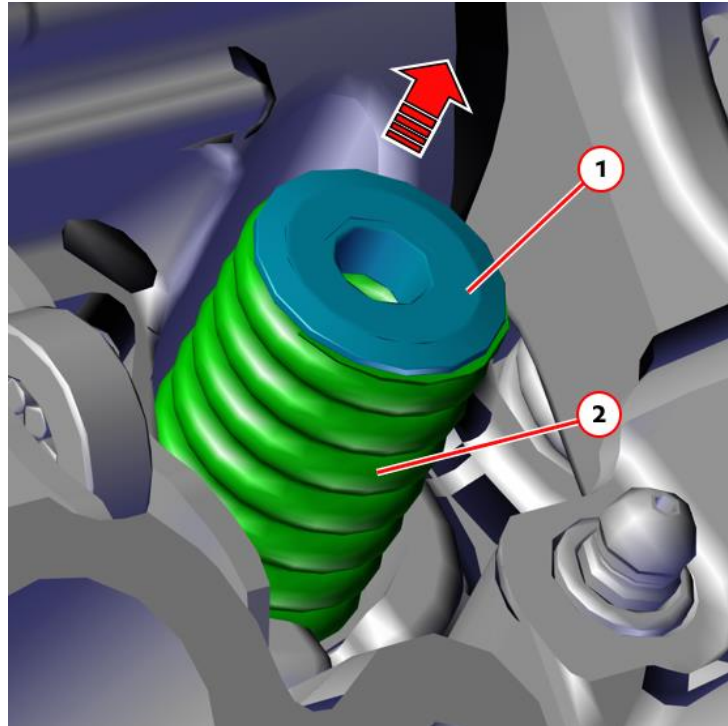

Care point.

Image for illustration purposes only.



Caution

All valve springs -1- (INLET and EXHAUST) MUST be installed with the tightest spring coils -highlighted- closest the cylinder head assembly -arrow-! Failure to adhere to this will cause catastrophic valve train failure.

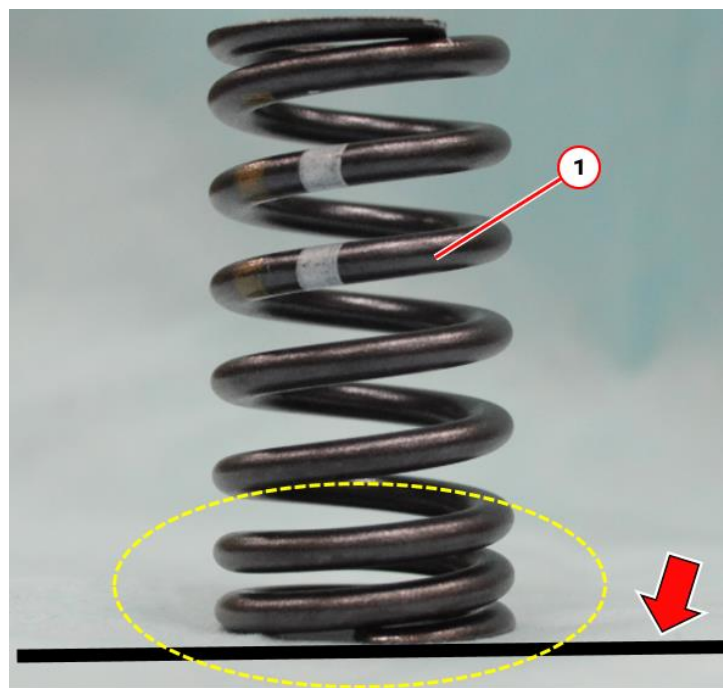

- Insert the NEW correct valve spring and valve-spring cap into position.

Image for illustration purposes only.

- Insert the Valve key cartridge -VAS 5161/8A- -4- into the Guide plate -VAS 5161A/38-.

- Engage the pressure fork -VAS 5161/2- -1- into the hook -VAS 5161/6- -2- and lever the Valve key cartridge -VAS 5161/8A- -4- downwards until it touches the guide plate.

- Pull the knurled screw -arrow- upwards on the Valve key cartridge -VAS 5161/8A-.

- Whilst still pulling up on the knurled screw, slowly release the pressure on the pressure fork -VAS 5161/2- -1-.

The valve keys are now secured on the valve stem.

- Fully remove the Valve key cartridge -VAS 5161/8A- from the Guide plate -VAS 5161A/38-.

- Perform a visual check, ensuring that both valve keys -1- are secured correctly to the valve stem -2- as shown.



Note

If the valve keys are not secured to the valve stem after the installation process, remove the valve keys and REPEAT the installation process until correct retention has been achieved.

- Repeat the procedure on each remaining valve.
- When all the valves are secured again, ONLY then can the compressed air connection be disconnect.
- Unscrew hose adapter from the spark plug hole.
- Continue this procedure on all remaining cylinders.

Installation

- Installation is the reverse of the removal procedure, noting the following.

Subsequent work

- Install the spark plugs. Refer to the relevant section of "Spark plugs to remove and refit"

→ Rep.-Gr.28

- Install the valve lifter (hydraulic tappet) and valve lever. Refer to

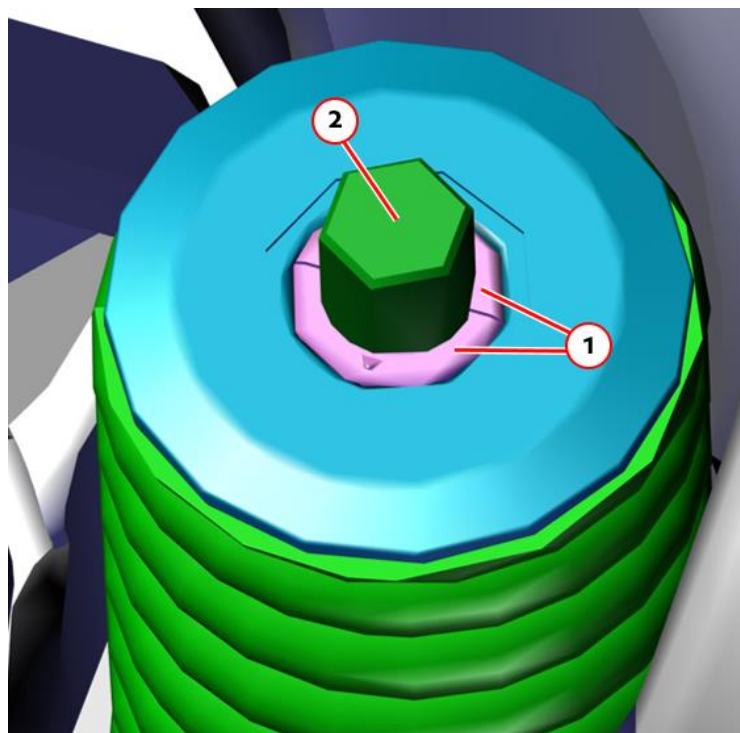
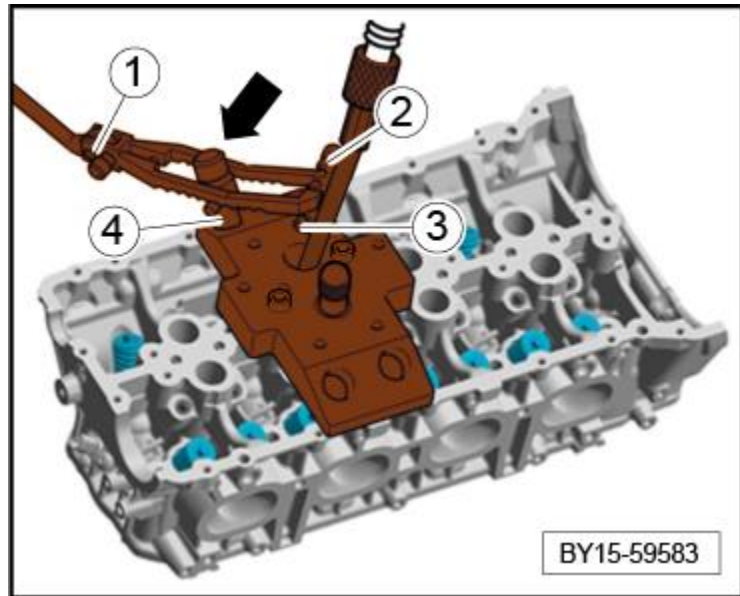

"Valve lifter (hydraulic tappet) – To remove and fit".

→ Rep.-Gr.15

PAGE LEFT INTENTIONALLY BLANK

1. Install spark plugs:

Special tools and workshop equipment required

Spark plug socket (14 mm) commercially available.

Installation

Installation is the reverse of removal procedure, noting the following:

- Torque tighten each spark plug to 23 Nm.



WARNING

Always fit a complete set of spark plugs of the same specification.

2. Install valve lifters (hydraulic tappets):

Installation

- Fit hydraulic tappet -2- on valve lever -3-.
- Position hydraulic tappet -2- and safety clip -1- on valve lever -3-.
- Insert hydraulic tappet -2- and hook safety clip -1- into valve lever -3-. Check that the safety clip -1- is fitted correctly.

- Fit hydraulic tappet -1- and valve lever -2-.
- Lightly lubricate the hydraulic tappet -1- and valve lever -2- with engine oil (0W-40).

- Insert hydraulic tappet -1- with the valve lever -2- into the cylinder head together.
- Position the pressure face of the valve lever -2- on the valve pressure face.
- After you have installed all hydraulic tappets and valve levers, check that they are fitted correctly.
- In particular, check that the safety clip is fitted correctly and that the pressure faces of the valve lever and valve are positioned correctly.

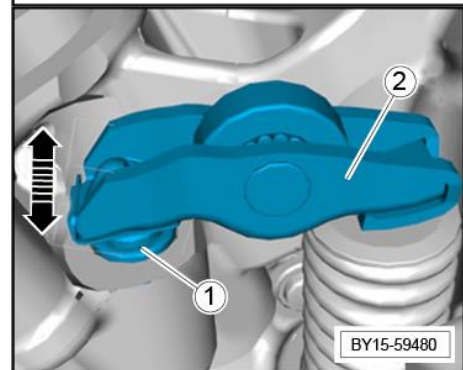
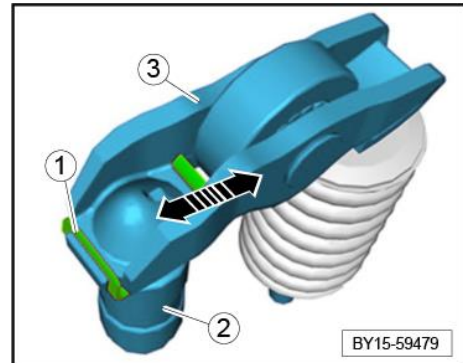

3. Install cylinder head covers:

The following procedure covers both bank 1 and bank 2 camshaft covers.

 Note

Cylinder heads are labelled Bank 1 (RHS) and Bank 2 (LHS) as viewed from the driver's seat.

Special tools and workshop equipment required

◆ Camshaft clamp kit -T40331-

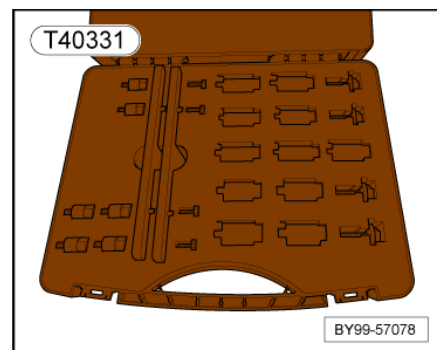

◆ Locating pins -T40116-

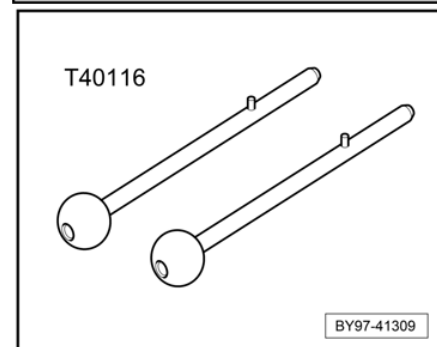

Installation

Installation is the reverse of removal, noting the following.

 Note

The Camshaft clamp -T40331- must be fitted before removal and installation.

→ Rep.-Gr.15

 Note

Fitting and sealing components using liquid sealant.

- ◆ Clean sealing faces to remove all traces of residual sealant (use a plastic scraper and scotch pads).

- ◆ Sealing faces must be free of grease and oil.
- ◆ Clean sealing faces with primer Loctite -7515-.
- ◆ Use liquid sealant Loctite -5970-BM-.

 **Caution**

The primer **MUST** be used prior to applying the sealant, failure to do so may result in oil leakage.

 **Note**

Before fitting the cylinder head cover, check that the rocker arms are aligned correctly.

- Apply liquid sealant Loctite -5970-BM- -1- on the cylinder head.

 **Note**

Install the cylinder head cover within five minutes of applying the liquid sealant.

- Fit and align cylinder head cover -1- on the cylinder head using Locating pins -T40116- -2-.

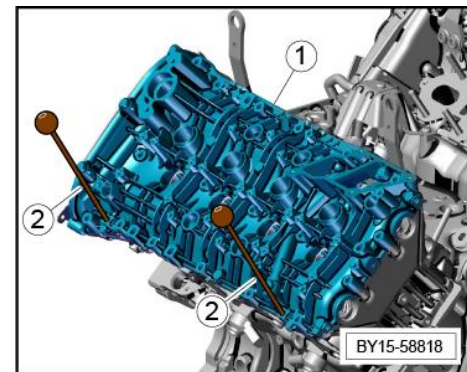
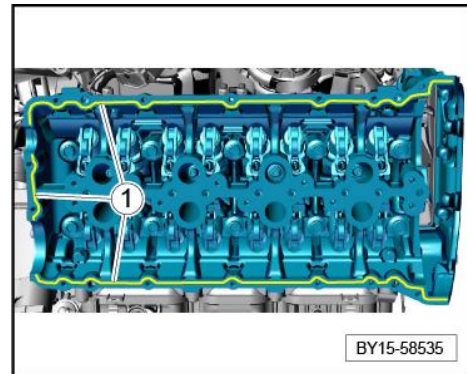

- Fit cylinder head cover.



Note

Top image – Bank 1 (RHS)

Bottom image – Bank 2 (LHS)

- Fit screws on the cylinder head cover uniformly and tighten according to the specified tightening sequence.

Torque tightening: 9 Nm

- Locating pins -T40116- must now be pulled off.

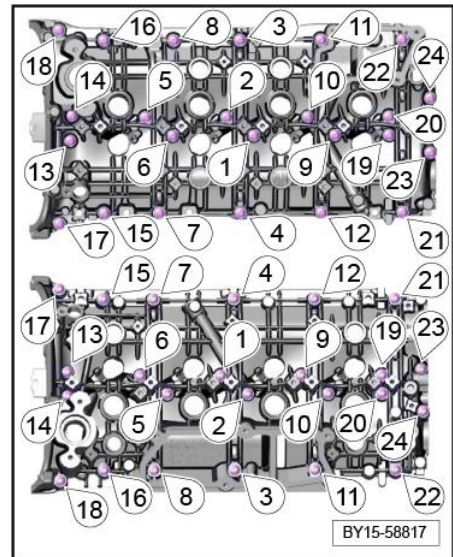

4. Install camshaft actuators (includes setting timing):

The camshaft actuators are located at the rear of cylinder banks 1 and 2, behind the upper chain housing covers.

WARNING

Before commencing work on and around the engine, ensure that it has cooled sufficiently, failure to do so may cause injury to personnel.

Avoid prolonged and repeated contact with oils and fluids etc.

- ◆ Always protect the skin with impervious gloves.
- ◆ Always wear suitable eye protection.

Caution

Suitably blank open ports to prevent the ingress of dirt, moisture and foreign objects into the engine. Failure to do so may cause irreparable damage to the engine.

Special tools and workshop equipment required

- ◆ Counter hold tool -T90001- (not illustrated)
- ◆ Ring wrench insert, a/f 41 -VAS 261 001- (not illustrated)
- ◆ Camshaft clamp -T40331-

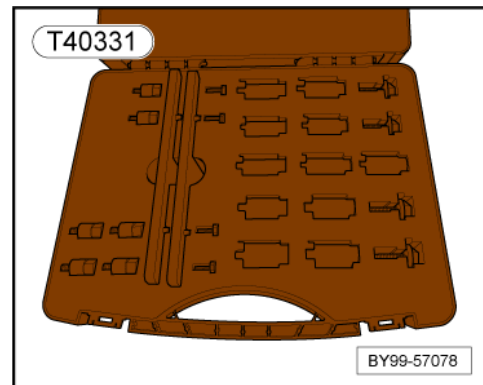

- ◆ Socket E24 -T90000- (not illustrated)
- ◆ Locking pin -T03006-
- ◆ Hook wrench -VAS 261 005- (not illustrated)
- ◆ Counterhold tool -T90002- (not illustrated)
- ◆ Vehicle tester

Component overview

Camshaft control

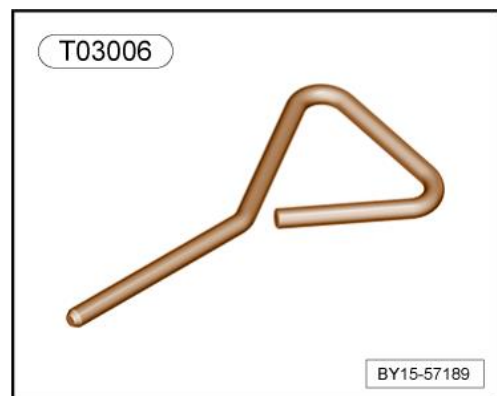

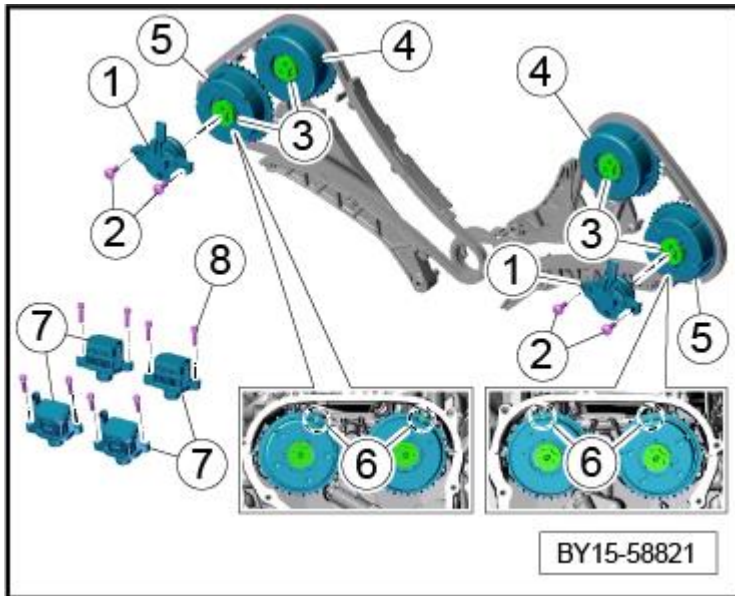

1 - Actuator for camshaft controller

2 - Screws, M6 x 16

Tightening torque: 9 Nm

3 - Central screw for camshaft controller

- ◆ Replace O-ring
- ◆ Initial tightening: 27 Nm
- ◆ Final tightening: 30 Nm +35°

4 - Actuator for outlet camshaft

5 - Actuator for intake camshaft

6 - Installation marking

7 - Valve lift adjustment

8 - Screw, M5 x 20

Tightening torque: 5 Nm

Tightening sequence for central screw for camshaft controller
(item -3-)

Result:	Cylinder bank:	Camshaft:
1.	Bank 2	Outlet
2.	Bank 2	Intake
3.	Bank 1	Intake
4.	Bank 1	Outlet

Installing camshaft actuators – setting the timing



Note

No TDC markings on cylinder head cover.

● In the event that there are no TDC markings on the cylinder head covers, raise a DISS query with Aftersales technical support.



Note

Camshaft actuator must not be disassembled!

Friction plate in camshaft actuator

- ◆ The camshaft actuator must never be disassembled.
- ◆ To replace the friction plate -1-, lever it out carefully using a small slotted screwdriver -2-.

– Check whether the crankshaft, the camshafts and the chain tensioners are fixed.

– Fit new friction plates between the camshaft actuators and camshaft stub.

– Allocate actuators to the camshafts. The actuator with the black surface is for the outlet side.

Distinguishing features of actuators

-1- Actuator for intake camshaft

-2- Actuator for exhaust camshaft

-3- TDC markings

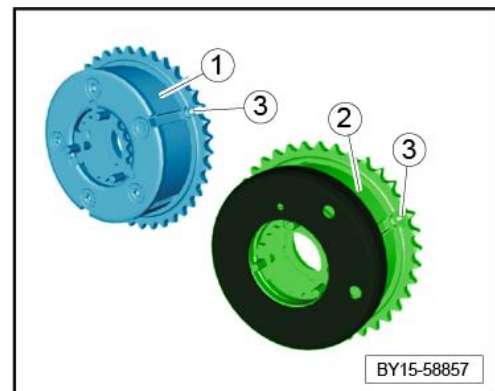
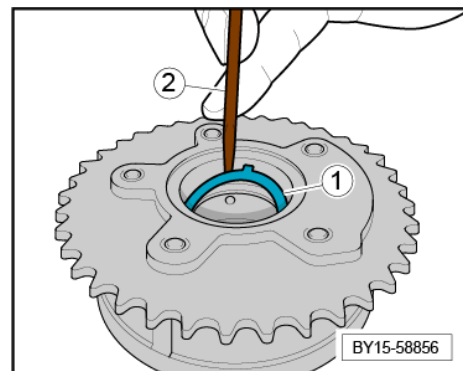

– Position the actuators on the camshafts and fit timing chain. Make sure that the markings on the actuators -1- match the cylinder head covers -2-.



Note

If there are no markings -2- on the cylinder head cover, raise a DISS query with Aftersales technical support.

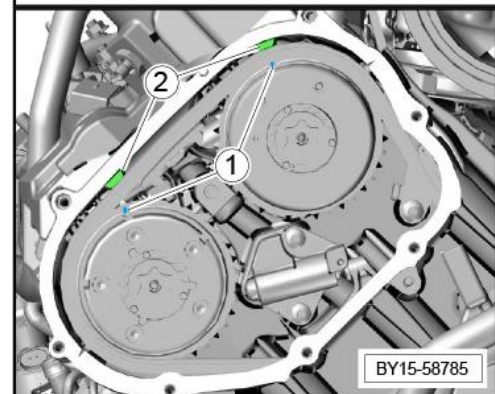

- Replace O-rings -1- on the central valves -2-.
- Lever out old O-ring -1- using a plastic wedge and dispose of it.
- Coat groove on central valve and new O-ring with oil.
- Carefully slide O-ring over the thread and shoulder -3- of the central valve and press it on using a plastic wedge.
- Do not use sharp-edged tools, such as a screwdriver.
- Never mask the thread with tape.
- Remove lock on the chain tensioner -3-.

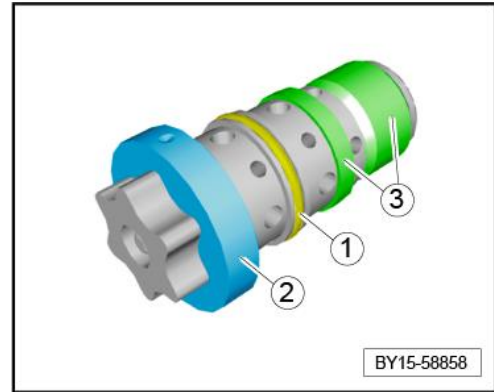

⚠ WARNING

If the tensioner pin is removed without chain guide lever in place, the piston & spring may fly out! (depending on version fitted).

- Screw in central valves.
- Pre-tension the timing chain and pre-tighten central valves.



⚠ Caution

Observe specified tightening sequence!

- 1. Outlet, cylinder bank 2
- 2. Intake, cylinder bank 2
- 3. Intake, cylinder bank 1
- 4. Outlet, cylinder bank 1

i Note

A second technician is advised when tightening the camshaft actuators.

Use Hook wrench -VAS 261 005- -1- to pre-tension the actuators anti-clockwise and use Socket E24 -T90000- -2- and a torque wrench -3- to pre-tighten the central valves.

Initial tightening: 27 Nm.

- Remove all staking tools.
- Camshaft clamp -T40331- and adapter can now be removed.

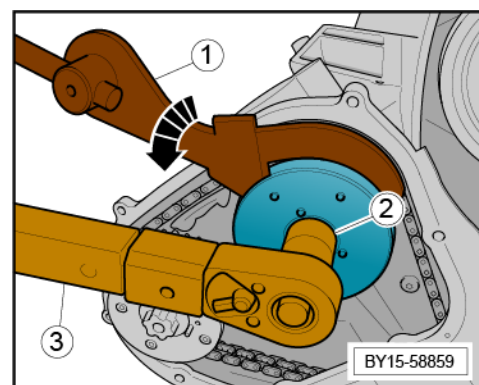

- The tool securing the crankshaft at the front of the engine can now be removed.

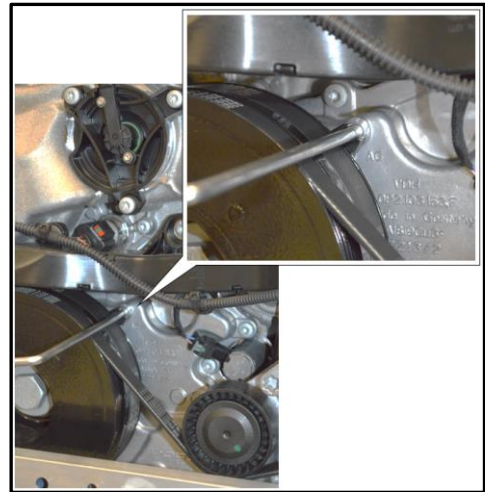

- Secure central valves.
- Counterhold tool -T90001- -1- and Counterhold tool -T90002- -2- must be fitted on the actuators. To do this, turn the engine clockwise until the tool engages.
- Tighten central valves using Socket E24 -T90000- -3-.
- ◆ Final tightening: 30 Nm.
- ◆ Final tightening: + 35°.

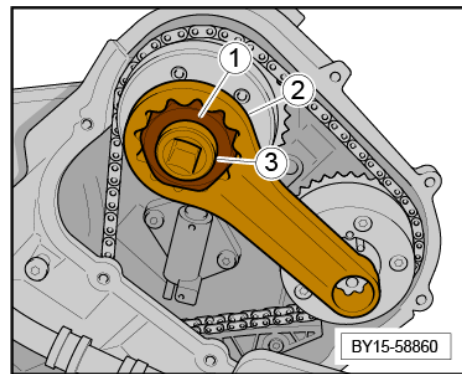

Subsequent work

- Fit change-over valve for water pump -3- and holder.
- Vacuum System for reference:
- 1- Brake booster vacuum pump
 - 2- Vacuum line
 - 3- Electric change-over valve for water pump
 - 4- Control valve for boost pressure control, cylinders 1 to 4
 - 5- Control valve for boost pressure control, cylinders 5 to 8
 - 6- Brake booster connection
 - 7- Vacuum unit connection
- Secure tank ventilation sensor (USA) or dummy (cylinders 1-4) -1-.
 - Position tank ventilation sensor (USA) or dummy -1- together with vent line -5- on holder -4-.
 - Screw in and tighten fastening screw -2-.
 - Plug in electric plug connection -3-.
 - For bank 2 only, fit the dipstick.

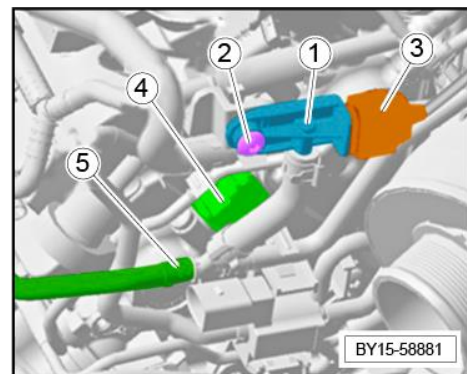
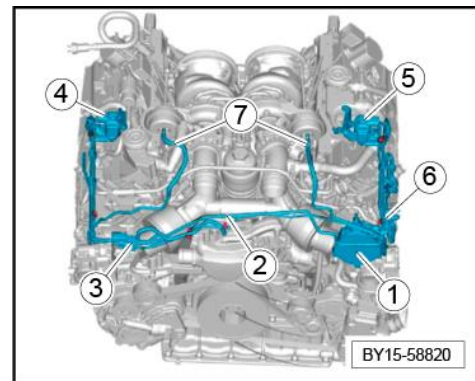

- Close off bearing tunnels with rubber caps. Exception: Left intake side with brake booster vacuum pump.

5. Install pressure pipes:

Special tools and workshop equipment required

- ◆ Hose clip pliers -ASE 451 492 00 000-.

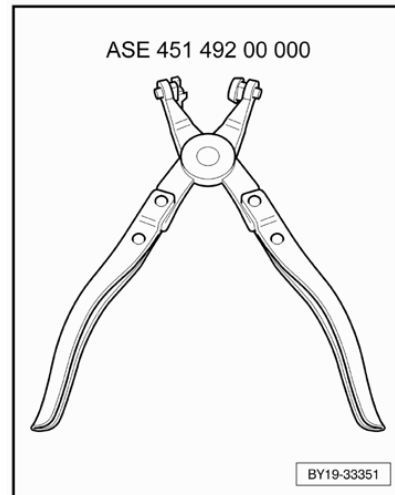

Installation

Installation is the reverse of removal procedure, noting the following.

- RENEW any "O-rings".
- Refit all previously removed components.
- Torque tighten all fixings as per removal.

–

→ Rep.-Gr.00

6. Install mechanical vacuum pump:

Installation

Installation is the reverse of removal procedure, noting the following.

- Ensure the mating faces between the vacuum pump and cylinder head are clean and free of dirt and residual oil.
- RENEW the "O-ring" -1- for the vacuum pump.

– Secure the vacuum pump to the cylinder head. Torque tighten the fixings in the sequence -1-3- as follows:

- ◆ Stage 1 — 5 Nm
- ◆ Stage 2 – 9 Nm

Drive gear

- Ensure that the drive gear in the camshaft -arrowed- aligns with the slot in the vacuum pump -arrowed-.

Camshaft keyway

Drive gear in vacuum pump

- Ensure all wiring and hoses are clipped in their original positions.

Torque tighten all remaining fixings.

–

→ Rep.-Gr.00

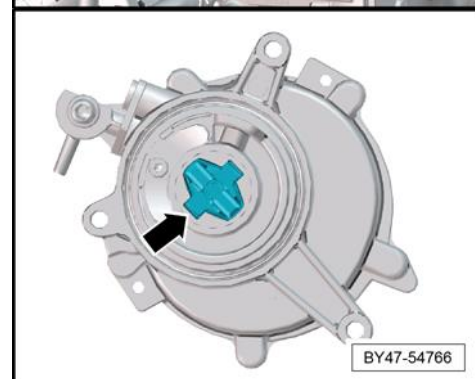
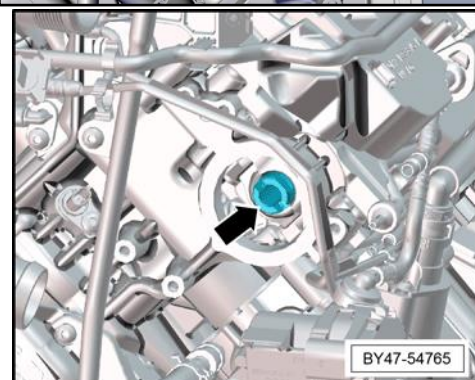
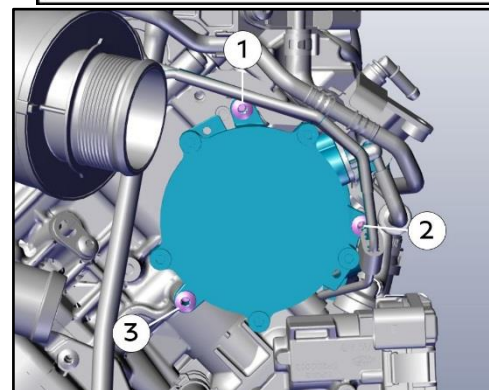
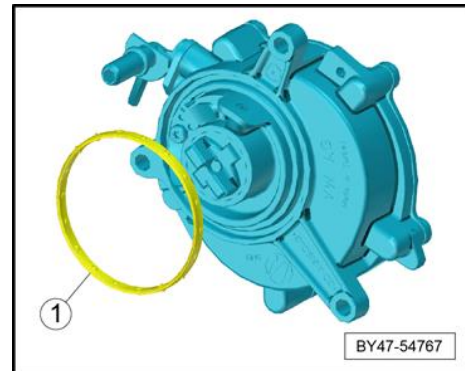

7. Install fuel injectors:

Special tools and workshop equipment required

Tool set for TSI engines -T10133-

Dismantling the injector

- Pull the O-ring -3- and spacer ring -2- off from the injector -1- and DISCARD.
- Remove items -5 & 7- and retain for refitment.
Carefully remove the old combustion chamber sealing ring -6- and DISCARD. To do so, very carefully cut the sealing ring with a knife or prise off with a suitable non-metallic tool.



Note

Take care not to damage the sealing groove on the injector. The injector must be renewed if the groove is damaged.

Installation

Installation is the reverse of removal procedure, noting the following.



Note

Renew combustion chamber ring -6-, seal and O-ring-3- and backing ring -2-.

Refit items -5 & 7-.

Renew spacer ring if damaged.

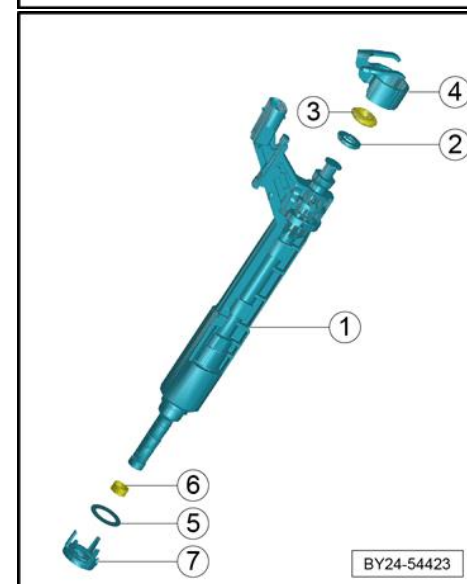
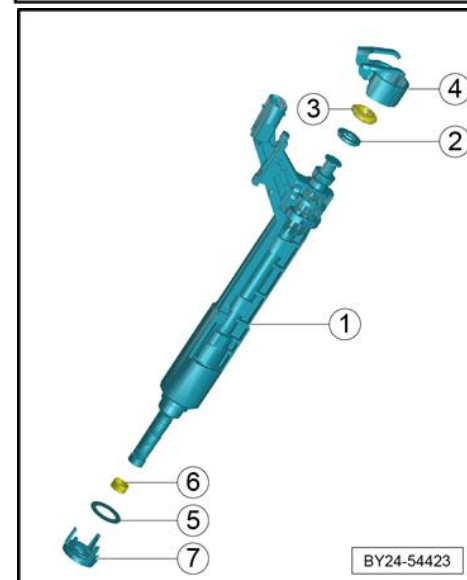
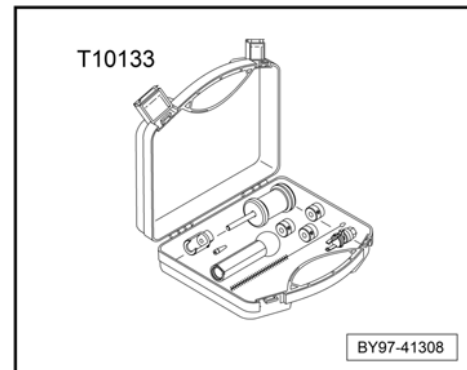

Lubricate O-rings of injectors lightly with clean engine oil.

- Clean the bore in cylinder head with Nylon cylinder brush -T10133/4-.
- Fit Assembly cone -T10133/5- with a NEW combustion chamber sealing ring -1- onto the injector -2-.

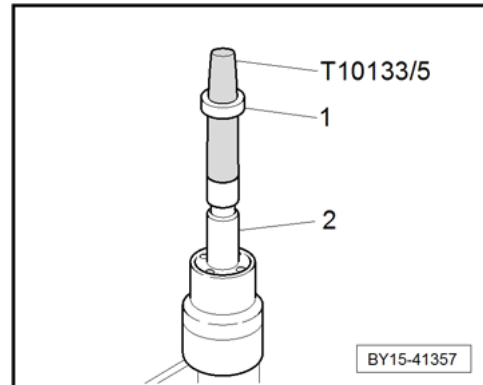

- Using the Assembly sleeve -T10133/6- push the combustion chamber sealing ring onto Assembly cone -T10133/5- as far as it will go.
- Turn around Assembly sleeve -T10133/6- and slide the combustion chamber sealing ring into the groove of the injector.

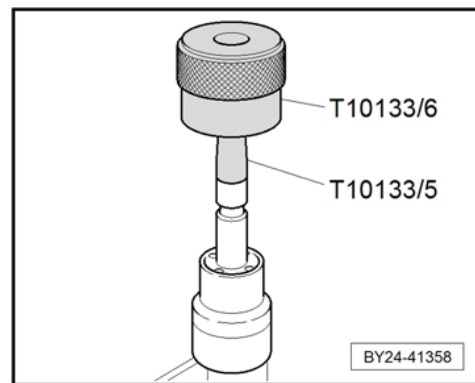

i Note

The combustion chamber sealing ring is widened when it is pushed onto the injector. After pushing it on, it therefore has to be compressed again. This is done in four stages, as described below.

- ◆ Push Calibration sleeve -T10133/7- onto the injector as far as it will go and simultaneously turn it 180°.
- ◆ Pull Calibration sleeve -T10133/7- off again by turning in the opposite direction.

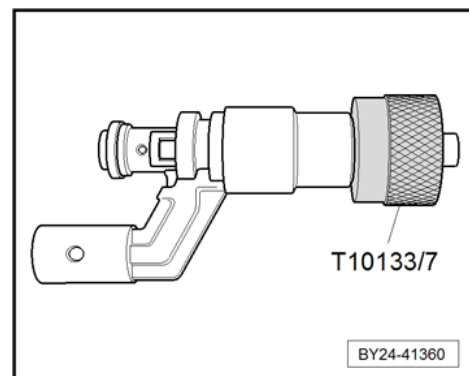

- ◆ Push Calibration sleeve -T10133/8- onto the injector as far as it will go and simultaneously turn it 180°.
- ◆ Pull Calibration sleeve -T10133/8- off again by turning in the opposite direction.

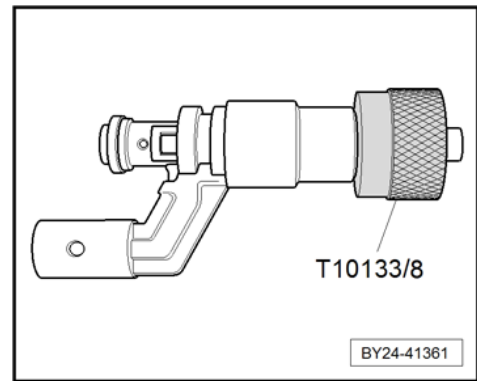

- Fit the parts from the injector repair kit onto the injector - 1-:
- To ease injector installation into the fuel rail, lubricate new O-ring lightly with clean engine oil before installing it.

i Note

The combustion chamber ring seal -6- must NOT be lubricated.

! *Caution*

Use Press tool -T10133/9-, push the injector into the cylinder head as far as it will go. DO NOT push the injector in by force.

- Replace all previously discarded parts.
- Replace low pressure injector O rings and the fuel supply pipes and clamps.

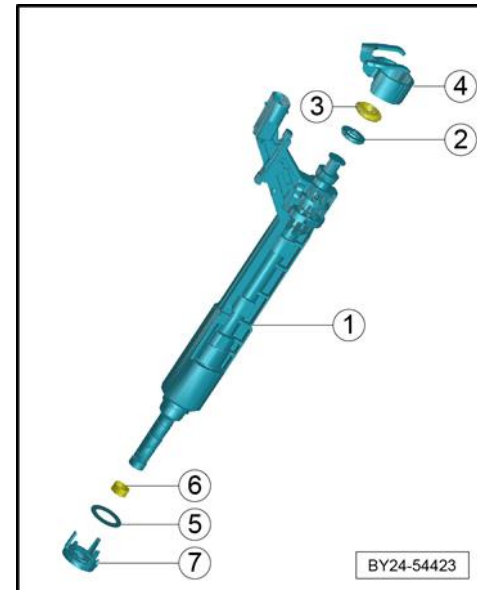

8. Install cylinder deactivation solenoids:

Installation

Installation is the reverse of removal procedure, noting the following.

- RENEW the "O-rings" on the cylinder deactivation solenoids.
- Before refitting the solenoids, apply a small amount of CLEAN engine oil to the "O-ring".
- Torque tighten all fixings as per removal.
- [→ Rep.-Gr.00](#)

9. Install fuel rails:

The installation of the fuel rails is symmetrically the same on both banks of the engine unless stated otherwise.

Installation

Installation is the reverse of removal procedure, noting the following.

- Torque tighten the fixings in the sequence shown.
- ◆ Stage 1 — Hand tight.
- ◆ Stage 2 — 7 Nm.
- ◆ Stage 3 — 10 Nm.

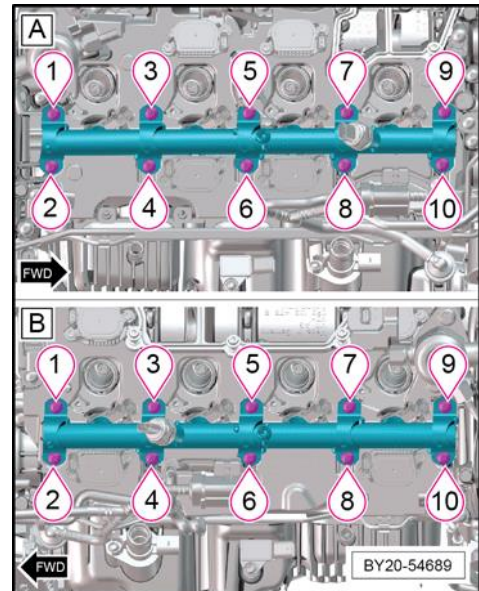

10. Install high pressure fuel pumps:

The installation of the high pressure fuel pump is the same for both sides of the engine unless stated otherwise.

Special tools and workshop equipment required

- ◆ Torque wrench -VAG 1331 -

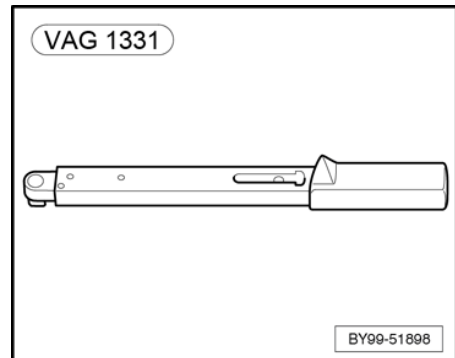

- ◆ Tool insert AF 17 -VAG 1331/6-

Consumables

Microgleit DF977S lubricant (refer to electronic parts catalogue "ETKA")

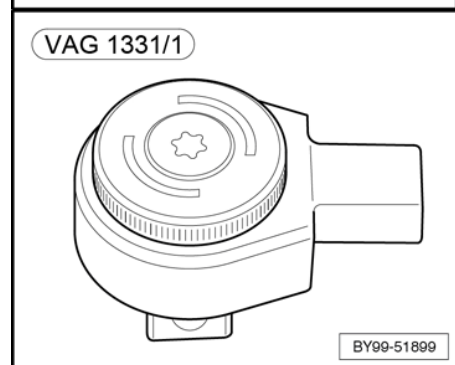

Installation

Installation is the reverse of removal procedure, noting the following.

- Lightly lubricate roller tappet with engine oil (0W-40) and insert it so that the lug -arrow A- slides into the guide notch. -arrow B-

- Using a suitable "breaker" bar, rotate the engine in the direction of normal engine rotation and at the same time press the roller tappet into the camshaft cover until it reaches its lowest point.

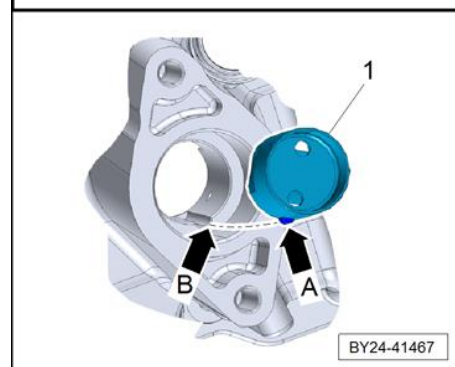

- Fit the high pressure pump into the camshaft cover making sure that a NEW O-ring is fitted.

 **Caution**

When installing the fixings -3- for the high pressure pump, first fit them by hand.

When first installed, the high pressure pump will protrude from the camshaft cover, therefore the following tightening procedure MUST be adhered to.

Stage 1 — Sequentially hand tighten the fixings -3- two turns at a time until the pump contacts the mating face to prevent damage to the internal spring in the high pressure pump.

- ◆ Stage 2 — Torque tighten to 12 Nm.
- ALWAYS lubricate the fuel pipe threads with Microgleit DF977S lubricant prior to fitting.

Torque tighten all remaining fixings.

-
- → Rep.-Gr.00
- Upon completion check for leaks.

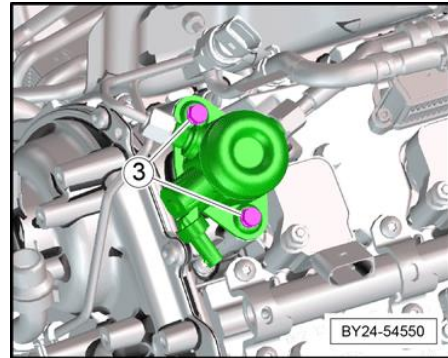

11. Install high-pressure fuel lines, banks 1 and 2:

Special tools and workshop equipment required

- ◆ Torque wrench -VAG 1331 -

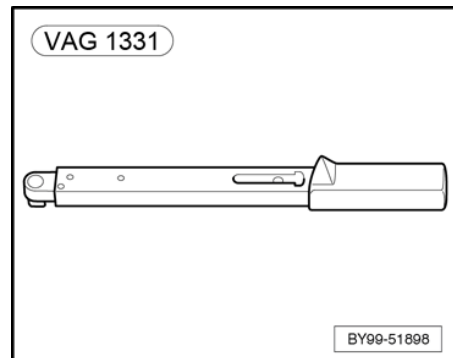

- ◆ Tool insert AF 17 -VAG 1331/6-

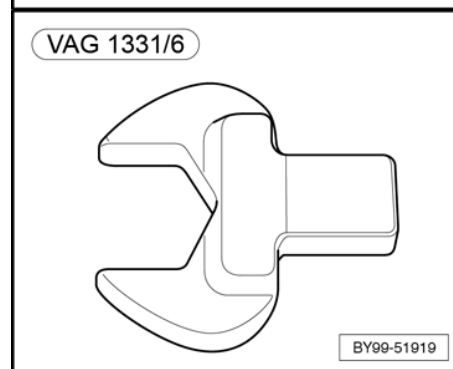

Consumables

Microgleit DF977S lubricant (refer to electronic parts catalogue "ETKA")

Installation

Installation is the reverse of removal procedure, noting the following.

- Bank 1

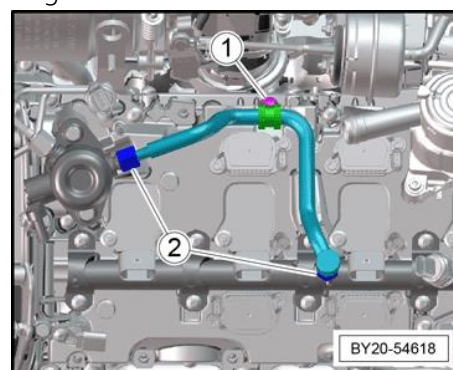

- Bank 2
- ALWAYS lubricate the union threads -2- with Microleite DF977S lubricant prior to fitting.

The following procedure must be followed to ensure the high pressure fuel pipes are correctly tightened to eliminate the risk of fuel leaks.

Fit the fixing for the fuel pipe clamp first onto the cylinder head BEFORE tightening the high pressure fuel pipes. Do

- not tighten until the fuel pipes have been torque tightened.

 Note

Hand tighten the high pressure fuel pipe unions before torque tightening. Ensure the pipes are stress free before tightening.

Fit the fuel rail union first, then fit the high pressure fuel pump union.

Using the Torque wrench -VAG 1331 - and Tool insert AF

- 17 -VAG 1331/6- torque the high pressure fuel pipes -2- to the following torque.
- ◆ Stage 1 — Hand tighten.
- ◆ Stage 2 — 8 Nm.
- ◆ Stage 3 — + 50°.

 **Caution**

During the torque tightening procedure, ensure the fuel pipe remains central inside the union. Failure to do so may cause damage to the brass fitment seal and cause a fuel leak.

- Refit all previously removed components.
- Torque tighten all remaining fixings.

→ Rep.-Gr.00

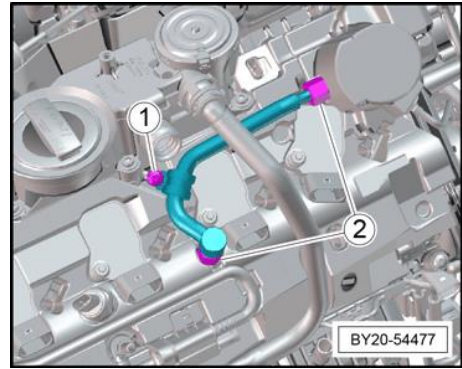

12.Install ignition coils:

Consumables

Silicone paste -G052565A1- (refer to ETKA)

Installation

Installation is the reverse of removal procedure, noting the following.

- Apply Silicone paste -G052565A1- to the area shown - arrow- prior to refitting the ignition coils.
- Push the ignition coils fully home to the abutment with the camshaft cover face.
- Ensure the correct electrical connector is fitted to each ignition coil.

Torque tighten all remaining fixings.

-

→ Rep.-Gr.00

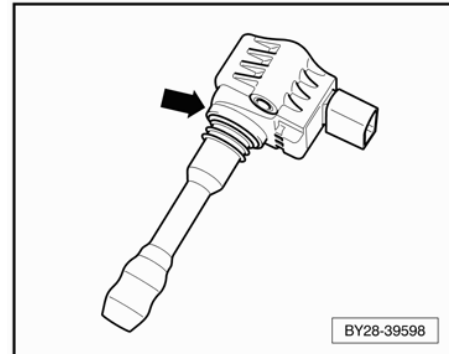

13. The following is applicable to both oil mist separators.

Installation

Installation is the reverse of removal procedure, noting the following.

- RENEW the seal.
- Refit all previously removed components.

Torque tighten all remaining fixings.

–

→ Rep.-Gr.00

14. Install upper chain housing covers:

Installation



Note

Fitting and sealing components using liquid sealant.

- ◆ Clean sealing faces to remove all traces of residual sealant.
- ◆ Sealing faces must be free of grease and oil.
- ◆ Clean sealing faces with primer Loctite -7515-.
- ◆ Use liquid sealant Loctite -5970-BM-.



Caution

The primer **MUST** be used prior to applying the sealant, failure to do so may result in oil leakage.

– Apply liquid sealant Loctite -5970-BM- -arrow- on the chain housing cover.

– Install the chain housing cover within 5 minutes of applying the liquid sealant.

- Install chain housing cover -1-.
- Fit chain housing cover -1- on cylinder head.
- Fit and tighten screws -2- (9 Nm) uniformly.

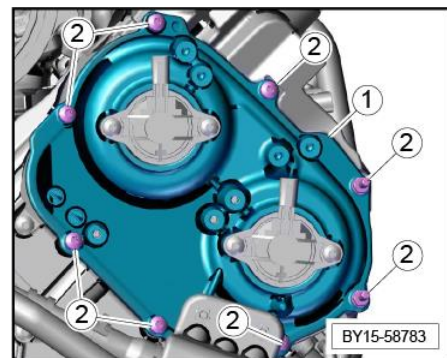
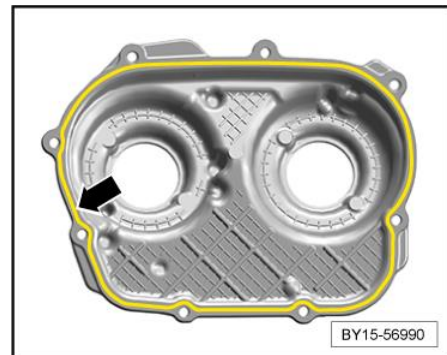

15. Install rear high-pressure fuel line:

Special tools and workshop equipment required

- ◆ Torque wrench -VAG 1331 -
- ◆ Tool insert AF 17 -VAG 1331/6-

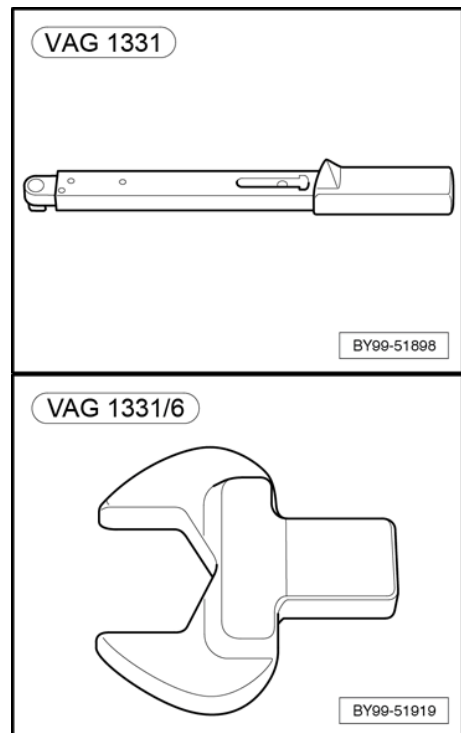

Consumables

Microlelit DF977S lubricant (refer to electronic parts catalogue "ETKA")

Installation

Installation is the reverse of removal procedure, noting the following.

- On both sides, lubricate the union threads -4- with Microlelit DF977S lubricant prior to fitting the link pipe.



Note

Hand tighten the high pressure fuel pipe unions before torque tightening. Ensure the pipes are stress free before tightening.

- Using Torque wrench -VAG 1331 - and Tool insert AF 17 - VAG 1331/6-, torque tighten the union fittings -4- to 8 Nm + 50°.



Caution

During the torque tightening procedure, ensure the fuel pipe remains central inside the union. Failure to do so may

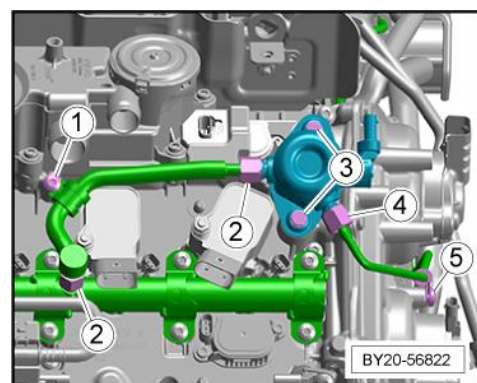

cause damage to the brass fitment seal and cause a fuel leak.

- Fit NEW O-rings to the coolant pipes.

- Torque tighten all remaining fixings.

→ Rep.-Gr.00