

<b>REFERENCE:</b>	Nova Bus Manuals
<b>SECTION:</b>	04: Suspension
<b>RS N°:</b>	MQR 7621-2202
<b>EFFECTIVE IN PROD.:</b>	NA

<b>APPLICATION DEADLINE:</b> N/A
----------------------------------

<b>SUBJECT:</b>	ZF/Sachs Shock mount design improvement.
<b>JUSTIFICATION:</b>	New lower shock mount available with an adapter plate better suited for the front and rear axle.

LEVEL	DESCRIPTION	DIRECT CHARGES		TIME
		LABOUR	MATERIAL	
1	Replacement of lower shock mount (per shock).	Client	Client	0.25 hr
2	-	-	-	-

**MATERIAL**

QTY	PART N°	REV.	DESCRIPTION
<b>LEVEL 1</b>			
6	630255	-	Lower Shock Kit
<b>LEVEL 2</b>			
-	-	-	-
<b>SHOP SUPPLY</b>			
-	-	-	-

To order, please contact novabus.parts@volvo.com Or by phone for CANADA 1-800-771-6682, for USA 1-877-999-8808 Specify document number, quantity of parts required and shipping address.

**DISPOSAL OF PARTS**

<b>REMOVED PARTS ARE:</b>	<b>DISCARDED*</b>	<b>RETAINED</b>	* Dispose of the unused parts and the defective parts in accordance with local environmental standards in effect.
	Yes	-	

**REVISION HISTORY**

REV.	DATE	CHANGE DESCRIPTION	WRITTEN BY
NR	2022FE07	Initial release	Devanand

CLIENT	ORDER	ROAD NUMBER		VIN (2NVY/4RKY...)		QTY
		FROM	TO	FROM	TO	
Academy Bus - New Jersey	L231	—	—	L82U563000166	L82U163000178	13
Academy Bus - New Jersey	L333	—	—	L82U273000207	L82U473000211	5
Academy Bus - New Jersey	L339	—	—	L82U483000047	L82U883000052	5
Academy Bus - New Jersey	L340	—	—	L82U493000003	L82U193000007	5
Academy Busline - New Jersey	LA13	—	—	L82J4G9775611	L82J5G9775620	10
Academy Busline - New Jersey	LC95	—	—	L82J2L9777559	L82J9L9777560	2
Airdrie Transit - Alberta	L664	—	—	L82U2B3000507	L82U2B3000507	1
Airdrie Transit - Alberta	L759	—	—	L82U0D3000928	L82U0D3000928	1
Airdrie Transit Alberta	LB10	3718	3718	L82J1J9776464	L82J1J9776464	1
Airdrie Transit Alberta	LC17	3725	3726	L82J3K3751850	L82J5K3751851	2
Ames Transportation Agency - Iowa	L707	660	661	S92U5C4500159	S92U1C4500160	2
Ames Transportation Agency - Iowa	L904	6101	6104	S92J1G9775221	S92J7G9775224	4
Arrow Coach Line - Arkansas	L252	—	—	L82U963000235	L82U963000235	1
Arrow Coach Line - Arkansas	L494	—	—	L82U793000397	L82U793000397	1
Austin - CMTA - Texas	L635	5001	5001	S92U7C4500163	S92U7C4500163	1
Austin - CMTA - Texas	L636	5002	5022	S92U1D4500306	S92U0D4500328	21
Austin - CMTA - Texas	L704	5051	5068	L82J7E4500471	L82J2E4500488	18
Austin - CMTA - Texas	LA17	5101	5107	S92J2H9775763	S92J3H9775769	7
Austin - CMTA - Texas	LA18	5151	5158	L82J0H9775770	L82J3H9775777	8
Barrie Ontario - Metrolinx	L878	1501	1504	L82JXF3001691	L82J6F3001719	4
Barrie Ontario - Metrolinx	L955	1601	1604	L82J7G9775408	L82J9G9775412	4
Barrie Ontario - Metrolinx	LA31	1701	1705	L82J0H9775817	L82J2H9775821	5
Barrie Ontario - Metrolinx	LA49	1706	1713	L82J7H3750855	L82J4H3750862	8
Barrie Ontario - metrolinx	LC63	2001	2002	L82J3L9777537	L82J5L9777538	2
BC Transit - BCT - British Columbia	L215	9201	9210	L82U663000001	L82U763000010	10
BC Transit - BCT - British Columbia	L236	9211	9231	L82U063000141	L82U663000161	21
BC Transit - BCT - British Columbia	L342	9232	9251	L82U173000294	L82U173000313	20
BC Transit - BCT - British Columbia	L343	9252	9267	L82U973000463	L82U073000478	16
BC Transit - BCT - British Columbia	L414	9268	9289	L82U983000299	L82U783000320	22
BC Transit - BCT - British Columbia	L417	9290	9297	L82U983000321	L82U183000328	8
BC Transit - BCT - British Columbia	L430	9301	9318	L82U483000503	L82U483000520	18
BC Transit - BCT - British Columbia	L458	9298	9300	L82U683000521	L82UX83000523	3
BC Transit - BCT - British Columbia	L463	9319	9333	L82U093000273	L82U093000287	15
BC Transit - BCT - British Columbia	L481	9334	9353	L82U794000004	L82U094000023	20
BC Transit - BCT - British Columbia	L486	9354	9369	L82U294000024	L82U494000039	16
BC Transit - BCT - British Columbia	L484	9370	9403	L82U494000090	L82U494000123	34
BC Transit - BCT - British Columbia	L487	9404	9433	L82U094000149	L82U794000178	30
BC Transit - BCT - British Columbia	L604	9434	9434	L82U5C3000597	L82U5C3000597	1
BC Transit - BCT - British Columbia	L735	9435	9440	L82U4C3000848	L82U8C3000853	6
BC Transit - BCT - British Columbia	L736	9441	9446	L82U8D3000854	L82U7D3000859	6
BC Transit - BCT - British Columbia	L858	9447	9481	L82JXE3001401	L82J5F3001436	35

CLIENT	ORDER	ROAD NUMBER		VIN (2NVY/4RKY...)		QTY
		FROM	TO	FROM	TO	
BC Transit - BCT - British Columbia	L891	—	—	L82J5F3001565	L82J2F3001569	5
BC Transit - BCT - British Columbia	LA16	6000	6029	L82J3H9776217	L82J4H9776307	30
Belleville Ontario (ref. L962)	L840	8092	8092	L82J9E4500715	L82J9E4500715	1
Belleville Transit - Ontario	L180	180-1	180-1	L82U753000118	L82U753000118	1
Belleville Transit - Ontario	L176	—	—	L82U563000233	L82U563000233	1
Belleville Transit - Ontario	L354	354-1	354-1	L82U983000089	L82U983000089	1
Belleville Transit - Ontario	L357	357-1	357-1	L82U783000091	L82U783000091	1
Belleville Transit - Ontario	L542	—	—	L82UXA3000088	L82U8A3000090	3
Belleville Transit - Ontario	L598	—	—	L82U5A3000581	L82U7A3000582	2
Belleville Transit - Ontario	L655	—	—	L82U3B3000385	L82U3B3000385	1
Belleville Transit - Ontario	L702	—	—	L82U4D3000706	L82U4D3000706	1
Bow Valley Transit - Alberta	L347	1	4	L82W083000175	L82W683000178	4
Bow Valley Transit - Alberta	LB86	N/A	N/A	L82J8K9777001	L82J1K9777003	3
Bow Valley Transit - Alberta	L712	5	6	L82U6C3000804	L82U8C3000805	2
Bow Valley Transit - Alberta	L993	—	—	L82JXG3750329	L82J6G3750330	2
Bow Valley Transit - Alberta	LA26	—	—	L82J4H3750473	L82J4H3750473	1
Bow Valley Transit - Alberta	LA28	—	—	L82J6H9776308	L82J4H9776310	3
Brampton - Ontario	L209	0601	0621	L82U253000222	L82U853000242	20
Brampton - Ontario	L238	0609	0609	L82U663000094	L82U663000094	1
Brampton - Ontario	L253	0622	0632	L82U463000269	L82U763000279	11
Brampton - Ontario	L284	0633	0638	L82U363000280	L82U263000285	6
Brampton - Ontario	L348	0701	0715	L82U273000479	L82U773000493	15
Brampton - Ontario	L349	0801	0810	L82U283000094	L82UX83000103	10
Brampton - Ontario	L424	0811	0827	L82U783000463	L82U083000479	17
Brampton - Ontario	L425	0901	0916	L82U993000045	L82U593000060	16
Brampton - Ontario	L501	0917	0926	L82U893000506	L82U893000523	10
Brampton - Ontario	L789	1401	1408	L82J4E3001216	L82J1E3001223	8
Brampton - Ontario	L816	1409	1415	L82J3E3001224	L82J9E3001230	7
Brampton - Ontario	L864	1501	1510	L82JXF3001500	L82J6F3001509	10
Brampton - Ontario	L865	1511	1519	L82JXF3001514	L82J9F3001522	9
Brampton - Ontario	L942	1601	1613	L82J6G3750070	L82J4G3750083	13
Brampton - Ontario	L941	1614	1623	L82J1G3750123	L82J2G3750132	10
Brampton - Ontario	LA20	1707	1713	L82J5H3750532	L82J6H3750538	7
Brampton - Ontario	LA21	1701	1706	L82J8H3750539	L82J1H3750544	6
Brampton - Ontario	LB01	1801	1817	L82J3H3750948	L82J6J3750982	17
Brampton - Ontario	LB02	1818	1823	L82J3J3751121	L82J2J3751126	6
Brampton Ontario	LC23	1901	1907	L82J3K3751878	L82J9K3751884	7
Brampton Ontario	LC54	1908	1916	L82J0K3751885	L82JXK3751893	9
Brampton Ontario	LD18	2007	2024	L82J5L3752614	L82J5L3752631	18
Brandon - Manitoba	L899	67	70	L82J2G3750180	L82J8G3750183	4
Brantford - Ontario	L256	—	—	L82U363000229	L82U363000229	1

CLIENT	ORDER	ROAD NUMBER		VIN (2NVY/4RKY...)		QTY
		FROM	TO	FROM	TO	
Brantford - Ontario	L257	—	—	L82UX63000230	L82UX63000230	1
Brantford - Ontario	L258	—	—	L82U163000231	L82U163000231	1
Brantford - Ontario	L175	—	—	L82U363000232	L82U363000232	1
Brantford - Ontario	L351	9071	9075	L82U883000018	L82UX83000022	5
Brantford - Ontario	L422	9081	9084	L82U183000524	L82U783000527	4
Brantford - Ontario	L547	10101	10105	L82X6A3000082	L82X3A3000086	5
Brantford - Ontario	L663	10121	10121	L82U1B3000532	L82U1B3000532	1
Brantford - Ontario	L718	10123	10125	L82U5C3000826	L82U9C3000828	3
Brantford - Ontario	L775	10131	10132	L82U1D3000999	L82U2D3001000	2
Brantford - Ontario	L928	10151	10153	L82J7F3001793	L82J0F3001795	3
Brantford - Ontario	LA03	10161	10612	L82J0G3750369	L82J7G3750370	2
Brantford - Ontario	LB64	101808	101810	L82J2J3751465	L82J6J3751467	3
Buffalo New York - NFTA	LC12	1901	1923	L82K6K9777345	L82K8K9777377	23
Buffalo New York - NFTA - CNG	LB22	1801	1816	L82KXJ9776486	L82K1J9776506	16
Burlington - Ontario	L887	7017-15	7025-15	L82J7F3001681	L82J8F3001723	9
Burlington - Ontario	LB35	7033-18	7036-18	L82J9J3751432	L82J0J3751433	2
Burlington Ontario - metrolinx	LC18	1901	1907	L82J9K3752095	L82J0K3752101	7
Calgary Transit - Alberta	L601	8101	8114	L82U5A4000099	L82U4A4000112	14
Calgary Transit - Alberta	L607	8115	8130	L82UXA3000477	L82U6A3000492	16
Calgary Transit - Alberta	L615	8131	8158	L82U1B4000019	L82U4B4000046	28
Calgary Transit - Alberta	L624	—	—	L82U4B4000077	L82U6B4000078	2
Calgary Transit - Alberta	L637	8161	8180	L82U7B3000356	L82U2B3000376	20
Calgary Transit - Alberta	L709	8181	8200	L82UXC3000806	L82U3C3000825	20
Calgary Transit - Alberta	L733	8201	8202	L82AXD3000926	L82A1D3000927	2
Calgary Transit - Alberta	LB85	8355	8362	L82K9J9776916	L82K6J9776923	8
Calgary Transit - Alberta	LB91	8363	8394	L82K3K9777030	L82K1K9777074	32
Calgary Transit - Alberta	LC69	8395	8434	L82K2K9777388	L82K8K9777427	40
Calgary Transit - Alberta	LC94	8435	8464	L82K5L9777497	L82K8L9777526	30
Cape Breton Nova Scotia	LA12	7092	7093	L82J8H3750587	L82JXH3750588	2
Cape Breton Nova Scotia	LB92	7112	7113	L82J3K3751766	L82J5K3751767	2
Cape Breton Nova Scotia	LC90	—	—	L82J1L3752383	L82J1L3752383	1
Capital Area Rural Transportation System (CARTS)	L980	—	—	L82J1G9775565	L82J9G9775569	3
Capital Area Transportation Authority Michigan - CATA	LC07	6012	6015	S92J5K9777269	S92J5K9777272	4
Capital Area Transportation Authority Michigan - CATA	LC08	700	718	L82J7K9777278	L82J8K9777306	19
CHARM city Baltimore - Maryland	LC73	1910218	1910223	L82J4K9777447	L82J8K9777452	6
Chicago Transit Authority - CTA - Illinois	L773	—	—	L82JXD4500429	L82J6D4500430	2
Chicago Transit Authority - CTA - Illinois	L811	7902	7949	L82J6E4500509	L82J4E4500556	48
Chicago Transit Authority - CTA - Illinois	L837	7950	7999	L82J6E4500655	L82J1E4500708	50
Chicago Transit Authority - CTA - Illinois	L847	8000	8049	L82J1E4500773	L82JXE4500822	50
Chicago Transit Authority - CTA - Illinois	L848	8050	8099	L82JXF4500823	L82J1F4500872	50

CLIENT	ORDER	ROAD NUMBER		VIN (2NVY/4RKY...)		QTY
		FROM	TO	FROM	TO	
Chicago Transit Authority - CTA - Illinois	L849	8100	8149	L82J5F4500874	L82J3F4500923	50
Chicago Transit Authority - CTA - Illinois	L850	8150	8199	L82J5F4500924	L82J6G9775013	50
Chicago Transit Authority - CTA - Illinois	L943	8200	8324	L82JXG9775225	L82J3G9775406	125
Chicago Transit Authority - CTA - Illinois	LB58	8325	8349	L82J7J9776906	L82J8J9776946	25
Clemson Area Transit - South Carolina	L617	—	—	S92U5C4500002	S92U5C4500002	1
Clemson Area Transit - South Carolina	L769	—	—	S92U1D4500418	S92U1D4500418	1
CMBC (TransLink) - British Columbia	L317	9601	9601	L82U973000155	L82U973000155	1
CMBC (TransLink) - British Columbia	L301	9602	9649	L82U373000216	L82U173000263	48
CMBC (TransLink) - British Columbia	L302	9650	9706	L82U673000386	L82U973000351	56
CMBC (TransLink) - British Columbia	L341	V9707	V9725	L82U373000412	L82U573000430	19
CMBC (TransLink) - British Columbia	L380	9726	9747	L82U483000209	L82U683000230	22
CMBC (TransLink) - British Columbia	L381	9748	9781	L82U383000329	L82U483000369	34
CMBC (TransLink) - British Columbia	L382	9782	9791	L82U083000370	L82U783000379	10
CMBC (TransLink) - British Columbia	L412	9401	9401	L82X993000136	L82X993000136	1
CMBC (TransLink) - British Columbia	L454	9402	9470	L82X793000359	L82XX93000453	69
CMBC (TransLink) - British Columbia	L482	9492	9517	L82X894000040	L82X094000064	25
CMBC (TransLink) - British Columbia	L455	9471	9491	L82X093000459	L82X993000489	21
CMBC (TransLink) - British Columbia	L483	9518	9542	L82X294000065	L82X594000089	25
CMBC (TransLink) - British Columbia	L532	9543	9551	L82U093000497	L82U693000505	9
CMBC (TransLink) - British Columbia	L533	9552	9573	L82U193000511	L82U093000537	22
CMBC (TransLink) - British Columbia	L534	9574	9590	L82U694000124	L82U894000139	16
CMBC (TransLink) - British Columbia	LB31	18301	18404	L82L8J3751245	L82L3J3751444	104
CMBC (TransLink) - British Columbia	LB32	18451	18473	L82J5J9776726	L82J4J9776748	23
CMBC (TransLink) - British Columbia	LB74	H19301	H19302	L82M3K3751678	L82M7K3751702	2
CMBC (West Vancouver) - British Columbia	L345	701	702	L82U373000264	L82U573000265	2
CMBC (West Vancouver) - British Columbia	L401	801	803	L82U983000206	L82U283000208	3
CMBC (West Vancouver) - British Columbia	L539	901	909	L82U494000140	L82U994000148	9
CNG Demo (ref. L957)	L840	8093	8093	L82J0E4500716	L82J0E4500716	1
Cold Lake	LA99	5013	5014	L82J7J3751302	L82J9J3751303	2
Cornwall - Ontario	LB55	—	—	L82J8J3751468	L82J8J3751468	1
Cornwall Ontario - Metrolinx	L935	—	—	L82J3F3001838	L82J5F3001839	2
Cornwall Ontario - Metrolinx	LA53	—	—	L82J2H3750892	L82J6H3750894	3
CT Transit - Connecticut	L554	1041	1065	S92U1A4000139	S92U0A4000164	25
CT Transit - Connecticut	L571	1101	1110	S92YXB4000144	S92Y4B4000169	10
CT Transit - Connecticut	L815	1426	1429	S92L0E4500709	S92L0E4500712	4
CT Transit - Connecticut	L814	1462	1473	S92LXE4500717	S92L4E4500728	12
Demo Chicago Transit Authority - CTA	LC53	—	—	L82J4K9777268	L82J4K9777268	1
Duke University - North Carolina	L651	—	—	S92Y1B4000145	S92Y3B4000146	2
Duke University - North Carolina	L938	—	—	L82L8G9775399	L82L0G9775400	2
Duke University - North Carolina	LA38	—	—	L82L9H9775994	L82L9H9775994	1
Duke University - North Carolina	LA39	—	—	S92LXH9775995	S92LXH9775995	1

CLIENT	ORDER	ROAD NUMBER		VIN (2NVY/4RKY...)		QTY
		FROM	TO	FROM	TO	
Durham Region Transit - Ontario	L199	169	169	L82U453000125	L82U453000125	1
Durham Region Transit - Ontario	L212	—	—	L82UX53000128	L82UX53000128	1
Durham Region Transit - Ontario	L213	—	—	L82U153000129	L82U153000129	1
Durham Region Transit - Ontario	L182	182-1	182-1	L82U653000157	L82U653000157	1
Durham Region Transit - Ontario	L224	170	170	L82U963000011	L82U963000011	1
Durham Region Transit Ontario - Metrolinx	L872	8551	8553	L82J0F3001523	L82J4F3001525	3
Durham Region Transit Ontario - Metrolinx	L888	8554	8559	L82J2F3001703	L82J1F3001708	6
Durham Region Transit Ontario - Metrolinx	L996	8560	8563	L82J1G3750414	L82J7G3750417	4
Durham Region Transit Ontario - Metrolinx	LA19	8564	8565	L82J9G3750418	L82J0G3750419	2
Durham Region Transit Ontario - Metrolinx	LA50	8566	8578	L82JXH3750901	L82J1H3750916	13
Durham Region Transit Ontario - Metrolinx	LB11	8579	8589	L82J2H9776354	L82J0H9776367	11
Durham Region Transit Ontario - Metrolinx	LB36	6100	6112	L82J2J3751417	L82J7J3751431	13
Durham Region Transit Ontario - Metrolinx	LB60	7100	7103	L82J5J3751539	L82J5J3751542	4
Durham Region Transit Ontario - metrolinx	LC36	6113	6116	L82J2K3752102	L82J8K3752105	4
Durham Region Transit Ontario - Metrolinx	LC62	9100	9105	S92J7L3752333	S92J6L3752338	6
Fredericton - New Brunswick	L178	8053	8053	L82U653000109	L82U653000109	1
Fredericton - New Brunswick	L225	8061	8061	L82U663000032	L82U663000032	1
Fredericton - New Brunswick	L240	8062	8062	L82U163000181	L82U163000181	1
Fredericton - New Brunswick	L281	8063	8063	L82U363000263	L82U363000263	1
Fredericton - New Brunswick	L276	8064	8065	L82U463000286	L82U663000287	2
Fredericton - New Brunswick	L289	—	—	L82U573000072	L82U573000072	1
Fredericton - New Brunswick	L282	8071	8072	L82UX73000097	L82U173000098	2
Fredericton - New Brunswick	L375	8081	8081	L82U983000142	L82U983000142	1
Fredericton - New Brunswick	L369	1	1	L82U693000018	L82U693000018	1
Fredericton - New Brunswick	L672	8111	8112	L82U0B3000540	L82U2B3000541	2
Fredericton - New Brunswick	L688	8113	8113	L82U8C3000643	L82U8C3000643	1
Fredericton - New Brunswick	L774	8131	8131	L82U7D3000960	L82U7D3000960	1
Fredericton - New Brunswick	L812	—	—	L82J4E3001202	L82J4E3001202	1
Fredericton - New Brunswick	L836	8143	8143	L82J9E3001390	L82J9E3001390	1
Fredericton - New Brunswick	L901	8151	8151	L82J7F3001602	L82J7F3001602	1
Fredericton - New Brunswick	L968	8161	8162	L82J1G3750218	L82J3G3750219	2
Fredericton - New Brunswick	LA15	8171	8174	L82J1H3750589	L82J1H3750592	4
Fredericton - New Brunswick	LA33	8181	8184	L82J6H3750944	L82J1H3750947	4
Gaylord Opryland - Nashville, Tennessee	L223	—	—	L82VX53000221	L82VX53000221	1
Gaylord Opryland - Nashville, Tennessee	L283	—	—	L82V773000034	L82V773000034	1
Gaylord Opryland - Nashville, Tennessee	L353	—	—	L82U583000008	L82U383000010	3
Grand River Transit - GRT - Ontario	L243	2601	2614	L82U463000188	L82U363000201	14
Grand River Transit - GRT - Ontario	L337	2701	2712	L82U373000281	L82UX73000293	12
Grand River Transit - GRT - Ontario	L338	2713	2724	L82U773000431	L82U173000442	12
Grand River Transit - GRT - Ontario	L404	8007	8021	L82U683000244	L82U683000258	15
Grand River Transit - GRT - Ontario	L405	8022	8027	L82W683000259	L82WX83000264	6

CLIENT	ORDER	ROAD NUMBER		VIN (2NVY/4RKY...)		QTY
		FROM	TO	FROM	TO	
Grand River Transit - GRT - Ontario	L464	20901	20913	L82U193000296	L82U493000308	13
Grand River Transit - GRT - Ontario	L560	21001	21009	L82U2A3000246	L82U1A3000254	9
Grand River Transit - GRT - Ontario	L633	21101	21115	L82U7B3000289	L82U8B3000303	15
Grand River Transit - GRT - Ontario	L599	21116	21118	L82X9B3000465	L82X2B3000467	3
Grand River Transit - GRT - Ontario	L631	21119	21121	L82X4B3000468	L82X2B3000470	3
Grand River Transit - GRT - Ontario	L668	21201	21220	L82U6C3000737	L82UXC3000756	20
Grand River Transit Ontario - GRT	LC52	21901	21912	L82J1K9777289	L82J3K9777309	12
Grande Prairie Alberta	L834	—	—	L82J7E3001386	L82J2E3001389	4
Greater Toronto Airports Authority - GTAA - Ontario	L432	432-1	432-1	L82U793000061	L82U793000061	1
Greater Toronto Airports Authority - GTAA - Ontario	L477	L477-1	L477-1	L82U194000001	L82U194000001	1
Greater Toronto Airports Authority - GTAA - Ontario	L616	—	—	L82U4C4500001	L82U4C4500001	1
Guelph - Ontario	L211	184	184	L82U853000127	L82U853000127	1
Guelph - Ontario	L187	186	186	L82U553000215	L82U553000215	1
Guelph - Ontario	L187	188	188	L82U953000217	L82U953000217	1
Guelph - Ontario	L241	190	191	L82U563000183	L82U763000184	2
Guelph - Ontario	L241	193	194	L82U063000186	L82U263000187	2
Guelph - Ontario	L397	195	198	L82U183000152	L82U783000155	4
Guelph - Ontario	L418	199	205	L82U883000410	L82U983000416	7
Guelph - Ontario	L431	206	220	L82U793000030	L82U793000044	15
Guelph - Ontario	L579	221	224	L82UXA3000401	L82U5A3000404	4
Guelph - Ontario	L669	225	228	L82U9B3000536	L82U4B3000539	4
Guelph - Ontario	L715	234	235	L82U3C3000792	L82U5C3000793	2
Guelph - Ontario	L767	237	239	L82UXD3000967	L82U3D3000969	3
Guelph - Ontario	L835	240	243	L82J0E3001391	L82J6E3001394	4
Guelph - Ontario	L927	244	247	L82J1F3001756	L82J9F3001763	4
Guelph - Ontario	L985	248	251	L82J7G3750255	L82J2G3750258	4
Guelph - Ontario	LA54	252	275	L82J1H3750849	L82J0H3750891	24
Guelph - Ontario	LC88	276	280	L82J8L3752378	L82JXL3752382	5
Halifax - Nova Scotia	L558	717	731	S92UXA3000293	S92U6A3000307	15
Halifax - Nova Scotia	L613	732	741	S92UXB3000019	S92UXB3000028	10
Halifax - Nova Scotia	L693	526	534	L82U8C3000657	L82U7C3000665	9
Halifax - Nova Scotia	L710	1160	1161	L82U7C3000780	L82U9C3000781	2
Halifax - Nova Scotia	L708	742	761	S92UXC3000782	S92U3C3000803	20
Halifax - Nova Scotia	LA11	1208	1236	L82J1G9775579	L82J4G9775608	29
Halifax - Nova Scotia	LA14	1237	1237	L82J1G9775596	L82J1G9775596	1
Halifax - Nova Scotia	LA27	1238	1276	L82J5H9775778	L82J9H9775816	39
Halifax - Nova Scotia	LB61	1277	1284	L82J9J9776664	L82J6J9776671	8
Halifax - Nova Scotia	LB70	1285	1299	L82J4J9776829	L82J9J9776843	15
Halifax - Nova Scotia	LC11	1300	1334	L82JXK9777310	L82J5K9777344	35

CLIENT	ORDER	ROAD NUMBER		VIN (2NVY/4RKY...)		QTY
		FROM	TO	FROM	TO	
Hamilton - Ontario - Metrolinx	L885	1501	1524	L82K3F4501093	L82K0F4501214	24
Hamilton - Ontario - Metrolinx	L956	1601	1632	L82K2G9775325	L82K3G9775415	32
Hamilton - Ontario - Metrolinx	LA05	1633	1643	L82K4G9775553	L82K7G9775577	11
Hamilton - Ontario - Metrolinx	LA63	1701	1719	L82K5J9776430	L82K5J9776461	30
Honolulu - Hawaii	L559	201	224	L82U6A4000113	L82U7A4000136	24
Houston - Texas	L737	1510	1510	S92U4D4500297	S92U4D4500297	1
Houston - Texas	L755	1511	1579	S92U4D4500333	S92U8D4500402	69
Houston - Texas	L951	1915	1915	L82J0G9775203	L82J0G9775203	1
Houston - Texas	L952	1580	1580	S92J5G9775318	S92J5G9775318	1
Houston - Texas	L981	1916	1994	L82J8G9775434	L82J4G9775513	79
Houston - Texas	L982	1581	1582	S92J5G9775514	S92J7G9775515	2
Houston - Texas	L982	1583	1583	S92J9G9775516	S92J9G9775516	1
Houston - Texas	L982	1584	1586	S92J2G9775518	S92J4G9775522	3
Houston - Texas	L982	1587	1587	S92J8G9775524	S92J8G9775524	1
Houston - Texas	L982	1588	1599	S92J1G9775526	S92J5G9775545	12
Houston - Texas	LB63	2050	2050	L82K2J9776708	L82K2J9776708	1
Houston - Texas	LB72	2051	2069	L82K6J9776887	L82K4J9776905	19
Houston Texas - Metro	LC55	2070	2079	L82KXK9777378	L82K0K9777387	10
Houston Texas - Metro	LC91	2500	2501	L82J4L9777479	L82J0L9777480	2
Houston Texas - Metro	LC92	2502	2534	L82J8L9777601	L82J3L9777618	33
Kings Transit - Nova Scotia	L581	—	—	L82U2B3000054	L82U2B3000054	1
Kingston - Ontario	LB34	1821	1841	L82J3J3751412	L82J0J3751416	5
Kingston - Ontario	L880	1502	1502	L82JXF3001786	L82JXF3001786	1
Kingston - Ontario	L925	1504	1510	L82J5F3001808	L82J5F3001811	4
Kingston - Ontario	L889	1687	1689	L82J1G3750252	L82J5G3750254	3
Kingston - Ontario	L954	1683	1686	L82J4G3750259	L82J4G3750262	4
Kingston - Ontario	LA60	1825	1837	L82J7H3750922	L82J8H3750931	6
Kingston - Ontario	LA59	1803	1818	L82JXH3750932	L82J4H3750943	11
Kingston - Ontario	LB68	1901	1901	L82J1K3751913	L82J1K3751913	1
Kingston - Ontario	LB69	1920	1951	L82J3K3751914	L82J0K3751918	5
Krapf's Coaches - Pennsylvania (ref. L833)	L754	—	—	L82U4D4500405	L82U4D4500405	1
Leduc Bus Line - Ontario	L181	—	—	L82V853000119	L82V853000119	1
Leduc Bus Line - Ontario	L228	228-1	228-1	L82V663000041	L82V663000041	1
Leduc Bus Line - Ontario	L346	—	—	L82UX83000053	L82UX83000053	1
Lethbridge - Alberta	L489	165	169	L82U493000454	L82U193000458	5
Lethbridge - Alberta	L868	—	—	L82J2F3001510	L82J2F3001510	1
Lethbridge - Alberta	L997	181	186	L82J5G9775570	L82JXG9775578	6
Lethbridge - Alberta	LA91	189	192	L82J3J9776580	L82J9J9776583	4
Lethbridge - Alberta	LB95	193	198	L82J1K3751894	L82J0K3751899	6
LYNX - Florida	L725	—	—	S92Y9D4500329	S92Y5D4500330	2
LYNX - Florida	L764	—	—	S92Y7D4500331	S92Y9D4500332	2

CLIENT	ORDER	ROAD NUMBER		VIN (2NVY/4RKY...)		QTY
		FROM	TO	FROM	TO	
LYNX - Florida	L785	—	—	S92L6E4500505	S92L8E4500506	2
Marketing Sales Demo - MSD 6 Houston	L628	—	—	L82U8C4500003	L82UXC4500004	2
Maryland Transit Authority - MTA	LB82	20001	20001	L82J8K9777273	L82J8K9777273	1
Maryland Transit Authority - MTA	LB83	20031	20031	S92J9K9777288	S92J9K9777288	1
Maryland Transit Authority - MTA	LC27	20002	20030	L82JXL9777602	L82J4L9777658	29
Maryland Transit Authority - MTA	LC28	20032	20070	S92J5L9777628	S92J3L9777689	39
Milton - Ontario	LB33	1804	1804	L82J7J3751543	L82J7J3751543	1
Milton - Ontario	L884	1701	1702	L82J0G3750338	L82J2G3750339	2
Milton - Ontario	LA51	1801	1803	L82J3H3750917	L82J7H3750919	3
Milton - Ontario	LC71	1901	1902	L82J1K3752270	L82J3K3752271	2
Minnesota Valley Transit Authority - MVTA	L706	4252	4258	L82U4C4500127	L82UXC4500133	7
Mississauga Ontario	LA64	1730	1766	L82J2H9776077	L82J7H9776253	37
Mississauga Ontario	LA65	1770	1799	S92J8H9776254	S92J2H9776315	30
Mississauga Ontario	LB12	1801	1812	L82J9J9776714	L82J3J9776725	12
Mississauga Ontario	LC26	1901	1910	L82L9K3751966	L82LXK3751975	10
Moncton (Codiac) - New Brunswick	L226	506	507	L82U863000033	L82UX63000034	2
Moncton (Codiac) - New Brunswick	L334	600	603	L82U673000212	L82U173000215	4
Moncton (Codiac) - New Brunswick	L358	358-1	358-1	L82U093000001	L82U093000001	1
Moncton (Codiac) - New Brunswick	L361	361-1	361-1	L82U293000002	L82U293000002	1
Moncton (Codiac) - New Brunswick	L569	—	—	L82U4B4000001	L82U4B4000001	1
Moncton (Codiac) - New Brunswick	L570	—	—	L82U6B4000002	L82U6B4000002	1
Moncton (Codiac) - New Brunswick	LA06	—	—	L82J3G9775552	L82JXG9775564	9
Moncton (Codiac) - New Brunswick	LA42	—	—	L82J8H9776066	L82J0H9776076	11
Moncton (Codiac) - New Brunswick	LA58	—	—	L82J2J9776389	L82J2J9776389	1
Moncton (Codiac) - New Brunswick	LB84	N/A	N/A	L82J3K9777004	L82J3K9777004	1
Montgomery County - Maryland	LC34	1946001D	1946015D	S92J4L9777474	S92J2L9777490	15
Montgomery County - North Carolina	LC33	194600	194600	S92J1K9777351	S92J1K9777351	1
Moose Jaw - Saskatchewan	L344	17	25	L82U083000143	L82U883000147	5
MTD - Santa Barbara, California	L730	—	—	S92J8E4500567	S92J1E4500569	3
New York City Transit - New York	L536	1200	1201	S92U793000490	S92U993000491	2
New York City Transit - New York	L545	1202	1289	S92U5A4000001	S92U0A4000098	88
New York City Transit - New York	L608	8000	8014	L82U6B4000047	L82U0B4000061	15
New York City Transit - New York	L620	8015	8074	L82U2B4000062	L82U7B4000123	60
New York City Transit - New York	L621	8075	8089	L82U9B4000124	L82U9B4000138	15
New York City Transit - New York	L643	5895	5895	S92U1B4000143	S92U1B4000143	1
New York City Transit - New York	L670	5770	5894	S92U9B4000147	S92UXC4500061	125
New York City Transit - New York	L681	5896	5283	S92U2C4500023	S92U9C4500195	122
New York City Transit - New York	L692	5284	5363	S92U3C4500158	S92U3D4500274	80
New York City Transit - New York	L841	8094	8134	L82J2F4500959	L82JXF4501034	41
New York City Transit - New York	L841	8184	8206	L82J1F4501035	L82J0F4501057	23
New York City Transit - New York	L841	8252	8269	L82J2F4501058	L82J2F4501075	18

CLIENT	ORDER	ROAD NUMBER		VIN (2NVY/4RKY...)		QTY
		FROM	TO	FROM	TO	
New York City Transit - New York	L842	8090	8093	L82J4F4501076	L82JXF4501079	4
New York City Transit - New York	L842	8207	8213	L82J6F4501161	L82J7F4501170	7
New York City Transit - New York	L842	8399	8408	L82J6F4501080	L82J2F4501089	10
New York City Transit - New York	L842	8318	8332	L82J9F4501090	L82J7F4501105	15
New York City Transit - New York	L842	8359	8373	L82J9F4501106	L82J3F4501120	15
New York City Transit - New York	L842	8409	8432	L82J5F4501121	L82JXF4501146	24
New York City Transit - New York	L842	8481	8491	L82J1F4501147	L82J8F4501159	11
New York City Transit - New York	L843	8135	8153	L82J5F4501197	L82J9F4501221	19
New York City Transit - New York	L843	8214	8230	L82J9F4501171	L82J1F4501195	17
New York City Transit - New York	L843	8270	8293	L82J0F4501222	L82J7F4501251	24
New York City Transit - New York	L843	8333	8347	L82J9F4501252	L82J1G9775016	15
New York City Transit - New York	L843	8374	8380	L82J3G9775017	L82J9G9775023	7
New York City Transit - New York	L844	8381	8170	L82J0G9775024	L82J0G9775105	82
New York City Transit - New York	L845	8171	8480	L82J2G9775106	L82J6G9775187	82
New York City Transit - New York	L958	5439	5442	S92J9G9775533	S92J9G9775631	4
New York City Transit - New York	L959	5443	5443	S92J0H9776118	S92J0H9776118	1
New York City Transit - New York	LB59	5444	5484	S92J7H9776195	S92J6H9776379	41
New York City Transit - New York	LA23	5485	5530	S92J5J9776380	S92J6J9776517	46
New York City Transit - New York	LA73	8504	8507	L82J8J9776445	L82J8J9776476	4
New York City Transit - New York	LB29	5531	5566	S92J9J9776687	S92J6J9776873	36
New York City Transit - New York	LA76	8508	8633	L82J9J9776924	L82J8K9777144	125
New York City Transit - New York	LB99	5567	5602	S92J2J9776935	S92J5K9777000	36
New York City Transit - New York	LB78	8526	8526	L82J3K9776984	L82J3K9776984	1
New York City Transit - New York	LC32	8634	8754	L82JXK9777145	L82J5K9777277	121
NFTA - Buffalo, New York	L877	1501	1501	L82K0F4500984	L82K0F4500984	1
NFTA - Buffalo, New York	L897	1502	1520	L82K1F4501223	L82K1G9775008	19
NFTA - Buffalo, New York	L947	1601	1624	L82KXG9775248	L82K3G9775320	24
NFTA - Buffalo, New York	LA24	1701	1716	L82K3H9775822	L82K5H9775837	16
NFTA - Buffalo, New York	LA30	1717	1724	L82J8H9775838	L82J5H9775845	8
NFTA - Buffalo, New York	LB21	1817	1824	L82J9J9776518	L82J8J9776526	8
Niagara Falls - Ontario	L499	2986	2989	L82U093000564	L82U693000567	4
Niagara Falls - Ontario	L652	—	—	S92U3C3000607	S92U6C3000617	11
Niagara Falls - Ontario	L653	—	—	L82U9C3000618	L82U9C3000621	5
Niagara Falls - Ontario	L771	1396	1397	L82U9D3000958	L82U0D3000959	2
Niagara Falls - Ontario	L987	1601	1604	L82J6G3750344	L82J1G3750347	4
Niagara Falls Ontario - 60' metrolinx	LB98	1935	1936	S92J9K3752106	S92J0K3752107	2
Niagara Falls Ontario - 60' metrolinx	LC61	1937	1938	S92J2K3752108	S92J4K3752109	2
Niagara Falls Ontario - Metrolinx	LA97	1805	1808	L82J0J3750993	L82J6J3750996	4
Niagara Falls Ontario - Metrolinx	LB13	1811	1811	L82J8J3750997	L82J8J3750997	1
Niagara Falls Ontario - Metrolinx	LA98	1809	1810	S92J7J3751003	S92J9J3751004	2
Niagara Falls Ontario - Metrolinx	LC89	1930	1934	L82J2L9777528	L82J4L9777532	5

CLIENT	ORDER	ROAD NUMBER		VIN (2NVY/4RKY...)		QTY
		FROM	TO	FROM	TO	
Niagara Parks Commission - Ontario	L685	—	—	S92U9C3000644	S92U8C3000652	9
Niagara Parks Commission - Ontario	L656	—	—	L82U0C3000653	L82U2C3000654	2
North Bay - Ontario	L895	784	785	L82J7F3001678	L82J9F3001679	2
North Bay - Ontario	L979	786	787	L82J4G3750312	L82J6G3750313	2
North Bay - Ontario	LB48	788	790	L82J7J3751395	L82J0J3751397	3
North Bay Ontario - metrolinx	LC38	792	793	L82J3K3752092	L82J7K3752094	2
Oakville - Ontario	LB93	—	—	L82J3K3751749	L82J5K3751753	5
Oakville - Ontario	LC57	—	—	L82J6K3752121	L82J5K3752126	6
Oakville - Ontario	L874	—	—	L82J6F3001526	L82JXF3001531	6
Oakville - Ontario	L881	—	—	L82J2F3001717	L82J8F3001740	5
Oakville - Ontario	L945	—	—	L82J9G3750211	L82JXG3750217	7
Oakville - Ontario	LA55	—	—	L82J6H3750880	L82J5H3750885	6
Orillia Ontario - Metrolinx	L965	1722	1724	L82J3G3750320	L82J7G3750322	3
Orillia Ontario - Metrolinx	LA61	1825	1826	L82J2J3751031	L82J4J3751032	2
Ottawa - OC transpo	LB80	4601	4609	L82J0J3751576	L82J3J3751586	9
Ottawa - OC transpo	LC16	4610	4682	L82J7K3751771	L82JXK3751912	73
Ottawa - OC transpo	LC67	4683	4736	L82J7K3752127	L82J4K3752182	54
Ottawa - OC transpo	LC68	4737	4755	L82J0K9777428	L82J3K9777472	39
Peterborough - Ontario	L202	—	—	L82U253000110	L82U653000112	3
Peterborough - Ontario	L411	36	50	L82U283000354	L82U083000532	15
Peterborough - Ontario	L490	—	—	L82UX93000345	L82U593000348	4
Peterborough - Ontario	L770	55	60	L82U0D3000993	L82UXD3000998	6
Peterborough - Ontario	L870	61	63	L82JXF3001612	L82J3F3001614	3
Peterborough - Ontario	L919	64	66	L82J6F3001767	L82JXF3001769	3
Peterborough - Ontario	L966	67	71	L82J2G3750230	L82JXG3750234	5
Peterborough - Ontario	LA41	7217	7617	L82J1H3750706	L82J3H3750710	5
Peterborough - Ontario	LB20	7819	8019	L82J2K3751919	L82J0K3751921	3
Red Deer - Alberta	L726	—	—	L82UXC3000840	L82U1C3000841	2
Red Deer - Alberta	L766	1104	1105	L82U7D3001025	L82U9D3001026	2
Red Deer - Alberta	L772	1106	1108	L82J2E3001120	L82J6E3001122	3
Red Deer - Alberta	L813	10008	10009	L82J2E3001361	L82J4E3001362	2
Red Deer - Alberta	L869	—	—	L82J9F3001570	L82J0F3001571	2
Red Deer - Alberta	L926	—	—	L82J2F3001796	L82J4F3001797	2
Red Deer - Alberta	L960	10021	10025	L82K9G9775418	L82K3G9775429	5
Red Deer - Alberta	L924	10104	10147	L82K0G9775517	L82KXG9775542	12
Red Deer - Alberta	LB25	10074	10084	L82K5J9776525	L82K8J9776535	10
Regina - Saskatchewan	L239	609	610	L82U363000179	L82UX63000180	2
Regina - Saskatchewan	L304	611	616	L82U373000457	L82U773000462	6
Regina - Saskatchewan	L356	356-1	356-1	L82U883000150	L82U883000150	1
Regina - Saskatchewan	L360	—	—	L82U283000290	L82U283000290	1
Regina - Saskatchewan	L459	617	624	L82UX83000537	L82U783000544	8

CLIENT	ORDER	ROAD NUMBER		VIN (2NVY/4RKY...)		QTY
		FROM	TO	FROM	TO	
Regina - Saskatchewan	L476	625	628	L82U893000313	L82U393000316	4
Regina - Saskatchewan	L561	631	644	L82U8B4000003	L82UXB4000018	14
Regina - Saskatchewan	L639	645	654	L82U1B3000336	L82U2B3000345	10
Regina - Saskatchewan	L748	655	662	L82U3D3000874	L82U0D3000881	8
Regina - Saskatchewan	L776	663	669	L82U4D3001001	L82U5D3001007	7
Regina - Saskatchewan	L807	671	685	L82J8E3001137	L82J2E3001151	15
Regina - Saskatchewan	L892	686	691	L82J5F3001484	L82J4F3001489	6
Regina - Saskatchewan	L949	692	696	L82J3G3750205	L82J0G3750209	5
Regina - Saskatchewan	L992	—	—	L82J6G3750294	L82J3G3750298	5
Regina - Saskatchewan	LA44	814	829	L82J0H3750776	L82J7H3750791	16
Regina - Saskatchewan	LB16	830	830	L82J0H3750793	L82J0H3750793	1
Regina - Saskatchewan	LB17	831	831	L82J2H3750794	L82J2H3750794	1
Regina - Saskatchewan	LB18	832	832	L82J4H3750795	L82J4H3750795	1
Regina - Saskatchewan	LA66	833	836	L82J0J3751612	L82J6J3751615	4
Rochester New York - RTS	LB76	1901	1901	L82J3K9777052	L82J3K9777052	1
Rochester New York - RTS	LB77	1902	1910	L82J4K9777352	L82J3K9777360	9
San Antonio Texas	LA10	422	446	L82K9G9775628	L82K8G9775653	25
San Antonio Texas	LA22	447	555	L82K8H9775654	L82K0H9775762	109
San Antonio Texas	LA34	556	580	L82K0H9775857	L82K8H9775881	25
San Antonio Texas	LA35	581	691	L82KXH9775882	L82K8H9775993	111
San Antonio Texas	LB26	692	735	L82KXJ9776536	L82K6J9776579	44
San Antonio Texas	LB43	970	987	L82K4J9776791	L82K1J9776828	18
San Antonio Texas	LD11	726	738	L82K1L9777562	L82K8L9777574	13
San Antonio Texas	LD12	988	989	L82KXL9777575	L82K1L9777576	2
San Antonio Texas	LC70	801	806	L82K3L9777577	L82K3L9777577	6
San Antonio Texas	LD13	739	747	L82K4L9777619	L82K4L9777619	9
San Joaquin County - California	L768	—	—	S92L4D4500422	S92L3D4500427	6
San Juan Puerto Rico	LC03	2019-01	2019-06	L82J9K9777251	L82J8K9777256	6
San Juan Puerto Rico	LD01	2020-01	2020-01	L82J0L9777561	L82J0L9777561	1
Sarnia Ontario	L873	151	152	L82J0F3001599	L82J0F3001600	2
Sarnia Ontario	L883	153	153	L82J4G3750021	L82J4G3750021	1
Sarnia Ontario	L963	162	162	L82J7G3750305	L82J7G3750305	1
Sarnia Ontario	LA36	171	172	L82J8H3750752	L82JXH3750753	2
Saskatoon - Saskatchewan	L359	—	—	S92U583000289	S92U583000289	1
Saskatoon - Saskatchewan	L551	1005	1007	S92UXA3000178	S92U8A3000180	3
Saskatoon - Saskatchewan	L568	—	—	S92U9B3000013	S92U9B3000013	1
Saskatoon - Saskatchewan	L618	—	—	S92U1C3000377	S92U1C3000377	1
Saskatoon - Saskatchewan	L690	1201	1204	L82U6C3000690	L82U1C3000693	4
Saskatoon - Saskatchewan	L831	1401	1405	L82J7E3001307	L82J9E3001311	5
Saskatoon - Saskatchewan	L894	1501	1510	L82J0F3001490	L82J7F3001499	10
Saskatoon - Saskatchewan	L953	1601	1610	L82J9G3750158	L82JXG3750167	10

CLIENT	ORDER	ROAD NUMBER		VIN (2NVY/4RKY...)		QTY
		FROM	TO	FROM	TO	
Saskatoon - Saskatchewan	LA29	1701	1711	L82J7H9775846	L82JXH9775856	11
Saskatoon - Saskatchewan	LA92	1718	1732	L82J0H9776319	L82J8H9776343	15
Saskatoon - Saskatchewan	LB73	1901	1907	L82J6K9776977	L82J1K9776983	7
Sault Ste. Marie Ontario	L934	—	—	L82JXG3750038	L82JXG3750038	1
Sault Ste. Marie Ontario	LC06	—	—	L82J3K3751900	L82J5K3751901	2
Sault Ste-Marie Transit Services - Ontario (ref. L751)	L754	—	—	L82U7D4500284	L82U7D4500284	1
SEPTA - Pennsylvania	L728	—	—	L82W7D4500335	L82W7D4500335	1
SEPTA - Pennsylvania	L749	7302	7354	S92Y7D4500409	S92L2E4500470	53
SEPTA - Pennsylvania	L743	7356	7370	S92L1E4500489	S92L2E4500503	15
SEPTA - Pennsylvania	L741	7355	7355	S92L4E4500504	S92L4E4500504	1
SEPTA - Pennsylvania	L744	8601	8689	L82L7E4500570	L82LXE4500661	89
SEPTA - Pennsylvania	L742	7371	7414	S92L6E4500729	S92L7E4500772	44
SEPTA - Pennsylvania	L745	7415	7415	S92L0F4500873	S92L0F4500873	1
SEPTA - Pennsylvania	L746	7416	7454	S92L7F4500952	S92L8F4501012	39
SEPTA - Pennsylvania	L861	7300	7484	S92L5G9775188	S92L8G9775220	32
SolTrans Solano County Transit California - CNG	L990	—	—	L82K5G9775464	L82K5G9775464	1
St. Catharines Ontario - Metrolinx	L879	1501	1504	L82J4F3001587	L82J4F3001590	4
St. Catharines Ontario - Metrolinx	L898	1560	1560	S92J4F3001663	S92J4F3001663	1
St. Catharines Ontario - Metrolinx	L882	1601	1605	L82J9G3750225	L82J9G3750229	5
St. Catharines Ontario - Metrolinx	LB06	1860	1862	S92J1J3751000	S92J5J3751002	3
St. Catharines Ontario - Metrolinx	LB09	1740	1740	L82J6J3751033	L82J6J3751033	1
St. Catharines Ontario - Metrolinx	LA62	1801	1813	L82J8J3751034	L82J4J3751046	13
St. Catharines Ontario - Metrolinx	LC84	2040	2043	L82J6L9777533	L82J1L9777536	4
St. John - New Brunswick	L272	—	—	S92U483000011	S92U483000011	1
St. John - New Brunswick	L273	—	—	S92U383000050	S92U383000050	1
St. John - New Brunswick	L871	40585	40586	L82J8F3001592	L82JXF3001593	2
St. John - New Brunswick	L939	40687	40687	L82J0G3750078	L82J0G3750078	1
St. John - New Brunswick	LB05	38888	38899	L82J8J3750983	L82J1J3750999	12
St. John's - Newfoundland	L242	0753	0756	L82U273000028	L82U273000031	4
St. John's - Newfoundland	L352	0857	0861	L82U683000003	L82U383000007	5
St. John's - Newfoundland	L403	0962	0965	L82U299300014	L82U493000017	4
St. John's - Newfoundland	L503	1066	1066	L82U4A3000071	L82U4A3000071	1
St. John's - Newfoundland	L687	1201	1209	L82U7C3000598	L82U2C3000606	9
St. John's - Newfoundland	L731	1310	1314	L82U3C3000842	L82U2C3000847	5
St. John's - Newfoundland	L808	1415	1419	L82J4E3001152	L82J1E3001156	5
St. John's - Newfoundland	L875	1520	1525	L82JXF3001478	L82J3F3001483	6
St. John's - Newfoundland	L930	1626	1630	L82J7F3001826	L82J9F3001830	5
Stratford - Ontario	L371	—	—	L82U183000104	L82U183000104	1
Stratford - Ontario	L493	—	—	L82U2A3000019	L82U2A3000019	1
Stratford - Ontario	L634	—	—	L82UXB3000352	L82UXB3000352	1

CLIENT	ORDER	ROAD NUMBER		VIN (2NVY/4RKY...)		QTY
		FROM	TO	FROM	TO	
Stratford - Ontario	L752	—	—	L82U9D3000863	L82U9D3000863	1
Stratford - Ontario	L893	—	—	L82J9F3001584	L82J0F3001585	2
Stratford - Ontario	LB19	—	—	L82J3J3751183	L82J5J3751184	2
Strathcona County Transit - Alberta	L233	924	929	L82V963000101	L82V863000106	6
Strathcona County Transit - Alberta	L303	930	936	L82U073000156	L82U673000162	7
Strathcona County Transit - Alberta	L383	—	—	L82U083000269	L82U083000269	1
Strathcona County Transit - Alberta	L406	937	939	L82U783000270	L82U083000272	3
Strathcona County Transit - Alberta	L407	940	943	L82W083000273	L82W683000276	4
Strathcona County Transit - Alberta	L457	944	949	L82U683000597	L82U683000602	6
Strathcona County Transit - Alberta	L523	2010	2010	L82U693000603	L82U693000603	1
Strathcona County Transit - Alberta	L524	3005	3010	L82X593000604	L82X493000609	6
Strathcona County Transit - Alberta	L580	2011	2023	L82U1A3000464	L82U8A3000476	13
Strathcona County Transit - Alberta	L659	2024	2028	L82U7B3000440	L82U4B3000444	5
Sudbury - Ontario	L208	—	—	L82U653000191	L82UX53000193	3
Sudbury - Ontario	L250	—	—	L82U063000236	L82U263000240	5
Sudbury - Ontario	L251	—	—	L82U063000241	L82U263000242	2
Sudbury - Ontario	L293	—	—	L82U673000128	L82U673000131	4
Sudbury - Ontario	L294	—	—	L82U873000132	L82UX73000133	2
Sudbury - Ontario	L385	781	782	L82U583000137	L82U783000138	2
Sudbury - Ontario	L399	783	784	L82U983000139	L82U583000140	2
Sudbury - Ontario	L386	785	785	L82U783000141	L82U783000141	1
Sudbury - Ontario	L465	791	795	L82U593000317	L82U793000321	5
Sudbury - Ontario	L552	801	808	L82U3A3000238	L82U0A3000245	8
Sudbury - Ontario	L632	811	817	L82U9B3000326	L82U4B3000332	7
Sudbury - Ontario	L740	831	833	L82U1D3000887	L82U5D3000889	3
Sudbury - Ontario	L890	851	855	L82JXF3001609	L82J6F3001641	5
Sudbury - Ontario	L994	861	865	L82J1G3750364	L82J9G3750368	5
Sudbury - Ontario	LA46	871	873	L82J1H3750821	L82J5H3750823	3
Sudbury - Ontario	LB27	881	883	L82J9J3751382	L82J2J3751384	3
Thunder Bay - Ontario	L221	142	144	L82U863000033	L82UX63000034	3
Thunder Bay - Ontario	L285	—	—	L82U473000046	L82U873000048	3
Thunder Bay - Ontario	L408	—	—	L82U283000239	L82U483000243	5
Thunder Bay - Ontario	L453	—	—	L82U283000533	L82U683000535	3
Thunder Bay - Ontario	L488	—	—	L82U193000332	L82U593000334	3
Thunder Bay - Ontario	L614	—	—	L82UXB3000061	L82U3B3000063	3
Thunder Bay - Ontario	L662	20168	20168	L82U3B3000533	L82U7B3000535	3
Thunder Bay - Ontario	L739	—	—	L82U3D3000860	L82U7D3000862	3
Thunder Bay - Ontario	L806	—	—	L82J6E3001170	L82J8E3001171	2
Thunder Bay - Ontario	L863	—	—	L82J8F3001558	L82J6F3001560	3
Thunder Bay Ontario - Metrolinx	L944	—	—	L82J6G3750084	L82JXG3750086	3
Thunder Bay Ontario - Metrolinx	LA01	—	—	L82J5H3750448	L82J7H3750449	2

CLIENT	ORDER	ROAD NUMBER		VIN (2NVY/4RKY...)		QTY
		FROM	TO	FROM	TO	
Thunder Bay Ontario - Metrolinx	LA57	—	—	L82J8H3750895	L82J8H3750928	12
Timmins - Ontario	L184	184-1	184-1	L82UX53000081	L82UX53000081	1
Timmins - Ontario	L254	254-1	254-1	L82UX73000035	L82UX73000035	1
Timmins - Ontario	L426	—	—	L82U783000480	L82U883000536	2
Timmins - Ontario	L475	—	—	L82U493000311	L82U693000312	2
Timmins - Ontario	L550	—	—	L82U8A3000171	L82UXA3000172	2
Timmins - Ontario	L661	—	—	L82U9B3000486	L82U9B3000486	1
Timmins - Ontario	L720	12-98	12-98	L82U0C3000829	L82U0C3000829	1
Timmins - Ontario	L783	—	—	L82U8D3001017	L82UXD3001018	2
Timmins - Ontario	L839	—	—	L82J8E3001395	L82J8E3001395	1
Timmins - Ontario	L995	—	—	L82JXG3750377	L82JXG3750377	1
Timmins - Ontario	LB07	—	—	L82J1J3751005	L82J3J3751006	2
Timmins - Ontario	LC02	—	—	L82JXK3751926	L82JXK3751926	1
Toronto Transit Commission - TTC - Ontario	L729	9000	9000	S92U9D3000905	S92U9D3000905	1
Toronto Transit Commission - TTC - Ontario	L738	9001	9026	S92J6D3001094	S92J7D3001119	26
Toronto Transit Commission - TTC - Ontario	L777	9027	9152	S92J7E3001123	S92J6E3001372	126
Toronto Transit Commission - TTC - Ontario	L859	8400	8400	L82J5F3001405	L82J5F3001405	1
Toronto Transit Commission - TTC - Ontario	L860	8401	8504	L82J0F3001554	L82JXF3001805	104
Toronto Transit Commission - TTC - Ontario	L937	8510	8617	L82J9G3750001	L82J3G3750401	108
Toronto Transit Commission - TTC - Ontario	L998	8620	8716	L82J3H3750545	L82J4H3750683	97
Toronto Transit Commission - TTC - Ontario	LA67	8720	8919	L82J4H9775996	L82J3H9776248	200
Toronto Transit Commission - TTC - Ontario	LA68	8920	8964	L82J6H3750796	L82JXH3750848	45
Toronto Transit Commission - TTC - Ontario	LA69	9200	9239	L82J9J9776390	L82JXJ9776429	40
Toronto Transit Commission - TTC - Ontario	LB45	3100	3179	L82J8J3751163	L82J8J3751244	80
Toronto Transit Commission - TTC - Ontario	LB28	3180	3329	L82J0J9776584	L82J4J9776815	150
Toronto Transit Commission - TTC - Ontario	LB62	3400	3400	L82L5J3751381	L82L5J3751381	1
Toronto Transit Commission - TTC - Ontario	LB75	3330	3369	L82J6J9776816	L82J5J9776886	40
Toronto Transit Commission - TTC - Ontario	LB79	3401	3454	L82L5J3751445	L82L2J3751502	54
Toronto Transit Commission - TTC - Ontario	LB57	3455	3569	L82L4J3751503	L82L9K3751739	115
Toronto Transit Commission - TTC - Ontario	LB89	3570	3654	L82L6K3752007	L82LXK3752091	85
University of Alabama - Alabama	L295	7001	7001	L82U173000134	L82U173000134	1
University of Alabama - Alabama	L296	7002	7003	L82U373000135	L82U573000136	2
University of Alabama - Alabama	L310	7004	7013	L82U973000267	L82UX73000276	10
University of Alabama - Alabama	L311	7014	7017	L82U173000277	L82U173000280	4
University of Alabama - Alabama	L479	479-1	479-1	L82U394000002	L82U394000002	1
University of Alabama - Alabama	L480	480-1	480-1	L82U594000003	L82U594000003	1
University of Alabama - Alabama	L573	—	—	L82U9A4000137	L82U0A4000138	2
University of Alabama - Alabama	L640	—	—	L82U9B4000141	L82UOB4000142	2
University of Alabama - Alabama	L671	7024	7025	L82U5C4500119	L82U1C4500120	2
University of Alabama - Alabama	L727	7026	7027	L82U4D4500310	L82U6D4500311	2
University of Alabama - Alabama	L787	7028	7029	L82J2E4500507	L82J4E4500508	2

CLIENT	ORDER	ROAD NUMBER		VIN (2NVY/4RKY...)		QTY
		FROM	TO	FROM	TO	
University of Alabama - Alabama	L902	7030	7030	L82J2F4500993	L82J4F4500994	2
University of Alabama - Alabama	L961	7032	7033	L82J7G9775294	L82J9G9775295	2
University of Alabama - Alabama	LA02	7034	7037	L82J8G9775546	L82JXG9775550	4
University of Colorado - Colorado	L237	—	—	L82U163000164	L82U363000165	2
University of Colorado - Colorado	L336	—	—	L82U773000266	L82U773000266	1
University of Colorado - Colorado	L427	—	—	S92U693000027	S92U693000027	1
University of Colorado - Colorado	L428	—	—	S92U893000028	S92U893000028	1
University of Colorado - Colorado	L627	—	—	S92UXB4000139	S92U6B4000140	2
Vancouver Airport Authority - YVR British Columbia	L912	173	178	L82L5F3001812	L82L4F3001817	6
Vancouver Airport Authority - YVR British Columbia	L856	705	706	L82LXH3750530	L82L1H3750531	2
Walt Disney World - Florida	L535	1204	1213	L82UXA4000003	L82U0A4000012	10
Walt Disney World - Florida	L763	—	—	S92U0D3001019	S92U4D3001024	6
Welland Ontario - Metrolinx	L866	—	—	L82J9F3001648	L82J9F3001648	1
Welland Ontario - Metrolinx	L933	—	—	L82J1G3750011	L82J1G3750011	1
Welland Ontario - Metrolinx	L991	—	—	L82J9G3750287	L82J9G3750287	1
Welland Ontario - Metrolinx	LA52	—	—	L82J2H3750911	L82J4H3750912	2
Welland Ontario - Metrolinx	LA93	—	—	L82J6H3750913	L82J6H3750913	1
Welland Ontario - Metrolinx	LC19	—	—	L82J2K3751922	L82J4K3751923	2
Welland Ontario - Metrolinx	LC37	—	—	L82J6K3751924	L82J8K3751925	2
Welland Ontario - Metrolinx	LC85	—	—	L82J0L9777527	L82J0L9777527	1
Whitehorse - Yukon	L278	—	—	L82U563000264	L82U263000268	4
Whitehorse - Yukon	L423	—	—	L82U983000481	L82U083000482	2
Whitehorse - Yukon	L563	38	41	L82U3A3000255	L82U9A3000258	4
Whitehorse - Yukon	L784	43	43	L82U9D3001057	L82U9D3001057	1
Whitehorse - Yukon	LA04	—	—	L82J2G3750390	L82J4G3750391	2
Whitehorse - Yukon	LB03	—	—	L82J9H9776352	L82J0H9776353	2
Windsor - Ontario	L186	555	564	L82U053000181	L82U453000190	10
Windsor - Ontario	LB24	8025	8026	L82JXJ3751424	L82J1J3751425	2
Windsor Ontario - Metrolinx	L886	570	577	L82J8F3001818	L82J5F3001825	8
Windsor Ontario - Metrolinx	LA56	578	601	L82J5J3751007	L82J0J3751030	24
Windsor Ontario - Metrolinx	LC21	8027	8045	L82J3L9777540	L82J0L9777558	19
Woodstock - Ontario	L255	—	—	L82U163000228	L82U163000228	1
Woodstock - Ontario	L335	—	—	L82U083000093	L82U083000093	1
Woodstock - Ontario	L419	—	—	L82U183000409	L82U183000409	1
Woodstock - Ontario	L460	—	—	L82U693000309	L82U693000309	1
Woodstock - Ontario	L492	—	—	L82U4A3000040	L82U6A3000041	2
Woodstock - Ontario	L778	—	—	L82U2D3001014	L82U2D3001014	1
Woodstock - Ontario	L832	—	—	L82J9E3001342	L82J9E3001342	1
Woodstock - Ontario	L923	15-16	15-16	L82J9F3001746	L82J9F3001746	1
Woodstock - Ontario	LA08	17-08	17-08	L82J3H3750514	L82J3H3750514	1

CLIENT	ORDER	ROAD NUMBER		VIN (2NVY/4RKY...)		QTY
		FROM	TO	FROM	TO	
Woodstock - Ontario	LB04	18-04	18-14	L82J3H9776363	L82J5H9776364	2
Woodstock - Ontario (ref. L388)	L209	—	—	L82U153000230	L82U153000230	1
York Regional Transit - Ontario	L562	1080	1082	S92U2A3000420	S92U6A3000422	3
York Regional Transit - Ontario	L572	1083	1094	S92U3A3000569	S92U2A3000580	12
York Regional Transit - Ontario	L654	1370	1390	S92U1D3000946	S92U2D3000986	21
York Regional Transit - Ontario	L761	1391	1396	S92U6D3001008	S92UXD3001013	6
York Regional Transit Ontario - Metrolinx	L896	1501	1517	L82J2F3001619	L82JXF3001741	17
York Regional Transit Ontario - Metrolinx	L936	1518	1518	L82J3G3750012	L82J3G3750012	1
York Regional Transit Ontario - Metrolinx	L967	1601	1621	L82J2G9775414	L82J8G9775627	21
York Regional Transit Ontario - Metrolinx	LA07	1701	1715	L82J9G3750340	L82JXG3750363	15
York Regional Transit Ontario - Metrolinx	LC24	1971	1980	S92J0K3752110	S92J3K3752120	10
York Regional Transit Ontario - Metrolinx	L964	1770	1774	S92J6G3750420	S92J3G3750424	5



**WARNING**

Follow your internal safety procedures.

**PROCEDURE**

- 1.1. Park the vehicle on an even surface with transmission on neutral (N).
- 1.2. Apply the parking brake.
- 1.3. Set the master control switch to the STOP position (see figure 1).

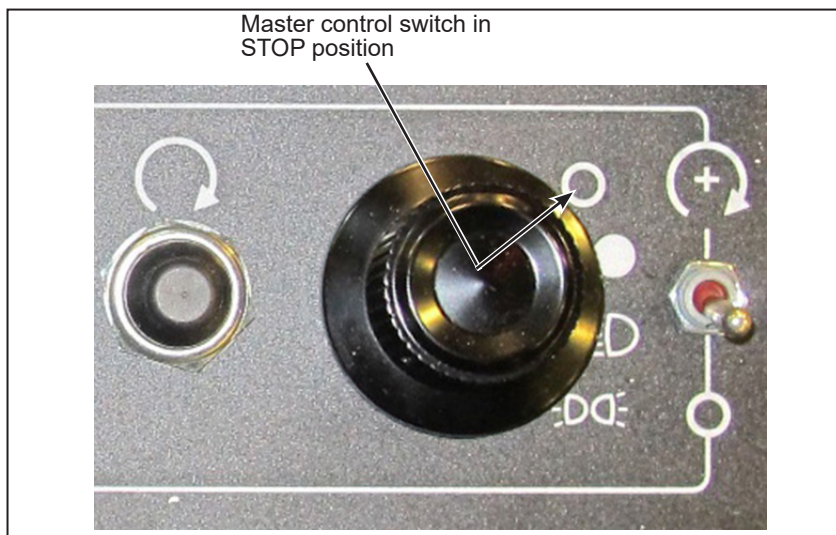

*Figure 1 - Master Control Switch in STOP Position*

- 1.4. Set the battery disconnect switch in the battery compartment to the OFF position (see figure 2).

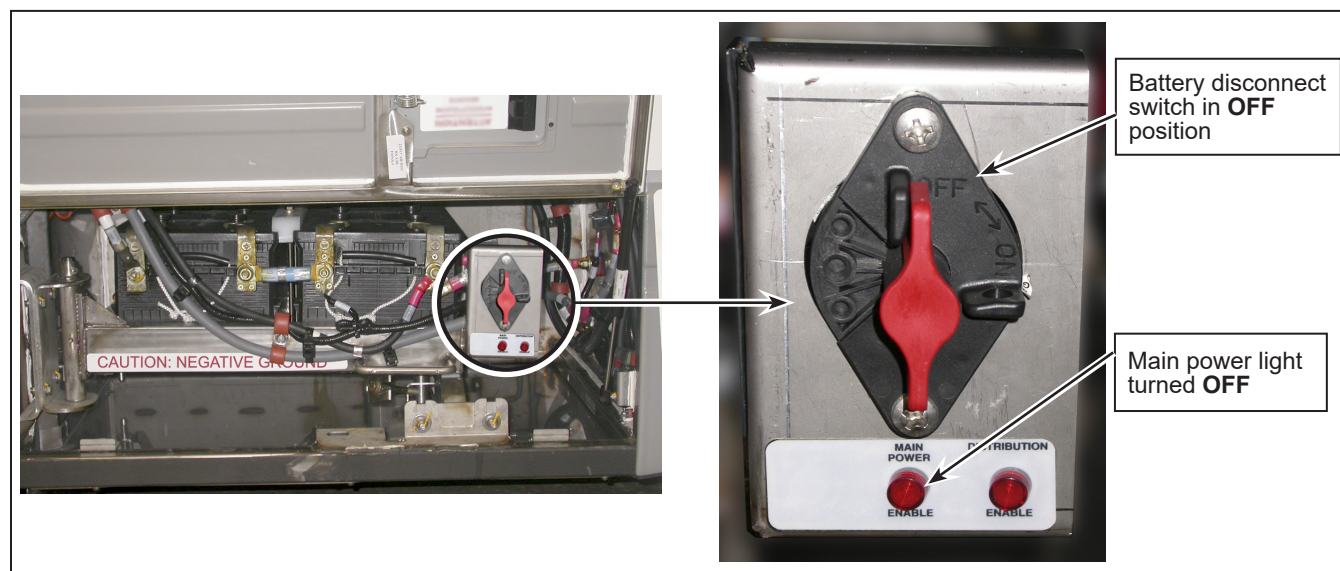
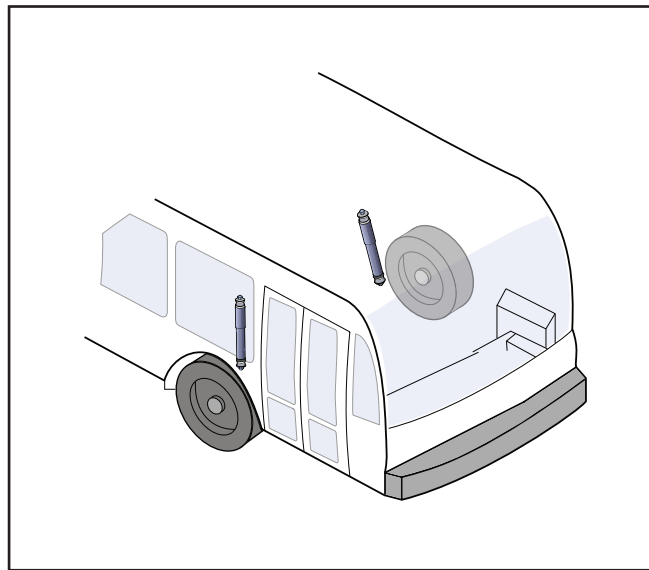

*Figure 2 - View of Battery Disconnect Switch*

**WARNING**

When replacing shock absorbers on any axle, it is imperative that **STANDARD** and **IMPROVED RIDE** shock absorbers are only installed with matching component parts. They must **NOT** be mixed on the same axle.

Verify the Nova Bus Parts Book to ensure that identical, factory-installed part numbers for air springs and shock absorbers are installed.



*Figure 3 - Location of Front Shock Absorbers*

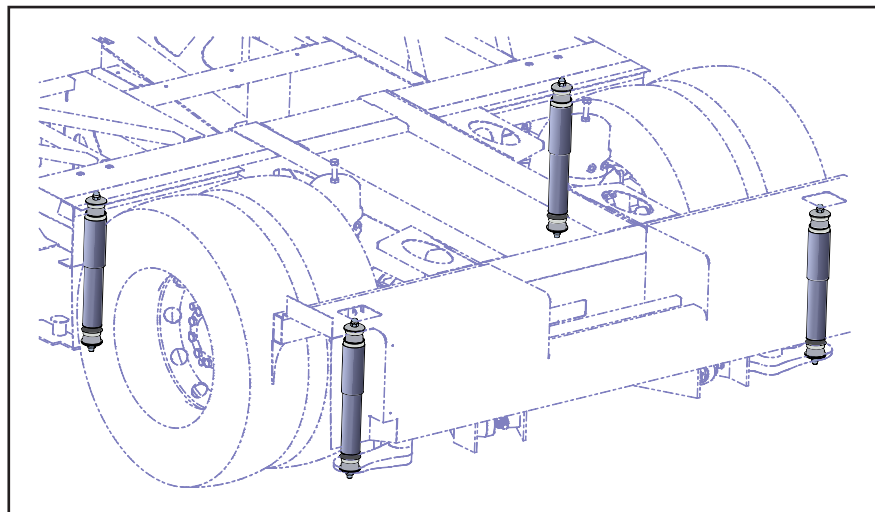

*Figure 4 - Location of Rear Shock Absorbers*

**NOTE**

Do not force the shock absorber into place. The use of force indicates that there is a problem with the alignment.

- 1.5. Wear marks on axle casting from bushing moving (see figure 6).



*Figure 5 - Wear Marks on Axle*

- 1.6. The center portion of the bushing does not fit the bore in the axle properly (see figure 7).



*Figure 6 - Bushing Incorrect Fit in the Axle*

**ACTUAL INSTALLATION**

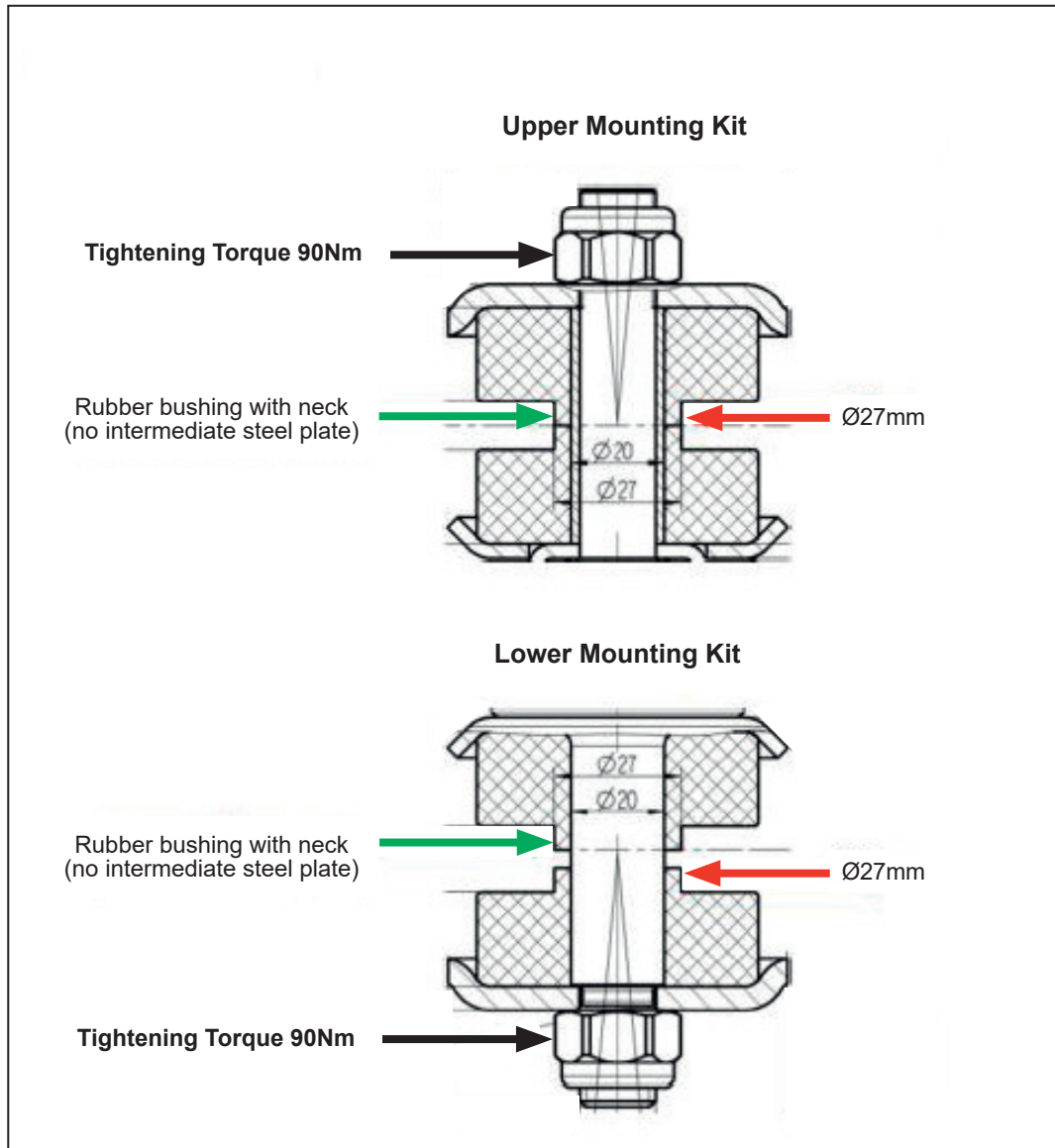

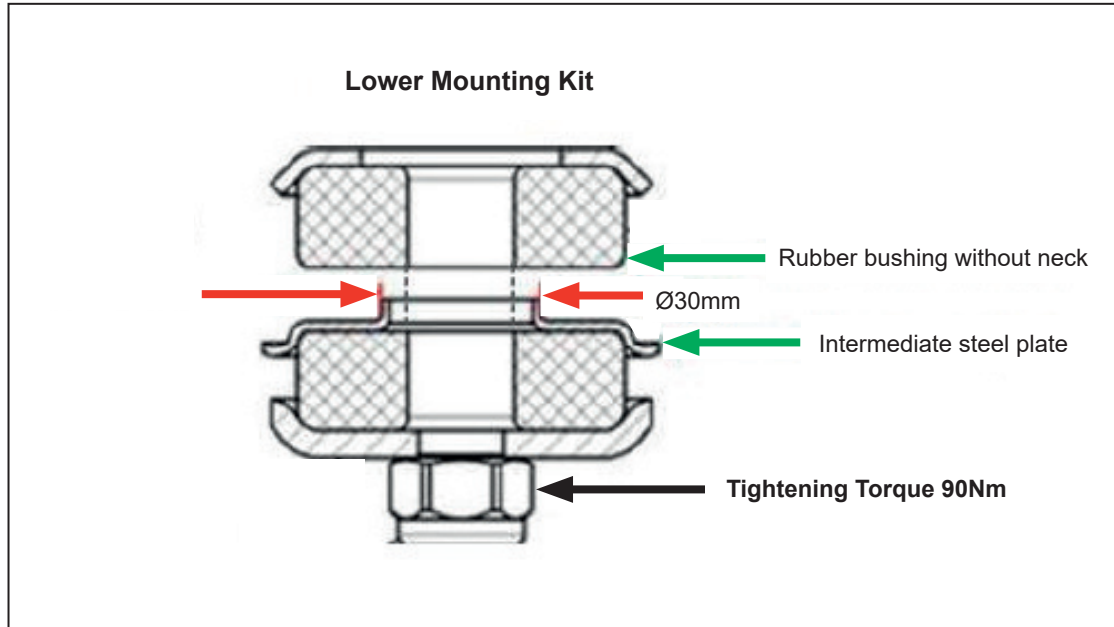
**NEW CONFIGURATION**

**Note:** The Change Will apply for all part numbers shown below.

**40' Non-articulated and 60' articulated LFS Bus. (3rd generation)**

- N39730 (ZF p/n 481700000499) – Front Shock Absorber --> released in 2006
- N35179 (ZF p/n 481700000492) – Rear Shock Absorber --> released in 2006

**40' Non-articulated and 60' articulated LFS Artic Bus (4rd generation)**

- N56224 (ZF p/n 48170005951) – Front Shock Absorber --> released in 2009
- N56226 (ZF p/n 48170005952) – Rear Shock Absorber --> released in 2009

1.7. Return the bus to service.❖