

4700  
4800  
4900

5700  
6900  
> 49X

## General Information

Cab load disconnect switches (CLDS), also known as positive load disconnect, installed on selected vehicles can reduce battery drain when the vehicle is not operational.

This service bulletin provides installation procedures for in-cab switch installation.

## Parts

**Table 1** lists the parts for in-cab installation of the CLDS switch.

In-Cab Installation Parts List		
Part Number	Description	Quantity
A66-01937-000	Harness (BCA to cutoff switch)	1
See <b>Table 2</b> for part number.	Battery Cable Access (BCA)	1
A06-88420-000	Battery Cutoff Switch/Battery Load Disconnect Switch	1
23-12509-420	NUT-INSERT, M6X1.00,KNR	4
23-13488-040	SCR-MACH, RHWC, HDI, DGPT, M6X1.0X	4
24-01618-002	LABEL-NOTICE, BATTERY DRAW	1
24-01594-000	LABEL-CUTOFF SWITCH	1
—	Fabric Abrasion Tape	As needed
—	Cable Ties	As needed

**Table 1, In-Cab Installation Parts List**

## Vehicle Preparation

Perform the following steps to prepare the vehicle for switch installation.

1. Park the vehicle, shut down the engine, and apply the parking brakes. Chock the tires.
2. Disconnect the batteries.
3. Remove the three screws that attach the dash cover throttle to the dash and accelerator pedal assembly and remove the panel as shown in **Fig. 1**. For additional installation instructions, see **Group 60** in the *49X Workshop Manual*.

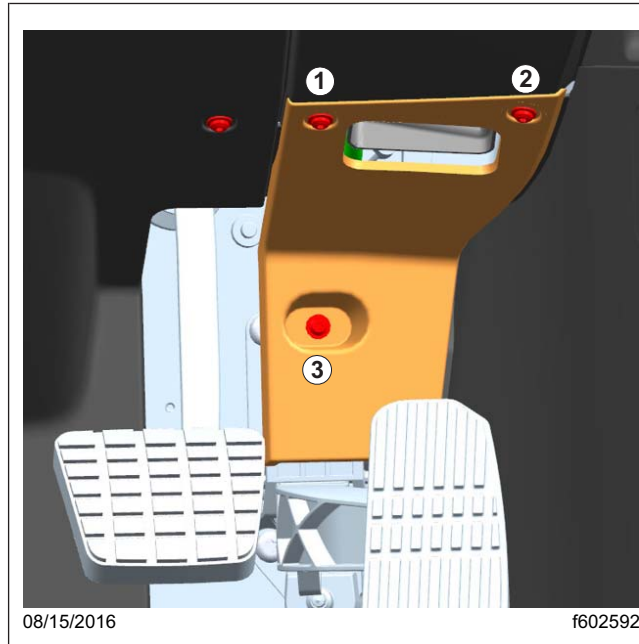

**Fig. 1, Throttle Panel Removal**

4. Remove the dash cover steering column kick panel as shown in [Fig. 2](#). For additional installation instructions, see **Group 46** in the *49X Workshop Manual*.

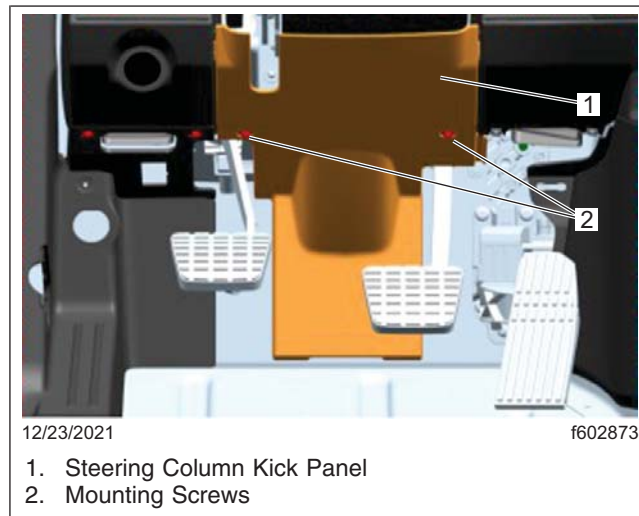

**Fig. 2, Steering Column Kick Panel**

5. Remove the electrical bay cover using the handhold at the lower left of the cover as shown in [Fig. 3](#).

4700  
4800  
4900

5700  
6900  
> 49X

Western Star  
Service Bulletin

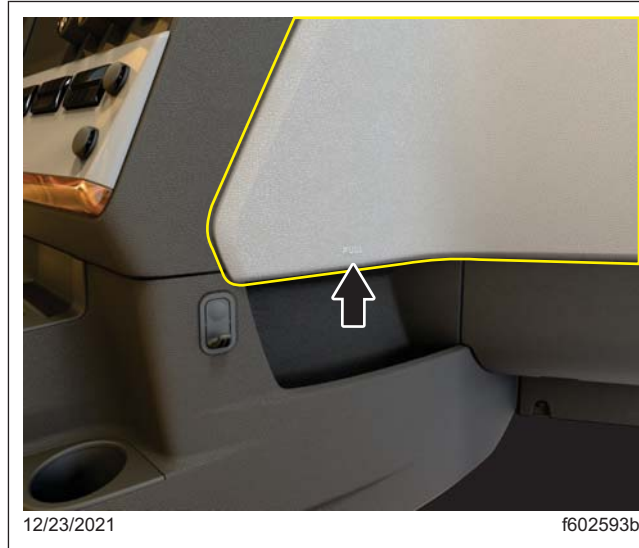

**Fig. 3, Electrical Bay Cover Handhold**

6. Remove the seven screws that attach the cover to the dash as shown in [Fig. 4](#), then pull the clips loose and remove the cover.

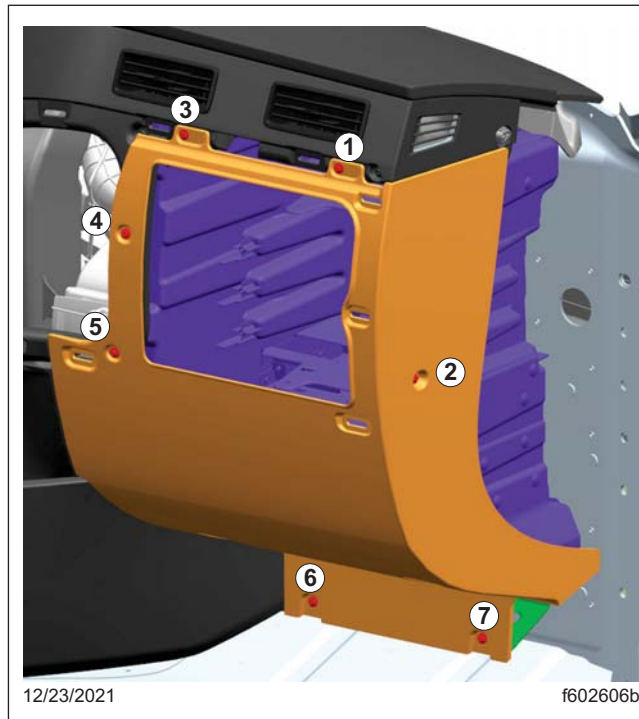

**Fig. 4, Passenger Side Lower Dash Cover**

7. Remove the existing battery cable access (BCA). Refer to **Group 54** and **Group 60** of the *49X Workshop Manual* for instructions.
8. Install the new BCA.

NOTE: When installing the battery cables on the BCA battery studs, apply a drop of LOCTITE® Blue 242 to the area of the studs the tightened nuts will overlap. Install the washers and the nuts. Hold the end of each stud with vice grip pliers as shown in **Fig. 5** and tighten each nut with a 13 mm box end wrench to secure the cable to the BCA. Tighten the nuts 10.3 to 11.8 lbf·ft (15±1 N·m).

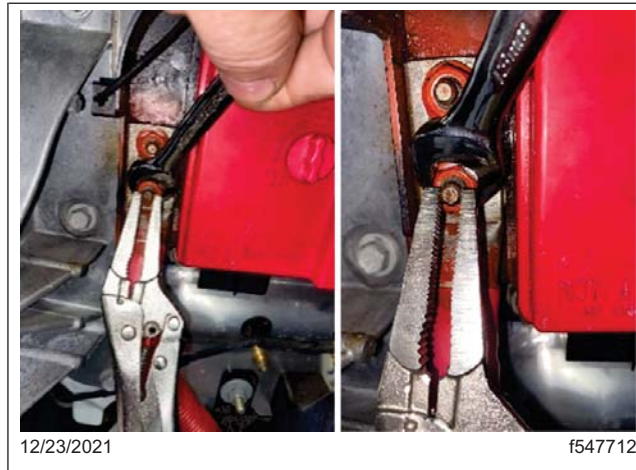

**Fig. 5, Gripping the Stud to Tighten the Nut**

## Harness Installation

This section provides instructions for in-cab battery cutoff switch harness installation.

1. Wrap the entire length of the new harness (part number A66-01937-000) with fabric abrasion tape.
2. Route the new harness along the main cab harness as shown in **Fig. 6**. Route the harness from the BCA box to the front wall grommet located above and to the left of the steering wheel as shown in **Fig. 7**. Use cable ties to secure the new harness to the main cab harness, as needed.

4700  
4800  
4900

5700  
6900  
> 49X

Western Star  
Service Bulletin

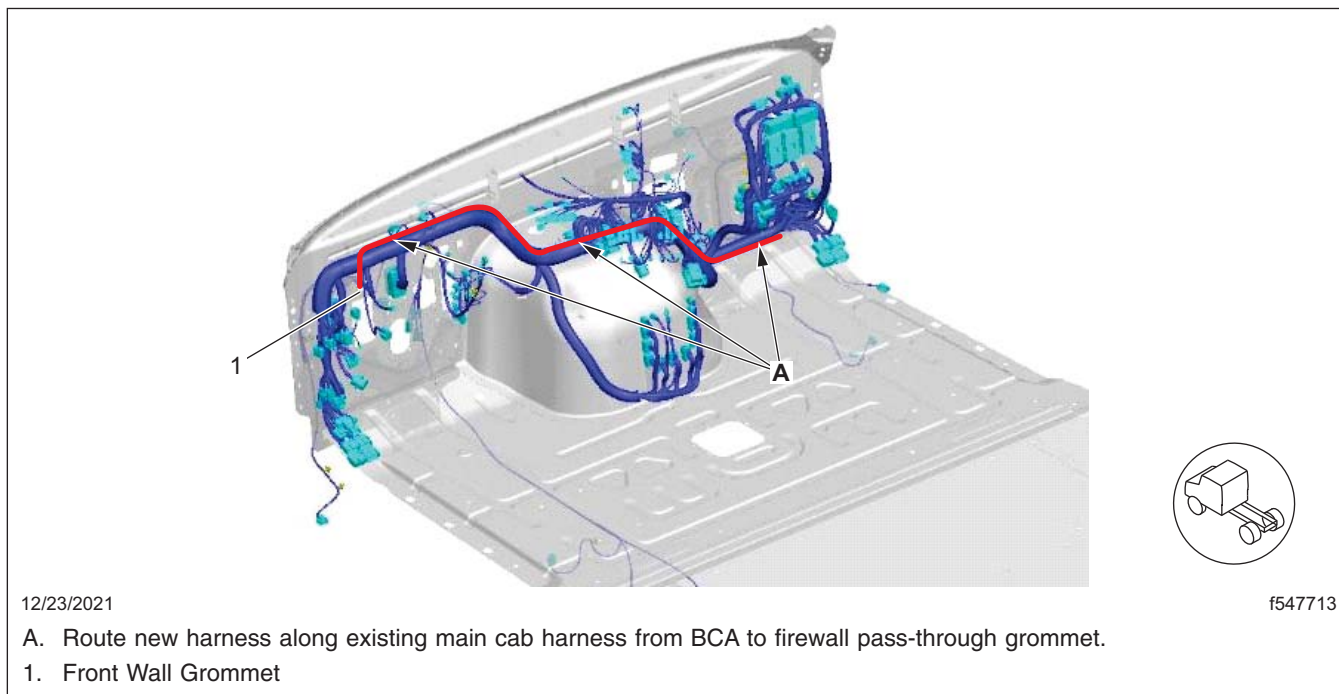

**Fig. 6, New BCA Harness Routing**

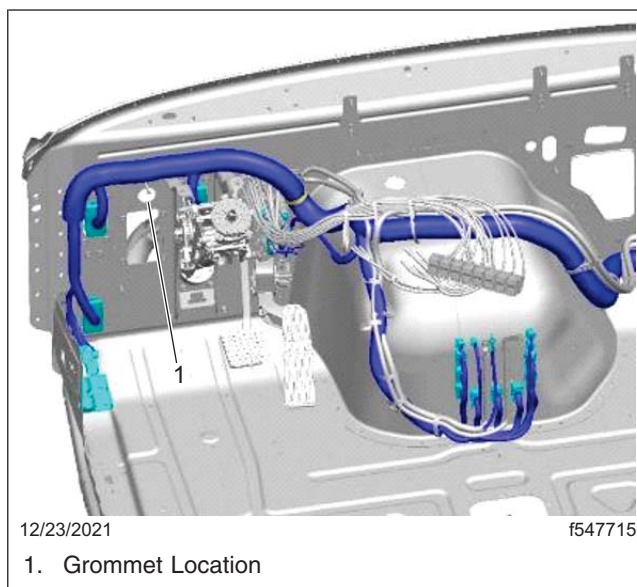

**Fig. 7, Firewall Pass-through Grommet**

3. Connect the new harness to the BCA in the location shown in **Fig. 8**.

BCA harness connection details are shown in **Fig. 9**.

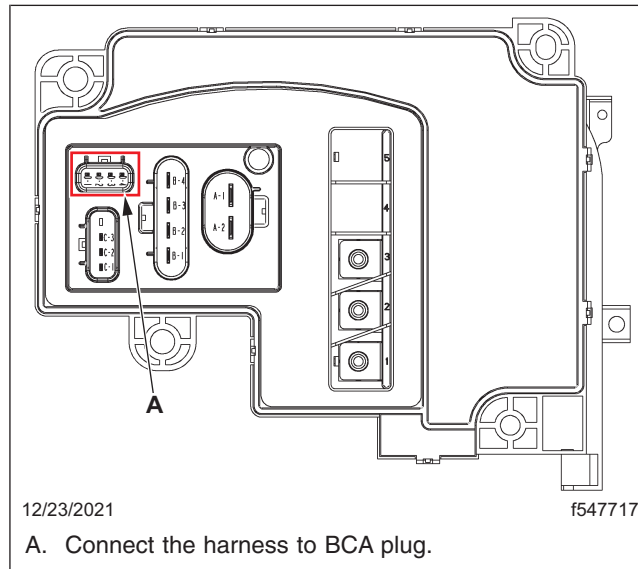

**Fig. 8, BCA Harness Connector**

ID:	BAT_DASH_O_BCA_D_1A
PN:	23-13153-401
	SEALED CONNECTOR
CAV	CIR#
—	—
1	425M # 1103 (T-W)
2	425N # 1103 (T-W)
3	425L # 1103 (T-W)
4	425P # 1103 (T-W)

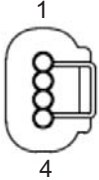

01/10/2022 f547716

**Fig. 9, BCA Harness Connection Details**

- Temporarily remove the connector, shown in **Fig. 10**, from the battery load disconnect switch end of the new harness. Use tool DK10CHA17002-2 or similar to remove the terminals from the connector. Make note of the cavity position, shown in **Fig. 11**, for each wire for later installation.

See **Fig. 11** for battery load disconnect switch connector details.

4700  
4800  
4900

5700  
6900  
> 49X

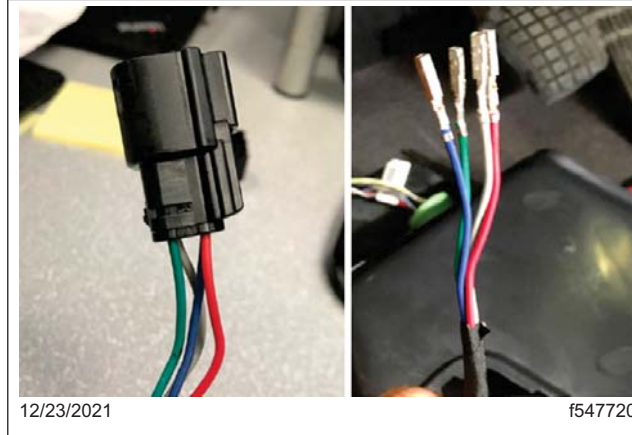

**Fig. 10, Battery Load Disconnect Switch Connector**

ID:	BAT_DASH_O_SW_BAT_DISC_1A
PN:	23-13662-401
	SEALED CONNECTOR
CAV	CIR#
—	—
1	425L # 1103 (T-W)
2	425M # 1103 (T-W)
3	425P # 1103 (T-W)
4	425N # 1103 (T-W)

12/23/2021 f547714

**Fig. 11, Battery Load Disconnect Switch Connector, Cavity Positions**

5. Locate the firewall pass-through grommet on the driver's side of the cab and remove the cable tie from the grommet on the engine side of the firewall as shown in [Fig. 12](#).

NOTE: A large section of tape on the cab side of the harness may need to be removed before installing the new harness.



**Fig. 12, Firewall Grommet and Cable Tie**

6. Insert a large cable tie through the grommet from the engine side of the firewall into the cab. The cable tie will be used to pull the harness through the firewall.

NOTE: Lubricate the end of the cable tie with WD-40 or a similar lubricant before inserting the cable tie through the grommet. If the cable tie is too large to pass through, insert a lubricated screwdriver to help open up a path for the cable tie to pass through the grommet as shown in [Fig. 13](#). Be careful not to damage the wiring.

4700  
4800  
4900

5700  
6900  
> 49X

Western Star  
Service Bulletin



**Fig. 13, Screwdriver Inserted to Assist with Passing Through the Cable Tie**

7. Tape the end of the harness to the cable tie under the dash as shown in [Fig. 14](#).

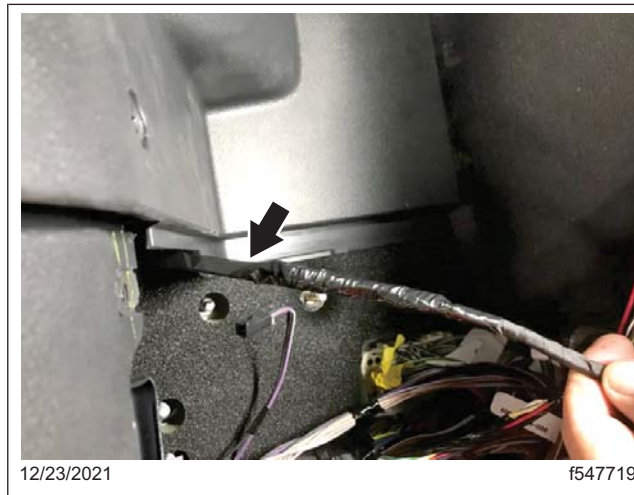

**Fig. 14, End of Harness Taped to Cable Tie Inserted Through Grommet**

8. Apply a small amount of WD-40 or similar lubricant to the tape. From the engine side, use the cable tie to pull the end of the harness through the grommet as shown in [Fig. 15](#).

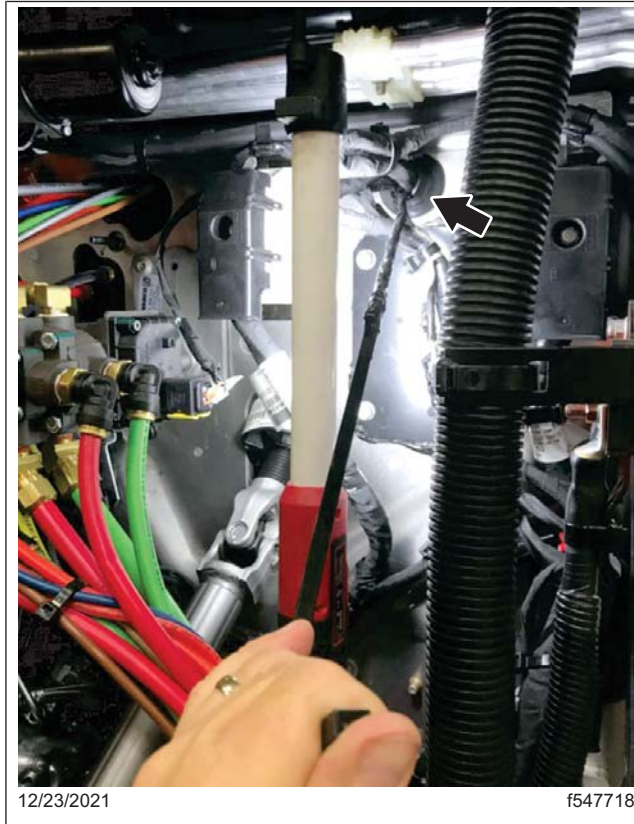

**Fig. 15, Pulling the Harness Through the Grommet**

9. After pulling the harness through the firewall grommet, install the connector removed from the battery load disconnect switch end of the new harness in step 4.

Make sure each wire is installed in the correct cavity position. See [Fig. 11](#).

10. If the vehicle is equipped with side fairings, remove the detachable side fairing on the driver's side for access under the cab to route the harness.
11. Route the harness from the firewall grommet down the driver's side front wall as shown in [Fig. 16](#), and then under the cab as shown in [Fig. 17](#), and then to the battery load disconnect switch location as shown in [Fig. 18](#). Secure the new harness with cable ties to the existing harnesses or airlines, as needed.

4700  
4800  
4900

5700  
6900  
> 49X

Western Star  
Service Bulletin

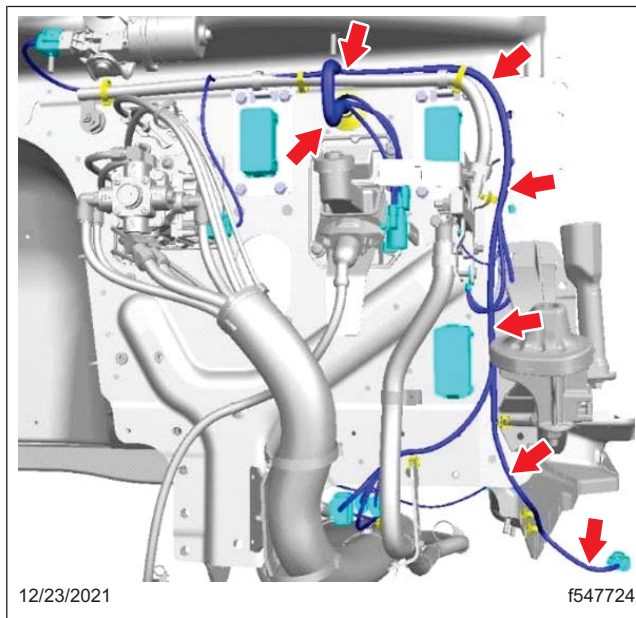

**Fig. 16, Harness Routing (driver's side)**

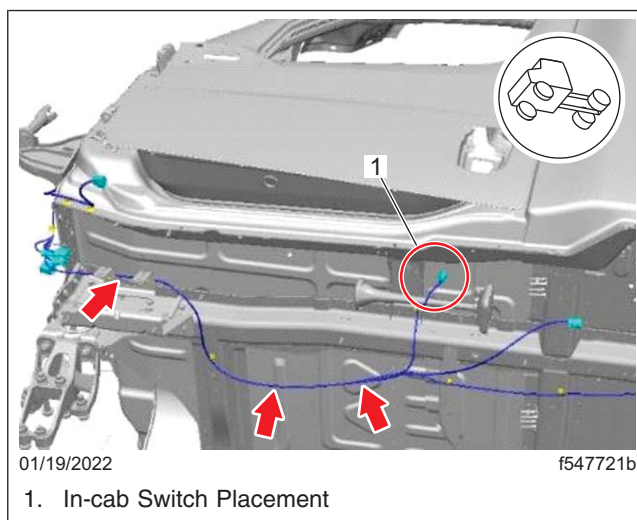

**Fig. 17, Harness Routing (under cab)**

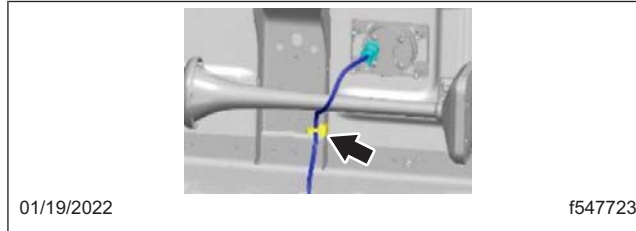

**Fig. 18, Harness Routing to Battery Load Disconnect**

12. Install the detachable side fairing.
13. Install the dash panels.

### Switch Installation

1. Remove the driver's side B-pillar trim panel and the driver's side door sill plate.
2. Lift the floor mat and find the floor panel indentations. These indentations mark where holes should be drilled for the battery load disconnect switch.
3. Drill holes for the battery load disconnect switch. See [Fig. 19](#) and [Fig. 20](#).
  - 3.1 Drill five pilot holes. Drill four holes for mounting fasteners and one large hole in the center for the switch. Use care not to drill into the horn. If necessary, remove the horn for additional clearance.
  - 3.2 Drill the center hole using a 2.5-inch hole saw, then use a carbide burr on a die grinder to clean the hole edges to install the switch.
  - 3.3 Use a 25/64-inch drill bit to drill the mounting fastener holes. See [Fig. 19](#).

NOTE: Loosen and reposition the driver's seat to gain better access to drill the holes for the switch.

4700  
4800  
4900

5700  
6900  
> 49X

Western Star  
Service Bulletin

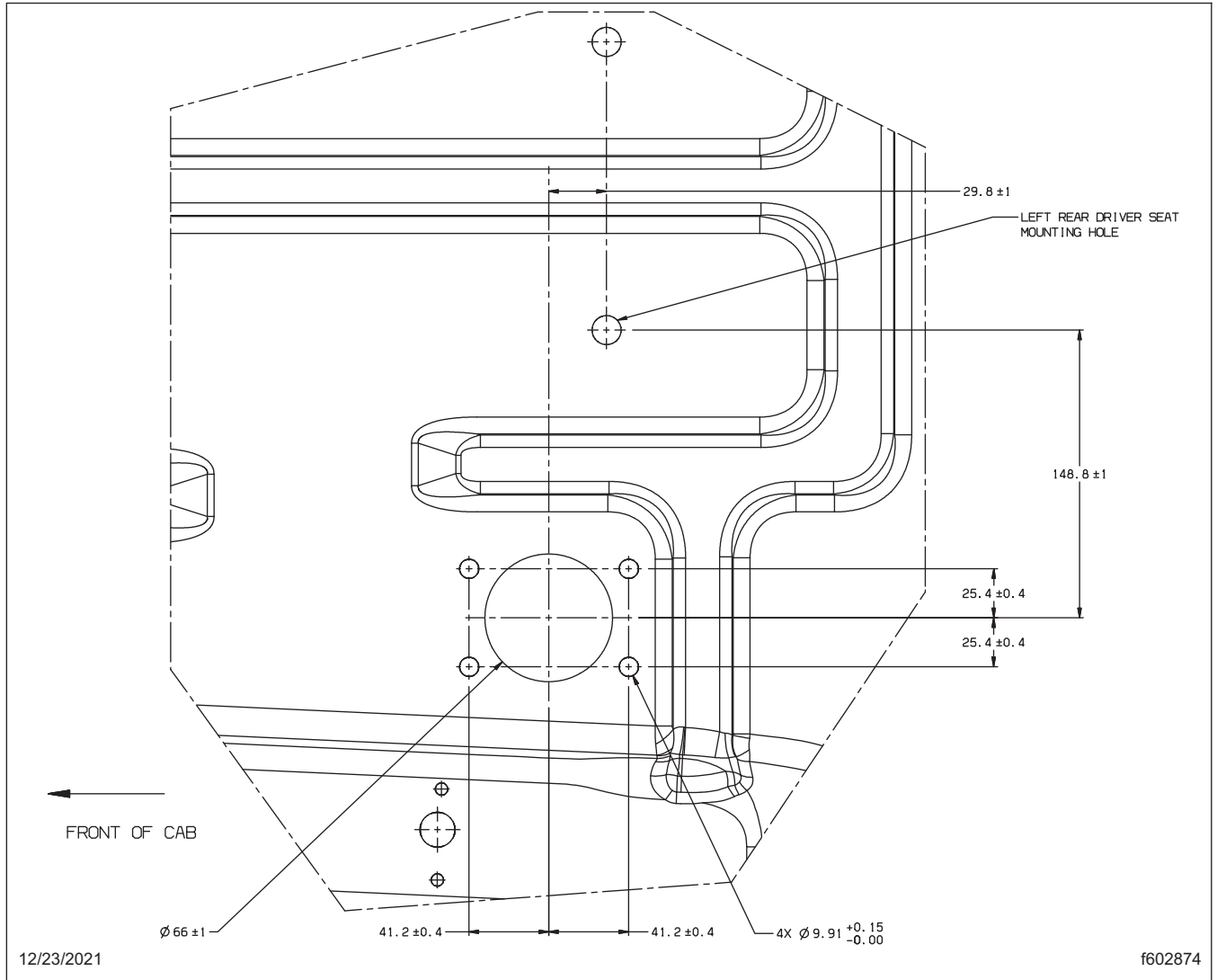

Fig. 19, Switch Drilling Diagram



**Fig. 20, Holes Drilled for Battery Load Disconnect Switch**

4. Install four nut inserts (part number 23-12509-420).
5. Trim the floor mat as shown in [Fig. 21](#) so that it tucks under the installed switch.



**Fig. 21, Trimmed Cab Floor Mat**

4700  
4800  
4900

5700  
6900  
> 49X

NOTE: Use the four mounting holes in the floor to mark and back-drill the floor mat. Then, using a razor knife, cut a rectangle in the floor mat about 1/8-inch past the rectangle formed by the four holes.

6. Install the battery load disconnect switch (part number A06-88420-000) with the four screws (part number 23-13488-040).
7. Connect the harness to the underside of the battery load disconnect switch.
8. Install the B-pillar trim panel and the door sill plate.
9. Connect the negative battery terminal.
10. Verify the operation of the battery load disconnect switch.

## Warning Label Application

After switch installation, apply the warning labels.

1. Apply the door jamb warning label (part number 24-01618-002) as shown in [Fig. 22](#).

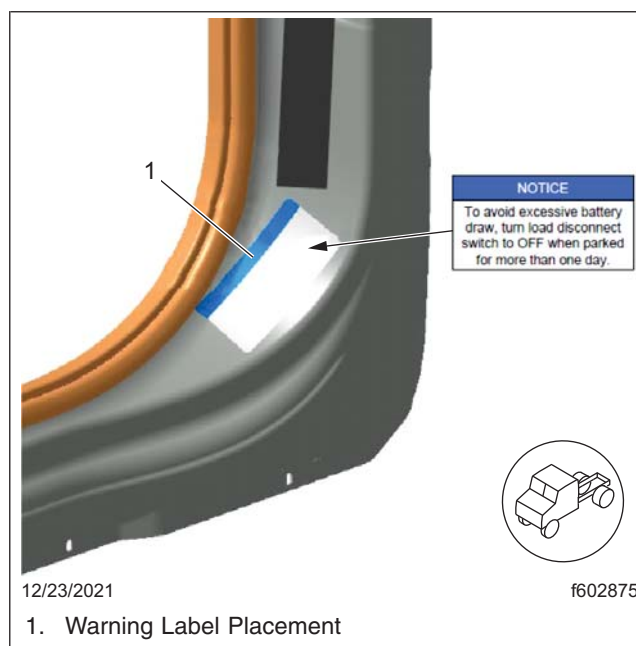

**Fig. 22, Door Jamb Warning Label**

2. Apply the frame rail warning label (part number 24-01594-000) as shown in [Fig. 23](#), on the outside centerline of the frame rail, in line with the starter power leads.

NOTE: Starters can be located on the right or left depending on the engine installed. [Fig. 23](#) shows the starter on the left side of the vehicle.

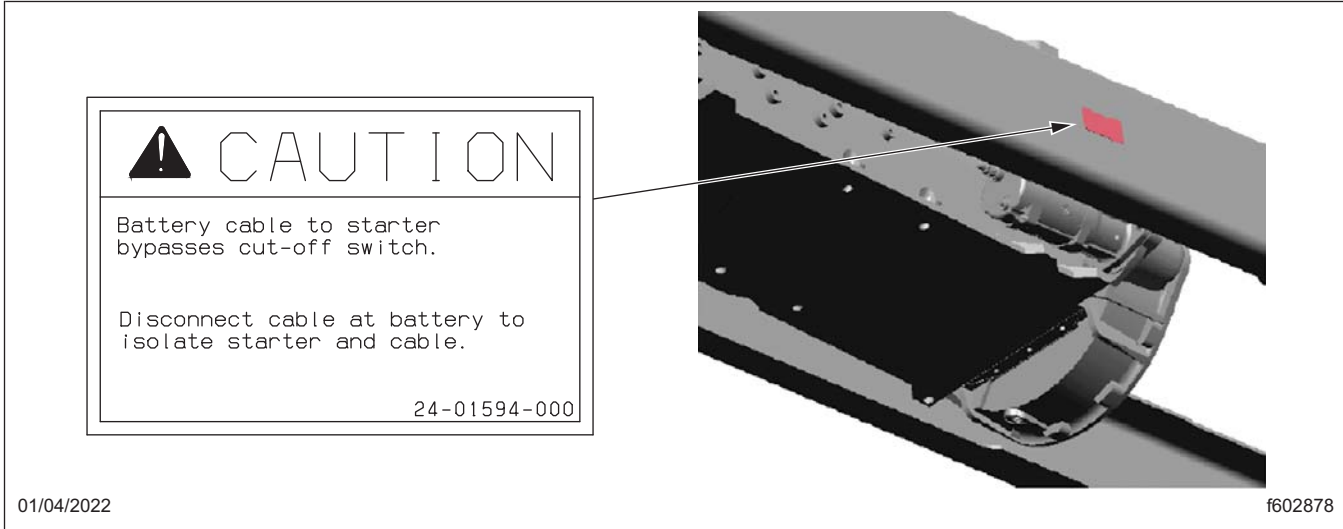

Fig. 23, Frame Rail Warning Label

### BCA Crossover List

BCA Crossover List		
Vehicle Model	BCA Without Contactor (no positive disconnect)	BCA With Contactor
49X	A66-01831-000	A66-19628-000
49X	A66-01863-000	A66-19628-001
49X	A66-01883-006	A66-19628-002
49X	A66-01883-007	A66-19628-003
49X	A66-01883-002	A66-19628-004
49X	A66-10292-003	A66-19628-005
49X	A66-10292-004	A66-19628-006
49X	A66-10292-002	A66-19628-007
49X	A66-10511-000	A66-19628-008
49X	A66-11730-003	A66-19628-009
49X	A66-11730-004	A66-19628-010
49X	A66-11730-002	A66-19628-011
49X	A66-11732-000	A66-19628-012
49X	A66-11734-006	A66-19628-013
49X	A66-11734-007	A66-19628-014
49X	A66-11734-002	A66-19628-015
49X	A66-18646-000	A66-19628-016
49X	A66-18648-000	A66-19628-017
49X	A66-18650-002	A66-19628-018
49X	A66-18650-003	A66-19628-019
49X	A66-18650-004	A66-19628-020

4700  
4800  
4900

5700  
6900  
> 49X

**Western Star  
Service Bulletin**

<b>BCA Crossover List</b>		
<b>Vehicle Model</b>	<b>BCA Without Contactor (no positive disconnect)</b>	<b>BCA With Contactor</b>
49X	A66-18652-002	A66-19628-021
49X	A66-18652-003	A66-19628-022
49X	A66-18652-004	A66-19628-023

**Table 2, BCA Crossover List**

## Warranty

This is an information bulletin only and not intended for pro-active work. Warranty does not apply.