

FLA COE
FLB COE
FLD Conventional
Business Class
FLC 112 Conventional

Century Class Conventional
Argosy
Cargo
Columbia
> 122SD and Coronado

> Business Class M2
> Cascadia
> 108SD/114SD
> New Cascadia

Freightliner
Service Bulletin

General Information

Some customers experience separation of the diesel exhaust fluid (DEF) lines from the connection ports in extreme cold temperatures. To prevent this, a process was developed to secure the lines with wire ties. A new reinforcement cap has been developed to simplify this process at the DEF connection fittings.

Vehicles built from January 2013 to January 2022 can be fitted with reinforcement caps on most DEF line connections. See [Table 1](#). DEF lines for vehicles equipped with Detroit engines, built from November 2018 to February 2020, have a different line design. For this date range, the original lines connecting the DEF tank to the pump, and doser to the tank, are not compatible with the reinforcement caps.

If a customer complains of DEF line separation resulting from freezing fluid, or if the vehicle is operated in areas with extreme cold conditions, the customer should consider making this update to prevent such issues in the future.

Installing the DEF Connector Reinforcement Cap

NOTE: For specific instructions on accessing the components listed below, see the applicable vehicle workshop manual.

NOTICE

If the vehicle has sustained a line separation resulting from frozen DEF, and the line is damaged, it must be replaced. Separate the line from the fitting (port), remove the white retaining clip, and inspect the line connector for damage. See [Fig. 1](#).



Fig. 1, Line Damage Resulting from Freezing DEF

1. 1. Remove the lines from the aftertreatment system (ATS) doser.
 - 1.1 Unlock the line connectors by pushing them onto the ports as far as possible. Then squeeze the ends of the white locking clip together.
 - 1.2 Remove each line.
2. Install the caps on the connectors on the opposite side from the locking clip. See [Fig. 2](#).

Freightliner Service Bulletin

FLA COE
FLB COE
FLD Conventional
Business Class
FLC 112 Conventional

Century Class Conventional
Argosy
Cargo
Columbia
> 122SD and Coronado

> Business Class M2
> Cascadia
> 108SD/114SD
> New Cascadia



Fig. 2, Reinforcement Cap Installation

3. Install the lines.
4. For vehicles equipped with a Detroit engine, remove the line from the left-hand (suction) port of the DEF pump.
5. Install the reinforcement cap on the connector. See [Fig. 3](#).



Fig. 3, Reinforcement Cap Installation

FLA COE
FLB COE
FLD Conventional
Business Class
FLC 112 Conventional

Century Class Conventional
Argosy
Cargo
Columbia
> 122SD and Coronado

> Business Class M2
> Cascadia
> 108SD/114SD
> New Cascadia

**Freightliner
Service Bulletin**

6. Install the suction port line.
7. Remove the line from the right-hand (supply) port of the DEF pump, install the reinforcement cap, and install the line.
8. Remove the line from the left-hand (supply) port of the DEF tank, install the reinforcement cap, and install the line.
9. Install any vehicle components removed to access the DEF lines.

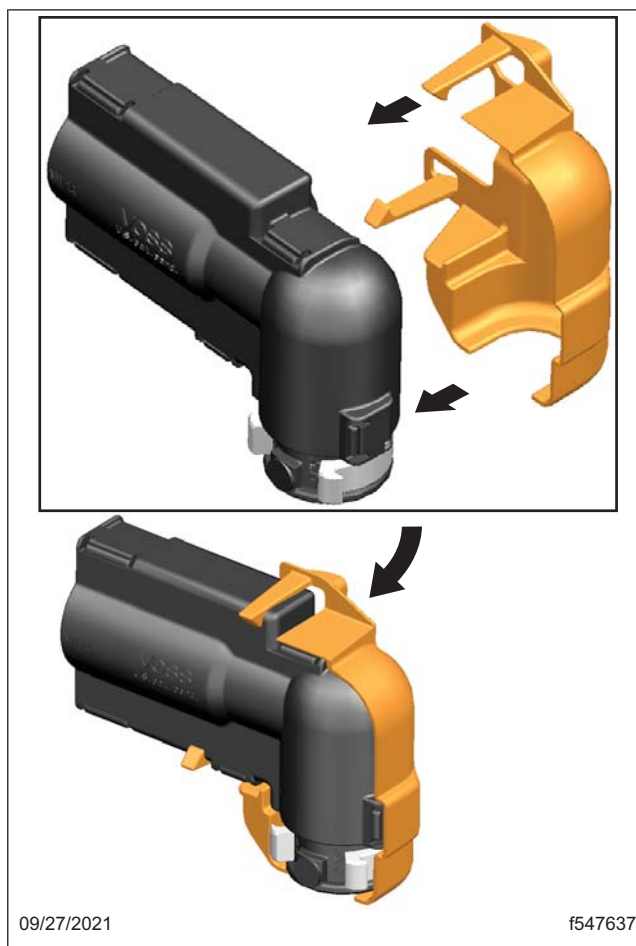

Fig. 4, Installing DEF Tank Reinforcement Cap

Freightliner Service Bulletin

FLA COE
FLB COE
FLD Conventional
Business Class
FLC 112 Conventional

Century Class Conventional
Argosy
Cargo
Columbia
> 122SD and Coronado

> Business Class M2
> Cascadia
> 108SD/114SD
> New Cascadia



Fig. 5, DEF Tank Reinforcement Cap Installed (reverse angle)

Parts

	Cap #1	Cap #2	Cap #3	Cap #4	Cap #5
					Picture Not Available
DTNA PN #	04-35740-122	04-35740-111	04-35740-211	04-35740-222	04-35740-221
Description	1/4_EPDM_RH	1/4_PA_LH	5/16_PA_LH	5/16_EPDM_RH	5/16_EPDM_LH

Fig. 6, DEF Connector Reinforcement Cap Kit Parts

DEF Reinforcement Cap Kit Numbers per Engine Type						
Location	Tank	Pump	Pump	Doser	Doser	Tank
Line	Suction	Suction	Pressure	Pressure	Return	Return
Detroit Fitting Size / Line Type / Clip Orientation	5/16_PA_LH	1/4_PA_LH	5/16_EPDM_RH	1/4_EPDM_RH	5/16_EPDM_LH	3/8_PA_RH
Reinforcement Cap Number	04-35740-211	04-35740-111	04-35740-222	04-35740-122	04-35740-211	N/A

DEF Connector Reinforcement Caps

49-042

FLA COE
 FLB COE
 FLD Conventional
 Business Class
 FLC 112 Conventional

Century Class Conventional
 Argosy
 Cargo
 Columbia
 > 122SD and Coronado

> Business Class M2
 > Cascadia
 > 108SD/114SD
 > New Cascadia

**Freightliner
 Service Bulletin**

Cummins Fitting Size / Line Type / Clip Orientation	5/16_EPDM_LH	3/8_EPDM_LH	5/16_EPDM_RH	1/4_EPDM_RH	5/16_EPDM_LH	3/8_EPDM_RH
Reinforcement Cap Number	04-35740-211	N/A	04-35740-222	04-35740-122	04-35740-211	N/A

Table 1, DEF Reinforcement CAP Kit Parts per Engine Type

Reinforcement Cap Part Numbers			
DTNA Part Number	Clip Type	Qty. Detroit	Qty. Cummins
04-35740-122	1/4_EPDM_RH	1	1
04-35740-111	1/4_PA_LH	1	N/A
04-35740-211	5/16_PA_LH	2	N/A
04-35740-222	5/16_EPDM_RH	1	1
04-35740-221	5/16_EPDM_LH	N/A	2

Table 2, Reinforcement Cap Part Numbers

Warranty

This is an informational bulletin only. Warranty does not apply.