

2022 Corolla Cross Pre-Delivery Service (PDS)

Service Category General

Section Pre-Delivery Service

Market USA

Toyota Supports
 ASE Certification 

Applicability

YEAR(S)	MODEL(S)	ADDITIONAL INFORMATION
2022	Corolla Cross	

REVISION NOTICE

January 12, 2022 Rev1:

- The Procedures and D/C Cut Fuse Installation sections have been updated.
- Any previous printed versions of this bulletin should be discarded.

Introduction

Pre-Delivery Service (PDS) is a critical step in satisfying our new car customers. Customer feedback indicates the following areas deserve special attention when performing PDS:

- Careful inspection for paint chips/scratches and body dents/dings.
- Proper operation of electrical accessories (including interior light, clock, and radio reset).
- Interior cleanliness.
- Proper function of mechanical systems.

Customer retention and proper maintenance of vehicles are and have always been a major focus for Toyota. To help remind customers that regular service is essential to the proper maintenance of the vehicle, dealers are required to install a service reminder sticker before delivery. By doing this, customers will be reminded to return to your dealership for service. Your current service reminder sticker may be used. (See PDS Check Sheet item 8 of “Final Inspection and Cleaning.”)

This bulletin contains the PDS procedures that apply specifically to 2022 model year Corolla Cross vehicles. A universal PDS [Check Sheet](#) that contains PDS steps that apply to all 2022 model year Toyota vehicles has been developed. To properly perform a complete PDS, you must complete all procedures contained in this TSB as well as the universal PDS [Check Sheet](#).

In addition, if the vehicle is stored for over 30 days, be sure to follow [Long-Term Vehicle Storage Guidelines](#).

2022 Corolla Cross Pre-Delivery Service (PDS)

Warranty Policy

If the need for additional repairs or adjustment is noted during PDS, the required service should be performed under warranty. Reimbursement will be managed under the warranty policy.

The Warranty Policy and Procedures Manual requires that you maintain the completed Check Sheet in the customer's file. If you cannot produce a completed form for each retailed vehicle upon TMS and/or Region/Distributor audit, the PDS payment amount will be subject to debit.

An additional Repair Order completed in conjunction with normal PDS MUST have time punch/flags for service. If multiple repairs are performed, separate time flags MUST be punched for each repair.

Warranty Information

OP CODE	DESCRIPTION	MODEL	TIME	OPF	T1	T2
001013	Pre-Delivery Service (PDS)	Corolla Cross	1.0	-	-	-

Required Tools & Equipment

REQUIRED EQUIPMENT	SUPPLIER	PART NUMBER	QTY
Techstream ADVi*	ADE	TSADVUNIT	1
Techstream 2.0		TS2UNIT	
Techstream Lite		TSLITEPDLR01	
Techstream Lite (Green Cable)		TSLP2DLR01	

*Essential SST.

NOTE

- Only ONE of the Techstream units listed above is required.
- Software version 16.30.011 or later is required.
- Additional Techstream units may be ordered by calling Approved Dealer Equipment (ADE) at 1-800-368-6787.

2022 Corolla Cross Pre-Delivery Service (PDS)

Procedures

- [D/C Cut Fuse Installation](#).....4
- [Memorize Steering Angle Neutral Point*](#)5
- [Front and Rear Emergency Towing Eyelet Removal and Hole Cover Installation](#)5
- [Front License Plate and Mounting Bracket Installation*](#)7
- [Installation of Rubber Body Plugs](#)9
- [Tire Pressure Warning System \(TPWS\) Initialization](#)10
- [Dealer Contact Information for Call Dealer Head Unit Function*](#)10
- [Entune™ 3.0 App Suite Connect Initialization/Update](#)10

*If applicable.

2022 Corolla Cross Pre-Delivery Service (PDS)

D/C Cut Fuse Installation

The D/C cut fuse (30A) has been removed at the assembly plant to reduce parasitic current draw in transit and storage. The removed D/C cut fuse (30A) is stored in the blank space of the relay block in the engine compartment. The D/C cut fuse (30A) **MUST** be reinstalled to the original location during PDS.

Figure 1.

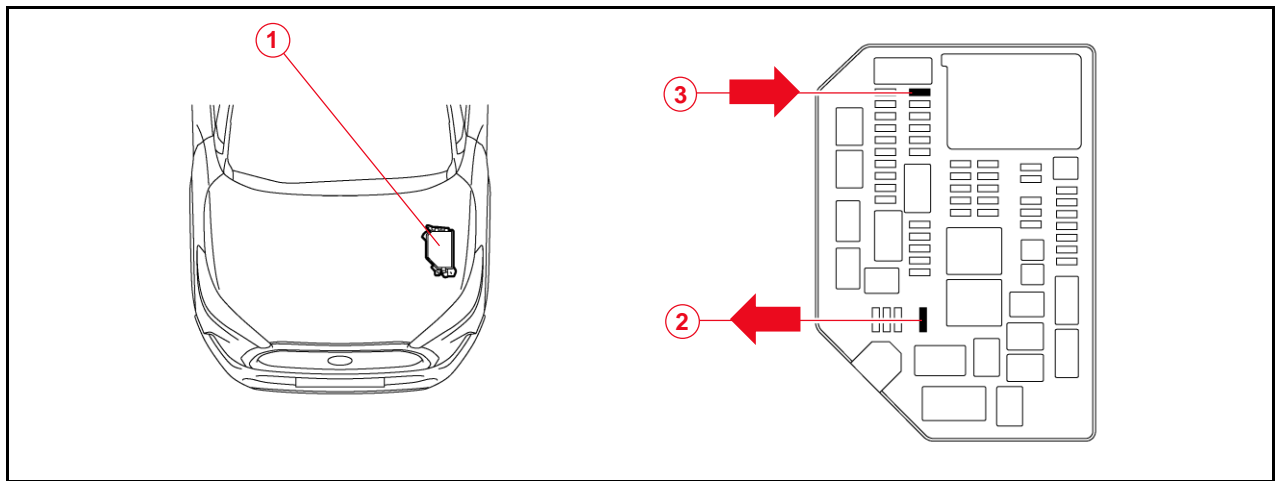

1	Relay Block
2	Remove D/C Cut Fuse (30A)

3	Install D/C Cut Fuse (30A) (Original Location)
---	------------------------------------------------

2022 Corolla Cross Pre-Delivery Service (PDS)

Memorize Steering Angle Neutral Point

As a result of the removal of the D/C cut fuse, the power source to the steering angle sensor is cut off. When the D/C cut fuse is reinstalled, the parking assist monitor system/panoramic view monitor system will be operative, but it cannot display guidelines to assist parking operation because the center position recognized by the steering angle sensor may not be in an initial position. Therefore, perform steering angle neutral point initialization AFTER installing the D/C cut fuse during PDS.

Refer to the applicable Repair Manual for the steering angle neutral point [initialization procedure](#).

Front and Rear Emergency Towing Eyelet Removal and Hole Cover Installation

1. Remove the front AND rear emergency towing eyelets from the front and rear bumpers by turning them counterclockwise.

NOTE

- If it is difficult to loosen the front emergency towing eyelet, use a steel bar.
- Dispose of the removed emergency towing eyelet.

Figure 2.

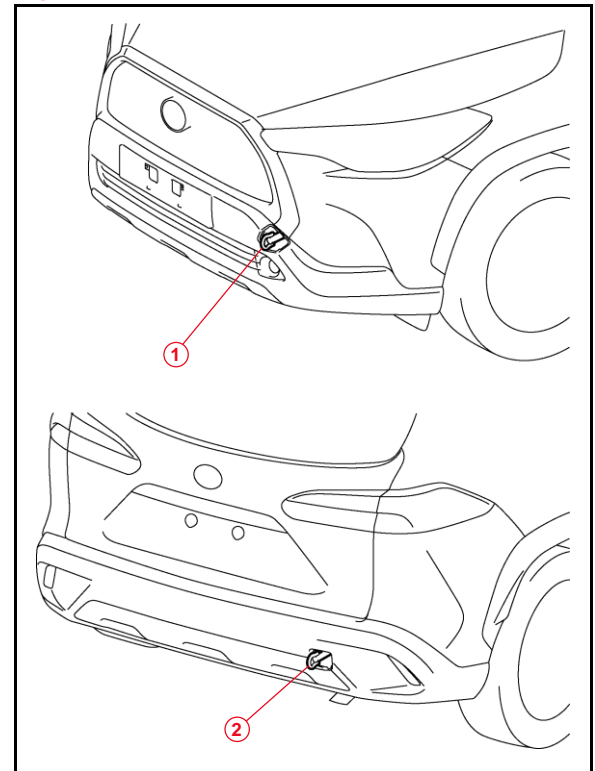

1	Front Emergency Towing Eyelet
2	Rear Emergency Towing Eyelet

2022 Corolla Cross Pre-Delivery Service (PDS)

Front and Rear Emergency Towing Eyelet Removal and Hole Cover Installation (continued)

2. Install the front AND rear emergency towing eyelet hole covers, which are stored in the glove compartment, onto the front and rear bumpers.

A. Insert the arrow-shaped part “A” of the front emergency towing eyelet hole covers into eyelet holes “B” as shown.

B. Install the front and rear emergency towing eyelet hole covers into the holes of the front bumper.

Figure 3.

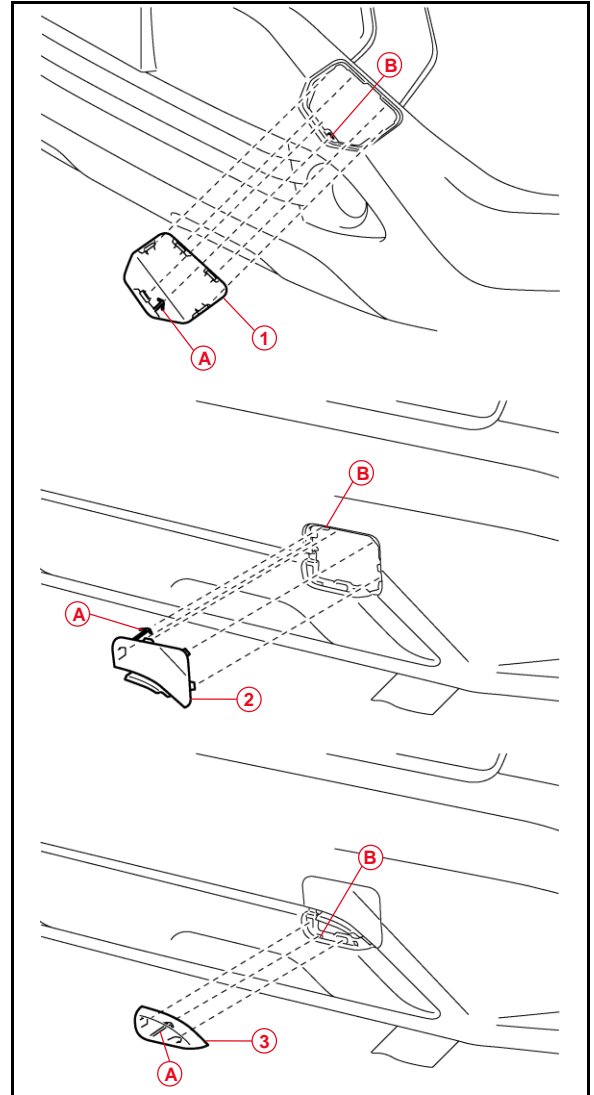

A	Arrow-shaped Part
B	Eyelet Hole
1	Front Emergency Towing Eyelet Hole Cover
2	Rear No. 1 Emergency Towing Eyelet Hole Cover
3	Rear No. 2 Emergency Towing Eyelet Hole Cover

2022 Corolla Cross Pre-Delivery Service (PDS)

Front License Plate and Mounting Bracket Installation

The front license plate bracket and two self-tapping screws are loaded in the luggage compartment at the assembly plant. Follow this procedure to install the front license plate bracket and front license plate in states where it is required by law.

1. Install the bracket rib into area "A" of the grille.
2. Press the front license plate bracket onto the grille until the clips engage.
3. Align the holes on the front license plate bracket with the dimples on the front of the grille.

Figure 4.

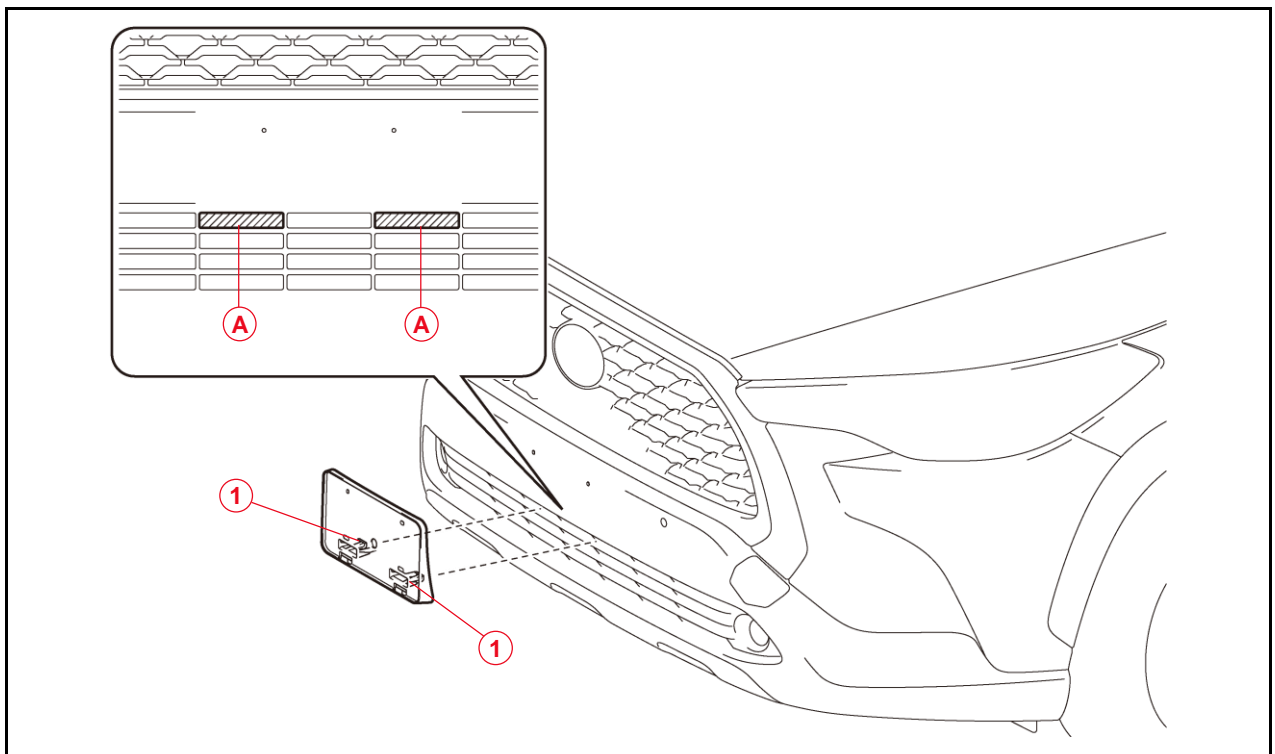

A	Area A
----------	---------------

1	Clip
----------	-------------

2022 Corolla Cross Pre-Delivery Service (PDS)

Front License Plate and Mounting Bracket Installation (continued)

4. Install two self-tapping screws through the holes on the front license plate, bracket, and lower grille.

NOTICE

- Do NOT pre-drill holes.
- Do NOT overtighten the self-tapping screws.

Figure 5.

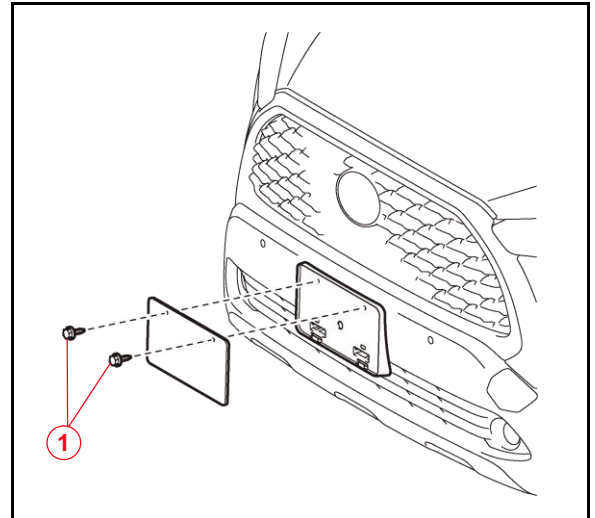

1	Self-tapping Screw
----------	---------------------------

2022 Corolla Cross Pre-Delivery Service (PDS)

Installation of Rubber Body Plugs

1. Confirm the number of plugs in the glove box. If two plugs are present, perform substep 2A ONLY. If four plugs are present, perform substep 2A AND substep 2B.
2. Install plugs according to the instructions below by confirming the number of plugs in the glove box.
 - A. Install two plugs in the rear side member hole or rocker inner hole as shown.
 - B. Install two plugs in the torque box hole or rocker inner hole as shown.

Figure 6.

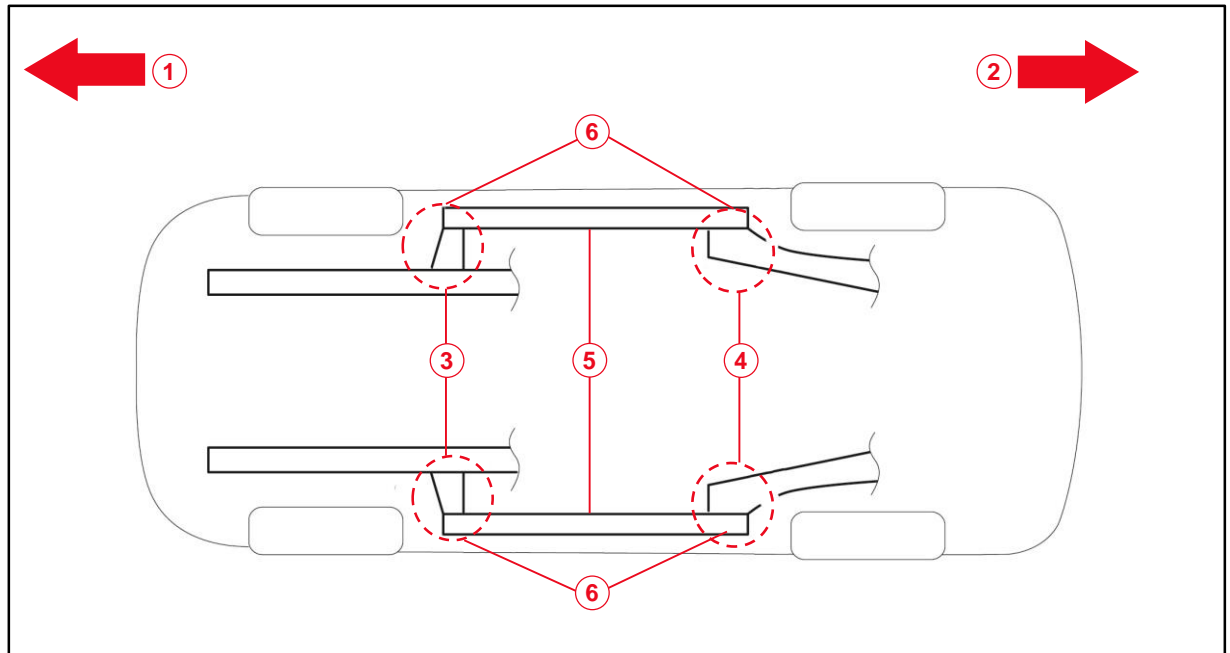

1	Front Side
2	Rear Side
3	Torque Box Hole or Rocker Inner Hole
4	Rear Side Member Hole or Rocker Inner Hole
5	Rocker Inner
6	Install Plug Here (if Applicable)

NOTICE

- The installation of these plugs is required to prevent rust.
- These plugs are stored in the glove box.
- The number of plugs may vary according to production locations in the same vehicle model.

2022 Corolla Cross Pre-Delivery Service (PDS)

Tire Pressure Warning System (TPWS) Initialization

Refer to the applicable Repair Manual for the TPWS [initialization procedure](#). Note the spare tire does NOT have a TPWS sensor.

NOTE

To adjust the tire pressure correctly when the outside temperature is significantly colder than shop temperature, perform a Health Check using Techstream and select the compensation tire pressure checkbox. Compensation pressures will display on the Health Check results screen. Adjust the tire pressure when the tires are cold.

Dealer Contact Information for Call Dealer Head Unit Function

Refer to the *Multimedia System Owner's Manual* to [add dealer contact information](#).

Entune™ 3.0 App Suite Connect Initialization/Update

Refer to [T-SB-0037-21](#) *Entune™ 3.0 App Suite Connect* to initialize/update the Entune™ 3.0 App Suite Connect head unit.