

2022 Camry, Camry HV Pre-Delivery Service (PDS)

Service Category General

Section Pre-Delivery Service

Market USA

Toyota Supports
 ASE Certification 

Applicability

YEAR(S)	MODEL(S)	ADDITIONAL INFORMATION
2022	Camry, Camry HV	

REVISION NOTICE

January 12, 2022 Rev1:

- The Procedures and D/C Cut Fuse Installation sections have been updated.
- Any previous printed versions of this bulletin should be discarded.

Introduction

Pre-Delivery Service (PDS) is a critical step in satisfying our new car customers. Customer feedback indicates the following areas deserve special attention when performing PDS:

- Careful inspection for paint chips/scratches and body dents/dings.
- Proper operation of electrical accessories (including interior light, clock, and radio reset).
- Interior cleanliness.
- Proper function of mechanical systems.

Customer retention and proper maintenance of vehicles are and have always been a major focus for Toyota. To help remind customers that regular service is essential to the proper maintenance of the vehicle, dealers are required to install a service reminder sticker before delivery. By doing this, customers will be reminded to return to your dealership for service. Your current service reminder sticker may be used. (See PDS Check Sheet item 8 of "Final Inspection and Cleaning.")

This bulletin contains the PDS procedures that apply specifically to 2022 model year Camry and Camry Hybrid vehicles. A universal PDS [Check Sheet](#) that contains PDS steps that apply to all 2022 model year Toyota vehicles has been developed. To properly perform a complete PDS, you must complete all procedures contained in this TSB as well as the universal PDS [Check Sheet](#).

In addition, if the vehicle is stored for over 30 days, be sure to follow [Long-Term Vehicle Storage Guidelines](#).

2022 Camry, Camry HV Pre-Delivery Service (PDS)

Warranty Policy

If the need for additional repairs or adjustment is noted during PDS, the required service should be performed under warranty. Reimbursement will be managed under the warranty policy.

The Warranty Policy and Procedures Manual requires that you maintain the completed Check Sheet in the customer's file. If you cannot produce a completed form for each retailed vehicle upon TMS and/or Region/Distributor audit, the PDS payment amount will be subject to debit.

An additional Repair Order completed in conjunction with normal PDS MUST have time punch/flags for service. If multiple repairs are performed, separate time flags MUST be punched for each repair.

Warranty Information

OP CODE	DESCRIPTION	MODEL	TIME	OFF	T1	T2
001013	Pre-Delivery Service (PDS)	Camry	1.0	-	-	-
		Camry HV	1.5			

Required Tools & Equipment

REQUIRED EQUIPMENT	SUPPLIER	PART NUMBER	QTY
Techstream ADVi*	ADE	TSADVUNIT	1
Techstream 2.0		TS2UNIT	
Techstream Lite		TSLITEPDLR01	
Techstream Lite (Green Cable)		TSLP2DLR01	

*Essential SST.

NOTE

- Only ONE of the Techstream units listed above is required.
- Software version 16.30.011 or later is required.
- Additional Techstream units may be ordered by calling Approved Dealer Equipment (ADE) at 1-800-368-6787.

2022 Camry, Camry HV Pre-Delivery Service (PDS)

Procedures

- [D/C Cut Fuse Installation](#) 4
- [Memorize Steering Angle Neutral Point*](#) 5
- [Steering Sensor Zero Point Calibration*](#) 5
- [Front Wheel Opening Extension Pad Installation](#) 6
- [Front License Plate and Mounting Bracket Installation*](#) 7
- [Installation of Rubber Body Plugs*](#) 8
- [Dealer Contact Information for Call Dealer Head Unit Function](#) 9
- [Entune™ 3.0 App Suite Connect Initialization/Update](#) 9

*If applicable.

2022 Camry, Camry HV Pre-Delivery Service (PDS)

D/C Cut Fuse Installation

To minimize battery discharge, the D/C cut fuse (25A) has been removed and is stored in the engine compartment relay block. Install the D/C cut fuse (25A) and confirm ALL related Diagnostic Trouble Codes (DTCs) are cleared.

Figure 1.

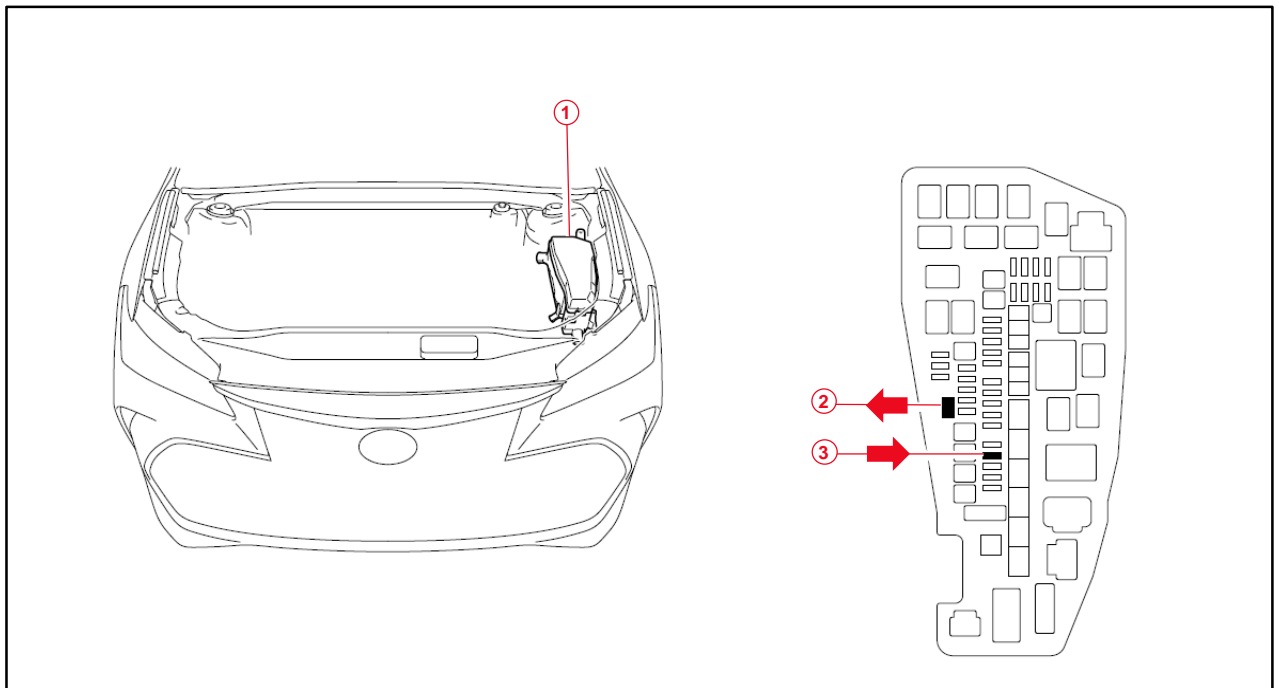

1	Relay Block
2	Remove D/C Cut Fuse (25A)
3	Install D/C Cut Fuse (25A)

2022 Camry, Camry HV Pre-Delivery Service (PDS)

Memorize Steering Angle Neutral Point

As a result of the removal of the D/C cut fuse, the power source to the steering angle sensor is cut off. When the D/C cut fuse is reinstalled, the parking assist monitor system/panoramic view monitor system will be operative, but it cannot display guidelines to assist parking operation because the center position recognized by the steering angle sensor may not be in an initial position. Therefore, perform steering angle neutral point initialization AFTER installing the D/C cut fuse during PDS.

Refer to the applicable Repair Manual for the steering angle neutral point initialization procedure ([Camry](#) / [Camry HV](#)).

Steering Sensor Zero Point Calibration

As a result of the removal of the D/C cut fuse, the steering angle sensor power source is cut off. When the D/C cut fuse is reinstalled, the center position recognized by the steering angle sensor may not be the appropriate position. Therefore, it is necessary to perform steering sensor zero point calibration AFTER installing the D/C cut fuse during PDS.

Refer to the applicable Repair Manual for the steering sensor zero point calibration procedure:

- Driving Method ([Camry](#) / [Camry HV](#)).
- Techstream Method ([Camry](#) / [Camry HV](#)) (procedure 4).

2022 Camry, Camry HV Pre-Delivery Service (PDS)

Front Wheel Opening Extension Pad Installation

The front wheel opening extension pad set (right and left front wheel opening extension pads) is loaded in the luggage compartment at the assembly plant to avoid damage in transit.

1. Remove the three self-tapping screws from the engine under cover (the self-tapping screws will be reused for installation).

HINT

The removed self-tapping screws are reused when installing the front wheel opening extension pad.

2. Place the left front wheel opening extension pad on the installation position as shown and tighten the three self-tapping screws.

HINT

There is a distinguishable mark on each pad.

3. Repeat steps 1 and 2 for the right-hand side.

Figure 2.

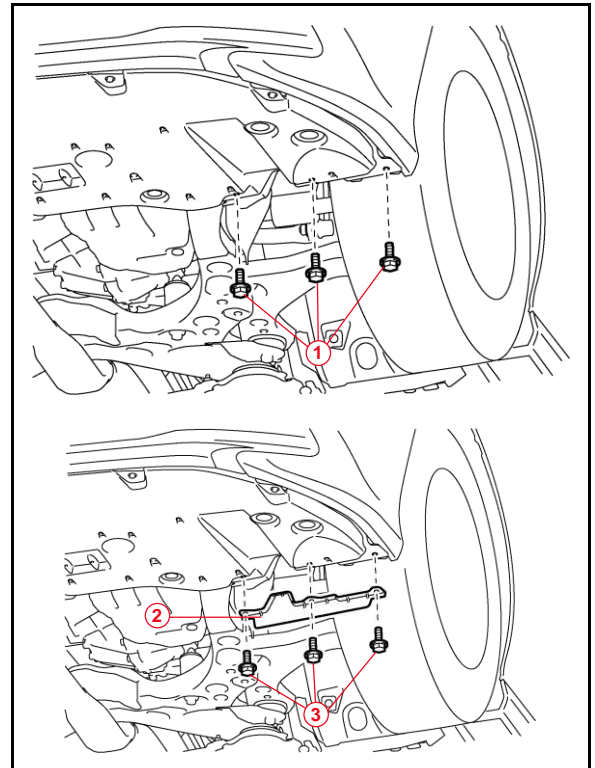

1	Remove Self-tapping Screw
2	Front Wheel Opening Extension Pad
3	Install Self-tapping Screw

2022 Camry, Camry HV Pre-Delivery Service (PDS)

Front License Plate and Mounting Bracket Installation

The front license plate mounting bracket set (front license plate mounting bracket, four long self-tapping screws, and two short self-tapping screws) is loaded in the luggage compartment at the assembly plant. Follow this procedure to install the front license plate bracket and front license plate in states where it is required by law.

1. Align the holes on the front license plate mounting bracket with the dimples on the front of the lower grille.
2. Install the two long self-tapping screws through the holes on the front license plate mounting bracket into the lower grille.

Long Self-tapping Screw: 37 mm (1.456 in.)

NOTICE

- Do NOT pre-drill holes into the bumper.
- Do NOT overtighten the self-tapping screws.

3. Insert the license plate into the tabs on the bracket.
4. Align the holes on the license plate with the corresponding holes of the front license plate mounting bracket.
5. Install the two short self-tapping screws through the holes on the front license plate mounting bracket and license plate.

Short Self-tapping Screw: 16 mm (0.630 in.)

NOTICE

- Do NOT pre-drill holes through the front license plate mounting bracket.
- Do NOT overtighten the self-tapping screws.

Figure 3.

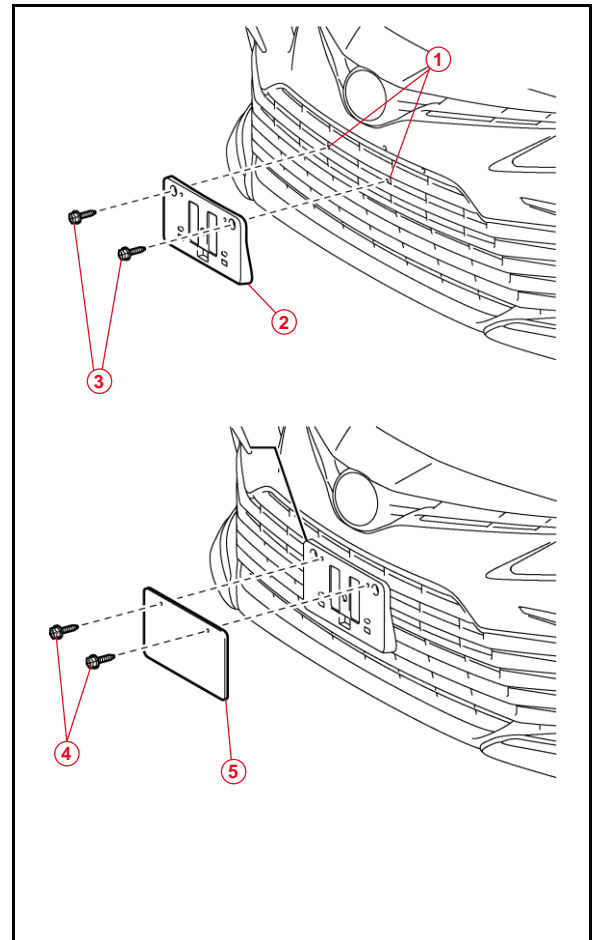

1	Dimple
2	Front License Plate Mounting Bracket
3	Long Self-tapping Screw
4	Short Self-tapping Screw
5	Front License Plate

2022 Camry, Camry HV Pre-Delivery Service (PDS)

Installation of Rubber Body Plugs

1. Confirm the number of plugs in the glove box. If two plugs are present, perform substep 2A ONLY. If four plugs are present, perform substep 2A AND substep 2B.
2. Install plugs according to the instructions below by confirming the number of plugs in the glove box.
 - A. Install two plugs in the rear side member hole or rocker inner hole as shown.
 - B. Install two plugs in the torque box hole or rocker inner hole as shown.

Figure 4.

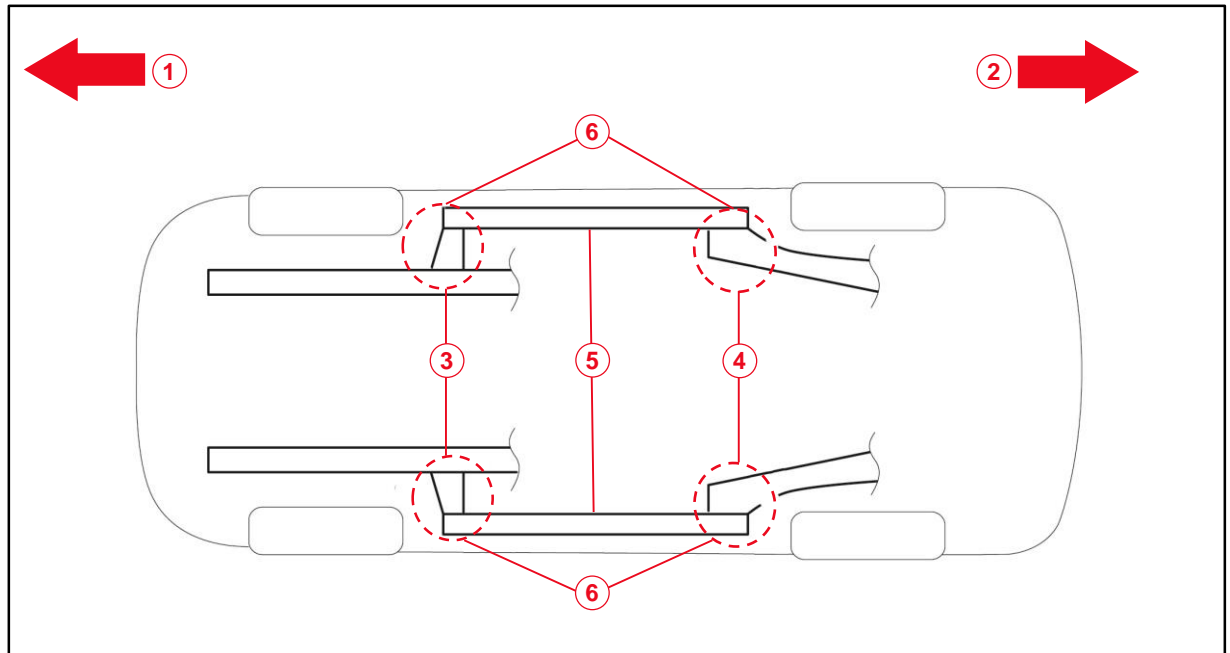

1	Front Side
2	Rear Side
3	Torque Box Hole or Rocker Inner Hole
4	Rear Side Member Hole or Rocker Inner Hole
5	Rocker Inner
6	Install Plug Here (if Applicable)

NOTICE

- The installation of these plugs is required to prevent rust.
- These plugs are stored in the glove box.
- The number of plugs may vary according to production locations in the same vehicle model.

2022 Camry, Camry HV Pre-Delivery Service (PDS)

Dealer Contact Information for Call Dealer Head Unit Function

Refer to the *Multimedia System Owner's Manual* to add dealer contact information ([Camry](#) / [Camry HV](#)).

NOTE

This step is not applicable to the following Camry models without optional audio:

- L
- LE
- SE
- TRD
- Nightshade

Entune™ 3.0 App Suite Connect Initialization/Update

Refer to [T-SB-0037-21](#) *Entune™ 3.0 App Suite Connect* to initialize/update the Entune™ 3.0 App Suite Connect.