

Classification:

BR00-005J

Reference:

ITB00-024J

Date:

January 27, 2022

BRAKE NOISE/JUDDER/PEDAL FEEL DIAGNOSIS AND REPAIR

This bulletin has been amended. See **AMENDMENT HISTORY** on page 10.
Please discard previous versions of this bulletin.

APPLIED VEHICLES: All Infiniti

SERVICE INFORMATION

This bulletin is to assist you in responding to client questions about brake operation, and provides diagnostic and repair information for each item listed, if any should occur.

Most brake issues fall into the following categories:

- a. **Brake Noise:** A squeak, squeal, clunk, or groan that occurs when the brakes are applied or released.
- b. **Brake Judder:** A vibration that can be felt in the vehicle, steering wheel, or brake pedal when the brakes are applied.
- c. **Pedal Feel:** The effort needed to operate the brakes is too high or too low.

SERVICE PROCEDURE

1. Verify the condition by interviewing the client and road testing the vehicle with the client.
 - Refer to the **Brake Noise Diagnostic Worksheet** on page 11 of this bulletin.
2. Determine the specific brake incident based on the description in the **SERVICE INFORMATION**, above.
3. Follow the appropriate repair procedure(s), listed on the following pages, for your specific incident.

Infiniti Bulletins are intended for use by qualified technicians, not 'do-it-yourselfers'. Qualified technicians are properly trained individuals who have the equipment, tools, safety instruction, and know-how to do a job properly and safely. NOTE: If you believe that a described condition may apply to a particular vehicle, DO NOT assume that it does. See your Infiniti retailer to determine if this applies to your vehicle.

BRAKE NOISE

Brakes can make a range of noises when applied or released. Some noises are normal and no repair action should be taken.

Use the following descriptions to identify the specific type of brake noise and the appropriate repair:

Squeak noise when the brakes are cold:

- Usually occurs during the first few stops in the morning.
- This is a normal condition. No service action is necessary.

Squeak noise with the brakes at normal operating temperatures:

- Refer to technical bulletins specific to the model of vehicle regarding this issue.
- If there are no bulletins for the car you are working on, install Original Equipment (OE) type pads using the information listed under **BRAKE SERVICE** on page 6 of this bulletin and the appropriate Electronic Service Manual (ESM) procedures.

Notes about brake pads and brake noise:

Original Equipment (OE) brake pads are installed on all current Infiniti vehicles at the factory.

- The OE pads use a Non-asbestos Organic (NAO) compound. The NAO material provides state of the art resistance to squeal noise.
- These pads are available as service parts and must be used if replacing brake pads under the terms of the Infiniti new car warranty.

Loud continuous squeak/squeal noise:

- Occurs with or without braking.
- This is a normal brake function. It occurs when the brake pad wear indicators contact the rotor.
- It indicates the brake pads are worn out and need to be replaced. Install new brake pads using the information listed under **BRAKE SERVICE** on page 6 of this bulletin and the appropriate ESM procedures.

Groan noise when slightly releasing the brakes after coming to a stop:

- This is sometimes called “creep groan”.
- It is a normal condition. No repair or service is necessary.

Groan noise during stopping:

- Usually caused by glazing of the rotor’s surface as a result of heavy or frequent braking.
- Refer to technical bulletins specific to the model of vehicle regarding this issue.
- Replace the brake pads, then resurface the rotors and finish them with sand paper. Refer to **BRAKE SERVICE** on page 6 for additional detail.

Single clunk noise from front suspension when applying the brakes:

- The noise is a result of the brake pads shifting in the direction of rotor rotation when the brakes are applied.
- Can be duplicated by lightly touching the brake pedal.
- If the brake pedal is pushed hard, the noise is less likely to occur.
- Make sure the brake pads and pad hardware (shims, springs, clips, etc.) are installed correctly.
- Refer to ASIST for vehicle specific brake service information.
- Refer to **BRAKE SERVICE** on page 6 for additional detail.

Multiple clunk noise and/or pedal pulsation that occurs only one time after the engine is started:

- This is a normal ABS Self Check noise. No service action is necessary.
- The vehicle’s ABS system performs a self check. On some models, this self check occurs with the first application of the brakes after the engine is started. On other models, the self check occurs the first time the vehicle reaches 5 mph after the engine is started.

Rear Brake Squeal:

- Usually due to an accumulation of brake dust and dirt between the pads/shoes and rotors or drums.
- Clean all dust and dirt from the brake pads/shoes, backing plates and related components.

WARNING: Brake dust may be hazardous if inhaled. Refer to the ESM for brake dust precautions and use approved brake cleaning equipment.

- Refer to ASIST (technical bulletins and ESM) for correct installation and lubrication of brake pads/shoes, caliper parts, and hardware.

CAUTION: Do not get grease on the brake pad/shoe friction surface.

BRAKE JUDDER

- Brake judder is caused by rotor thickness variation and/or rotor run out.

Rotor Thickness Variation: When the inner and outer surface of the rotor are not flat and not parallel, the brake pads will travel in and out as they follow the low and high spots on the rotor (see Figure 1).

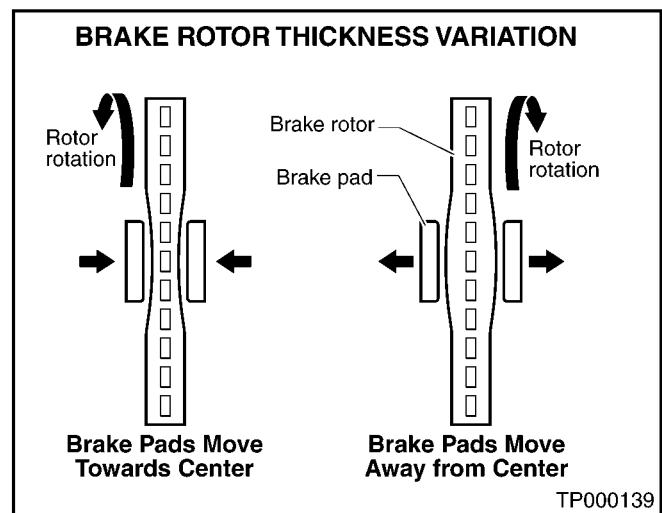

Rotor Run Out: If the brake rotor is not true to the hub center, the brake pads contact one point on each side of the rotor with each wheel rotation, even if the brakes are not applied. Over time, this point contact will cause the rotor to wear more in these areas and cause rotor thickness variation (see Figure 2).

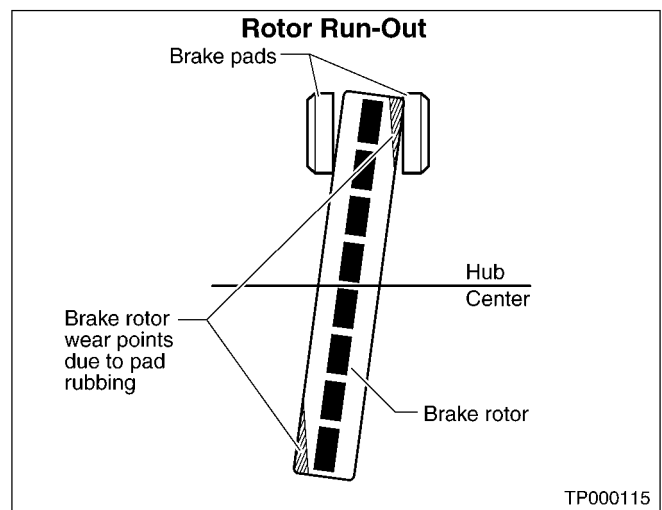

- This motion of the brake pads is transferred through the caliper pistons and is felt in the brake pedal as a pulsation. In severe cases it can also cause a back and forth oscillation in the steering wheel.

Vehicle storage:

- If the vehicle is not operated for periods of time, the area of the brake rotors not covered by the brake pads will rust.
- The friction characteristics between the rusted and un-rusted areas of the rotor braking surface will be different.
- This difference may cause brake judder at low and/or high mileage, even after the rust wears off.

Lug nut over-torque:

- Another contributor of brake judder is lug nut over-torque. This can occur if the lug nuts are over tightened, especially with an air impact wrench.

Brake judder repair

- Brake judder issues must be corrected by turning the rotors with an approved on-car brake lathe.
- Refer to page 8 for tips on using an approved on-car brake lathe.
- If the rotors are replaced, make sure to index them to the axle hub to ensure minimum runout (see **Rotor Indexing** on page 7).

PEDAL FEEL

- Some clients may say that the brake pedal feels too high or low when applying the brakes.
- This may indicate the brake system needs service or it may be the result of the client comparing the feel of the brakes in a new car with the feel of the brakes in a previous car.
- Road test the vehicle with the client. Compare brake operation to a “known good” vehicle, and determine if brake service is necessary. If so, refer to the following service items:
 - a. Inspect the brake calipers and make sure they are correctly installed and sliding freely.
 - b. Inspect the front and rear brakes and make sure the brake pads and/or shoes are properly installed.
 - c. Bleed all air from the brake system.
 - d. Make sure the brake pedal stroke and free play are adjusted correctly. Refer to the appropriate section of the ESM which covers brakes.

NOTE: Use Essential Tool J-46532 (Brake Pedal Height Tool) for brake pedal height check and adjustment. This tool is available from Tech•Mate online: www.infinititechmate.com, or by phone: 1-800-662-2001.

BRAKE SERVICE

To ensure a high quality brake service be sure to:

1. Finish rotors properly.

- This is one of the most important aspects of preventing and eliminating brake noise.
- Use an approved on-car brake lathe. Refer to page 8 for tips on using an approved on-car brake lathe.

2. Correctly install pads and shims.

IMPORTANT: Correct installation and lubrication of brake pads and all caliper parts and hardware is essential for proper brake operation and will help dampen noise-causing movement and vibrations.

- Refer to ASIST (technical bulletins and ESM) for correct installation and lubrication of brake pads, caliper parts, and hardware.

CAUTION: Do Not get grease on the brake pad friction surface.

3. Perform the following post-installation checks.

- Confirm that brake pads fit snugly in the calipers. Replace worn components as necessary.
- Test drive after repairs and burnish the new brakes. This will influence brake performance, including noise.
 - a. Drive the vehicle on a straight smooth road at about 30 mph (50 kph).
 - b. Use medium brake pedal/foot effort to bring the vehicle to a complete stop from about 30 mph (50 kph). Adjust your pedal/foot pressure so that the vehicle stopping time is 3-5 seconds.
 - c. Cool the brake system by driving at about 30 mph (50 kph) for approximately one minute without stopping.
 - d. Repeat steps a, b, and c 10 times to complete the burnishing process.

4. Follow-up to ensure client satisfaction, safety, and proper brake performance.

- Confirm the procedures described in steps 1 - 4 above have been strictly followed.

ROTOR INDEXING

When installing a new rotor, a rotor that has been surfaced off the car, or a rotor that has been removed for any reason, use the following indexing procedure to ensure the minimum amount of rotor runout.

1. Make sure the rotor is fully contacting the hub. Clean the rotor-to-hub surface if it is rusty.

NOTE: For cleaning the hub surface, specifically around the wheel studs, it is recommended to use the Wheel Hub Resurfacing Kit #J-42450-B, which can be ordered from Tech•Mate online: www.infinititechmate.com, or by phone: 1-800-662-2001.

2. Install the rotor and all lug nuts. Tighten the lug nuts to 40 ft-lbs (for this indexing process only).
3. Place a reference mark on the rotor and hub.

4. Measure rotor runout with a dial indicator.

- Measure at 10 mm (0.39 in) from the disc brake rotor edge.
- If the runout is above limit, continue with step 5.
- For more detail on rotor inspection and runout limit, refer to the appropriate ESM.

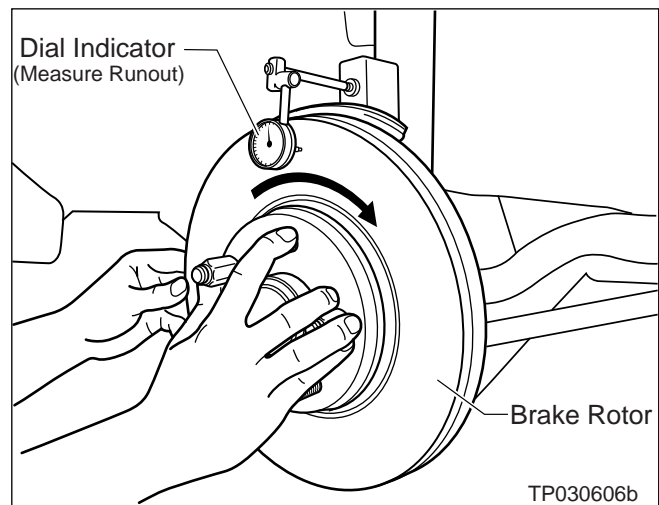

Figure 3

5. Remove the lug nuts and shift the position of the rotor one lug clockwise, then reinstall the lug nuts and torque to 40 ft-lbs (again, for this indexing process only).
 - Repeat step 4 and 5 until the rotor is positioned with the least amount of runout.
6. After you find the position with the least amount of runout, if the runout is still more than the limit you will need to turn (resurface) the new rotors using an approved on-car brake lathe.

TIPS FOR USING AN ON-CAR BRAKE LATHE

- Read and follow all instructions contained in the Technical Manual provided with your approved on-car brake lathe equipment.
- Instructional videos can be found at the manufacturer's website.
- For ProCut™ equipment, additional training is available from your local representative by calling 1-800-543-6618.
- For Hunter® equipment, visit the Hunter® website and select **Contact Hunter** in the upper right of the web page. Enter your location information to find a local representative to speak with about additional training.

A. Make sure the cutting tips are sharp, in good condition and installed "right-side" up.

- Make sure to use the appropriate cutting tips for the on-car brake lathe you are working with.
- The cutting tip "UP" side has a groove or letters.

NOTE: A tip mounted upside-down will produce a surface finish that looks like an old LP record.

- Each cutting tip has three cutting corners. Rotate or replace the tip as needed.

NOTE: You should get at least seven (7) cuts per corner. However, tip life is affected by variables such as rust or ridges. In order to determine when to rotate tips, monitor the rotor finish. If the rotor finish begins to look inconsistent or feels rough to the touch, tips should be rotated or replaced. Tips that are chipped or cracked should never be used.

B. For best accuracy, "stabilize" (firmly support) the vehicle with a jack or jack stand as shown in Figure 4.

- On some hoists, the vehicle may "wobble" a little while using the on-car brake lathe. Not good.

CAUTION: Any rocking motion (wobble) of the vehicle during the "automatic compensation" procedure will reduce the accuracy of the resurfacing.

- If wobble occurs during the rotor resurfacing process/procedure, the finished rotor runout may be more than factory specification and should be checked before using the rotor.

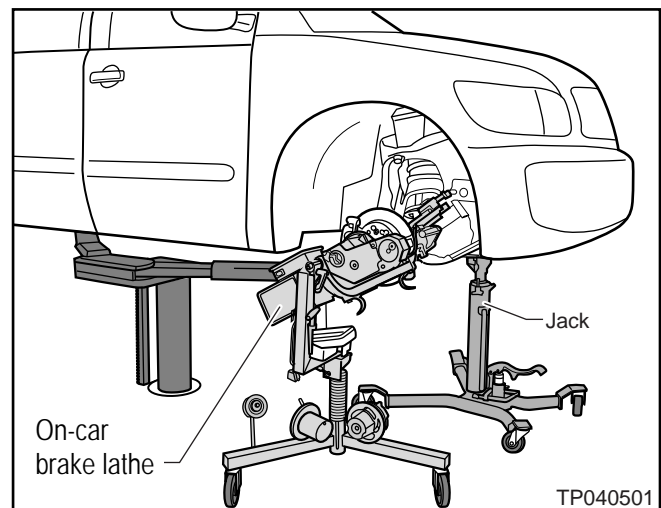

Figure 4

C. Prevent metal shavings from contacting or collecting on the ABS speed sensors.

- Remove any shavings that stick to the ABS speed sensor's magnet. It is best to clean the ABS sensor with the rotor removed.

D. After a rotor has been resurfaced with an on-car brake lathe:

- If the rotor must be removed for any reason, mark the exact location (rotor to axle hub) before removing the rotor (see Figure 5).
- The rotor must be reinstalled back to the same location.

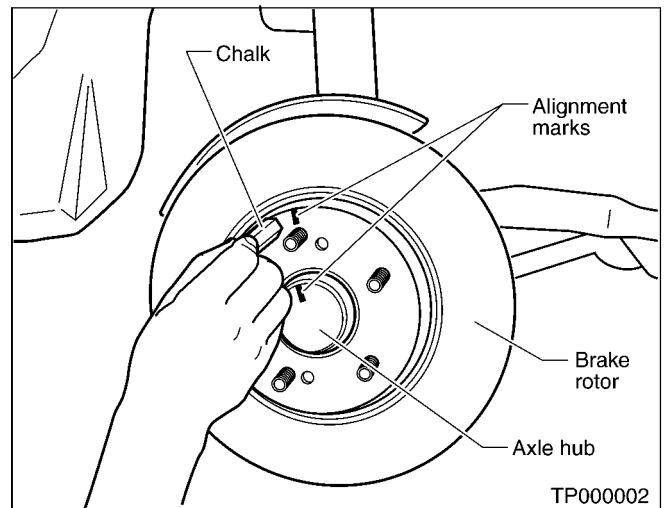

Figure 5

E. Do not tighten the wheel lug nuts with an air impact driver.

- Use a torque wrench to tighten the lug nuts to the proper torque specification.
- Uneven or high torque applied to the lug nuts may "distort" (warp) the brake rotor and hub. This may increase rotor runout and cause excessive rotor thickness variation as the rotor wears.

CLAIMS INFORMATION

Reference the current Infiniti Warranty Flat Rate Manual" and submit your claim(s) using the Operation Code (Op Code) or combination of Op Codes that best describes the operations performed.

AMENDMENT HISTORY

| PUBLISHED DATE | REFERENCE | DESCRIPTION |
|-------------------|------------|--|
| March 30, 2000 | ITB00-024 | Original bulletin published |
| June 11, 2003 | ITB00-024A | Page 6 revised |
| August 30, 2004 | ITB00-024B | Brake Judder Repair revised |
| October 23, 2006 | ITB00-024C | Publication date revised to include the latest models and model years, and Rotor Indexing updated |
| April 24, 2007 | ITB00-024D | Key value information removed |
| August 8, 2007 | ITB00-024E | Publication date revised to include the latest models and model years |
| July 23, 2013 | ITB00-024F | Publication date revised to include the latest models and model years |
| November 28, 2017 | ITB00-024G | Publication date revised to include the latest models and model years, and pages 8 and 10 updated |
| March 19, 2018 | ITB00-024H | Publication date revised to include the latest models and model years |
| May 3, 2021 | ITB00-024I | Publication date revised to include the latest models and model years, and changes made on pages 5-9 |
| January 27, 2022 | ITB00-024J | Publication date revised to include the latest models and model years |

BRAKE NOISE DIAGNOSTIC WORKSHEET

VIN: _____ Client Name: _____
W.O. # _____

Dear Client:

We are concerned about your satisfaction with your vehicle. Repairing a brake noise sometimes can be very difficult. To help us fix your vehicle right the first time, please take a moment to note the area of the vehicle where the brake noise occurs and under what conditions. You may be asked to take a test drive with a service advisor or technician to ensure we confirm the noise you are hearing.

1. WHERE DOES THE NOISE COME FROM? (Circle the area of the vehicle.)

NOTE: The illustration is for reference only, and may not reflect the actual configuration of your vehicle.

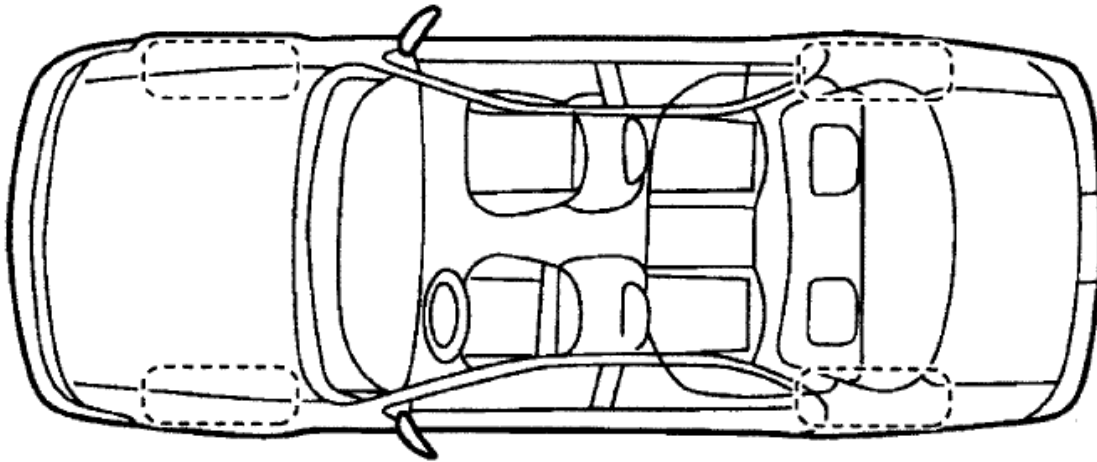

Briefly describe the location where the noise occurs:

Continue to the next page of the worksheet and indicate the conditions which are present when the noise occurs.

BRAKE NOISE DIAGNOSTIC WORKSHEET – page 2

2. WHEN DOES IT OCCUR? (Please circle the conditions that apply.)

a. Vehicle condition:

- Throughout driving
- Vehicle at stop

b. Vehicle speed:

- Very low (under 3 kph, 3 mph)
- Low (5-20 kph, 3-13 mph)
- Mid (20-60 kph, 13-37 mph)
- High (over 60 kph, 37 mph)

c. Brake pedal condition:

- During applying the brake
- When not applying the brake

c-1. WHEN IT OCCURS DURING APPLYING THE BRAKE:

- Depressing lightly
- Depressing slowly
- Depressing further after once depressed
- When releasing the brake pedal gradually
- Noise stops when parking brake is applied
- Other: _____
- Depressing strongly
- Depressing rapidly
- When brake pedal is released
- When brake pedal is released rapidly

c-2. WHEN IT OCCURS NOT APPLYING THE BRAKE:

- Noise stops when brake pedal is depressed
- Other: _____

BRAKE NOISE DIAGNOSTIC WORKSHEET – page 3

d. Environment:

- Driving in the rain or snow, or after the day it rained or snowed
- After washing the vehicle
- After leaving the vehicle for a while
(When engine was started first time in the morning, or starting the engine after shopping.)
- After driving the vehicle for a while
- Other: _____

e. Driving condition:

- While driving on flat road
- While driving on rough road or after driving on rough road
- When driving over a speed bump or after driving over the speed bump
- While driving forward
- While driving backwards (reverse)
- Repeatedly driving forward and backwards (reverse)
- When turning right or left
- Just before stopping
- Other: _____

3. WHAT IS THE CONTINUOUSNESS OF THE NOISE?

- Noise occurs when brake is applied and noise continues until vehicle stops.
- Noise occurs only at the moment when brake pedal is depressed.
- Noise occurs when vehicle starts to reduce speed after depressing the brake pedal and continues until just before stopping.
- Noise occurs when depressing/releasing the brake pedal.
- Noise stops when releasing the brake pedal.
- Noise stops after depressing the brake pedal for couple of times.
- Noise recurs after leaving the vehicle for several hours.
- Other: _____