

Hood Latch Assembly, Retrofit AN

FSB 821-027 Hood Latch Assembly, Retrofit

(January 2022)

On certain Mack Anthem model trucks built from January 29th, 2018 to present customers may experience difficulty opening the hood, particularly in cold weather climates.

If this condition exists, follow the procedures outlined in this Field Service Bulletin (FSB).

Order parts listed in required parts section and repair vehicle per standard instructions in Impact.

Remove the hood release latch/cable assemblies and install the rubber hood latch straps as per instructions outlined in this Field Service Bulletin (FSB).

Required Parts

Part Number	Description	Quantity
23961452	Hood Latch Strap, Replacement Kit	1

Repair Procedure

- 1 Park the vehicle on a flat and level surface.
- 2 Apply the parking brake.
- 3 Place the gear lever in neutral.
- 4 Install the wheel chocks.

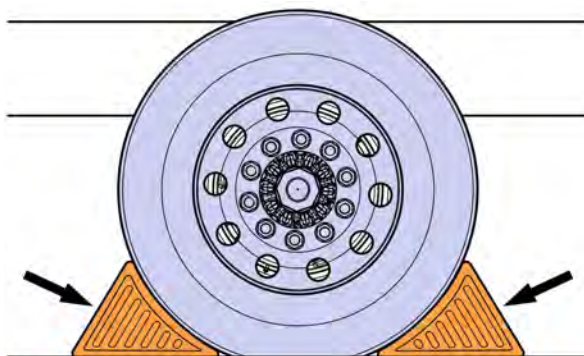

W7086748

- 5 Disconnect the cable from the negative terminal.

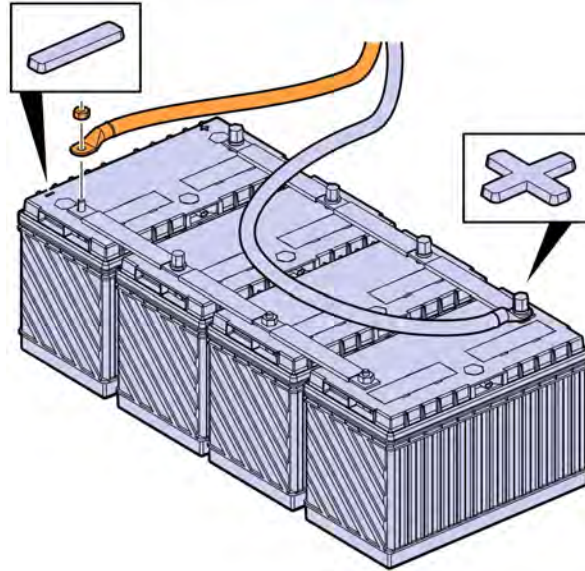

C3172182

- 6 Refer IMPACT document ID: **8211-05-02-02 Hood, adjust** for hood adjustment procedure.
Note: Make sure that hood is adjusted before proceeding further.

- 7 Remove the screws.

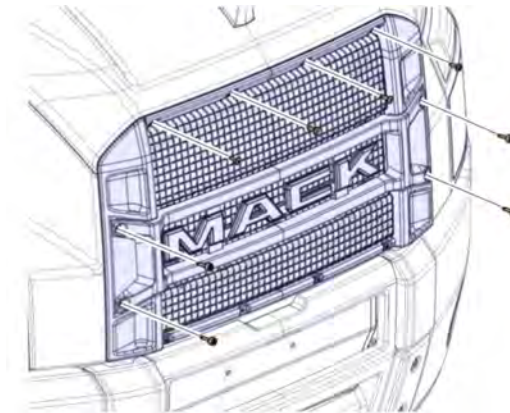

C8172266

8 Remove the grille.

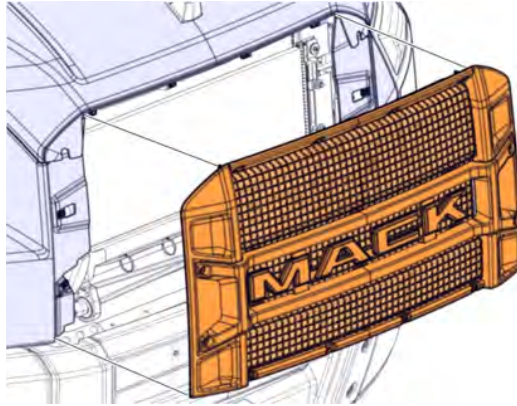

C8172267

9 Unlatch and raise the hood.

10 Remove the screws and washers.

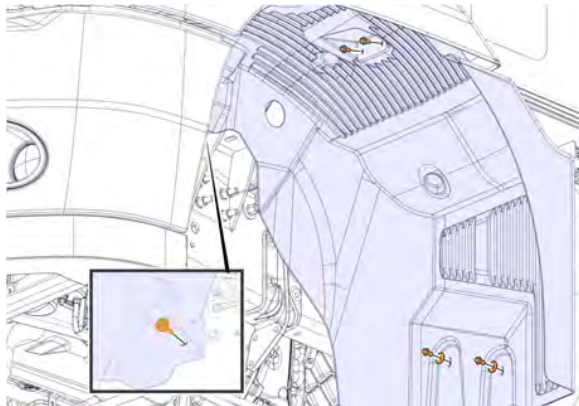

C8172481

11 Remove the splash shield.

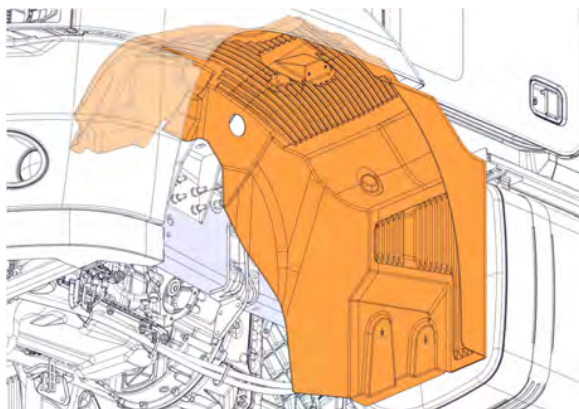

C8172482

12 Remove the splash shield on the other side in the same way.

13 Remove all cable ties from both sides.

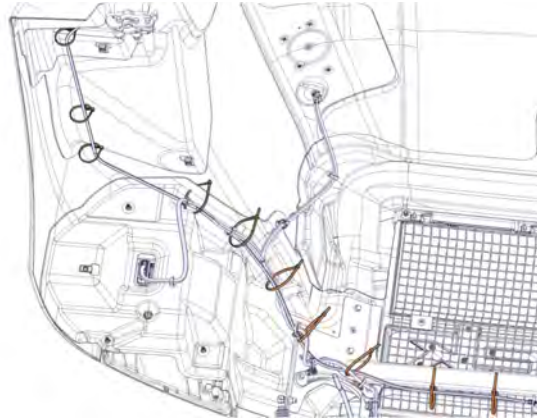

C8172138

14 Loosen the adjustment nuts.

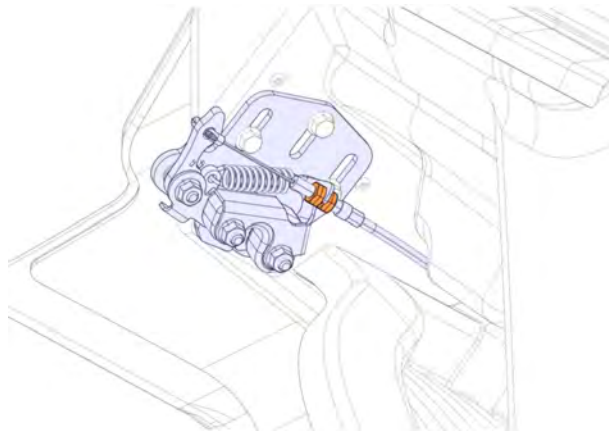

C8172131

15 Remove the cable.

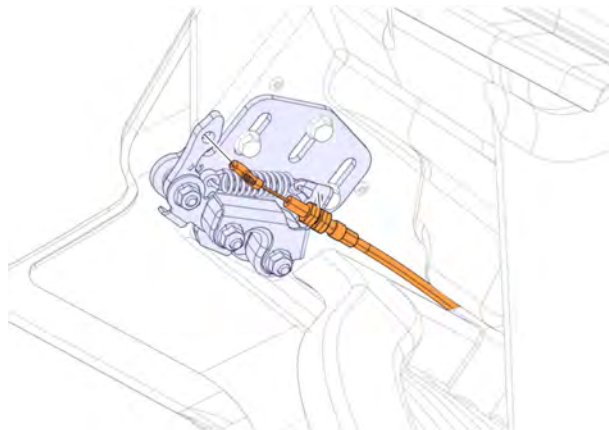

C8172132

- 16 Remove the cable tie.
- 17 Remove the clip.
- 18 Remove the cable.

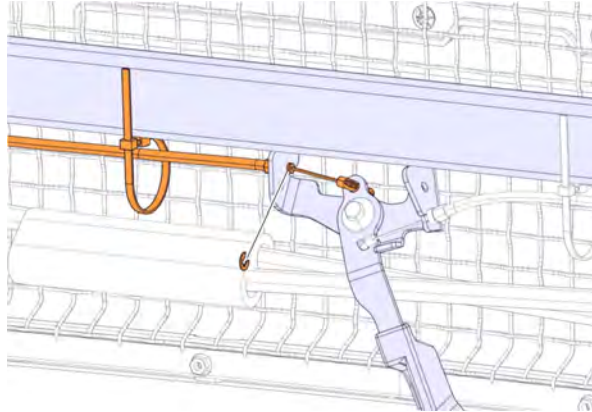

C8172133

- 19 Remove the cable on the other side in the same way.
- 20 Remove the screw.
- 21 Remove the lever.

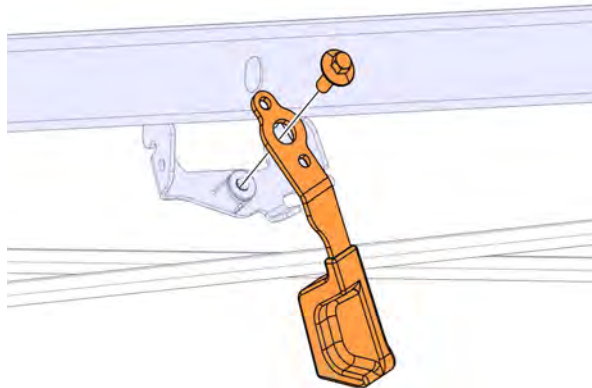

C8172134

22 Remove the screws.

23 Remove the latch.

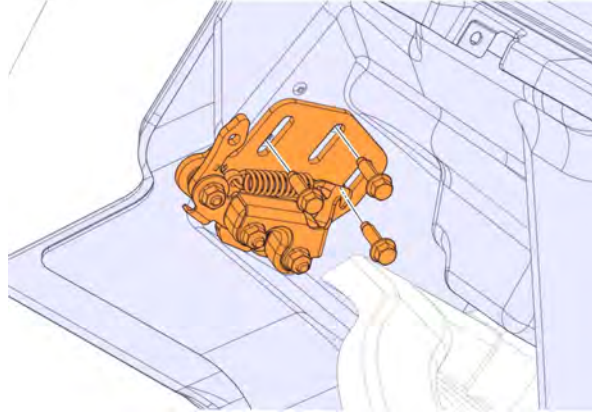

C8172135

24 Remove the latch on the other side in the same way.

25 Remove interior right and left side cover.

Note: Panels covers can be removed without removing any other panels the door seal just needs to be pulled out of the way.



C8172269



C8172270

26 Remove the screws and spacers.

27 Remove the bracket.

Note: 2 of the 5 screws and spacers will need to be reused.

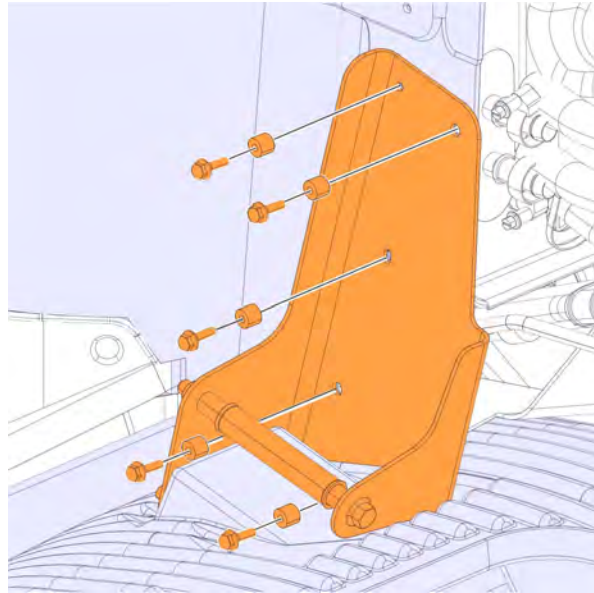

C8172137

28 Remove the bracket on the other side in the same way.

29 Plug the lower hole in the BIW by installing a screw.

Note: M6 Flange Head Screw Part No:984726

30 Torque tighten the screws 12 ± 2 Nm.

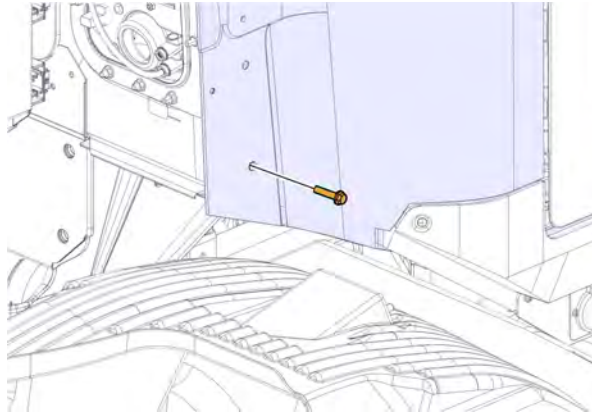

C8172149

31 Position the BIW bracket.

Note: Use a new part.

32 Install the screws.

Note: Reinstall 2 of the 5 screws and spacers removed from truck (per side)

33 Torque tighten the screws 12 ± 2 Nm.

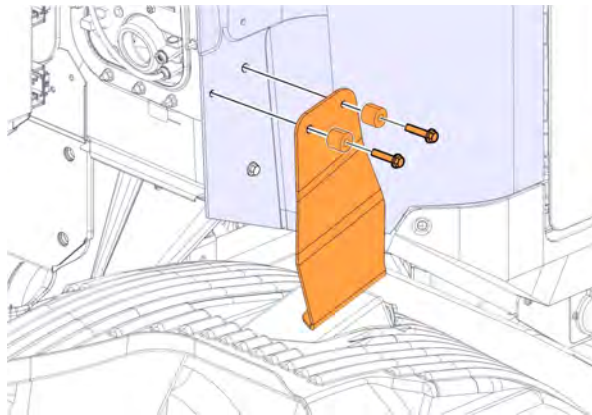

C8172150

34 Position the bow-tie bracket

Note: Use a new part.

35 Install the screws.

M6 Flange Head Screw Part No:984726

Note: Reinstall screws removed from truck.

36 Torque tighten the screws 12 ± 2 Nm.

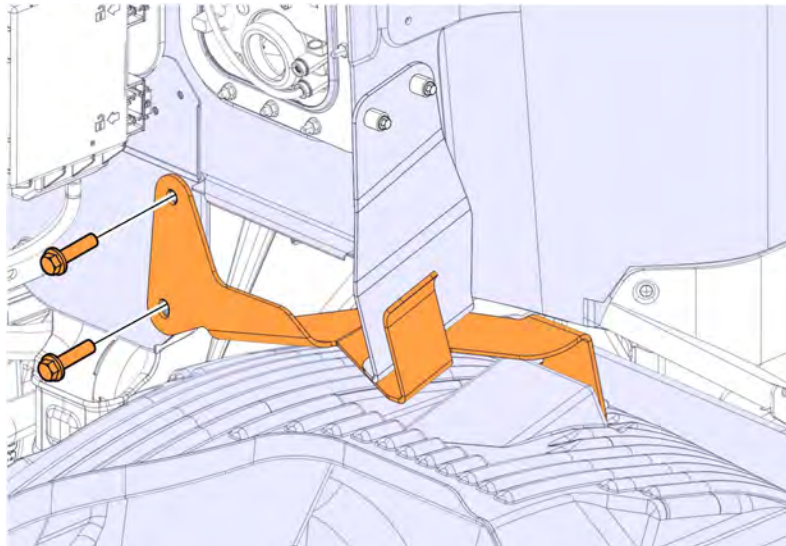

C8172151

37 Install the screws.

Note: M6 Flange Head Screw Part No:984726

38 Torque tighten the screws 12 ± 2 Nm.

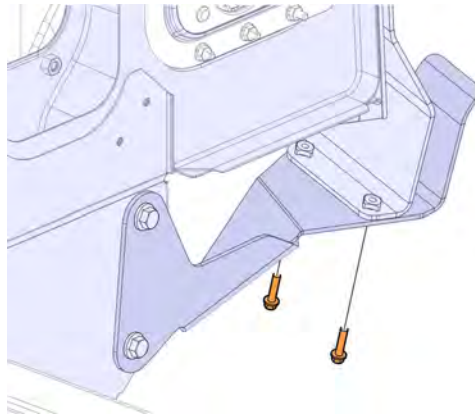

C8172152



C8172273

39 Install the bracket on the other side in the same way.

40 Install hood alignment foot to both sides of the hood.

Note: Use M8 flange screw (994447) and washers (990299)

41 Torque tighten the screws 24 ± 4 Nm.

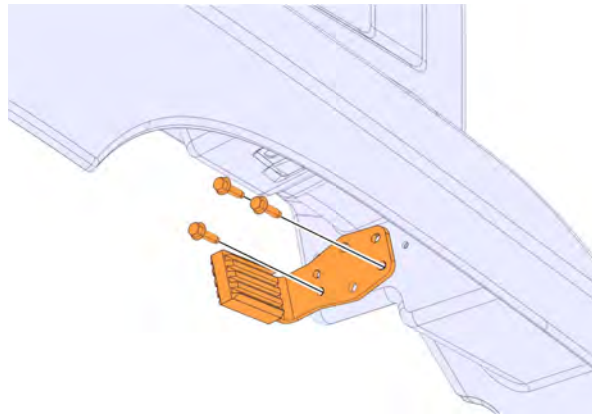

C8172172



C8172271

42 Ensure the gap between the BIW bracket and bow-tie bracket is sufficient for the guide to slide.

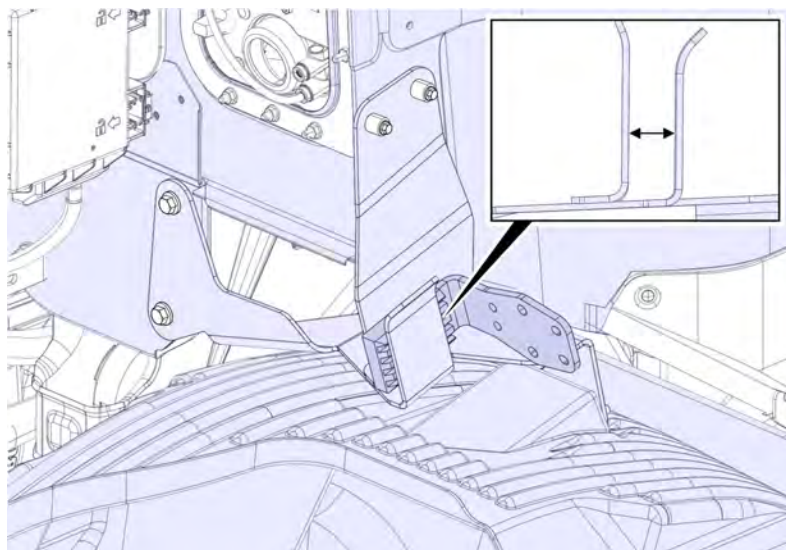

C8172154

43 Mark the holes on A pillar.

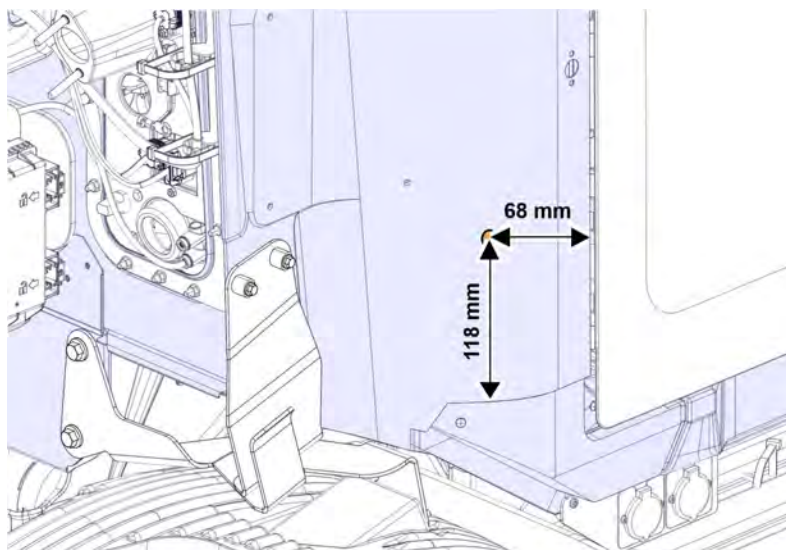

C8172766

44 Drill 15mm holes on the A pillar.

Note: Center punch the hole before drilling to avoid drill bit walking.

Note: Once the first hole is drilled, the nut plate can be used as a template.

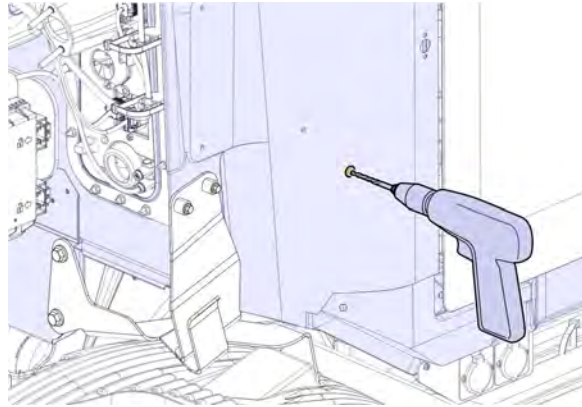

C8172159



C8172160

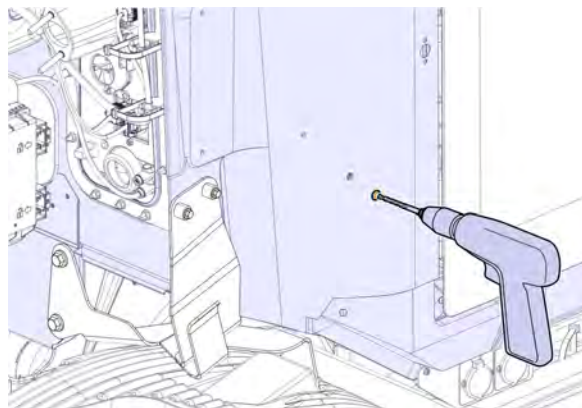

C8172161

45 Use adhesive on the nut plate to secure location.

Note: Use locally sourced two parts **Epoxy gel** .

Note: Adhesive is only for ease of future disassembly/serviceability.

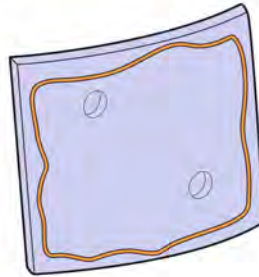

C8172162

46 Install the nut plate in BIW



C8173040

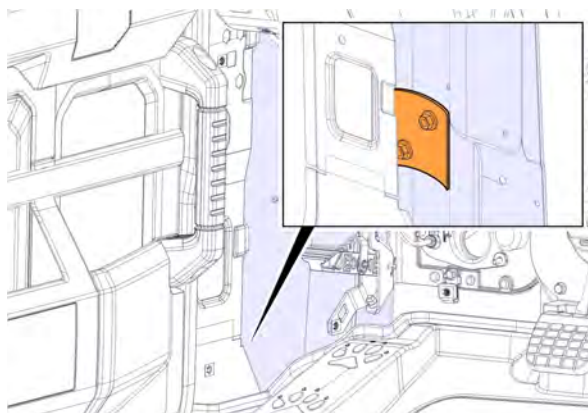

C8172163

47 Install the strap keeper to BIW.

Note: Both pieces are side-specific, ensure they are not mixed up.

Note: Use M6 six point socket screws (AKA Torx head) Part No:994787.

48 Torque tighten the fasteners to 10 ± 1.5 Nm.

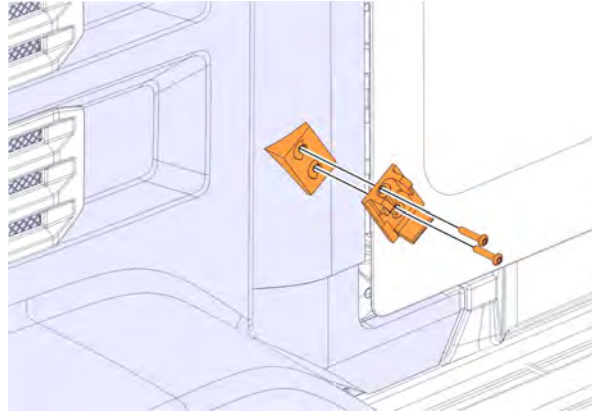

C8172164

49 Install the strap keeper to BIW on the other side in the same way.

50 Trim 50mm of hood fender material away to provide adequate clearance during hood swing.



C8172165

51 Adjust the hood.

Note: Ensure the hood is fully closed when checking.

Note: Add or remove shims from tower brackets so that the body lines between hood and BIW line up.

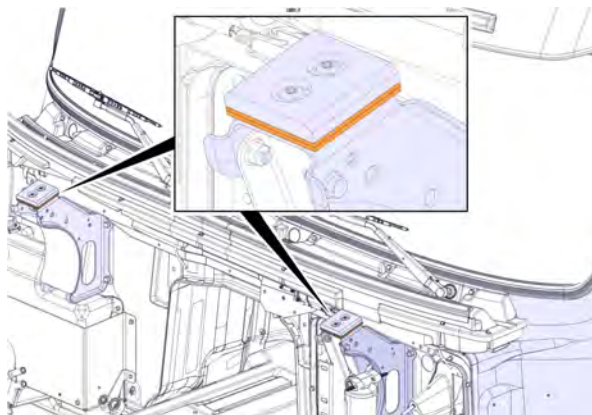

C8172167

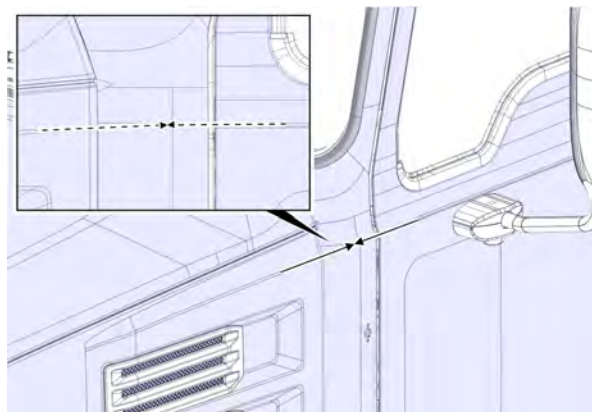

C8172166

52 Drill holes in the hood.

Note: Center punch the hole before drilling to avoid drill bit walking.

Note: Hood must be in the finally adjusted and fully closed position.

53 Measuring from the strap mount holes on the BIW, mark and drill 10mm holes through hood for the strap to mount to

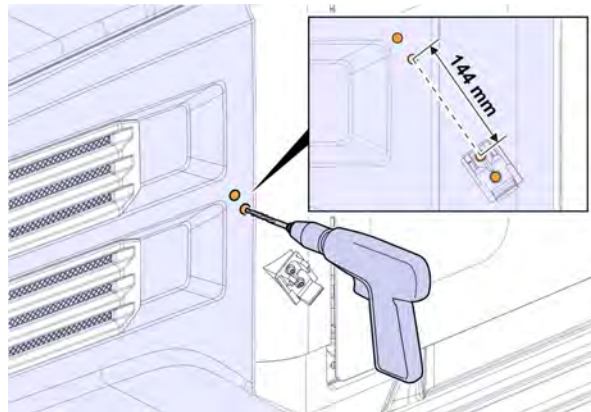

C8172168

54 Install the hood nut plate.

Note: Hood reinforcement may need to be trimmed to allow nut plate to be installed.

Note: Only a minimum amount of material should be removed to allow the nut plate to be installed.

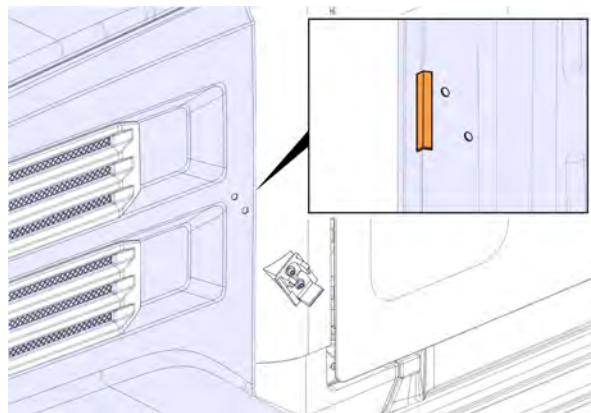

C8172169

55 Torque tighten the fasteners to 10 ± 1.5 Nm.

Note: Use M6 six point socket screws (AKA Torx head) Part No: 994787.

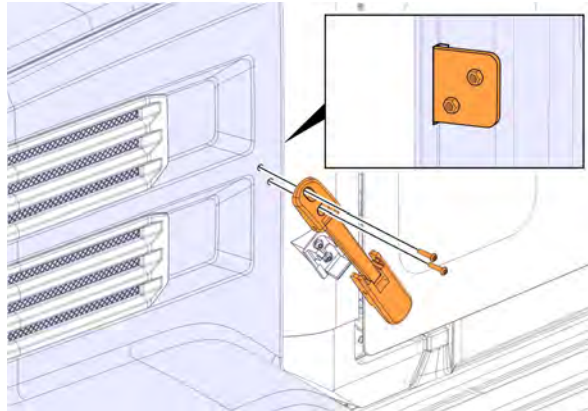

C8172170

56 Install spacers to tower bracket.

Note: Two spacers should be installed on **LH tower bracket only**.

Note: Holes already exist on tower bracket

Note: Use M12 nuts and bolts

57 Torque tighten the fasteners to 85 ± 15 Nm.

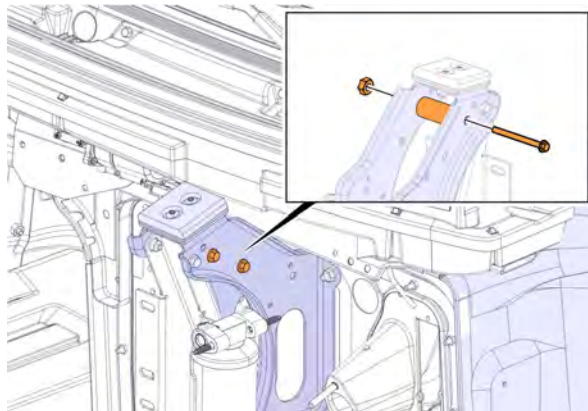

C8172171

58 Check for correct functioning of the hood.

59 Install the splash shield.

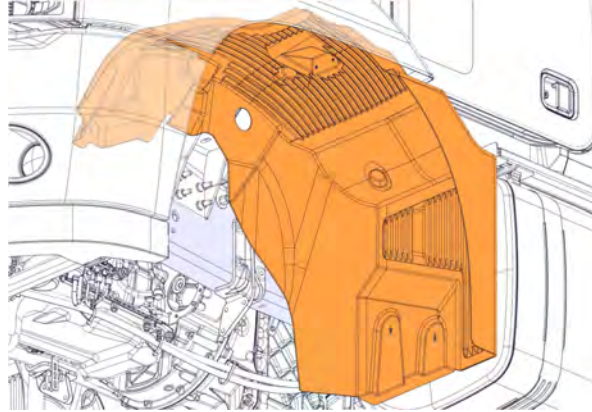

C8172482

60 Install the screws and washers.

61 Torque tighten the screws to 24 ± 4 Nm.



C8172481

62 Install the splash shield on the other side in the same way.

63 Install the grille.

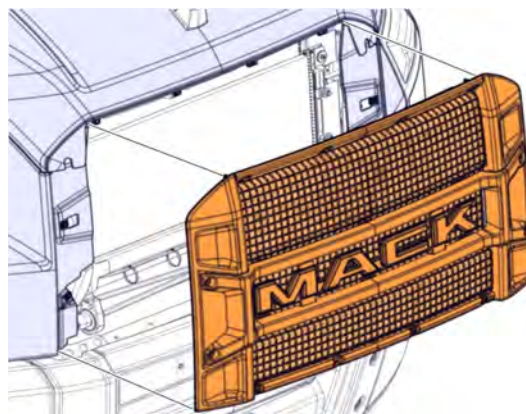

C8172267

64 Install the screws.

65 Torque tighten the fasteners to 10 ± 1.5 Nm.

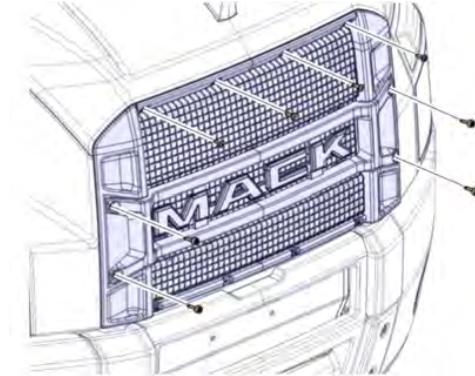

C8172266

66 Connect the cable to the negative terminal.

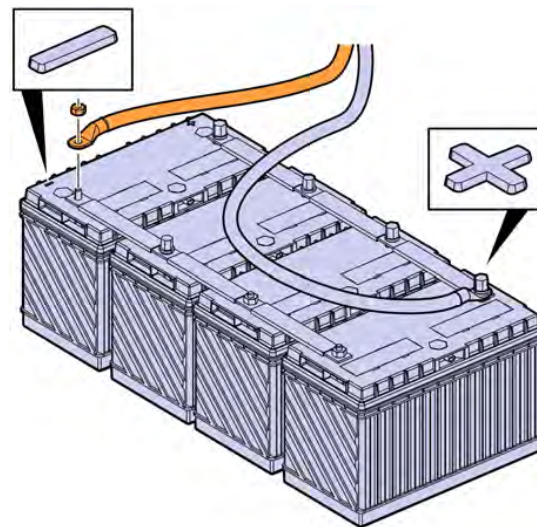

C3172182

67 Remove the wheel chocks.

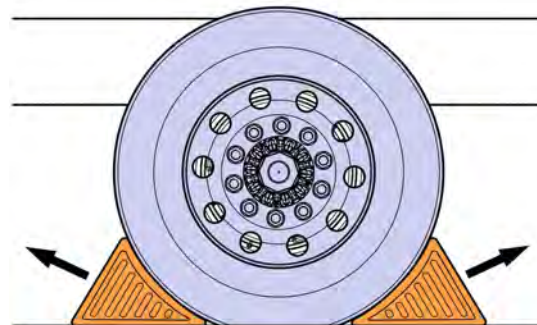

W7086759

Reimbursement

This repair may be eligible for reimbursement if a product failure was experienced within time and mileage limits of the applicable Warranty coverage. Reimbursement is obtained via the normal claim handling process.	UCHP Reimbursement
Claim Type (used only when uploading from the Dealer Bus. Sys.)	
Labor Code	
Primary Labor Code Hood Latch Assembly, Retrofitment	8210-03-09-01 (3.3 hrs)
Causal Part	82796225