



Mack Chassis - Conventional Models (Anthem, Pinnacle, Granite) - Service Brakes Fail To Release; Brakes Sticking After Brake Pedal Is Released - Built Between 1 November 2018 And 31 March 2019



> **Internal Content**

If a unit is brought to the dealer with this complaint:

1. Firmly pull the brake pedal forward to establish if the plunger is hanging up or binding.
2. Verify the plunger is moving in a smooth fashion.

If the plunger is found to be hanging up or binding:

1. Replace the plunger.
2. File a case with Reliability and send the failed parts to the address below.

Michael Moriarty

Volvo Trucks Uptime Center

8003 Piedmont Triad Parkway

Greensboro, NC 27409



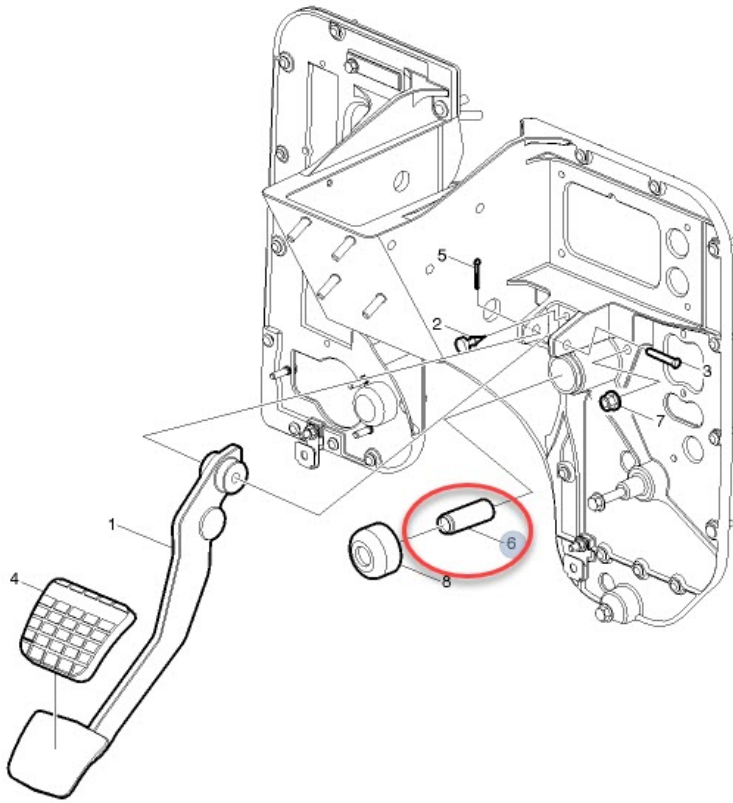

NOTE: Parts stamped with the “I” as in the picture below, were manufactured with a refurbished tool beginning 03/11/2019. These parts should be to spec and cause no issues.



Tags

[k82206202](#)

[mack](#)

 Live UI

Related links and attachments

No links or attachments available



Feedback

[Give feedback](#)

to help improve the content of this article