



STAR ONLINE PUBLICATION



Case Number: S2121000003

Release Date: 3/04/2021

Symptom/Vehicle Issue: Transfer Case Gear Motor/Actuator Installation Guidelines.

NOTE: Do not attempt to rotate the Transfer case gear motor/actuator to align with transfer case shaft prior to installations. This will lead to potential damage of the unit, and or shift errors/DTCs

Discussion: When installing a replacement transfer case gear motor/actuator assembly, it is important to ensure the transfer case shift fork is in the proper position. All transfer case gear motors/actuators are shipped in the AWD/2WD position See (**Figure 1**). Prior to installing the new gear motor/actuator, manually place the transfer case into the AWD/2WD position.

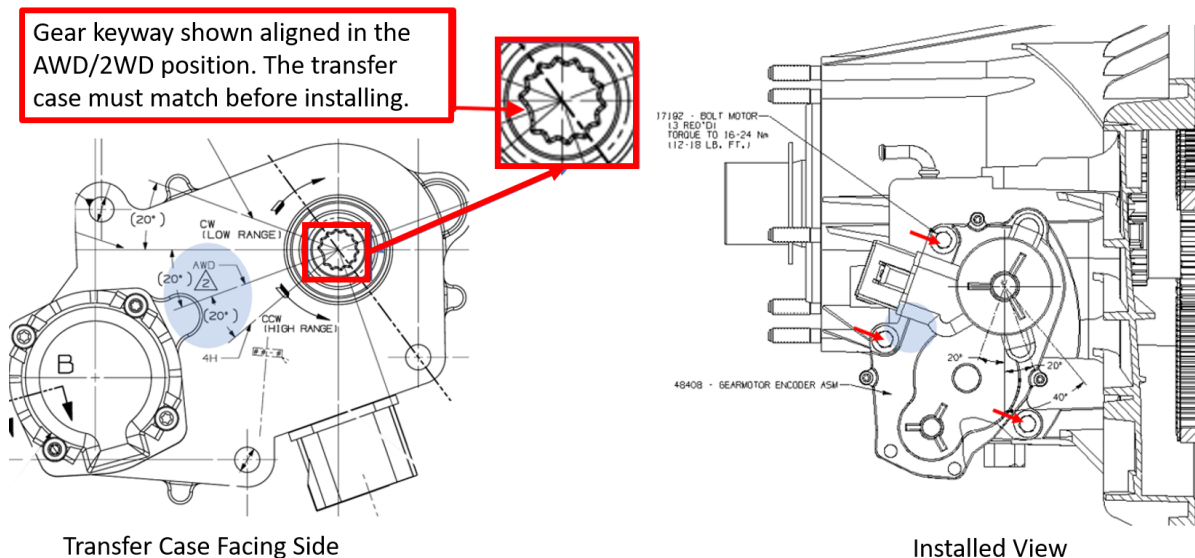

Figure 1.

This document does not authorize warranty repairs. This communication documents a record of past experiences. STAR Online does not provide any conclusions about what is wrong with the vehicle. Rather, it captures all previous cases known that appear to be similar or related to the vehicle symptom / condition. You are the expert, and you are responsible for deciding on the appropriate course of action.

Contact STAR Center, or your Technical Assistance Center Via TechCONNECT or eCONTACT ticket if no solution is found