

2016 Mazda3 INTERMITTENT NO CRANK / NO START

Some customers may complain about an intermittent no crank/no start. This may be caused by a poor instrument panel wiring harness connection C-12. The accessory mirror with compass T-harness connector at drivers side A-pillar may not be seated (locked).

Properly secure the instrument panel wiring harness, upper and lower C-12 connectors to resolve customer complaint.

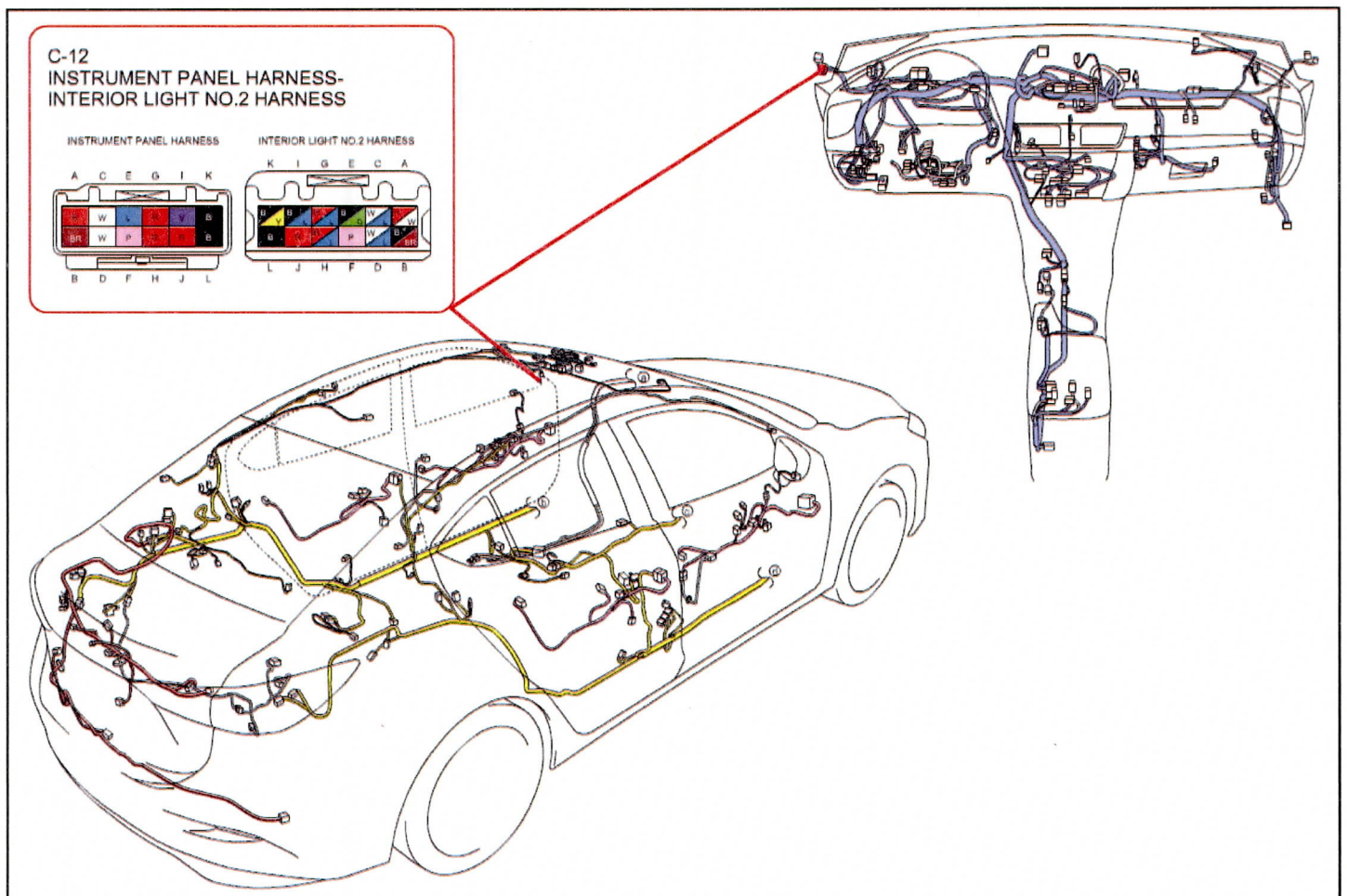
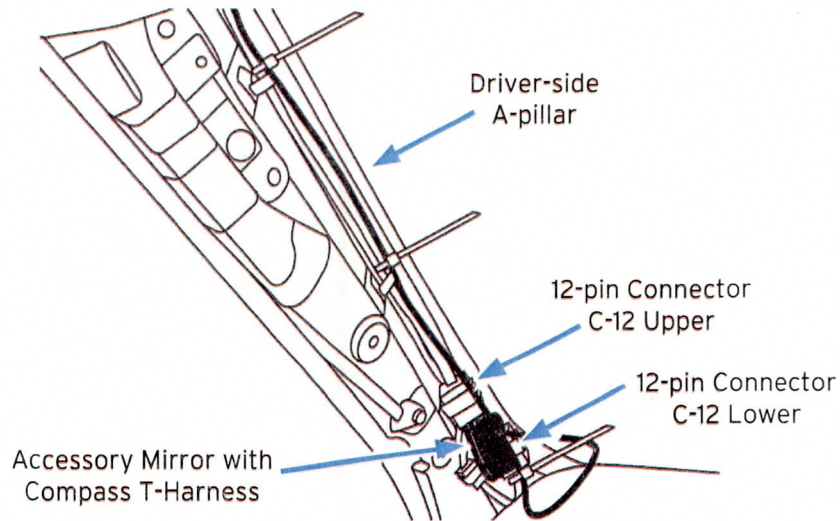

An editorial board comprised of MNAO service staff members generates, collects, and verifies information for this publication. © 2015 Mazda Motor of America, Inc.

To contribute repair tip ideas, send an e-mail to mtips@mazdausa.com or fax to (949) 442-6599. If we select your repair tip, you will receive 10,000 Reward Performance by Mazda (RPM) points for your efforts. All contributions become property of MNAO, which assumes permission to publish them without further consideration.