



Service Bulletin

Bulletin No.: 17-NA-221

Date: December, 2021

TECHNICAL

Subject: Poor Engine Performance in Extremely Cold Weather Conditions for LE2 Engines, Charge Air Cooler Icing - Malfunction Indicator Lamp (MIL) Illuminated, DTC P0299, P0234, P0236, P2227, P00C7 Set

Brand:	Model:	Model Year:		VIN:		Engine:	Transmission:
		from	to	from	to		
Buick	Encore	2016	2019	—	—	1.4L (LE2)	—
		2021	2022				
Chevrolet	Trax	2021	2022				

Involved Region or Country	North America
Condition	<p>Some customers may comment that when driving short distances and/or slow speed driving cycles, their vehicle experiences one or several of the following conditions within the first 10 to 15 minutes of vehicle operation in extremely cold weather conditions (-18°C or less / 0°F or less):</p> <ul style="list-style-type: none"> • Loss of power • Smoke out the tail pipe • Hesitation on acceleration • Stalling condition • Burning oil odor possibly caused by oil leak • May also notice a Malfunction Indicator Lamp illuminated • After driving for a period of time, the driveability issues seem to diminish. <p>This condition may also cause an increase in crankcase pressure, creating oil leaks at seals and gaskets.</p> <p>Technicians may find one or more of the following DTCs set:</p> <ul style="list-style-type: none"> • P0234 • P0236 • P0299 • P2227 • P00C7
Cause	This condition may be caused by ice accumulation in the charge air cooler (CAC), restricting air flow to the throttle body.

<p>Correction</p>	<p>If any of the above conditions are present, allow time for possible ice build up in the CAC to melt by allowing the vehicle to thaw in a warm climate.</p> <p>If any of the following conditions are validated to be caused by freezing/icing, replace the CAC.</p> <p>If not previously performed, an oil change may be necessary to remove any moisture from the engine. Prior to the oil change, run the engine at idle for an extended period of time to melt any ice in the engine.</p> <p>If there is a check engine light with a P0234 or P0299 DTC during cold weather driving, refer to Turbocharger Wastegate Regulator Solenoid Valve Inspection below.</p> <ul style="list-style-type: none"> – Frozen oil/water condensate contaminant in the Turbocharger Wastegate Regulator Solenoid Valve (TCV) is often concurrent with vehicle operation conditions that cause CAC freezing. <p>Important: The new ECM calibration is only applicable for MY 2018, 2019 and 2021 vehicles with LE2 engines. In MY 2020 there was no LE2 engine.</p> <p>Note: The Engine Control Module calibration should be updated. The new calibration will enable a revised transmission shift pattern during cold weather operation, which does not use overdrive as frequently. As a result, <i>some customers</i> may notice elevated engine RPMs during highway operation. This operating mode will reduce the potential for ice to build up inside the charge air cooler, and the potential for setting P0299 or P0234 diagnostic codes.</p> <p>The customer must be <i>informed</i> by dealership personnel by explaining the new engine control module calibration and its <i>effects</i> on transmission shift patterns at highway speeds during cold weather to avoid a customer return to the dealership after the programming is completed.</p>
--------------------------	---

Important: Allow time for the vehicle to thaw in a warm environment to avoid damaging or breaking parts that may be required to be re-installed.

Turbocharger Wastegate Regulator Solenoid Valve Inspection

Important: For additional information on Oil/Moisture Condensate Freezing Up in the Turbocharger Wastegate Regulator Solenoid Valve, refer to the latest version of PIP5812.

Grille Winter Cover Installation

Warning: Remove grille cover during temperatures above 32°F/ 0°C to prevent engine and transmission overheating. Remove grille cover before towing a trailer of any size. Failure to do so will decrease transmission cooling efficiency and possibly cause damage to the drivetrain.

Note: The cover may appear to be undersized. The vinyl used may stretch during installation to ensure a tight fit. It is highly recommended that the cover be installed in a warm shop environment.

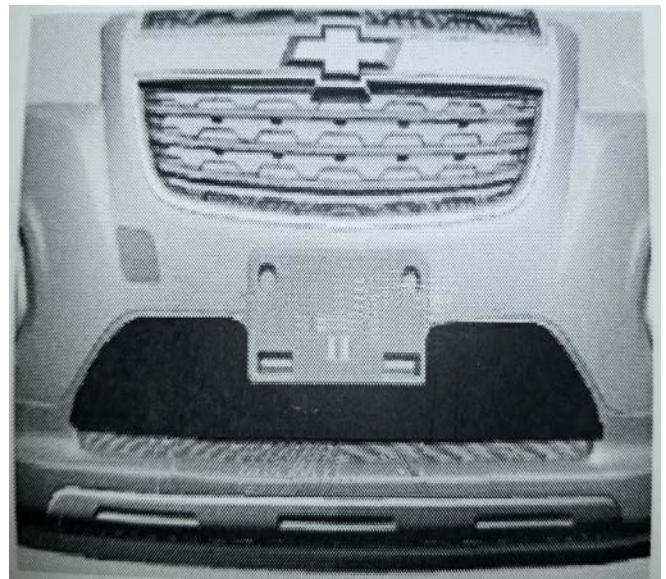

5197596

1. Using care, orientate the fascia winter cover to the bumper fascia.

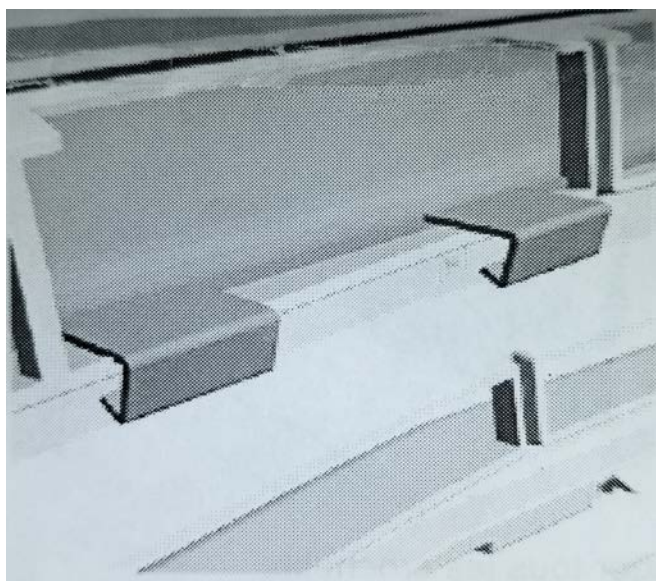

5193266

2. Attach the cover to the fascia by pushing the hooks through the grille openings.
3. Validate that all the hooks are engaged and the cover is a tight fit.

Turbocharger Air Pressure Sensor Inspection

Important: Only perform steps 1-5 if DTC P0299 is set.

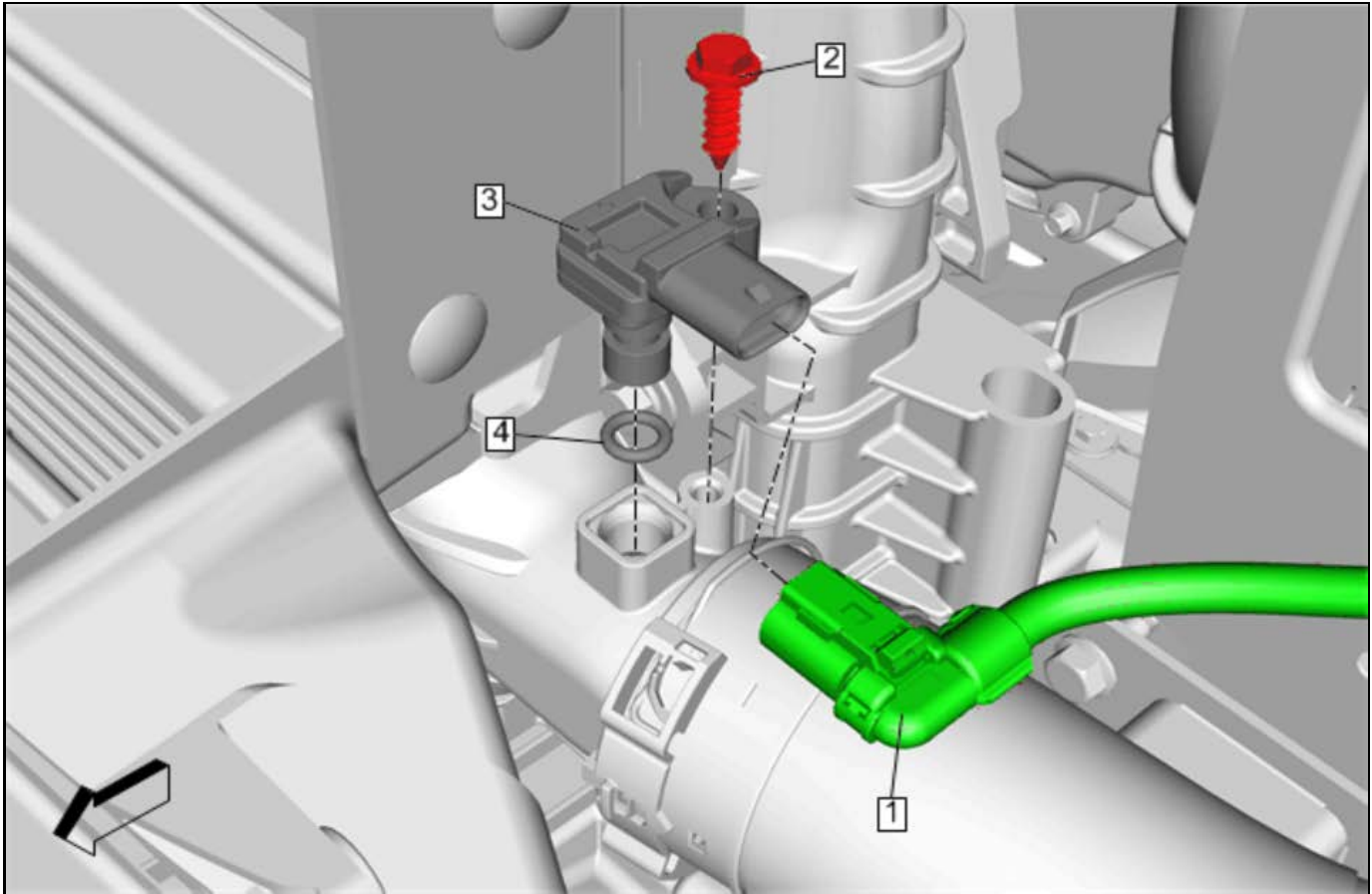

4108751

1. Remove the turbocharger Air Pressure sensor (3). Refer to *Turbocharger Air Pressure Sensor Replacement* in SI.

Important: Due to the sensitivity of the sensor, **Do Not** use any chemical cleaners including water and **Do Not** use compressed air to remove contaminants.

2. Inspect the sensor for any contaminants.



4910683

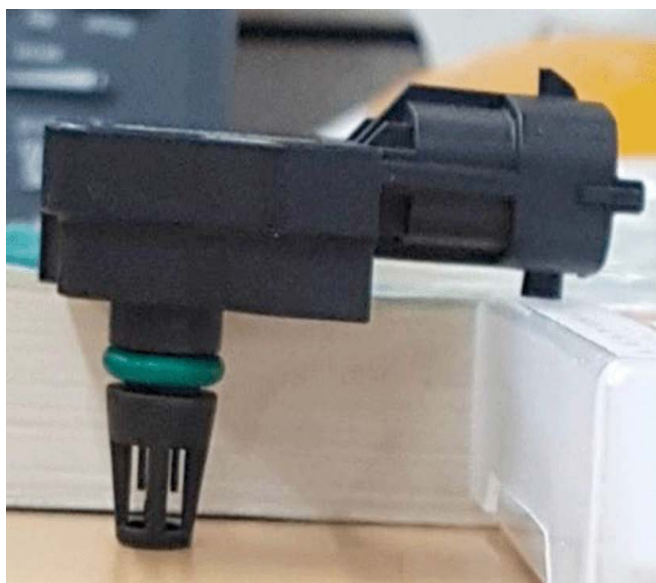

5020216

3. Allow time for any ice build-up to melt by placing the sensor port down.
4. Clean the sensor with a clean towel.
5. Install the sensor.

Service Procedure

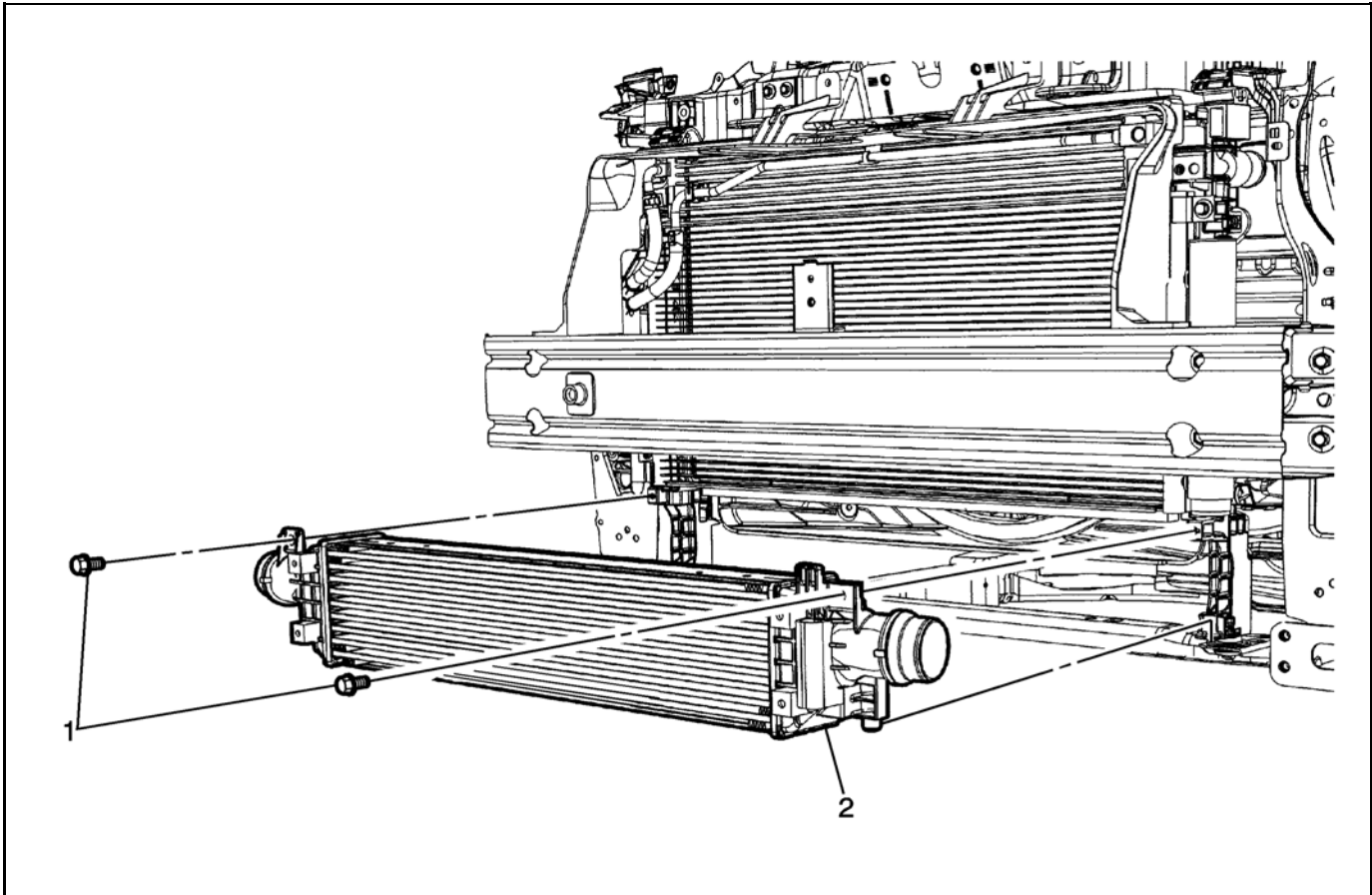

2851444

1. Install the CAC (2). Refer to *Charge Air Cooler Replacement* in SI.

Important: Do Not perform an oil change if the oil change was recently done.

- If the oil change was recently done and no signs of moisture have been confirmed, Do Not proceed with procedure.
- If the oil change was not previously done or moisture has been found in the oil, proceed with procedure.

2. If required, perform an oil change. Refer to *Engine Oil and Oil Filter Replacement* in SI.

Engine Control Module Programming

Important: Updated Engine Control Module calibration: The updated calibration will enable a revised transmission shift pattern during cold weather operation, which does not use overdrive as frequently. As a result, the customer may notice elevated engine RPMs during highway operation. This operating mode will reduce the potential for ice to build up inside the charge air cooler, and the potential for setting P0299 or P0234 diagnostic codes.

Caution: Before downloading the update files, be sure the computer is connected to the internet through a network cable (hardwired). DO NOT DOWNLOAD or

install the files wirelessly. If there is an interruption during programming, programming failure or control module damage may occur.

- Ensure the programming tool is equipped with the latest software and is securely connected to the data link connector. If there is an interruption during programming, programming failure or control module damage may occur.
- Stable battery voltage is critical during programming. Any fluctuation, spiking, over voltage or loss of voltage will interrupt programming. Install a GM Authorized Programming Support Tool to maintain system voltage. Refer to www.gmdesolutions.com for further information. If not available, connect a fully charged 12V jumper or booster pack disconnected from the AC voltage supply. DO NOT connect a battery charger.
- Follow the on-screen prompts regarding ignition power mode, but ensure that anything that drains excessive power (exterior lights, HVAC blower motor, etc) is off.
- Please verify that the radio time and date are set correctly before inserting USB drive into vehicle for programming, otherwise an error will result.
- Clear DTCs after programming is complete. Clearing powertrain DTCs will set the Inspection/Maintenance (I/M) system status indicators to NO.

Important: The service technician always needs to verify that the VIN displayed in the TLC left side drop down menu and the top center window match the VIN plate of the vehicle to be programmed prior to using Service Programming System 2 (SPS2) for programming or reprogramming a module.

- For the TLC application, service technicians need to always ensure that the power mode (ignition) is “ON” before reading the VIN from the vehicle’s VIN master module and that they do not select a VIN that is already in the TLC application memory from a previous vehicle.
- If the VIN that shows up in the TLC top center window after correctly reading the VIN from the vehicle does not match the VIN plate of the vehicle, manually type in the VIN characters from the vehicle VIN plate into the TLC top center window and use these for programming or reprogramming the subject module with the correct vehicle VIN and software and/or calibrations.
- The Engine Control Module (ECM) is the master module (for VIP vehicles) that TLC reads to determine the VIN of the vehicle. If the VIN read from the vehicle by TLC does not match the VIN plate of the vehicle, the ECM also needs to be reprogrammed with the correct VIN, software and calibrations that match the vehicle’s VIN plate.
- The Body Control Module (BCM) is the master module (for GEM vehicles) that TLC reads to determine the VIN of the vehicle. If the VIN read from the vehicle by TLC does not match the VIN plate of the vehicle, the BCM also needs to be reprogrammed with the correct VIN, software and calibrations that match the vehicle’s VIN plate.

Caution: Be sure the VIN selected in the drop down menu (1) is the same as the vehicle connected (2) before beginning programming.

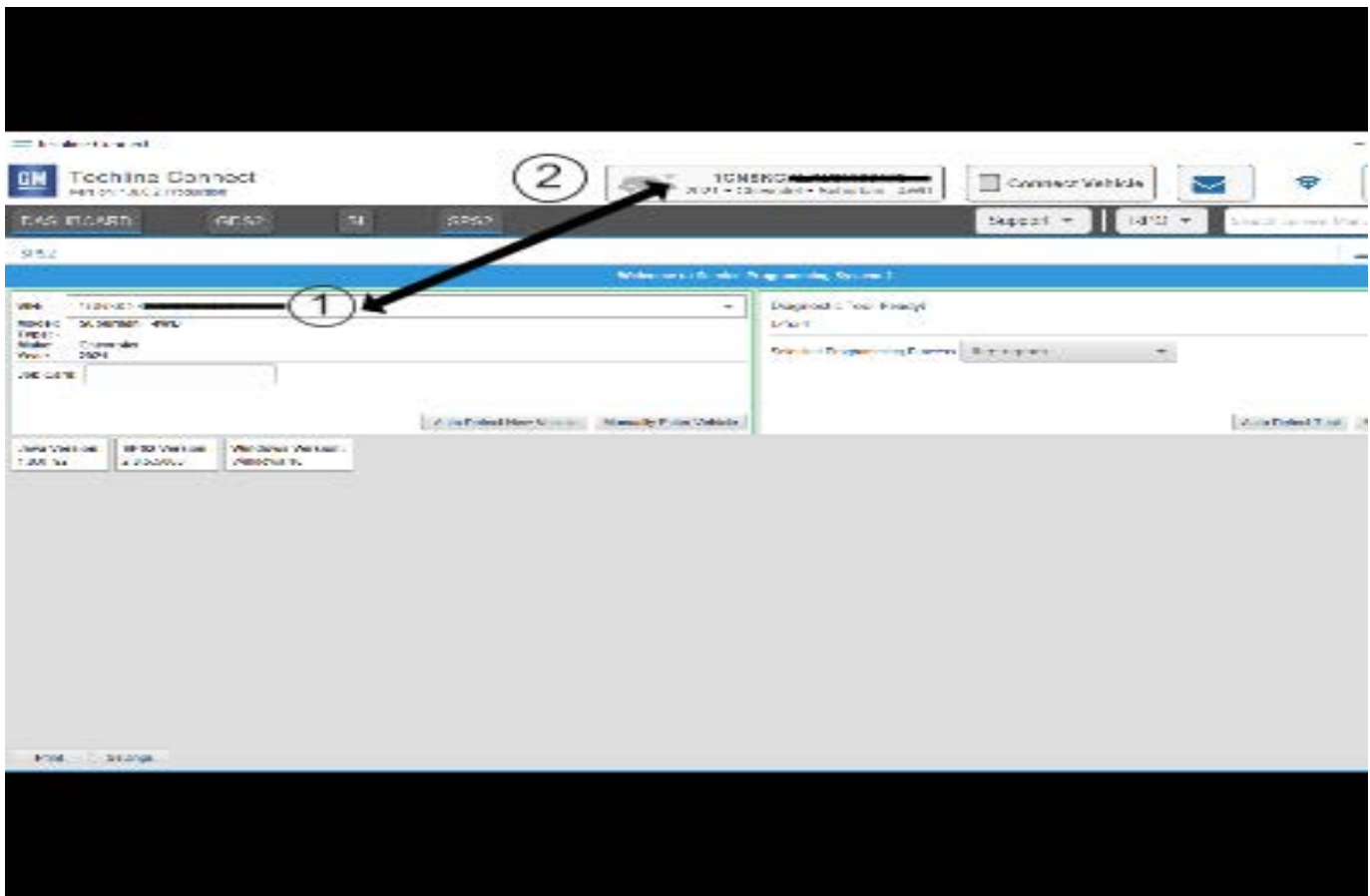

5743643

Important: If the vehicle VIN DOES NOT match, the message below will be shown.

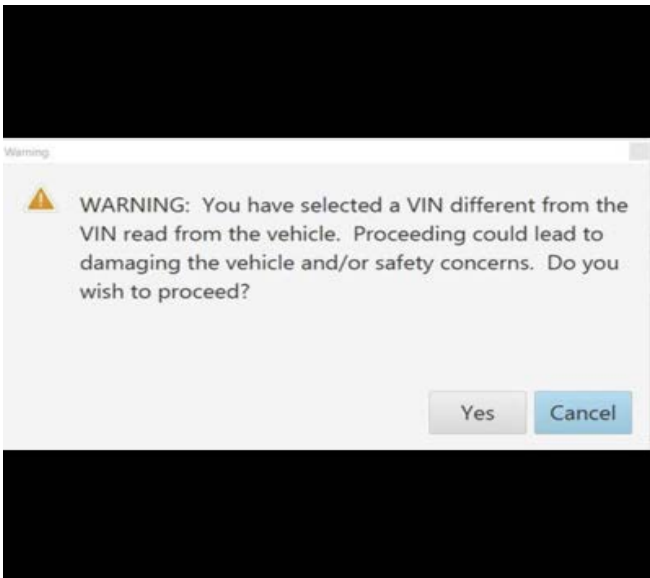

5877000

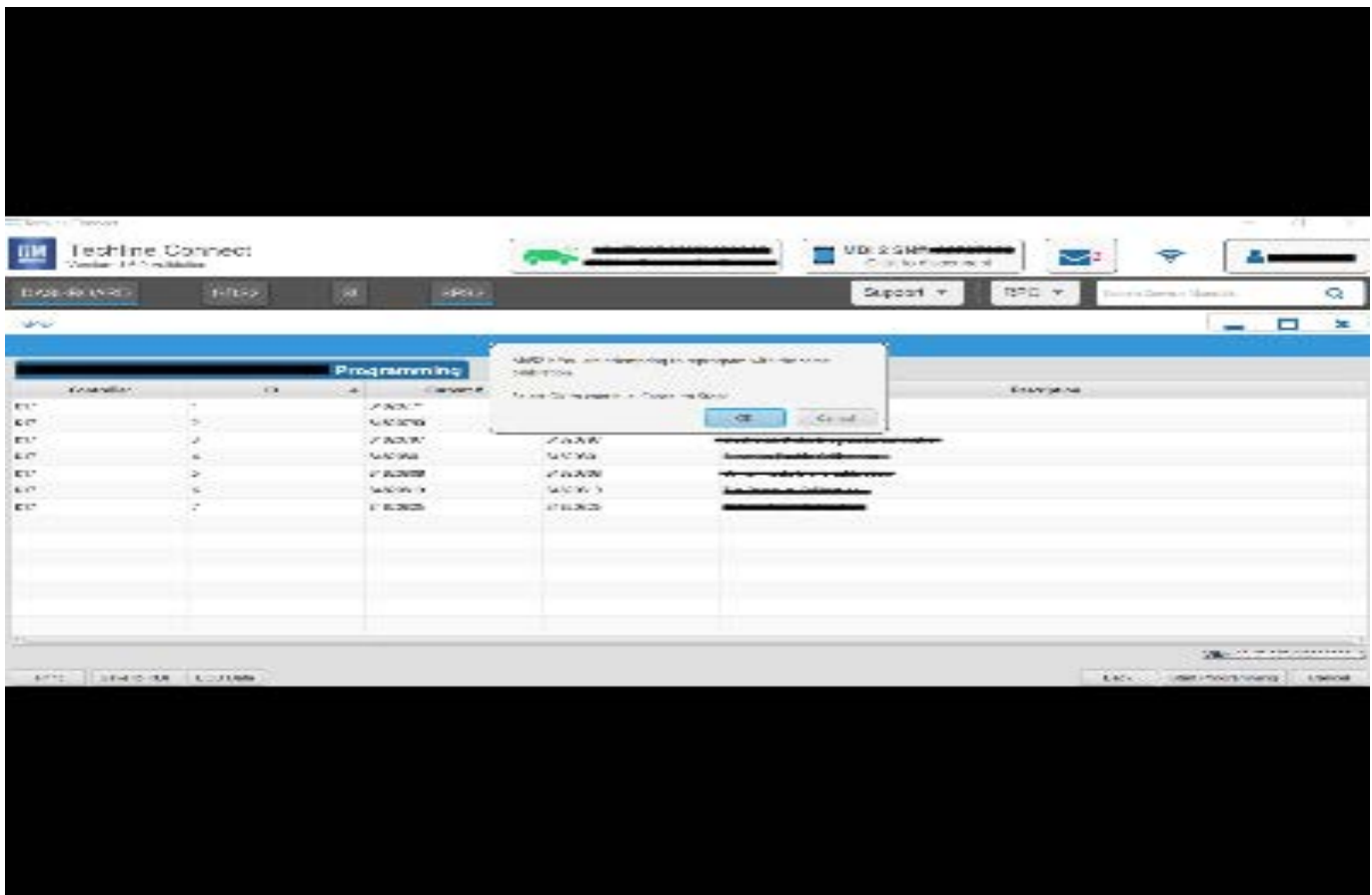

564477

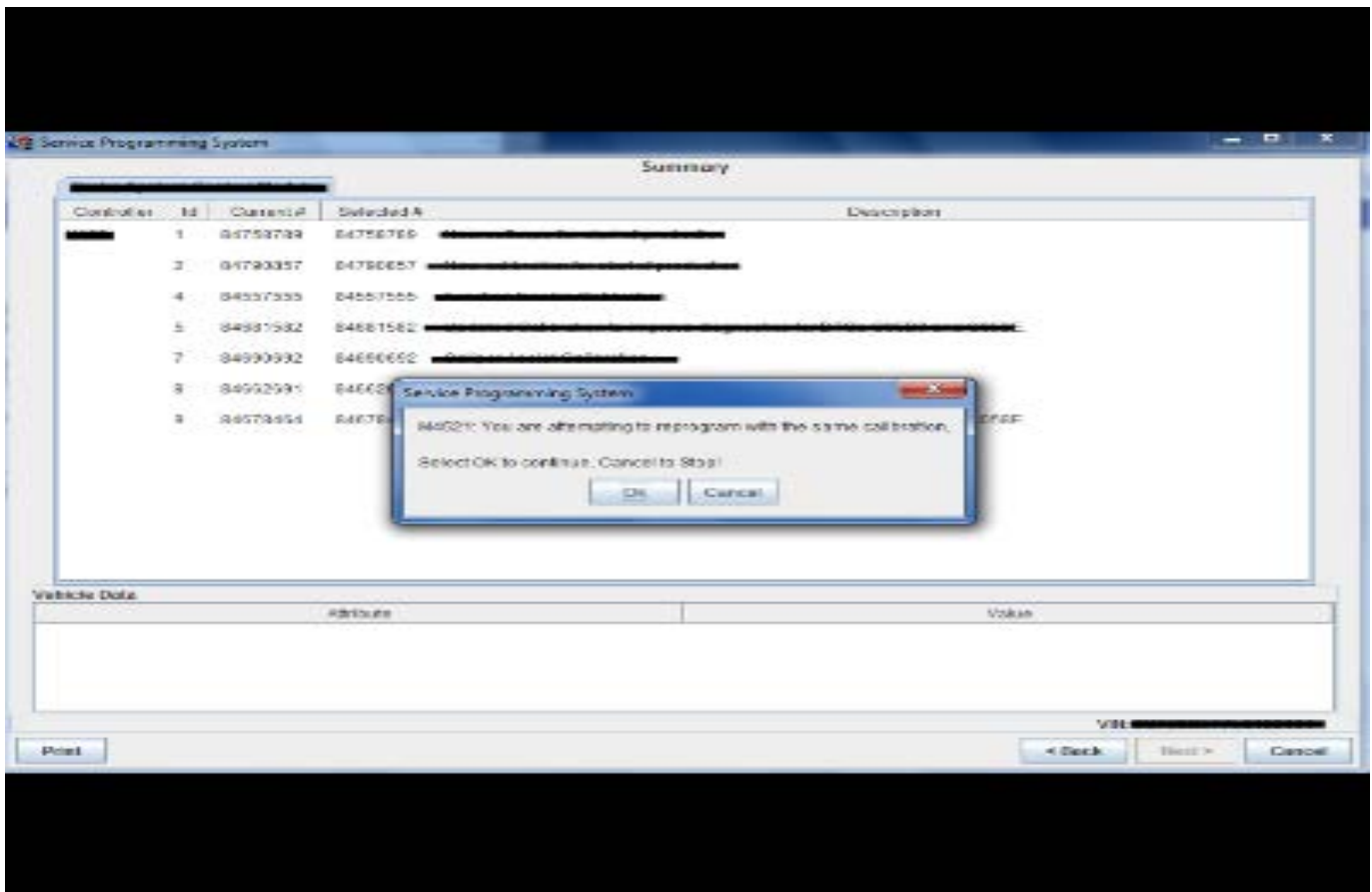

5431207

Important: Techline Connect and TIS2WEB screens shown above.

Important: If the same calibration/software warning is noted on the TLC or SPS Summary screen, select OK and follow screen instructions. After a successful programming event, the WCC is located in the Service Programming System dialogue box of the SPS Summary screen. No further action is required. Refer to the Warranty Information section of this bulletin.

1. Reprogram the ECM. Refer to *K20 Engine Control Module: Programming and Setup* in SI.



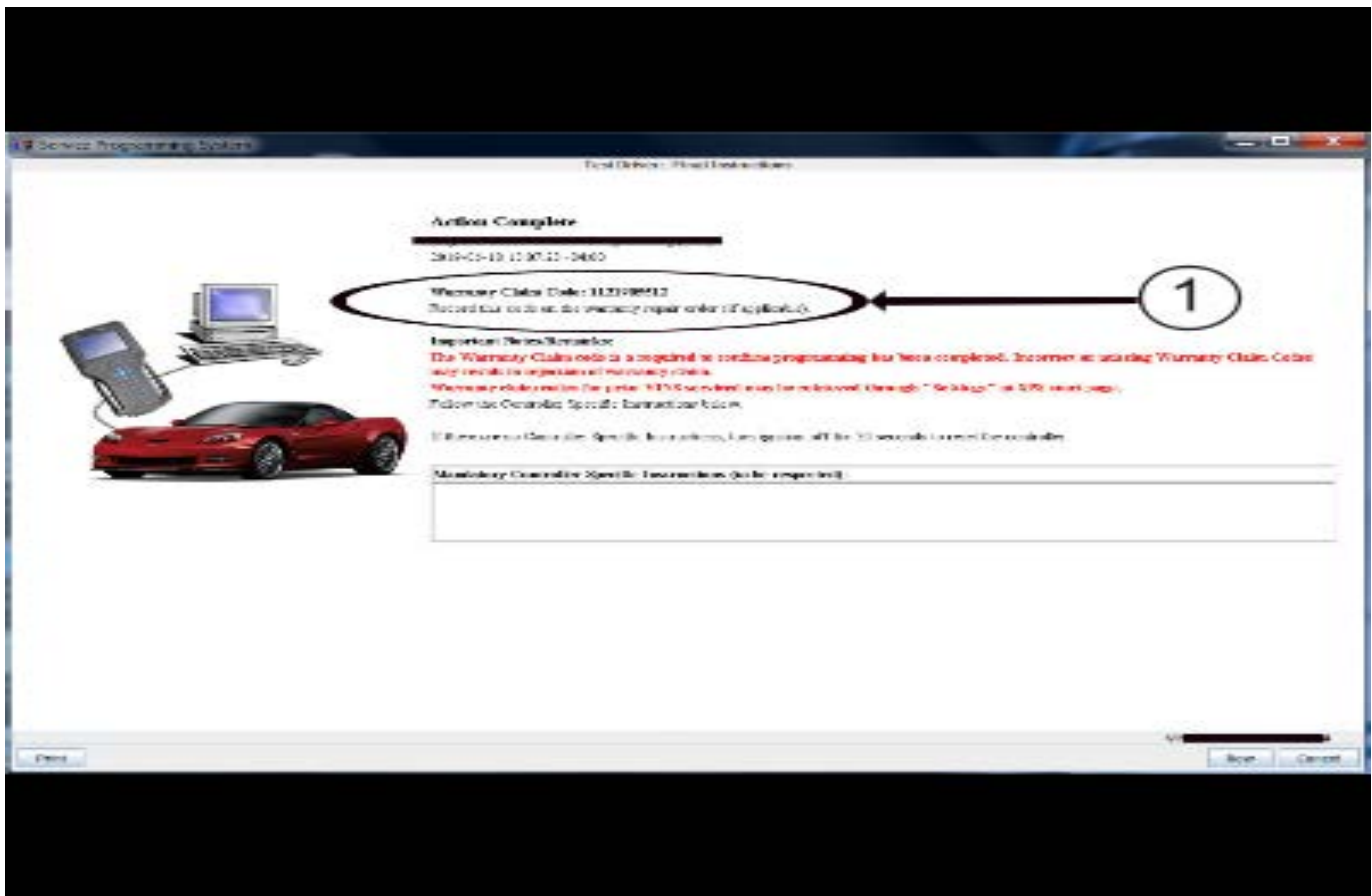

5431209

Note: The screenshots above are an example of module programming and may not be indicative of the specific module that is being programmed. Module selection and VIN information have been blacked out.

Important: To avoid warranty transaction rejections, you **MUST** record the warranty claim code provided on the SPS Warranty Claim Code (WCC) screen shown above on the job card. Refer to callout 1 above for the location of the WCC on the SPS screen.

2. Record the SPS Warranty Claim Code on the job card for warranty transaction submission.

Parts Information

Description	Model Year	Part Number	Qty
Cooler, Charge Air	2016-2020	42574036	1
	2021	Installed in Production	—
Cover, Grille Winter	2016	42697326	1
	2021–2022 (Trax)	42697331	1
	2017-2022 (Encore)	42697332	1
Filter, Oil	2016-2021	Refer to the Electronic Parts Catalog (EPC).	
Oil			

Warranty Information

Important: Emission Warranty coverage codes E (Base Emission Warranty) and E1 (California Emission Related Components 7 years/70,000 mile warranty) apply for Labor Operation 4081728.

For vehicles repaired under the Powertrain coverage, use the following labor operation. Reference the Applicable Warranties section of Investigate Vehicle History (IVH) for coverage information.

Labor Operation	Description	Labor Time
4081728*	Charge Air Cooler Replacement	1.1 hrs
Add	IAPT Inspection	0.2 hr
0580398*	Winter Grille Cover Installation	0.2 hr
Add	Oil Change	0.3 hr
Add	TCV Cleaning	0.3 hr
Add**	Engine Control Module Re-programming with SPS	0.3 hr

*This is a unique Labor Operation for bulletin use only.

Important: **To avoid warranty transaction rejections, carefully read and follow the instructions below:

- The Warranty Claim Code must be accurately entered in the "SPS Warranty Claim Code" field of the transaction.
- When more than one Warranty Claim Code is generated for a programming event, it is required to document all Warranty Claim Codes in the "Correction" field on the job card. Dealers must also enter one of the codes in the "SPS Warranty Claim Code" field of the transaction, otherwise the transaction will reject. It is best practice to enter the FINAL code provided by SPS/SPS2.

Warranty Claim Code Information Retrieval

If the SPS Warranty Claim Code was not recorded on the Job Card, the code can be retrieved in the SPS system as follows:

1. Open TLC/TIS on the computer used to program the vehicle.
2. Select and start SPS/SPS2.
3. Select Settings.
4. Select the Warranty Claim Code tab.

The VIN, Warranty Claim Code and Date/Time will be listed on a roster of recent programming events. If the code is retrievable, dealers should resubmit the transaction making sure to include the code in the SPS Warranty Claim Code field.

Version	8
Modified	<p>August 14, 2017 – Added engine RPO to Subject.</p> <p>April 12, 2018 – Updated to 2018 model year and added breakpoint and IAPT information.</p> <p>February 01, 2019 – Added the 2019 Model Year, an Important statement at beginning of bulletin, Grille Winter Cover Installation procedure and parts information, changed Intake Air Pressure and Temperature Sensor Inspection title to Turbocharger Air Pressure Sensor Inspection and updated Warranty Information.</p> <p>April 09, 2019 – Added 2019 to the Model Years for the charge air cooler in the Parts Information.</p> <p>February 12, 2021 – Added the 2020-2021 Model Years to Encore, added the Trax Model, removed the breakpoint date and updated the Model Years in Parts Information table.</p> <p>August 05, 2021 – Added the 2022 Model Year, TVC information to the Correction section, Important statement to refer to PIP5812A under Turbocharger Wastegate Regulator Solenoid Valve Inspection section and Emission Warranty coverage statement to Warranty Information.</p> <p>December 20, 2021 – Added a Note and Important in the Correction section, an Engine Control Module Programming section and ECM Programming Warranty Information.</p>

