

Noise Symptom – Clicking Noises from Around the Front Axle: Observe Specified Procedure (SY 109/21)

Revision: This bulletin replaces bulletin ATI Group 4 2106.1, dated October 7, 2021.

Model Line: **911 (991)**

Model Year: **As of 2014**

Equipment: **Central wheel lock (M-no. 478)**

Concerns: **Front wheel mounting**

Symptom: The customer complains about clicking noises from the front axle area when turning or turning at slow speeds.

Cause: Micro-movements between the contact surfaces of the wheel and brake disc may occur while driving. These micro-movements can be caused by the following main causes:

- Reduced preload on the central wheel lock
- Reduced coefficient of friction between the surfaces
- Geometric discrepancies

As a result, the rim material is removed from the brake disc.

The transferred material can weld itself to the brake disc and thus cause a stick-slip effect. This generates the clicking noises during wheel rotation.



Information

The stick-slip effect is the jerking motion that can occur while two solid bodies are sliding over each other. This phenomenon occurs when a body is moved whose static friction is significantly higher than the sliding friction.

Remedial Action: Check the components of the front wheel mounting as described below and carry out the appropriate remedial action depending on the respective test result.

When checking the components, ensure that the sequence described below is followed:

- Check central wheel lock; for instructions, see: ⇒ *Technical Information 'Checking central wheel lock'*
- Check contact surfaces of rim, brake disc and wheel hub for friction loss, see procedure: ⇒ *Technical Information 'Reduced coefficient of friction between the surfaces'*
- Check rim, brake disc and wheel hub for geometric discrepancies, see procedure: ⇒ *Technical Information 'Geometric discrepancies'*

**Information**

The wheel design with central lock was originally developed for race track driving. It allows the wheels to be changed quickly during a race. Today, the wheel and hub designs with central lock for road vehicles are significantly different to those of pure racing cars. Given this, the following guidelines and precautionary measures must always be observed when removing or installing the wheels on a road vehicle with central wheel lock.

- The vehicle must be on a lifting platform and the wheels must be hanging freely (no contact with the floor) while tightening the central lock nut. This ensures that the wheel is centered correctly on the hub.
- The parking brake must not be used to counter the rear wheels while tightening. The parking brake mechanism does not tolerate the high forces while tightening the central wheel lock and can be damaged. The damage may not be immediately apparent. This applies in particular to the motorized electronic parking brake actuators.
- Impact tools must never be used for loosening, removing or tightening the central wheel lock. The nut and hub can be damaged and the damage may not be immediately apparent.
- Only a calibrated, high-quality standard torque wrench with sufficient load capacity and levering effect may be used for tightening the central wheel lock. The use of torque multipliers is not approved for use on Porsche vehicles.
- The specified final tightening torque must be reached while turning the torque wrench with a smooth, continuous motion.
- The required lubricant must be applied to the contact surfaces of the central wheel lock and rim in accordance with regulations. For more information, see: ⇒ *Workshop Manual '440737 Disassembling and assembling central wheel lock'*
- If the central wheel lock, wheel hub or rim is new, the central wheel lock must be tightened to the specified final tightening torque, loosened and then loosened and tightened again three more times. This will eliminate any geometrical discrepancies.

Required parts and materialsParts Info: **Required parts:**

| Part No. | Designation – Location | Number |
|-------------|---|--------|
| WHT008186 | ⇒ Cheese head bolt, M12 x 1.5 x 62 – Fixed calliper on front axle – PCCB brake system M-no. 450 | 4 ea. |
| | or | |
| 99906704001 | ⇒ Cheese head bolt, M12 x 1.5 x 95 – Fixed calliper on front axle – Grey cast iron brake system | 4 ea. |

Materials: **Required materials** (usually already available at the Porsche dealer):

| Part No. | Designation | Quantity |
|-------------|---|------------------|
| 00004330508 | ⇒ Mounting paste (100 gram/ 3.52 oz tube) | 2 grams/ 0.07 oz |

Required tools

- Tool:
- Straight-edge, e.g. 12" Starret 380
 - Feeler gauge, 0.05 mm
 - Brass brush
 - Microfiber cloth
 - Brake cleaner
 - **9451 - Socket wrench**
 - **9794 - Assembly aid**
 - **9796 - Socket wrench**

Preparatory work

Work Procedure: 1 Remove front wheels. ⇒ *Workshop Manual '440519 Removing and installing wheel with central bolt'*

Checking central wheel lock



Information

Reduced preload on the central wheel lock may be due to:

- Reduced amount of grease on the cone of the central wheel lock or on the thread and external diameter of the wheel hub
- A damaged central wheel lock bolt
- A damaged cone on the rim



Information

If one or more of the central bolts is damaged, it must be replaced. Make sure that the central bolt is sufficiently greased. For instructions, see: ⇒ *Workshop Manual '440737 Disassembling and assembling central wheel lock'*

- Work Procedure: 1 Disassemble central wheel lock.
For instructions, see:
⇒ *Workshop Manual '440737 Disassembling and assembling central wheel lock'*
- 2 Check central wheel lock for sufficient lubricating film ⇒ *Lubricating film on central wheel lock*, cracks, deformation ⇒ *Example of damage* and other damage. Damage can occur at the following points:
- Wheel hub thread
 - Central wheel lock thread
 - Cone on rim
 - Cone on central wheel lock

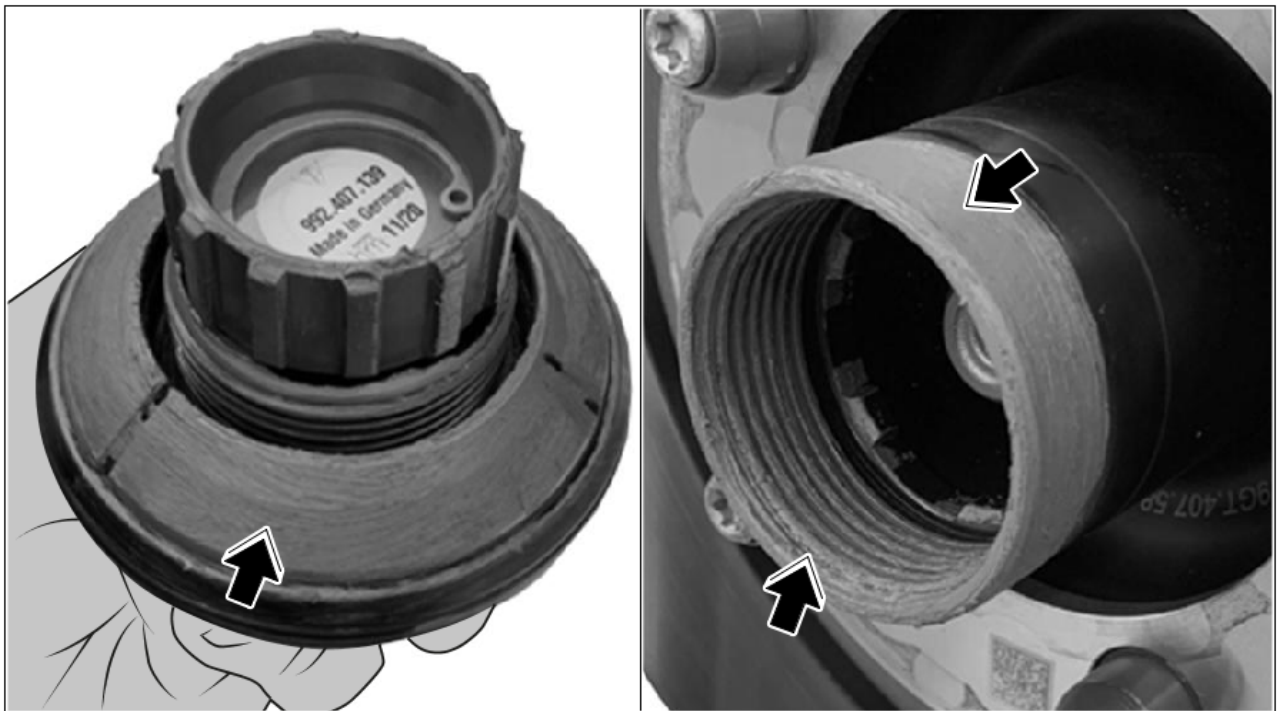

Lubricating film on central wheel lock

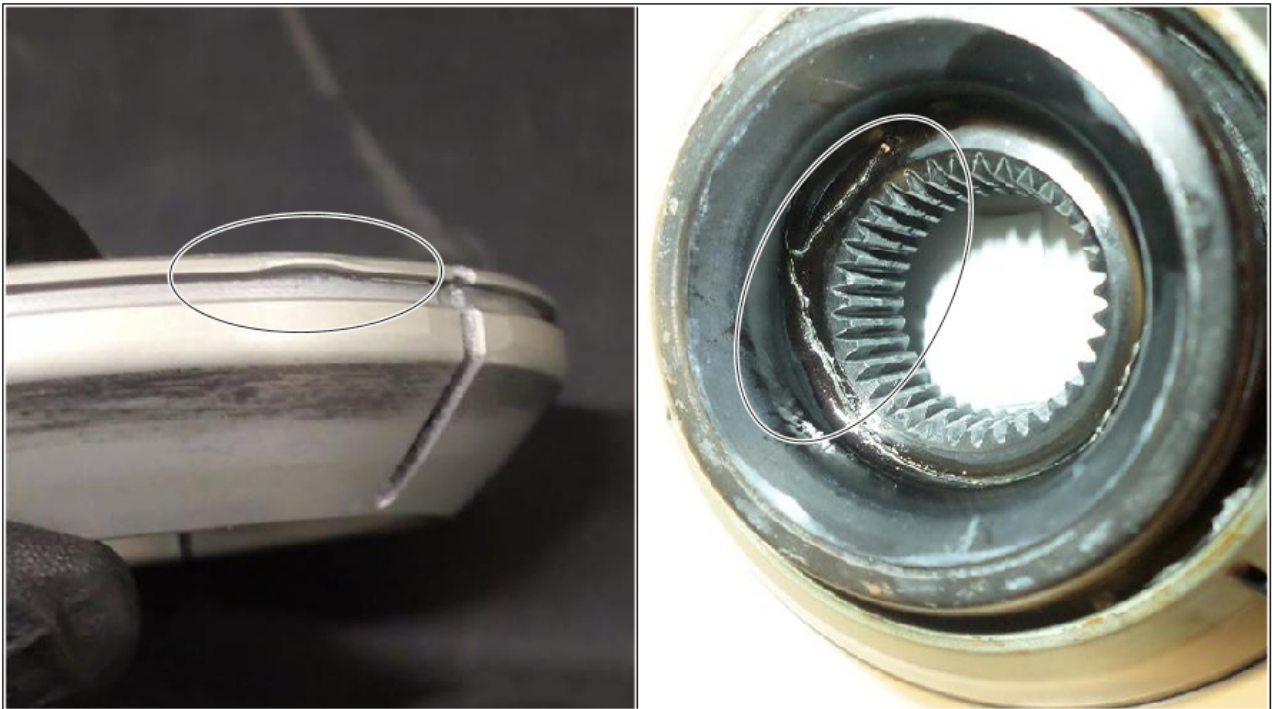

Example of damage

**Information**

If using new parts, the procedure for tightening the wheel as described in the Workshop Manual ⇒ *Workshop Manual '440519 Removing and installing wheel with central bolt'* must be carried out **three times**.

Parts Info:

Parts required if necessary for one side of the vehicle:

| Part No. | Designation – Location | Number |
|-------------|--------------------------------------|--------|
| 99136108190 | ⇒ Wheel bolt – Central wheel lock | 1 ea. |
| | or | |
| 99970766340 | ⇒ O-ring – Central wheel lock | 1 ea. |
| | or | |
| 99136118900 | ⇒ Washer – Central wheel lock | 1 ea. |
| | or | |
| 99736118700 | ⇒ Circlip – Central wheel lock | 1 ea. |

Check contact surfaces of the rim, brake disc and wheel hub for loss of friction**Information**

A reduced friction coefficient between the surfaces can be due to:

- Material transfer from rim to brake disc or from rim to driver pin
- Anti-corrosion oil on the contact surfaces
- Contact surfaces dirty, e.g. brake dust
- Hub grease on the contact surface

Work Procedure: 1 Check the mounting surface of the wheel hub and inside of the rim for material transfer or corrosion.
⇒ *Material transfer for brake disc/wheel hub*

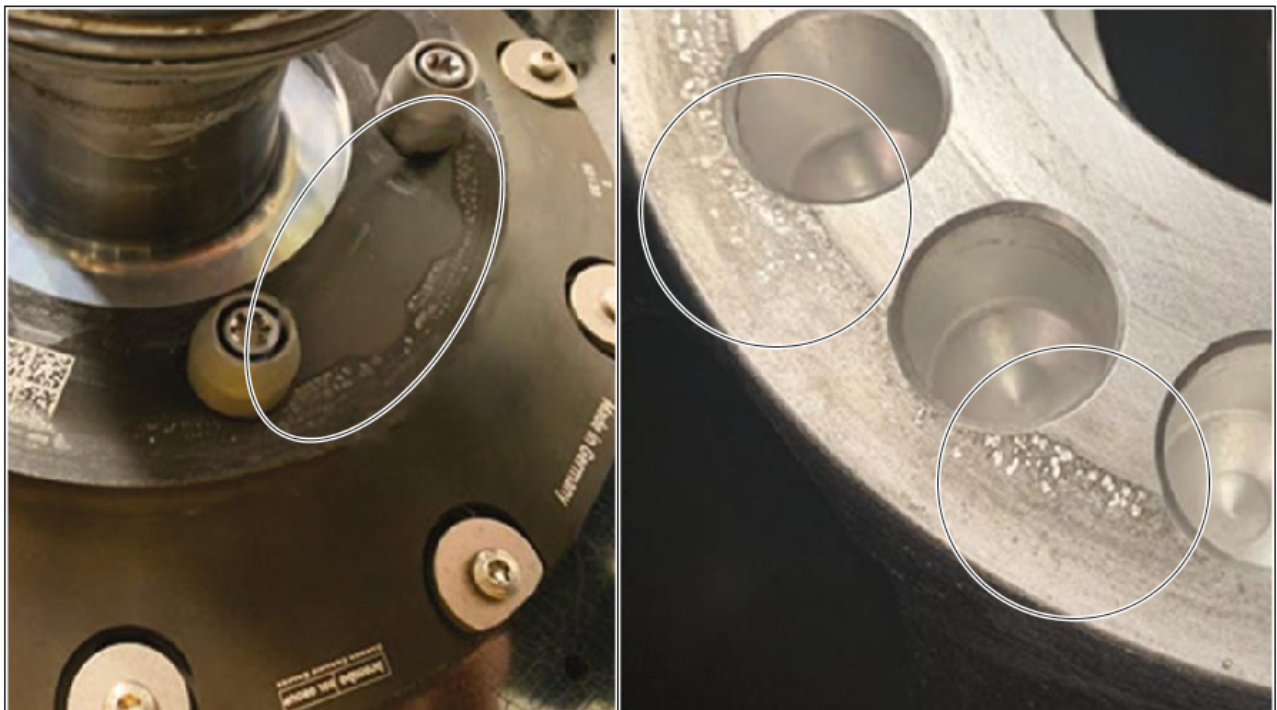

Material transfer for brake disc/wheel hub

**Information**

If there has been material transfer from the rim to the brake disc, the brake disc must be replaced. For instructions, see:

⇒ *Workshop Manual '465019 Removing and installing front brake disc'*

- 2 Document material transfer or corrosion, if available, with pictures.
- 3 Remove front brake discs. ⇒ *Workshop Manual '465019 Remove and install front brake disc'*
- 4 Check contact surface of brake disc, wheel hub and rim for dirt and clean them if necessary.

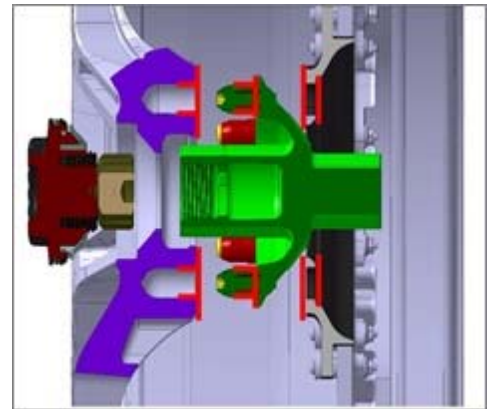
4.1 Clean wheel assembly:

Contact surfaces of brake disc, wheel hub, rim

Brush off wheel hub (⇒ *Cleaning wheel hub -1-*) using a brass brush until all particles of dirt have been removed. Then spray microfiber cloth with brake cleaner and rub off the wheel hub (⇒ *Cleaning wheel hub -1-*) with it.

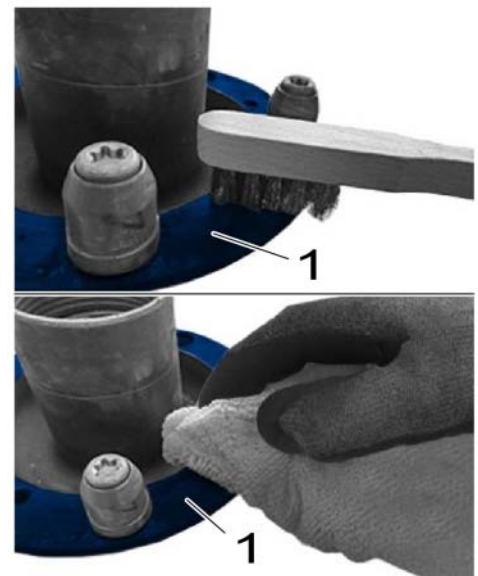

Cleaning wheel hub

- 4.2 Clean brake dust off the inner brake disc hub (⇒ *Cleaning brake disc hub -1-*) and brush off the contact surface between the brake disc and wheel hub (⇒ *Cleaning brake disc hub -2-*) using a brass brush until all particles of dirt have been removed. Then, spray microfiber cloth with brake cleaner and rub off the cleaned areas with it.

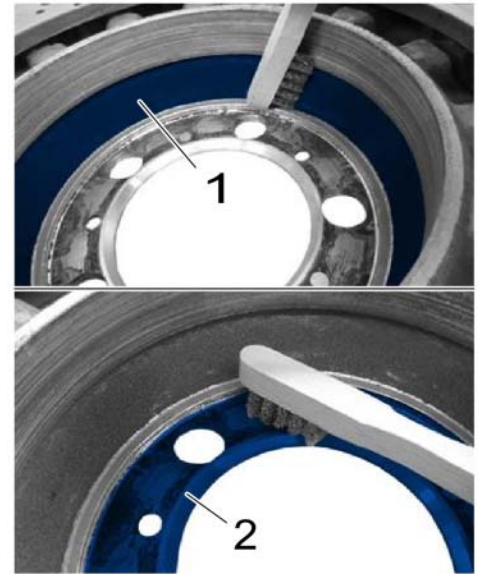

Cleaning brake disc hub

- 4.3 Clean the contact surfaces between the rim and brake disc (⇒ *Contact surfaces between rim and brake disc -1 und 2-*) using a microfiber cloth and brake cleaner (**do not use a brass brush**).



Information

Always make sure that the cleaned surfaces are kept clean until assembly is complete.

- 5 Check driving pins.

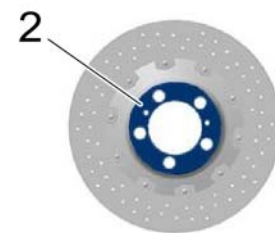
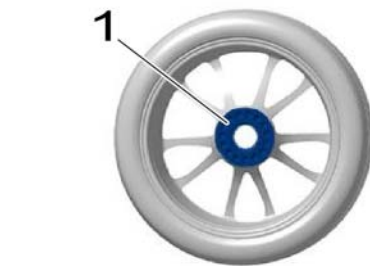

Contact surfaces between rim and brake disc

- 5.1 Check material transfer at the driving pins. If a material transfer has taken place, the driving pins must be replaced. ⇒ *Material transfer on driving pin*
- 5.2 **Subsequent torque 22 Nm** of threaded joint for wheel driver pin and then remove brake disc. If the pins can still be turned, replace pins and screws and clean the thread and contact surfaces to remove any remaining screw-locking material.
- ⇒ *Workshop Manual '465319 Removing and installing rear brake disc'*
- ⇒ *Workshop Manual '465419 Removing and installing rear PCCB brake disc'*
- 5.3 Check wheel driver pins for damage. If there are visible signs of damage, replace pins and screws and clean the thread and contact surfaces to remove any remaining screw-locking material.



Material transfer on driving pin



Information

If using new parts, the procedure for tightening the wheel as described in the Workshop Manual ⇒ *Workshop Manual '440519 Removing and installing wheel with central bolt'* must be carried out **three times**.

Checking rim, brake disc and wheel hub for geometric discrepancies



Information

Geometrical discrepancies may be due to the following factors:

- Damaged parts
- Wear
- Use of new and old parts

Work Procedure: 1 Check brake discs, wheel hub and rim for damage, e.g. notches or "dents" due to incorrect assembly.
⇒ *Example of damage*



Example of damage

2 Check contact surface of the rim.
To ensure that the surface is flat, check the rim using a ruler and feeler gauge.
Uneven surfaces can affect the rim and cause noise.

2.1 Check the inside of the rim for flatness at at least six different positions (approx. every 60°) using a straight edge (e.g. 12" Starret 380) and a feeler gauge 0.05 mm at the measuring points ⇒ *Measuring points on inside of rim -Arrow-*.

Document all measurements with photos.



Checking rim

If there are uneven surfaces, replace the affected rim.



Information

If using new parts, the procedure for tightening the wheel as described in the Workshop Manual ⇒ *Workshop Manual '440519 Removing and installing wheel with central bolt'* must be carried out **three times**.

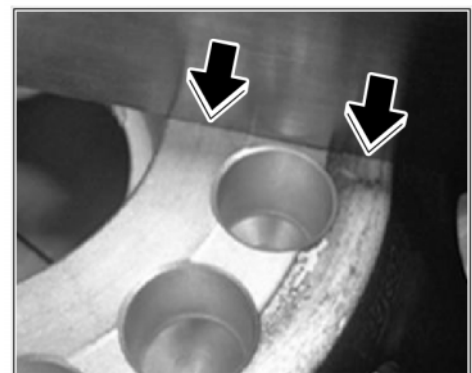

Measuring points on inside of rim

Concluding work

Work

Procedure:

**Information**

When installing a wheel, the **three tightening steps** must always be observed as described in the Workshop Manual ⇒ *Workshop Manual '440519 Removing and installing wheel with central bolt'* and the following special tools must be used:

- **9451 - Socket wrench**
- **9794 - Assembly aid**
- **9796 - Socket wrench**

The central bolt must be tightened in one **continuous movement**. This is the only way to ensure that the specified tightening torque is reached.

- 1 Install front brake discs. ⇒ *Workshop Manual '465019 Remove and install front brake disc'*
- 2 Install front wheels. ⇒ *Workshop Manual '440519 Removing and installing wheel with central bolt'*

Invoicing

Invoicing:

For documentation and warranty invoicing, enter the labor operations, PCSS coding and part numbers specified below in the warranty claim:

| APOS | Labor operation | I No. |
|----------|----------------------------------|-------|
| 44074941 | Reworking wheel mounting (left) | |
| 44074942 | Reworking wheel mounting (right) | |

PCSS coding:

| | | |
|-------------------|-------|--|
| Location (FES5) | 4407A | Central bolt for wheel mounting |
| Damage type (SA4) | 9735 | Repair in accordance with PAG instructions |

- References:
- ⇒ *Workshop Manual '440519 Removing and installing wheel with central bolt'*
 - ⇒ *Workshop Manual '440737 Disassembling and assembling central wheel lock'*
 - ⇒ *Workshop Manual '465019 Removing and installing front brake disc'*

Important Notice: Technical Bulletins issued by Porsche Cars North America, Inc. are intended only for use by professional automotive technicians who have attended Porsche service training courses. They are written to inform those technicians of conditions that may occur on some Porsche vehicles, or to provide information that could assist in the proper servicing of a vehicle. Porsche special tools may be necessary in order to perform certain operations identified in these bulletins. Use of tools and procedures other than those Porsche recommends in these bulletins may be detrimental to the safe operation of your vehicle, and may endanger the people working on it. Properly trained Porsche technicians have the equipment, tools, safety instructions, and know-how to do the job properly and safely. Part numbers listed in these bulletins are for reference only. The work procedures updated electronically in the Porsche PIWIS diagnostic and testing device take precedence and, in the event of a discrepancy, the work procedures in the PIWIS Tester are the ones that must be followed.

© 2021 Porsche Cars North America, Inc.