



SIB 61 11 21

SERVICE ACTION: CHARGING FAN DIODE RETROFIT

2021-11-23

This Service Information Bulletin replaces SI 61 11 21 **dated September 2021**.

What's New:

- Integration Level information updated.

MODEL

Model	Model Description	Model Year
K17	C Evolution	2016 and onward

The affected vehicles have been marked with campaign number **0061460000** in AIR.

In order to determine if a specific vehicle is affected by this campaign it will be necessary to verify the vehicle VIN in AIR (Aftersales Information Research). Based on the response of the system, either proceed with the repair or take no further action. Please note, open campaigns or vehicle stops may not appear in DCS Warranty Vehicle Inquiry or sales systems until 24-72 hours after they are announced, therefore AIR is always the recommended method for determining open campaigns and vehicle stops.

SITUATION

With the introduction of the Silent Charge function for model year 2016, the control of the charging fan was reconfigured for its implementation. In rare cases, it is possible for the charging fan to cause voltage spikes and damage the electrical machine electronics (EME) module.

If this EME damage occurs, the charging fan will run continuously as soon as the ignition is switched on.

CORRECTION

To protect the EME module, affected vehicles need to be retrofitted with a flyback diode for the charging fan.

PROCEDURE

In affected vehicles, install the additional wiring harness per the attached Repair Instructions "00 60 382 – Retrofitting flyback diode for fan" at the next workshop visit or in case of a complaint.

To be considered a completed repair, additional PROGRAMMING and RETROFIT are required in ISTA:

In addition to the installation of the additional wiring harness, the retrofit "Flyback diode for fan" must be carried out with ISTA, I level K001-20-03-501 or newer:

- Program motorcycle to the newest I-Level using ISTA version 4.28.1x or later (integration level K001-20-03-501 or newer)
- Perform "Flyback diode for fan" retrofit using ISTA version 4.28.1x or later (integration level K001-20-03-501 or newer).

PARTS INFORMATION

Part Number

61 11 1 639 604	ZB K17 Fan ILM adapter cable
-----------------	------------------------------

WARRANTY INFORMATION

Covered under the terms of the BMW New Vehicle Limited Warranty for Motorcycles, if applicable.

Defect code

00 61 46 00 00	Retrofitting flyback diode for fan
----------------	------------------------------------

Labor Operation

+00 60 882	Retrofit free-wheeling diode for fan	6 FRU
------------	--------------------------------------	-------

FRUs includes all repair procedures to complete the task with allowance for necessary ancillary tasks (e.g., visual inspection, lubrication, cleaning parts etc.) and administrative tasks.

QUESTIONS REGARDING THIS BULLETIN

Technical inquiries	Contact the BMW Technical Support Group via TSARA
Warranty inquiries	Submit an IDS ticket to the Warranty Department
Parts inquiries	Submit an IDS ticket to the Motorrad Parts Department

Supporting Materials

[picture_as_pdf RM_0060382_0061460000_EN.pdf](#)

[picture_as_pdf 61 11 21 Service Action Cooling Fan Diode Retrofit.pdf](#)

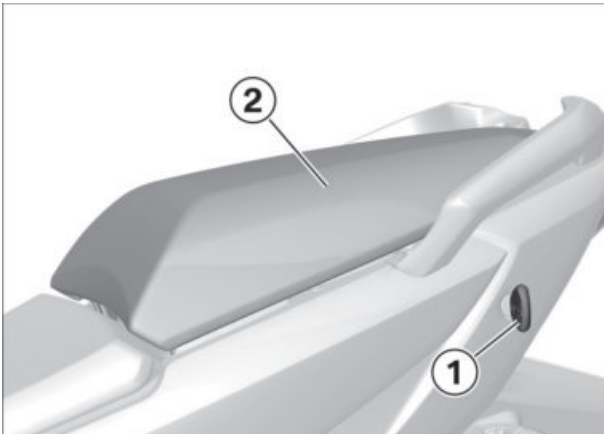
0C03 - C evolution**00 60 382 Retrofit free-wheeling diode for fan****1****► Removing rear seat**

- Use vehicle key **(1)** to unlock the seat lock and open rear seat **(2)**.

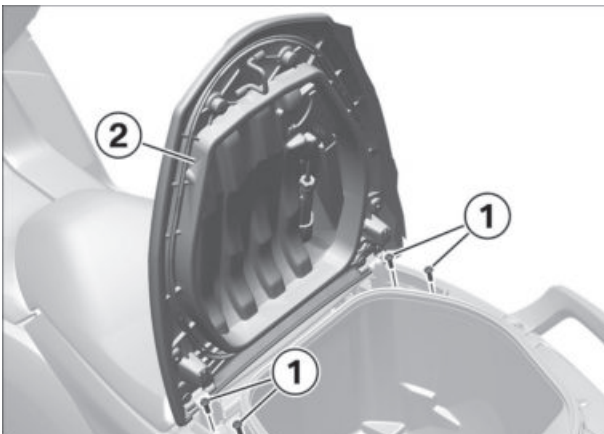

- Remove screws **(1)** and remove rear seat **(2)**.

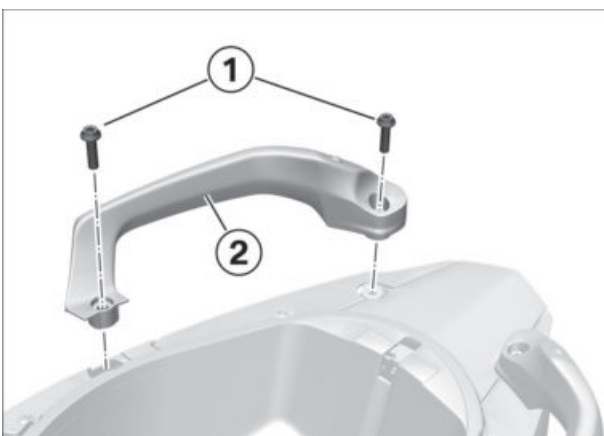
2**► Removing right rear grab handle**

- Remove screws **(1)** and remove rear grab handle **(2)**.

3

▶ Removing front seat

 NOTICE

There is a possibility of the threaded bushings working loose from the high-voltage battery unit when the trim panels are being removed. Check the security of the threaded bushings and, if necessary, use an Allen key to tighten them.

- Remove screws **(1)** and carefully ease front seat **(2)** forward, noting the locators **(arrows)**.

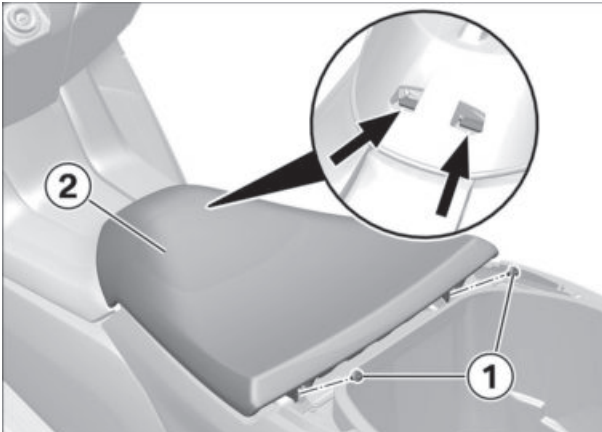

4

▶ Removing right gap trimmer panel

- Operate retaining hook **(1)** and remove gap trimmer panel **(2)** from rear trim panel **(3)**, noting the locator **(arrow)**.

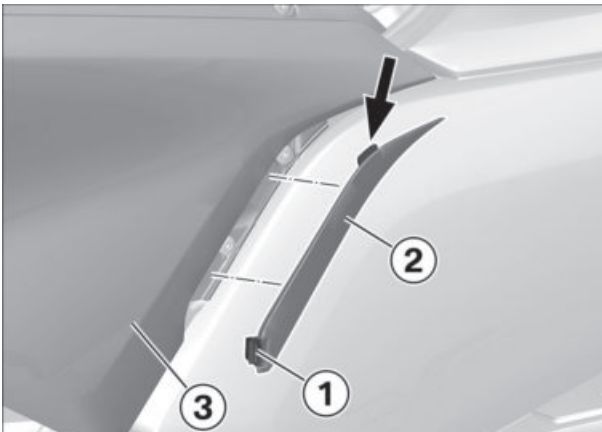

5

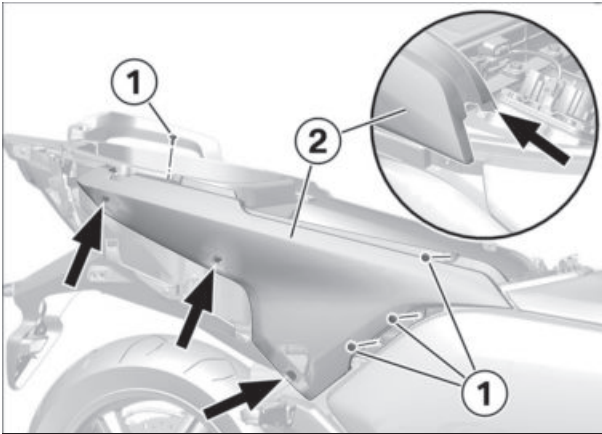

► **Removing right rear side panel**

- Remove screws **(1)** and remove right rear side panel **(2)**, noting the locators **(arrows)**.

6

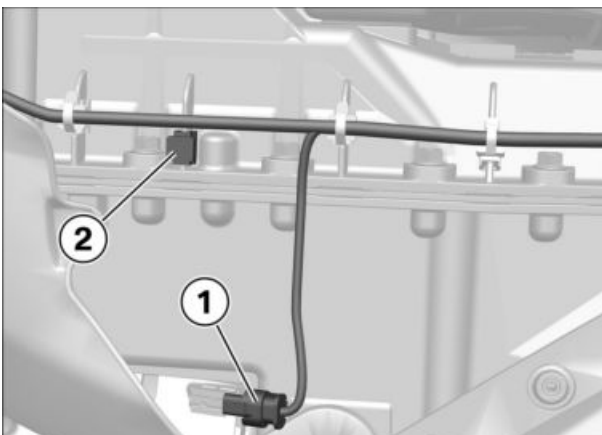

► **Installing flyback diode for fan**

- Disconnect connector **(1)** for the fan.
- Install cable holder **(2)**.

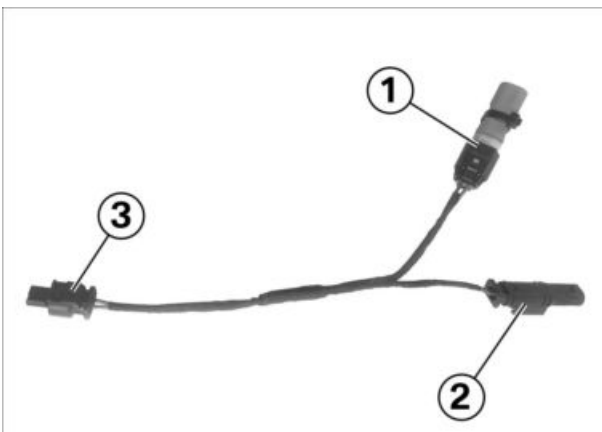

- Overview of additional wiring harness for flyback diode.

- Connector **(1)** flyback diode.
- Connector **(2)** to wiring harness.
- Connector **(3)** to fan.

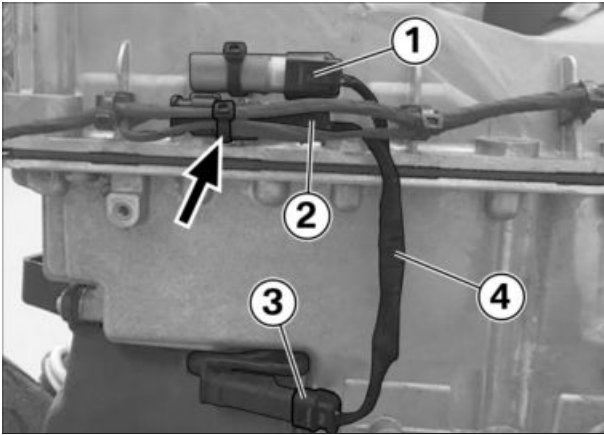

- Connect connector (3) with connector for fan
- Connect connector (2) with wiring harness.
- Route additional wiring harness (4).
- Secure flyback diode (1) with cable clip.
- Secure the cable strap (arrow).



7

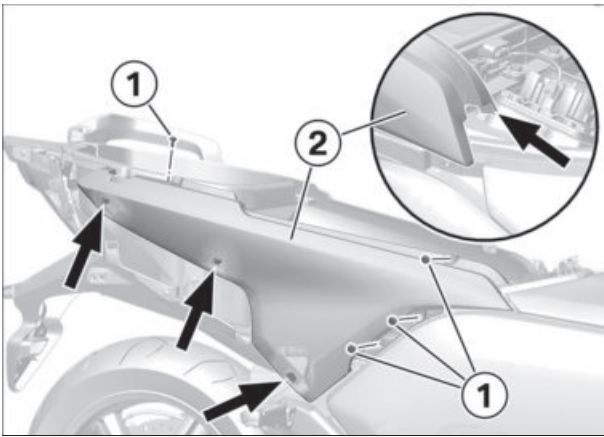

► **Installing right rear side panel**

- Hold right rear side panel (2) in position, noting the locators (arrows).
- Install screws (1).



8

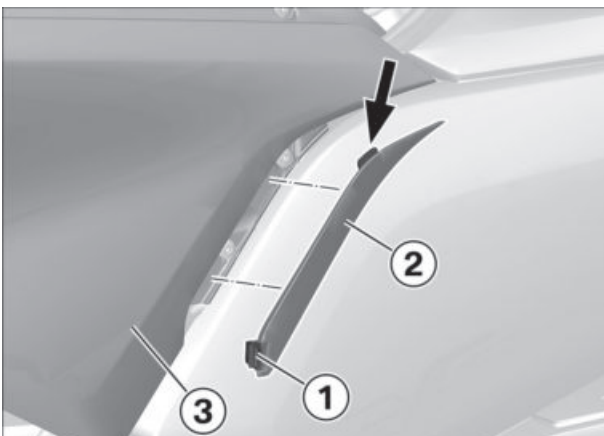

► **Installing right gap trimmer panel**

- Insert gap trimmer panel (2) in rear trim panel (3), noting the locator (arrow).
- » Retaining hook (1) engages.



9

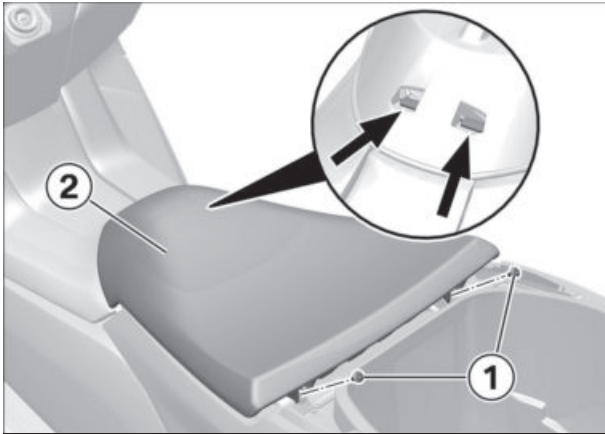

► **Installing front seat**

- Seat front seat (2) in the locators (arrows) and install screws (1).

 Tightening torques		
Front seat to service cap		
M5 x 14.5	5 Nm	

10

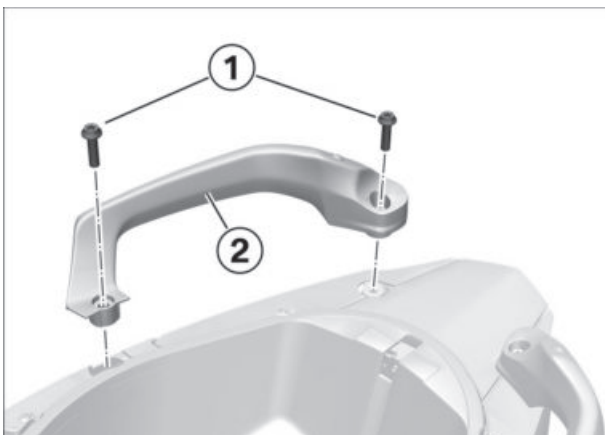

► **Installing right rear grab handle**

- Hold rear grab handle (2) in position and install screws (1).

 Tightening torques		
Rear grab handle to rear frame		
M8 x 30	19 Nm	

11

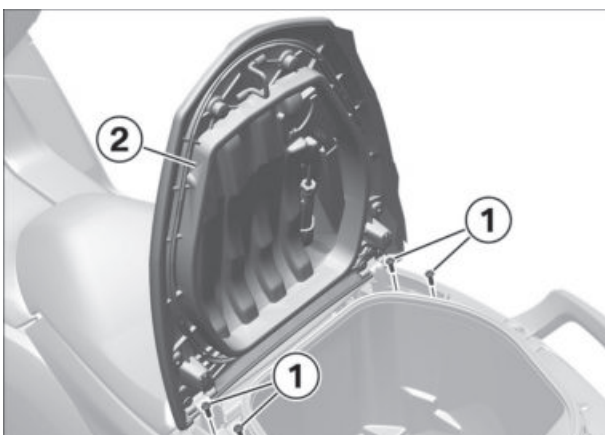

► **Installing rear seat**

- Hold rear seat (2) in position and install screws (1).

 Tightening torques		
Hinge for rear seat to rear frame		
M6 x 16	8 Nm	

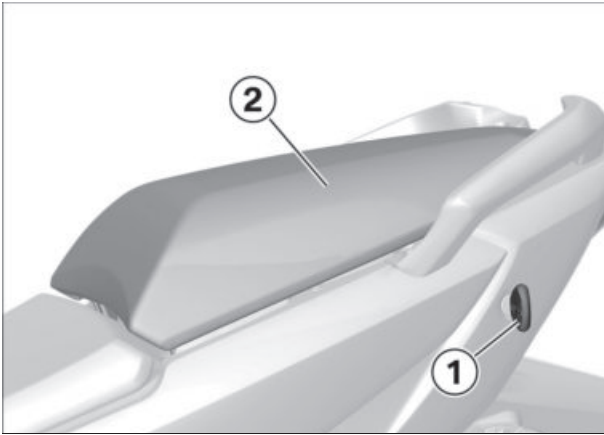

- Close rear seat **(2)** and press down to lock.
- Remove vehicle key **(1)**.



12

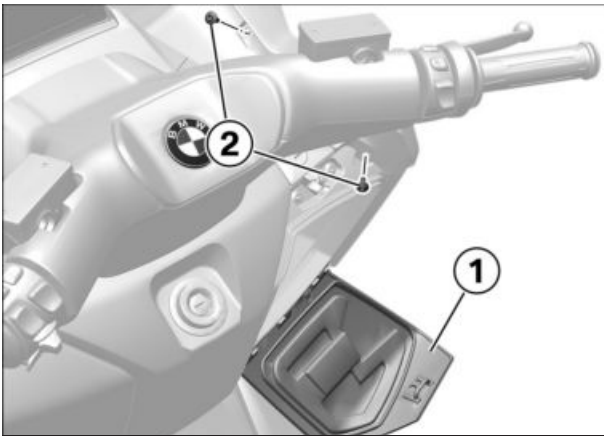

► Removing front right side panel

- Open storage compartment cover **(1)**.
- Remove screws **(2)**.

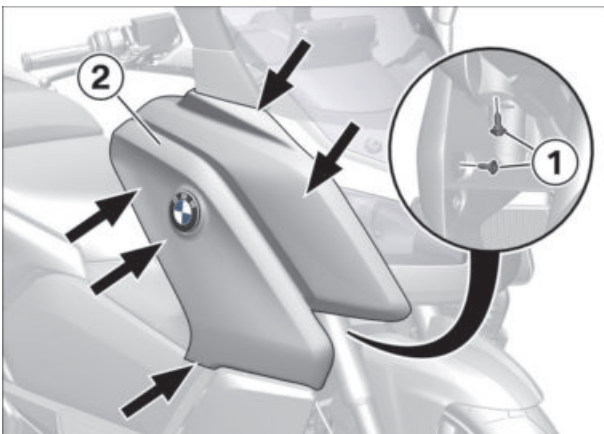

- Remove screws **(1)**.
- Remove side panel **(2)**, noting the locators **(arrows)**.



13

► Connecting BMW Motorrad diagnostic system to E-Scooter

- Connect the BMW Motorrad battery charger to the **bat-tery**.

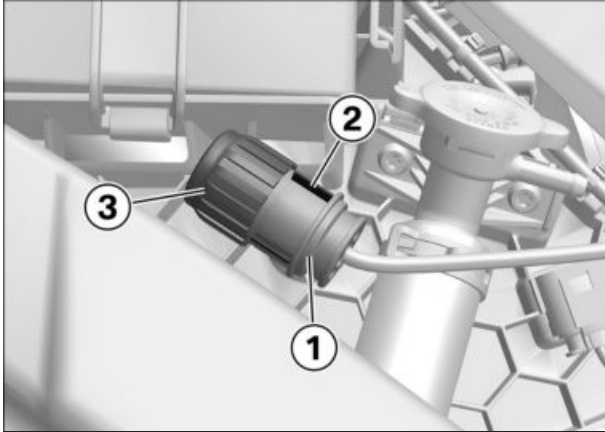

NOTICE

When carrying out diagnosis and programming, use a battery charger with 30 A approved by BMW Motorrad that ensures an **on-board system voltage of 13 V**.

- Release diagnostic connector (1) from holder (2) and unscrew protective cap (3).
- Connect diagnosis plug (1) to the BMW Motorrad diagnostic system.

NOTICE

See the information about the BMW Motorrad diagnostic system for all further instructions.

14

▶ Checking the software with the BMW Motorrad diagnosis system

- Start the diagnosis system.
- Read out the software release.
- Perform diagnosis. Rectify faults, if found, **before** starting programming/coding.

15

▶ Programming the vehicle control unit with BMW Motorrad diagnosis system

- Start the programming routine and follow the instructions issued by the diagnostic system.

16

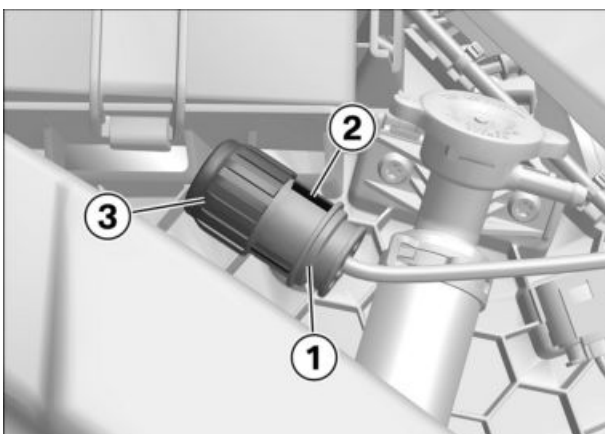

▶ Disconnect the BMW Motorrad diagnostic system from E-Scooter

- Close all diagnostic programs and switch off the ignition.
- Disconnect the BMW Motorrad diagnostic system from diagnosis plug (1) and install cap (3).
- Secure diagnosis plug (1) in holder (2).
- Disconnect the BMW Motorrad battery charger from the E-Scooter.

17

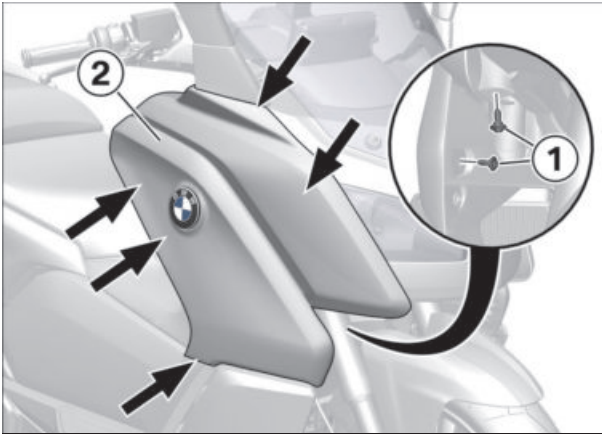
► **Install the front right side panel**

- Install top side panel **(2)**, noting the locators **(arrows)**.
- Install screws **(1)**.

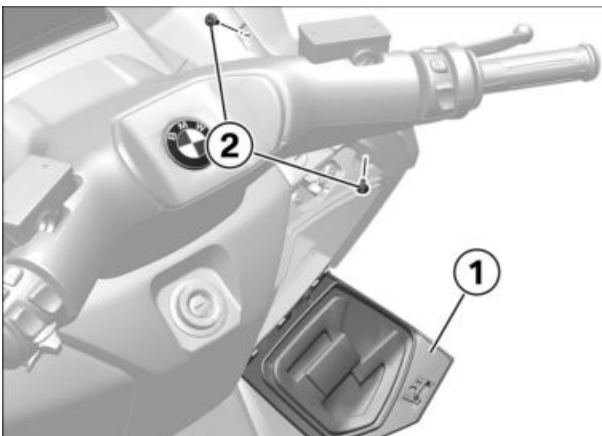

- Install screws **(2)**.
- Shut storage compartment lid **(1)**.

18

► **Final check of work performed**

- Check the following:
 - The work as performed achieved the intended purpose.
 - All reservoirs and containers have been filled and all fluids and lubricants are at their correct levels.
 - All threaded fasteners released beforehand have been correctly retightened.
 - The lights and signalling equipment are fully operational and the vehicle is roadworthy.
 - The brake pads of the front and rear brakes are bedded against the brake discs.

▷ **Function check, start enabling****Check**

- Switch on the vehicle.
- Set kill switch to operating position (run).
- Extend the side stand.
- Press the start enabling button.
- » Vehicle **does not** start.

- Retract the side stand.
- Press the start enabling button.
 - » Vehicle **does not** start.
- With the brakes applied, press the start enabling button.
 - » Vehicle starts.

Result

Not all test steps completed successfully.

Measure

- Run the "Vehicle start enabling" troubleshooting routine and check the appropriate parts with the BMW Motorrad diagnostic system.



SERVICE ACTION: CHARGING FAN DIODE RETROFIT



This Service Information Bulletin replaces SI 61 11 21 dated September 2021.

What's New:

- Integration Level information updated.

MODEL

Model	Model Description	Model Year
K17	C Evolution	2016 and onward

The affected vehicles have been marked with campaign number 0061460000 in AIR.

In order to determine if a specific vehicle is affected by this campaign it will be necessary to verify the vehicle VIN in AIR (Aftersales Information Research). Based on the response of the system, either proceed with the repair or take no further action. Please note, open campaigns or vehicle stops may not appear in DCS Warranty Vehicle Inquiry or sales systems until 24-72 hours after they are announced, therefore AIR is always the recommended method for determining open campaigns and vehicle stops.

SITUATION

With the introduction of the Silent Charge function for model year 2016, the control of the charging fan was reconfigured for its implementation. In rare cases, it is possible for the charging fan to cause voltage spikes and damage the electrical machine electronics (EME) module.

If this EME damage occurs, the charging fan will run continuously as soon as the ignition is switched on.

CORRECTION

To protect the EME module, affected vehicles need to be retrofitted with a flyback diode for the charging fan.

PROCEDURE

In affected vehicles, install the additional wiring harness per the attached Repair Instructions "00 60 382 – Retrofitting flyback diode for fan" at the next workshop visit or in case of a complaint.

To be considered a completed repair, additional PROGRAMMING and RETROFIT are required in ISTA:

In addition to the installation of the additional wiring harness, the retrofit "Flyback diode for fan" must be carried out with ISTA, I level K001-20-03-501 or newer.

- Program motorcycle to the newest I-Level using ISTA version 4.28.1x or later (integration level K001-20-03-501 or newer)
 - **TIP:** Switch Ignition ON before connecting the ICOM for quicker programming.
- Perform "Flyback diode for fan" retrofit using ISTA version 4.28.1x or later (integration level K001-20-03-501 or newer).

PARTS INFORMATION

Part Number

61 11 1 639 604	ZB K17 Fan ILM adapter cable
-----------------	------------------------------

WARRANTY INFORMATION

Covered under the terms of the BMW New Vehicle Limited Warranty for Motorcycles, if applicable.

Defect code

00 61 46 00 00	Retrofitting flyback diode for fan
----------------	------------------------------------

Labor Operation

+00 60 882	Retrofit free-wheeling diode for fan	6 FRU
------------	--------------------------------------	-------

FRUs includes all repair procedures to complete the task with allowance for necessary ancillary tasks (e.g., visual inspection, lubrication, cleaning parts etc.) and administrative tasks.

QUESTIONS REGARDING THIS BULLETIN

Technical inquiries	Contact the BMW Technical Support Group via TSARA
Warranty inquiries	Submit an IDS ticket to the Warranty Department
Parts inquiries	Submit an IDS ticket to the Motorrad Parts Department