

**SIB 46 08 07**

Center-stand stop bent out of shape - Bulletin 46 005 07 (016)

2021-11-30

This Service Information Bulletin replaces SI 46 005 07 (016) **dated April 2007**.

The contents of this bulletin have not changed; bulletin numbering was updated.

MODEL

This document applies to the following Motorrad AG models: n/a

This document applies to the following Motorrad model descriptions: n/a

This document applies to the following Motorrad series: n/a

SITUATION

This document is applies to the following categories: Maintenance and General Information

Supporting Materials

[picture_as_pdf 46 005 07 \(016\) - Center-stand stop bent out of shape.pdf](#)

Dealer Operation/ General Manager	Sales- Motorcycles	Sales - Used Motorcycles	Business Manager (F&I)	Service	Parts & Accessories	Administration
Date: April 2007 Bulletin # 46 005 07 (016)		Source: 02/2007 BMW Motorrad USA Service and Technical				



BMW Motorrad USA

Service Information Bulletin

Subject: Center-stand stop bent out of shape

Model: K 1200 GT (K44)

Details: Manufacturing tolerances between the center stand and the main frame can result in excessive endplay of the center-stand pivot mount.

This results in the center-stand stop (1) not coming into correct contact with the stop plates (2) on the frame or contacting only one of the plates on either the left or right. If this occurs the load is applied incorrectly and can bend the plate or plates out of shape.

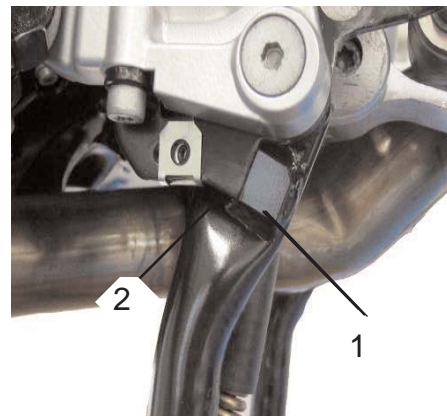

If this happens more force has to be exerted to lift the motorcycle onto the stand.

Motorcycles Affected: In order to determine if a specific motorcycle is affected by this Technical Campaign, it will be necessary to verify all motorcycle VINs through a DCS Vehicle History Check. Based on the response of the system, either proceed with the repair or take no further action.

The following VIN range is for informational purposes only:

ZN45000 - ZN46284

Series Solution: Both stops on the center stand are now 2 mm wider, to ensure that the load is applied equally to both stops. The stop plates will no longer bend out of shape.

Aftersales Solution: **Step 1: Checking center-stand stops**

Check operation and positional tolerances of the centre stand as follows:

- Lift the motorcycle, with the centre stand extended, onto the rear-wheel stand (36 3 980); check that the motorcycle is secure and cannot fall.
- The center stand is extended, but is clear of the ground. Begin by pulling the centre stand **as far as it will go to the left**.
- Visually inspect the assembly from both sides.
- **On each side, the stop of the center stand (1) must project further than the stop plate (2).**

- Now pull the center stand **as far as it will go to the right.**
- Again, visually inspect the assembly from both sides.
- **On each side, the stop of the center stand (1) must project further than the stop plate (2).**

If after checking both sides, the center stand tolerances are correct it is not necessary to replace the center stand.

If it is found that the center stand tolerances are not correct on either side it will be necessary to replace the center stand.

Refer to the latest edition of the K4x RepROM for the procedures on how to replace the center stand.

Note: It is highly recommended that the following special tools are used to remove and install the center stand springs. This tool makes removing and installing the springs much easier.

83 30 0 417 792 - Spring expander set includes the following:

- 83 30 0 417 793 - Expander body
- 83 30 0 417 794 - F 650/ F800 adapter
- 83 30 0 417 795 - R 1200 GS adapter
- 83 30 0 417 796 - R 1200 RT / ST adapter

83 30 0 009 916 - adapter for K 1200 S/R/GT models.(order separately)

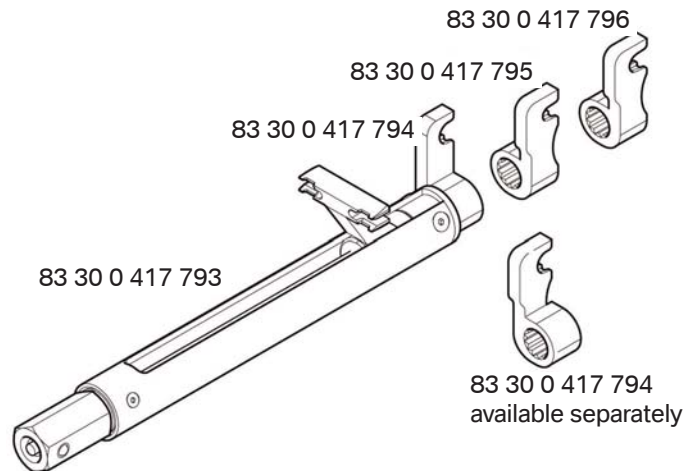

Warranty: Covered under the terms of the BMW New Motorcycle Limited Warranty.

Warranty Information: Reimbursement for this Technical Campaign will be through normal claim entry utilizing the following information:

Defect code:	00 46 32 00 00	Center-stand stop bent out of shape
FRU Code:	00 60 154	Checking center-stand stops
FRU:	2 FRUs	

FRU Code:	00 60 638	Replacing centre stand with stop
FRU:	4 FRUs	

Part Information:	46 52 7 709 193	Center stand
	46 52 7 691 635	Stop, left
	46 52 7 691 632	Stop, right

Contact: Respective Field Service Engineers