

Emissions Service Action

Code: 26P2



Subject	Catalytic Converter																													
Release Date	December 14, 2021																													
Affected Vehicles	<table border="1"> <thead> <tr> <th>Country</th> <th>Beginning Model Year</th> <th>Ending Model Year</th> <th>Vehicle</th> <th>Vehicle Count</th> </tr> </thead> <tbody> <tr> <td>USA</td> <td>2019</td> <td>2019</td> <td>A8</td> <td>4,182</td> </tr> <tr> <td>USA</td> <td>2019</td> <td>2019</td> <td>Q8</td> <td>11,238</td> </tr> <tr> <td>CAN</td> <td>2019</td> <td>2019</td> <td>A8</td> <td>266</td> </tr> <tr> <td>CAN</td> <td>2019</td> <td>2019</td> <td>Q8</td> <td>2,270</td> </tr> </tbody> </table>					Country	Beginning Model Year	Ending Model Year	Vehicle	Vehicle Count	USA	2019	2019	A8	4,182	USA	2019	2019	Q8	11,238	CAN	2019	2019	A8	266	CAN	2019	2019	Q8	2,270
Country	Beginning Model Year	Ending Model Year	Vehicle	Vehicle Count																										
USA	2019	2019	A8	4,182																										
USA	2019	2019	Q8	11,238																										
CAN	2019	2019	A8	266																										
CAN	2019	2019	Q8	2,270																										
	<p>Check Campaigns/Actions screen in Elsa on the day of repair to verify that a VIN qualifies for repair under this action. Elsa is the <u>only</u> valid campaign inquiry & verification source.</p> <ul style="list-style-type: none"> ✓ Campaign status must show "open." ✓ If Elsa shows other open action(s), inform your customer so that the work can also be completed at the same time the vehicle is in the workshop for this campaign. 																													
Problem Description	A small number of vehicles were manufactured with incorrect catalytic converters. This issue does not have any impact on vehicle tailpipe emissions.																													
Corrective Action	To ensure continued emissions compliance, Audi will proactively inspect and replace the catalytic converters on affected vehicles.																													
Code Visibility	On or about December 14, 2021 the campaign code will be applied to affected vehicles.																													
Owner Notification	Owner notification will take place in December 2021. Owner letter examples are included in this bulletin for your reference.																													
Emissions Campaigns Requirements (CALIFORNIA ONLY)	The California Air Resources Board and the Department of Motor Vehicles (DMV) require emissions-related campaigns to be completed prior to vehicle registration renewal. When campaign work is done you must provide the owner with a signed "Vehicle Emission Recall – Proof of Correction" certificate (RC EMISCAVWAW). Order certificates online via the Compliance Label Ordering portal at www.accessaudi.com .																													
Additional Information	<p>Please alert everyone in your dealership about this action, including Sales, Service, Parts and Accounting personnel. Contact Warranty if you have any questions.</p> <p>Dealers must ensure that every affected inventory vehicle has this campaign completed <u>before delivery to consumers</u>.</p> <p>Fill out and affix Campaign Completion Label (CAMP 010 000) after work is complete. <i>Labels can be ordered at no cost via the Compliance Label Ordering portal at www.accessaudi.com.</i></p>																													

Parts Information (if necessary)

CRITICAL PARTS INFORMATION



STOP!

Do not order the following parts unless they are absolutely needed! The expected need for the following parts is less than 0.1%. Ordering parts unnecessarily will cause delays.

Parts Control Type: VIN to Order	If parts are needed to support a vehicle repair: <ul style="list-style-type: none"> • US Dealers - use AVA • CAN Dealers - contact the Parts Specialists via phone (800-767-6552), email (VWoAPartsSpecialists@vw.com), or chat/text with the VIN to order
---	--

Parts Control Type: Free Order	Parts will be managed by Free Order
---	-------------------------------------

Initial Allocation: NO	There will be no parts allocation. Please reference the Repair Projection Tool (below) to view your potential VIN population.
---	---

Repair Projection Tool: (right click to open)	
--	--

Model	Quantity	Part Number	P.O.C. Part Description	Ordering Method (see description above)
A8	1	4N0-254-250-QX	CATALYST	VIN to Order
	1	8W0-253-725-A	CLAMP	Free Order
	1	8W0-253-115-G	GASKET	Free Order
	2	8K0-253-115-K	GASKET	Free Order
	6	N -911-308-01	NUT	Free Order
Q8	1	4M0-254-202-BX	CATALYST	VIN to Order
	1	8W0-253-725-A	CLAMP	Free Order
	1	8W0-253-115-G	GASKET	Free Order
	1	8E0-253-115-C	GASKET	Free Order
	3	N -911-308-01	NUT	Free Order

NOTE

The specified part numbers reflect the status at the start of this action. Interim updates made in ETKA can cause a listed part number to become unavailable. In this case, the new part number specified in ETKA should be used.

Claim Entry Instructions

The labor times listed here may differ from the labor operations and labor times listed in ELSA.

After campaign has been completed, enter claim as soon as possible to help prevent work from being duplicated elsewhere. Attach the Elsa screen print showing action open on the day of repair to the repair order.

If customer refused campaign work:

- ✓ U.S. dealers: Submit the request through Audi Warranty Online under the Campaigns/Update option.
- ✓ Canada dealers: Upload the repair order [signed by customer] to Audi WIN/Operations/Campaign Closure.

Service Number	26P2		
Damage Code	0099		
Parts Vendor Code	002		
Claim Type	Sold vehicle: 7 10 Unsold vehicle: 7 90		
Causal Indicator	Mark labor as causal part if catalyst is NOT replaced Mark CATALYST* as causal part if catalyst IS replaced		
Vehicle Wash/Loaner	Do not claim wash/loaner under this action		
Criteria I.D.	01		
MODEL	A8		
	Inspect catalyst part numbers, correct catalyst is installed, no replace is needed.		
	LABOR		
	Labor Op	Time Units	Description
	0183 00 99	25	Inspect catalyst part number, no replacement needed
-OR-	Inspect catalyst part numbers, incorrect catalyst is installed, replacement is required.		
	LABOR		
	Labor Op	Time Units	Description
	2673 55 99	150	Replace catalyst
	PARTS		
	Quantity	Part Number	Description
	1.00	4N0254250QX	CATALYST*
	1.00	8W0253725A	CLIP
	1.00	8W0253115G	GASKET
	2.00	8K0253115K	GASKET
	6.00	N 91130801	SHOULDERED HEX NUT, SELF-LOCKING

Continued on next page

MODEL	Q8		
	Inspect catalyst part numbers, correct catalyst is installed, no replacement is needed.		
	LABOR		
	Labor Op	Time Units	Description
	0183 00 99	45	Inspect catalyst part number, no replacement needed
-OR-	Inspect catalyst part numbers, incorrect catalyst is installed, replacement is required.		
	LABOR		
	Labor Op	Time Units	Description
	2673 56 99	110	Replace catalyst
	PARTS		
	Quantity	Part Number	Description
	1.00	4M0254202BX	CATALYST*
	1.00	8W0253725A	CLIP
	1.00	8W0253115G	GASKET
	1.00	8E0253115C	GASKET
	3.00	N 91130801	SHOULDERED HEX NUT, SELF-LOCKING

Customer Letter Example (USA)

<MONTH YEAR>
<CUSTOMER NAME>
<CUSTOMER ADDRESS>
<CUSTOMER CITY STATE ZIPCODE>

This notice applies to your vehicle: <MODEL YEAR> <BRAND> <CARLINE>, <VIN>

Subject: Emissions Service Action 26P2 – Catalytic Converters

Dear Audi Owner,

In cooperation with the United States Environmental Protection Agency and the California Air Resources Board, we are informing you of our decision to conduct an emissions service action on certain 2019 model year Audi vehicles. Our records show that you are the owner of a vehicle affected by this action.

- What is the issue?** A small number of vehicles were manufactured with incorrect catalytic converters. This issue does not have any impact on vehicle tailpipe emissions.
- What will we do?** To ensure continued emissions compliance, your authorized Audi dealer will proactively inspect and replace the catalytic converters, if necessary, on affected vehicles. The inspection will take about an hour to complete and will be performed for you free of charge. Please keep in mind that your dealer may need additional time for the preparation of the repair, as well as to accommodate their daily workshop schedule.
- What should you do?** In order to limit any possible inconvenience, please contact your authorized Audi dealer as soon as possible to schedule this service. For your convenience, you can also visit www.audiusa.com and click on the "Find a Dealer" link to locate a dealer near you and schedule this service.
- Lease vehicles and address changes** If you are the lessor and registered owner of the vehicle identified in this action, please forward this letter immediately via first-class mail to the lessee within ten (10) days of receipt. If you have changed your address or sold the vehicle, please fill out the enclosed prepaid Owner Reply card and mail it to us so we can update our records.
- Important information for California Vehicle Owners – California Regulations** California regulations require that this campaign be completed prior to the time you renew your vehicle registration. Therefore, **please make sure that this campaign is completed prior to the renewal of your vehicle registration**, and that you furnish proof of completion to the Department of Motor Vehicles (DMV) in the form of a copy of the dealer's repair order, including a signed "Proof of Correction" certificate. You obtain this from your dealer after the campaign has been completed. Please retain the signed "Proof of Correction Certificate" with your vehicle records. DO NOT MAIL THIS FORM to the DMV, unless requested.
- Can we assist you further?** If your authorized Audi dealer fails or is unable to complete this work free of charge within a reasonable time, please contact Audi Customer Experience at 1-800-253-2834 or via our "Contact Us" page at www.audiusa.com.
- Checking your vehicle for open Recalls and Service Campaigns** To check your vehicle's eligibility for repair under this or any other recall/service campaign, please visit the **Recall/Service Campaign Lookup** tool at www.audiusa.com and enter your Vehicle Identification Number (VIN).

We apologize for any inconvenience this matter may cause; however we are taking this action to help ensure your vehicle continues to meet and exceed your expectations.

Sincerely,

Audi Customer Protection

Customer Letter Example (Canada)

<MONTH YEAR>

<CUSTOMER NAME>

<CUSTOMER ADDRESS>

<CUSTOMER CITY STATE ZIPCODE>

This notice applies to your vehicle: <MODEL YEAR> <BRAND> <CARLINE>, <VIN>

Subject: Emissions Service Action 26P2 – Catalytic Converters

Dear Audi Owner,

This notice is sent to you in accordance with the requirements of the *Canadian Environmental Protection Act, 1999*. Audi has determined that a defect, which relates to a prescribed emission standard, exists in certain 2019 model year Audi vehicles. Our records show that you are the owner of a vehicle affected by this action.

What is the issue? A small number of vehicles were manufactured with incorrect catalytic converters. This issue does not have any impact on vehicle tailpipe emissions.

What will we do? To ensure continued emissions compliance, your authorized Audi dealer will proactively inspect and replace the catalytic converters, if necessary, on affected vehicles. The inspection will take about an hour to complete and will be performed for you free of charge. Please keep in mind that your dealer may need additional time for the preparation of the repair, as well as to accommodate their daily workshop schedule.

What should you do? In order to limit any possible inconvenience, please contact your authorized Audi dealer as soon as possible to schedule this service. On or about December 14, 2021 the necessary repair instructions and parts will be available to your authorized Audi dealer.

Lease vehicles and address changes If you are the lessor and registered owner of the vehicle identified in this action, please forward this letter immediately via first-class mail to the lessee within ten (10) days of receipt. If you have changed your address or sold the vehicle, please fill out the enclosed prepaid Owner Reply card and mail it to us so we can update our records.

Can we assist you further? If your authorized Audi dealer fails or is unable to complete this work free of charge within a reasonable time, please contact Audi Customer Relations Monday through Friday from 8AM to 8PM EST at 1-800-822-2834 or via our "Contact Audi Canada" page at www.audi.ca.

We apologize for any inconvenience this matter may cause; however we are taking this action to help ensure your vehicle continues to meet and exceed your expectations.

Sincerely,

Audi Customer Protection

Repair Overview



- Inspect catalyst part numbers and replace, if necessary.

! NOTE

- These repair instructions may differ from the labor operations and labor times listed in ELSA.
- Damages resulting from improper repair or failure to follow these work instructions are the dealer's responsibility and are not eligible for reimbursement under this action.
- This procedure must be read in its entirety prior to performing the repair.
- Due to variations in vehicle equipment and options, the steps/illustrations in this work procedure may not identically match all affected vehicles.
- Diagnosis and repair of pre-existing conditions in the vehicle are not covered under this action.
- When working during extreme temperatures, it is recommended that the vehicle be allowed to acclimate inside the shop to avoid temperature-related component damage/breakage.

Repair Instruction

Section A - Check for Previous Repair

Applicable criteria ID(s)	Campaign/Action Status
01 ← 2	Open ← 1

EXAMPLE

Campaign/Action	Start	Designation
← 3 →	2015-11-10	W-SERV_ACT -
	2018-12-13	RECALL -
	2017-05-16	A-RECALL -

EXAMPLE

- Enter the VIN in Elsa and proceed to the “Campaign/Action” screen.

TIP

On the date of repair, print this screen and keep a copy with the repair order.

- Confirm the Campaign/Action is open <arrow 1>. If the status is closed, no further work is required.
- Note the Applicable Criteria ID <arrow 2> for use in determining the correct work to be done and corresponding parts associated.

CRITICAL REPAIR STEP

 **STOP!** 

If multiple software update Campaign/Actions are open, they must be performed in order of the Start date <arrow 3>. The oldest should be performed first.

- **All Safety Recalls must be completed prior to completing this campaign.**

A8 Models – Proceed to Section B.

Q8 Models – Proceed to Section C.

Section B – Repair Instructions for A8 Models

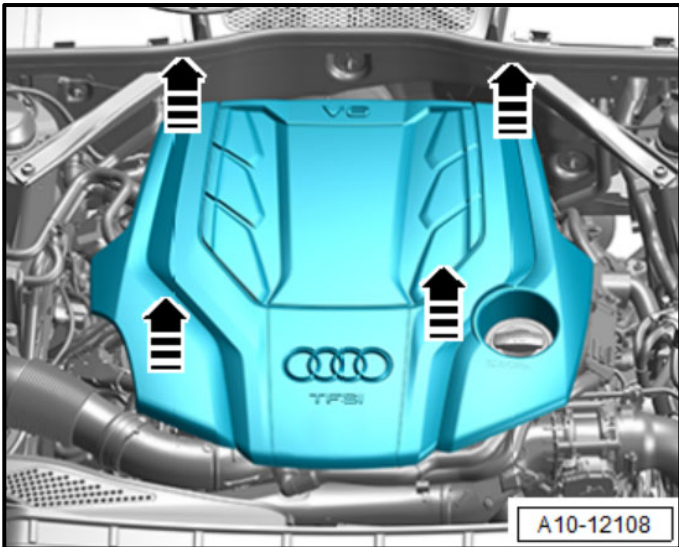

Remove engine cover:

- Carefully pull the engine cover off the retaining pins one after the other in direction of <arrows>. Do not pull sharply on the engine cover or pull it to one side.

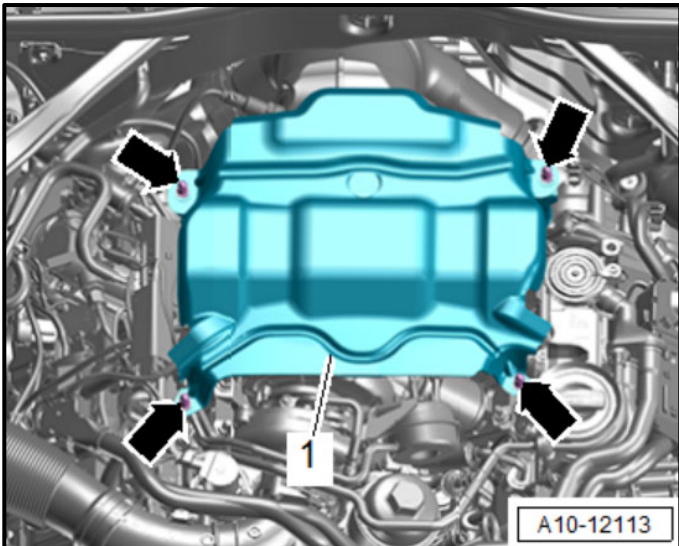

Remove heat shield:

- Remove the ball pins and bolts <arrows> and then remove the heat shield <1>.

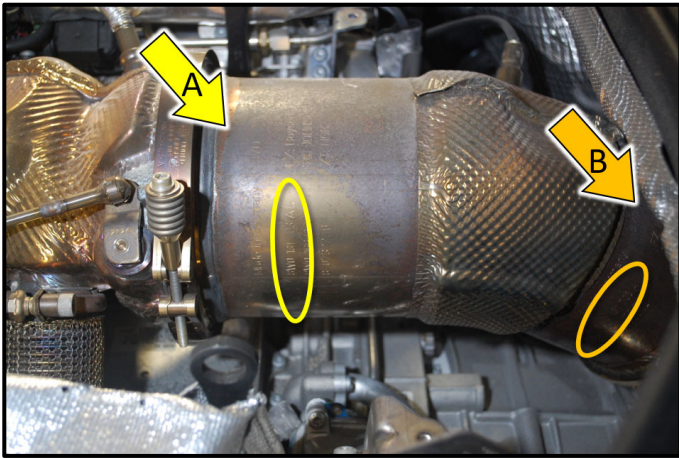

Inspect catalyst part numbers:

CAUTION

There is a risk of burn injuries due to a hot exhaust system.
Possible to burn hands and other parts of the body.

Section A

Correct Part Number 8W0-131-703-AL

Incorrect Part Number 8W0-131-703-T

Section B

Correct Part Number 8W0-131-703-AM

Incorrect Part Number 8W0-131-703-AA

- Check the part numbers <circles> on each section <arrows A and B> of the catalyst.
- If the part number is incorrect on either section of the catalyst:
 - The catalyst must be replaced.
- If the part numbers are correct on both sections of the catalyst:
 - Reinstall the heat shield and engine cover.
 - Proceed to Section D.

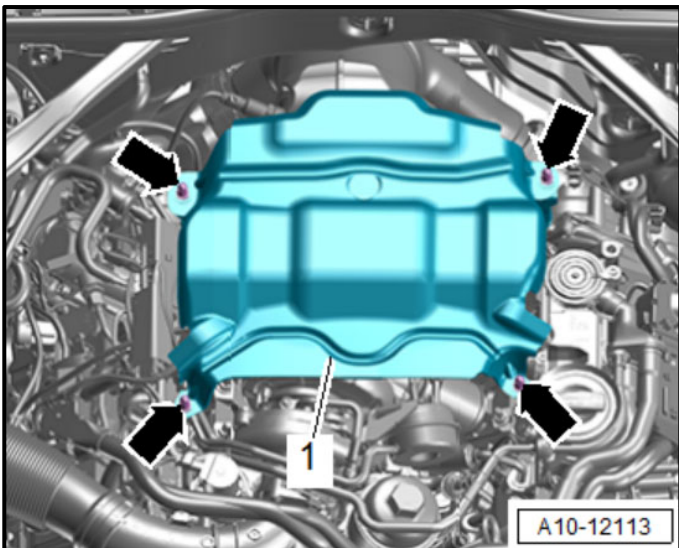

Reinstalling heat shield and engine cover:

WARNING

Fire hazard and risk of damage due to a missing heat shield/engine cover.

Never close the hood if the heat shield and engine cover are not installed.

Never start the engine or move the vehicle if the heat shield/engine cover are missing and the hood is closed.

- Installation is the reverse order of removal.
- Torque heat shield fasteners to 5 Nm + 45°.

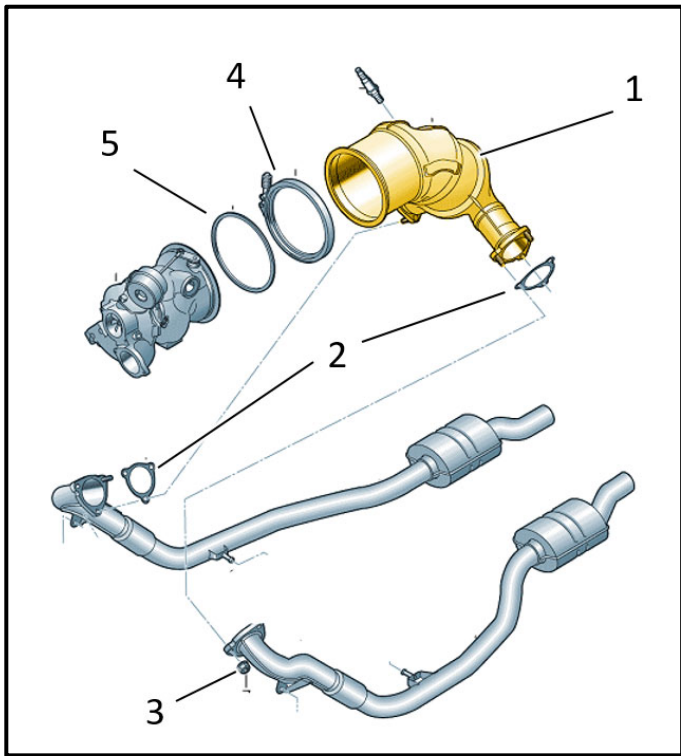

Replacing catalyst (if necessary):

- Replace catalyst ONLY if the part numbers were incorrect.
- See ELSA Repair Manual: *Repair manual > Engine > 6-Cylinder Direct Injection 3.0L 4V TFSI Engine EA839 > 26 Exhaust System, Emission Controls > Emissions Control System > Catalytic Converter, Removing and Installing*
- Torque nuts <3> to 25 Nm.
- Torque clamp <4> to 7 Nm.
- Torque oxygen sensor to 55 Nm.
- Torque subframe heat shield bolts to 9 Nm.

After replacing catalyst - Proceed to Section D

Pos.	Part Number	Description
1	4N0-254-250-QX	Catalyst
2	8K0-253-115-K	Gasket (x2)
3	N -911-308-01	Nut (x6)
4	8W0-253-725-A	Clamp
5	8W0-253-115-G	Gasket

Section C – Repair Instructions for Q8 Models

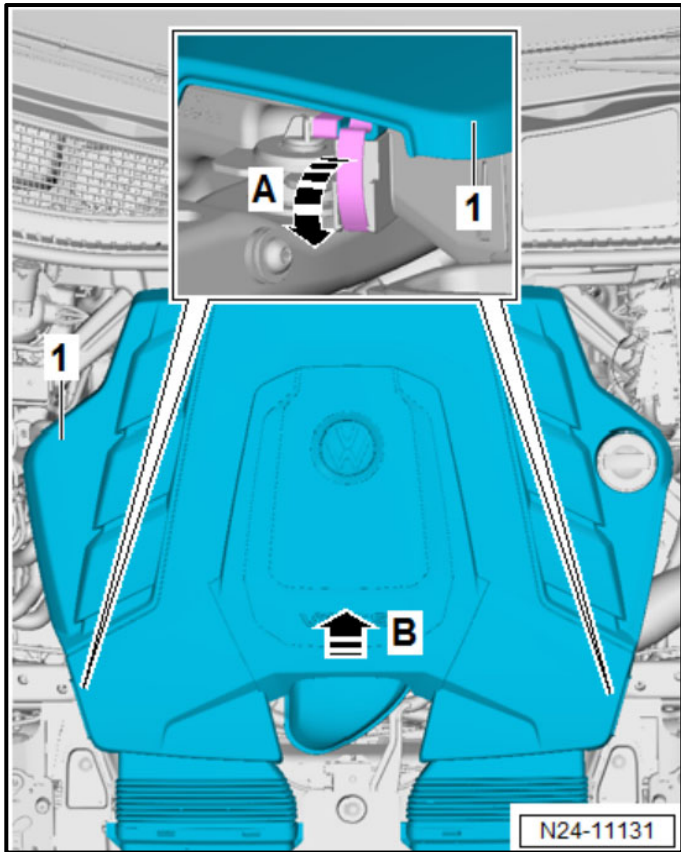

Remove air filter housing:

- Open the left and right clamp in direction of <arrow A>.
- Remove the air filter upper section <1> in the center upward from the ball pins in direction of <arrow B> and disengage from the air filter lower section.
- Remove the air filter upper section.

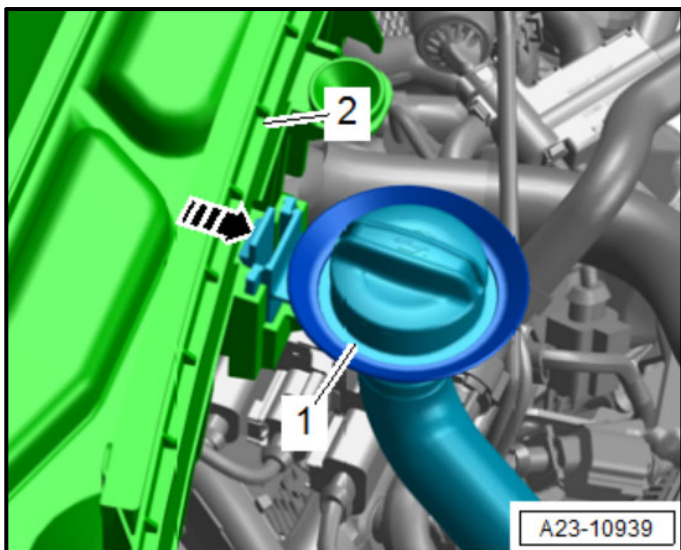

- Release the retainer in direction of <arrow> and oil filler tube <1> upward from the air filter lower section <2>.

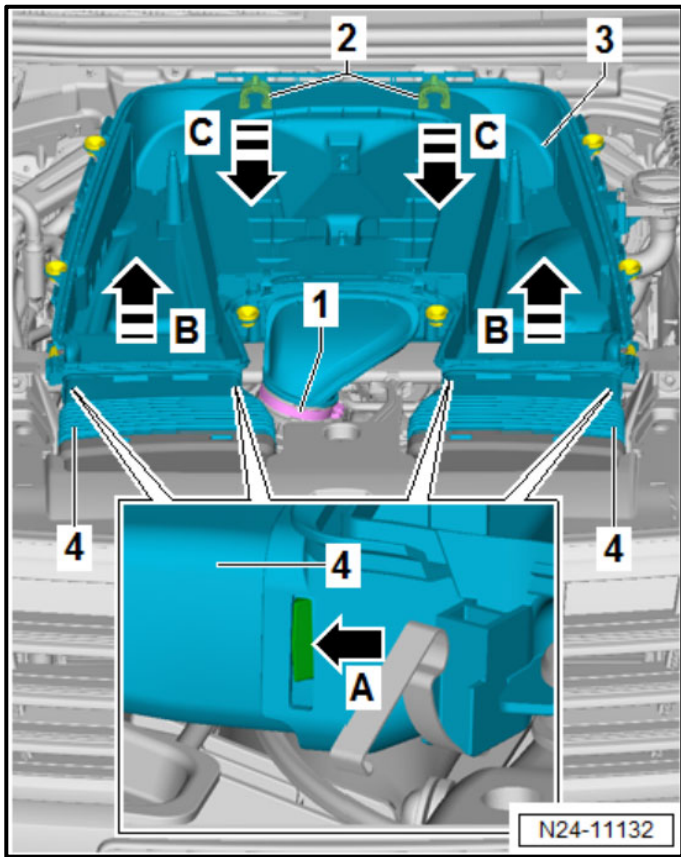

- Release the retainers <arrow A> and remove the air ducts <4> from the air filter lower section <3>.
- Loosen the screw-type clamp <1>.
- Remove the front air filter lower section upward from the ball pins in direction of <B arrows>.
- Remove the rear mounts <2> forward in direction of <C arrows>.

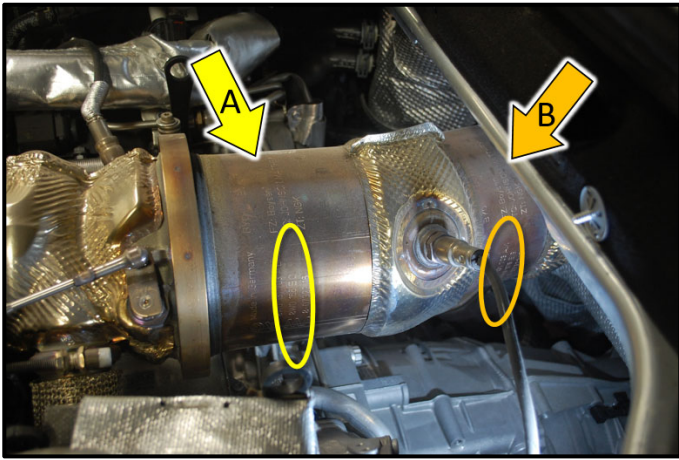

Inspect catalyst part numbers:

⚠ CAUTION

There is a risk of burn injuries due to a hot exhaust system.

Possible to burn hands and other parts of the body.

Section A

Correct Part Number	8W0-131-703-AL
----------------------------	-----------------------

Incorrect Part Number	8W0-131-703-T
------------------------------	----------------------

Section B

Correct Part Number	8W0-131-703-AM
----------------------------	-----------------------

Incorrect Part Number	8W0-131-703-AA
------------------------------	-----------------------

- Check the part numbers <circles> on each section <arrows A and B> of the catalyst.
- If the part number is incorrect on either section of the catalyst:
 - The catalyst must be replaced.
- If the part numbers are correct on both sections of the catalyst:
 - Reinstall the air filter housing.
 - Proceed to Section D.

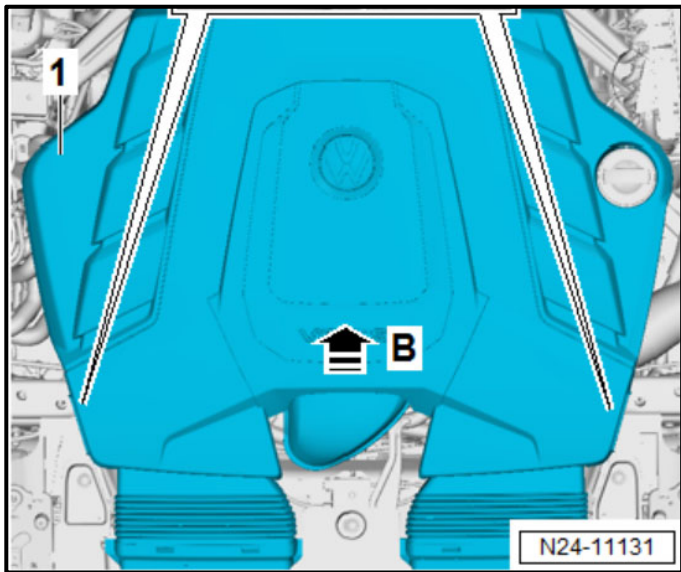

Reinstalling air filter housing:

⚠ WARNING

Fire hazard and risk of damage due to a missing heat shield/engine cover.

Never close the hood if the engine cover is not installed.

Never start the engine or move the vehicle if the heat shield/engine cover are missing and the hood is closed.

ⓘ NOTE

The air filter housing must always be clean.

To avoid malfunctions, critical components, such as the mass airflow sensor, air duct pipes, etc., must be covered with a clean cloth when blowing out the air filter housing with compressed air.

The hose connections as well as air duct pipes and hoses must be free of oil and grease before installing.

Use a silicone-free lubricant to mount the air duct hoses.

- Installation is the reverse order of removal.
- Check the air duct pipe (intake air side) for salt residue, dirt and leaves.
- Check the air duct from the lock carrier to the air filter housing for dirt and leaves.
- Do not hit the air filter upper section with a fist or a tool to avoid damaging it.
- Insert the air filter upper section into the back of the air filter lower section and use both hands to push it onto the retaining pins.

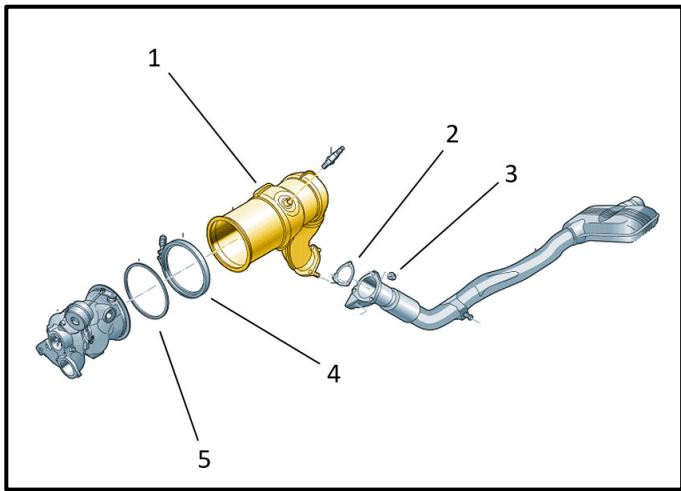

Replacing catalyst (if necessary):

- Replace catalyst ONLY if the part numbers were incorrect.
- See ELSA Repair Manual: *Repair manual > Engine > 6-Cylinder Direct Injection 3.0L 4V TFSI Engine EA839 > 26 Exhaust System, Emission Controls > Emissions Control System > Catalytic Converter, Removing and Installing*
- Torque nuts <3> to 25 Nm.
- Torque clamp <4> to 7 Nm.
- Torque oxygen sensor to 55 Nm.

Pos.	Part Number	Description
1	4M0-254-202-BX	Catalyst
2	8E0-253-115-C	Gasket
3	N -911-308-01	Nut (x3)
4	8W0-253-725-A	Clamp
5	8W0-253-115-G	Gasket

After replacing catalyst - Proceed to Section D

Section D – Campaign Completion Stamp

I certify that this campaign has been performed in strict accordance with the applicable Audi repair procedure.

SAGA Code: _____

Technician: _____

Date: _____

Item#: AUD4927ENG

-OR-

Je certifie que cette campagne de rappel a été exécutée suivant les strictes directives de réparation d'Audi

Code de SAGA: _____

Technicien: _____

Date: _____

Item # AUD4927FRE

- Once the campaign has been completed, the technician should stamp the repair order.
- Stamps are available for ordering through the Compliance Label Ordering Portal.
- **Proceed to Section E**

Section E – Campaign Completion Label

Install Campaign Completion Label

- Fill out and affix Campaign Completion Label, part number CAMP 010 000, next to the vehicle emission control information label.

TIP

Ensure Campaign Completion Label does not cover any existing label(s).

Proceed to Section F

Section F - Parts Return/Disposal

Properly store (retain), destroy or dispose of removed parts in accordance with all state/province and local requirements, unless otherwise indicated and/or requested through the Warranty Parts Portal (WPP) for U.S. and the Part Destruction and Core Disposition Report for Canada.

Proceed to Section G (California only).

Section G – California Only Requirements

CALIFORNIA ONLY Requirements for Emissions Campaigns Having Customer Notification

The California Air Resources Board and the Department of Motor Vehicles (DMV) require emissions-related campaigns to be completed prior to vehicle registration renewal. **When campaign work is done you must provide the owner with a signed “Vehicle Emission Recall – Proof of Correction” certificate (RC EMIS_CAL VW).** Certificates can be ordered at no cost online via the Compliance Label Ordering portal at www.accessaudi.com.

TIP

Ensure owners are aware of the importance of retaining the completed certificate for their records. It should be mailed to the California DMV only upon request.