



Countries: CANADA, UNITED STATES, MEXICO Document ID: IK0700115
 Availability: ISIS, Bus ISIS, FleetISIS, IsSIR Revision: 14
 Major System: EXHAUST Created: 8/26/2021
 Current Language: English Last Modified: 11/18/2021
 Other Languages: [Français](#) Author: William Knoth
 Viewed: 8502

[Less Info](#)

Hide Details

Coding Information

Copy Link 	Copy Relative Link 	Bookmark View My Bookmarks	Add to Favorites 	Print 	Provide Feedback 	Helpful 31	Not Helpful 1
----------------------	-------------------------------	--	-----------------------------	------------------	-----------------------------	--------------------------	-----------------------------

Title: QLS Emergency Calibration

Applies To: 2016 and Newer B6.7, X15 and L9, and all A26

CHANGE LOG

Please refer to the change log text box below for recent changes to this article:

11/18/2021 - Added ISB6.7 MY16
 11/09/2021 - Added ISX15 MY16 and L9 MY16
 11/01/2021 - Removed ISX15 MY16 due to software issue - Cummins is investigating
 10/22/2021 - Added engine model year 2016 ISX engines, updated FAQ answers about the TRP
 10/14/2021 - Add info about window cling

DESCRIPTION

This document is intended for information purposes only to inform the user about an emergency calibration release that has been approved by the EPA and CARB to help provide relief from the global supply shortage of electrical components.

The purpose of this calibration is to provide a short term calibration strategy that will allow vehicle operation with a failed DEF head unit / Quality Level Sensor (QLS). Any vehicle that receives the emergency calibration will eventually be required to have it rolled back to a production level calibration and a new QLS installed once parts become available, this will be managed through future communication once the parts supply has stabilized and should NOT be performed until this future communication is released.

Any vehicle that receives this calibration will continue to require a QLS unit to be installed and DEF fluid to operate. The changes are only to the strategies for the failure detection methods (outlined below under calibration identification section). It is also required that the customer letter either linked in the Cummins TRP or the Navistar reference sheet [4328818R1](#) be printed and placed in the vehicle prior to the vehicle going back into service. It is also strongly recommended that the driver be informed to the changes in the DEF gauge operation as outlined in the required documentation.

SYMPTOM(s)

Diagnostic Trouble Code(s) & Dashboard Indicator Light(s):

Cummins DTC/Light	Description
0-SPN3364-09 (Cummins Fault 3868)	Aftertreatment Diesel Exhaust Quality - Abnormal Update Rate
0-SPN3031-09 (Cummins Fault 4572)	Aftertreatment Diesel Exhaust Tank Temperature - Abnormal Update Rate
0-SPN1761-09 (Cummins Fault 4677)	Aftertreatment Diesel Exhaust Fluid Tank Volume - Abnormal Update Rate

Navistar DTC/Light	Description
0-SPN3516-19	Aftertreatment Diesel Exhaust Concentration - Received network data error
0-SPN1761-19	Aftertreatment Diesel Exhaust Fluid Tank Volume - Received network data error



WARNING:

The EPA and CARB has only granted Navistar limited use of the QLS emergency calibration as it applies to the faults listed in the table above and diagnostic steps outlined in this article. The use of this calibration in any other circumstances could be considered tampering of an emission level component.

CALIBRATION IDENTIFICATION

Calibration Cross Reference Table:

Engine	Production Calibration	QLS Emergency Calibration
A26	xxxxSUxB	xxxxSUxZ

*For Cummins powered vehicles refer to [TSB210187](#)

With a Production Calibration:

When the ECM detects a fault associated with the SCR system tampering logic the engine warning light will be turned on. After one hour of operation with the fault active the vehicle will enter a 25% de-rate. After 5 hours of operation with the fault active the vehicle will enter a 5mph de-rate. See figure #2 for the de-rate strategy. In some cases, with the SCR inducement faults active, an SCR reset will be required with the service tool.

With the QLS Emergency Calibration:

The ECM may still log the QLS communication faults listed above, however it will not have any driver notification through a MIL or a de-rate reaction. The ECM will still follow the original de-rate strategy for all other faults, including all other QLS faults (see figure #2). Therefore, this calibration is not approved for any vehicle with faults other than the ones listed above.

The function of the different DEF head unit sensors are being handled by other means.

- DEF Quality will be monitored through SCR conversion efficiency
- DEF Tank thaw strategy will be through the ambient air temp
- DEF Tank empty will be determined by the ability of the DEF system to prime
- DEF Tank level will NOT function

With the DEF gauge not functioning the DEF Tank Miles to Empty will not read correctly or read N/A. It is strongly recommended that the vehicle be filled with DEF at every full stop to ensure the tank stays topped off.

Depending on the DLB parameter setting the cluster may produce an audible alarm for low DEF level. The default setting is set to "No Alarm" for all vehicles as built. This should only be checked if there is a complaint or it is known to have been changed. If the parameter has been changed it will need to be returned to the original setting of "No Alarm". See figure #11 in the DEF cluster alarm section below.

CAUTION:

The DEF tank level gauge will NOT function with the QLS emergency calibration. It may show incorrect or empty at all times.

Note:

With the QLS emergency calibration the QLS communication faults will still be visible in Insite. However, they will not be broadcasted to displayed in the cluster or in health reports. With the QLS emergency calibration installed, these fault codes should be ignored.



Figure 1: DEF Level Gauge Reaction

Item 1: DEF Level Gauge

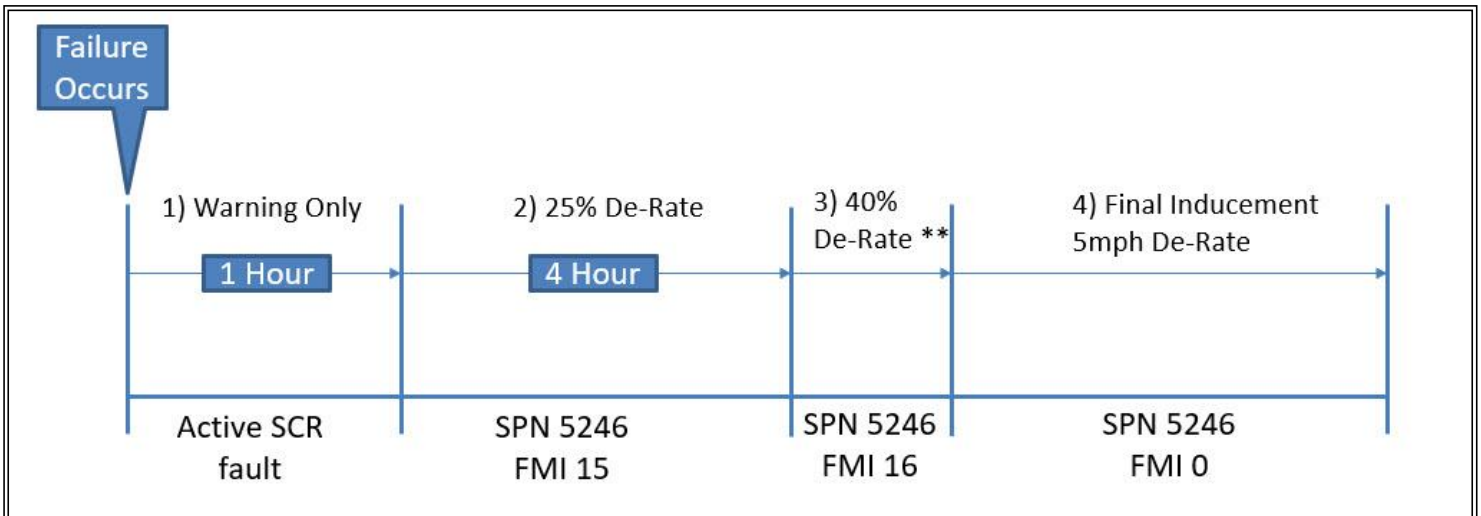

Figure 2: SCR System Tampering Inducement Faults

Item 1: For the first hour after a failure or tampering occurs there is a warning only, with no de-rate.

Item 2: Hour 1 to hour 5 there will be a 25% de-rate accompanied with fault code SPN 5246-15 AFT SCR operator inducement severity - Least severe.

Item 3: After 5 hours from initial awareness the vehicle will ramp to 40% de-rate and will search for the final inducement trigger accompanied with fault code SPN 5246-16 AFT SCR operator inducement severity - Moderately severe.

Item 4: Once final inducement is triggered the vehicle will ramp to a 5mph de-rate accompanied with fault code SPN 5246-0 AFT SCR operator inducement severity - Most severe.

Note: **The time between stage 3 and 4 will be determined based on the fault code and triggers. If repeated tampering occurs the time window between stages will be reduced.

SPECIAL TOOL(S) / SOFTWARE

Tool Description	Tool Number	Comments	Instructions
Cummins Insite Pro	Software	Fleet Count is required	Refer to Cummins TRP# T2489
NED (Navistar Engine Diagnostics)	NED.V7.6.81 or greater	Only allows the Calibration with fault code preset	Instructions are provided through popup messages in NEDs

CALIBRATION REQUIRED SERVICE PARTS INFORMATION

Part Number	Part Description	Quantity Needed	Notes
2644000R1	Heat Shrink Tubing 50mm	4	Or equivalent
306132C1	Tie Strap	1	Or equivalent

QLS SERVICE PARTS INFORMATION

NAVISTAR DEF HEAD UNIT PART NUMBERS				
3% (QLS) / Gen 1	3% with Cover (QLS) / Gen 1.1	1% with Cover (QLS) / Gen 2	1% with Cover (QLS) / REMAN	TANK SIZE
4097721C91	4254212C91	4163689C91	5012176R91	5 GAL
4097722C91	4254211C91	4157846C91	5012171R91	7 GAL
4097723C91	4254213C91	4163692c91	5012172R91	9.5 GAL
4097724C91	4254214C91	4163693C91	5012173R91	12 GAL
4097725C91	4254215C91	4163694C91	5012177R91	15 GAL
4097727C91 (ProStar)	4254216C91	4163695C91	5012174R91	15.5 GAL
				16 GAL
				23 GAL
4097728C91 (LT)	4254210C91	4140918C91	5012175R91	10.6GAL
				10.6GAL-LN
				15.9GAL
				15.9GAL-LN
25.2GAL				
3% / Gen 1 (FLS)	3% with Cover / Gen 1.1 (FLS)	1% with Cover / Gen 2 (FLS)	1% with cover / Reman (FLS)	TANK SIZE
4099715C91	4254200C91	4163697C91	5012178R91	7 GAL
4099716C91	4254201C91	4163698C91	5012179R91	9.5 GAL
4099717C91 (ProStar)	4254202C91	4163699C91	5012180R91	15.5 GAL
				16 GAL
				23 GAL
4099718C91 (LT)	4254203C91	4163700C91		10.6GAL
				10.6GAL-LN
				15.9GAL
				15.9GAL-LN
25.2GAL				

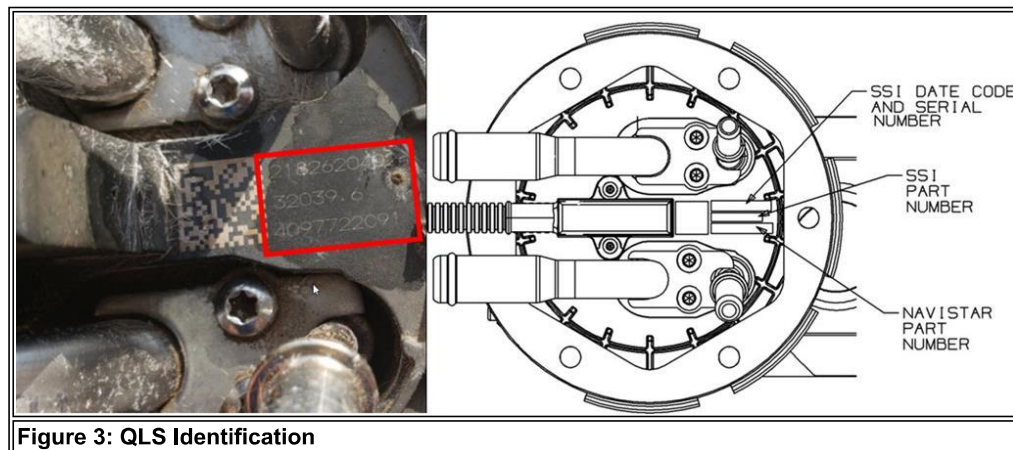

Figure 3: QLS Identification

DIAGNOSTIC STEP(s)



WARNING:

The EPA and CARB has only granted Navistar limited use of the QLS emergency calibration as it applies to the faults listed in the table above and diagnostic steps outlined in this article. The use of this calibration in any other circumstances could be considered tampering of an emission level component.

CAUTION:

This procedure is only intended to be used if a QLS is not available. If the QLS is available the part must be replaced, and the calibration can NOT be installed.

Step	Action	Decision
1	DIAGNOSTIC: Is the Vehicle marked with an AFC #21901 on the Navistar Service Portal or the ESN marked with the TRP #T2489 on Cummins Quickserve? If the vehicle is not marked with the TRP then there is not a calibration available at this time.	Yes. Go to step 2
		No. The vehicle will not qualify for the TRP or AFC. Follow standard diagnostics. This letter does not apply

Step	Action	Decision
2	DIAGNOSTIC: Does the vehicle present with only QLS communication faults listed in the fault code section of this article? Note: Other aftertreatment components share the same aftertreatment datalink as the QLS, when other AFT components log communication fault codes with the QLS it is likely not a QLS	Yes. Go to step 3
		No. The vehicle will not qualify for the TRP or AFC. Follow the diagnostics for the other fault codes present.

Step	Action	Decision
3	DIAGNOSTIC: Follow the circuit diagnostics outlined HERE . Note: The flow test of the DEFTHV should NOT be performed if the calibration is being installed.	Yes: Leave the QLS disconnected and proceed to step 4
	Did the circuit diagnostics lead back to this article and step 4?	No. The vehicle will not qualify for the TRP or AFC. Perform the necessary non QLS replacement repairs.

Step	Action	Decision
4	DIAGNOSTIC: Is there a replacement QLS available? Refer to the table above for QLS part numbers.	Yes. The vehicle will not qualify for the TRP or AFC. Please proceed with flow testing the DEFTHV and replacing the QLS.
		No. Refer to the repair steps listed below

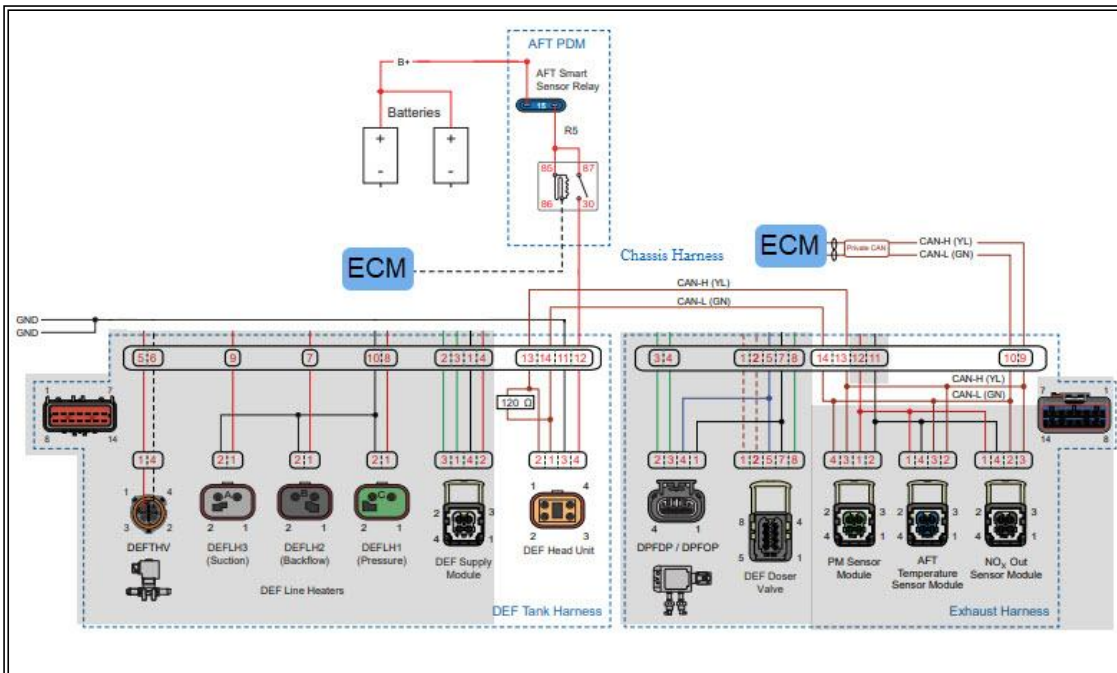

Figure 4: General QLS Wiring Diagram

Note: Refer to chassis circuit diagrams for detailed information

REPAIR STEP(s)

In some failure conditions the QLS sensor can produce faults intermittently, it is recommended that the sensor be removed electrically from the chassis harness to prevent this as it can lead to additional warnings and de-rate events. This can be performed simultaneously with the programming event. The intent of this procedure is to disconnect the sensor electrically and seal the harness to prevent moisture and corrosion in the chassis harness connector for when the QLS is replaced under future activity. The QLS must remain in the tank and connected to the DEF and coolant lines as they are still required for vehicle operation.

1. Ensure the QLS is disconnected from the chassis harness. **If the sensor is still connected it could result in shorting of the power circuit.**
2. Using wire cutters, cut the QLS pigtail harness as least four inches from the connector (Refer to figure #5). Once cut the pigtail can be moved to a bench for ease of installation.

Note: At no point is the QLS removed from the DEF tank during this procedure.

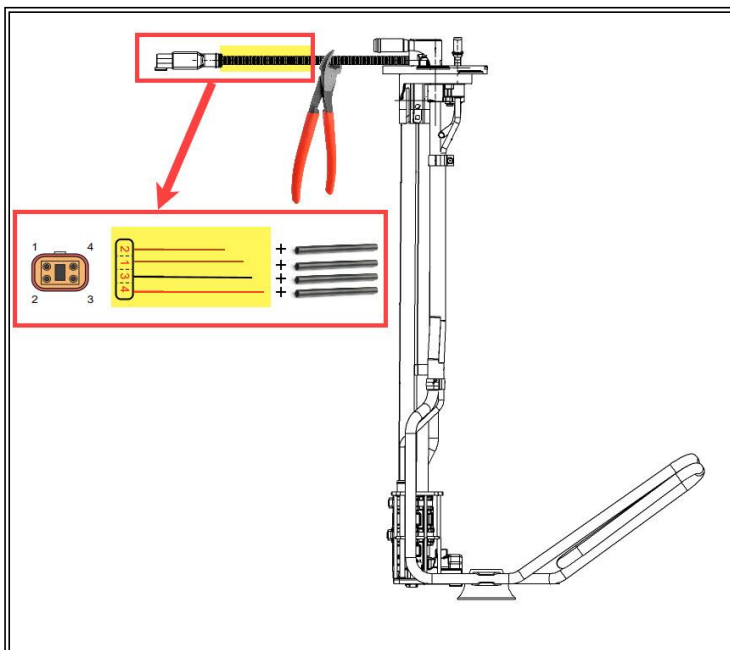

Figure 5: QLS Pigtail Modification

Item 1: QLS Pigtail

3. Refer to the below programming procedure for A26 or Cummins TRP# [T2489](#) and [TSB210187](#) and start the programming procedure on the vehicle
4. Remove the wire loom from the pigtail end.
5. Loop each wire and apply heat shrink tubing to each end of the wire (Refer to figure #6).

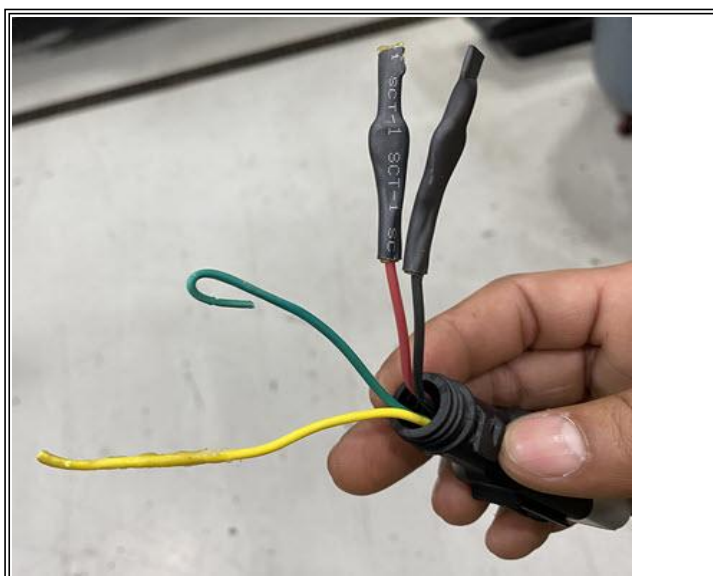

Figure 6: QLS Pigtail Wire Loop

6. Use a heat gun to apply heat to each piece of heat shrink tubing, ensuring glue is extruded from the end and sealed by pinching the end of each piece with pliers (Refer to figure #7).



Figure 7: QLS Pigtail Wire Sealing

7. Once all four wires are sealed, reconnect the pigtail to the chassis harness connector.

8. Secure the harness using a zip tie (Refer to figure #8).



Figure 8: QLS Pigtail Installed

- Item 1: Zip tie securing the harness
- Item 2: Pigtail connected to chassis connector
- Item 3: Harness to QLS left unsealed

9. Complete the vehicle programming as needed, for Cummins powered vehicle create a new post calibration health report prior to disconnecting the service tool and interface cable.

IMPORTANT:

A customer letter should be provided to the driver and placed in each vehicle that receives the software. Ensure that the operator fully understand the impacts and effects of the DEF gauge prior to releasing the vehicle. Refer to Cummins TRP2489 for the required documentation.

Navistar Programming Procedure

Refer to [NED Programming Procedure](#)

Optional Window Cling

In an effort to improve driver awareness Navistar has developed an optional static cling sticker (see figure #9) that can be installed on the windshield. Each dealer was provided an initial shipment of clings free of charge based on previous parts order volume. It is recommended that this be placed in a locate that is visible to the driver however does not obstruct their view, see figure #10 for examples.

If additional window clings are desired:

Dealers may order from the print portal:

- US Dealer Print Portal: [Navistar Print Portal - Online Store](#)
- Canadian Dealer Print Portal: [Canadian Navistar Print Portal - Online Store](#)

Customers and fleets may order window clings from the Navistar tools catalog

- Tools Catalog: [Navistar Service Tools Catalog](#)

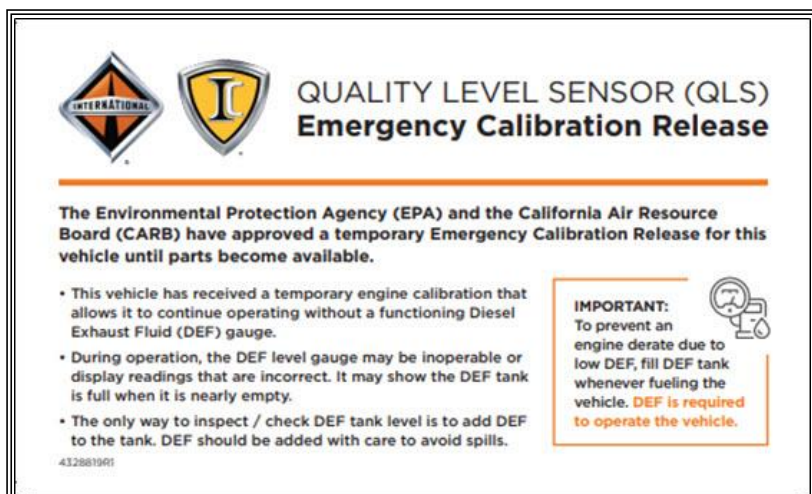

Figure 9: Window Static Cling Sticker (3 inch x 5 inch)

Part Number	Language
4328819R1	English
F4328819R1	French
M4328819R1	Spanish



Figure 10: Window Cling Installation options

Place the cling in a location on the window that is visible to the driver but does not obstruct their view.

DEF Cluster Alarm

Depending on the DLB parameter setting the cluster may produce an audible alarm for low DEF level. **This should only be checked if there is a complaint or it is known to have been changed.** The default setting is set to "No Alarm", if the parameter has been changed it will need to be returned to the original setting of "No Alarm". Refer to the image below.

T	Feature	Description	...
*0597082	BCM PROG, DEF Gauge & Warning Indicator		<input checked="" type="checkbox"/>
*0597391	BCM PROG, DEF TANK CAPACITY for 12 U.S. Gal. 45.4L Capacity		<input type="checkbox"/>
*0597368	BCM PROG, DEF TANK CAPACITY for 15 U.S. Gal. 56.8L Capacity		<input type="checkbox"/>
*0597367	BCM PROG, DEF TANK CAPACITY for 7 U.S. Gal. 26.5L Capacity		<input type="checkbox"/>
*0597366	BCM PROG, DEF TANK CAPACITY for 5 U.S. Gal. 18.9L Capacity		<input type="checkbox"/>
*0597365	BCM PROG, DEF TANK CAPACITY for 9.5 U.S. Gal. 35.9L Capacity		<input type="checkbox"/>
*0597238	BCM PROG, DEF ECON & DIST TO E Cummins Engines		<input type="checkbox"/>
*0597237	BCM PROG, DEF ECON & DIST TO E A26 Engines		<input type="checkbox"/>
*0597235	BCM PROG, DEF TANK CAPACITY for 25.2 U.S. Gal. 95.3L Capacity		<input type="checkbox"/>
*0597234	BCM PROG, DEF TANK CAPACITY for 15.9 U.S. Gal. 60.1L Capacity		<input type="checkbox"/>

T	ID	Parameter	Value	Unit	Description	Cfg. V...	Cfg. Unit
	2857	DEF Level_Min WL	10	percent	Minimum set point for DEF level in-gauge warning light	25	perc...
	2858	DEF Level_Max WL	100	percent	Maximum set point for DEF level in-gauge warning light	250	perc...
	2860	DEF Level_Filter Param	250	No U...	DEF level gauge update rate.A value of 1 is the slowes...	250	No U...
	2859	DEF Level_Alrm Ty Param	0	No U...		0	No U...

T	Description	Value
	Continuous Single Tone	1
	Five-short beeps	4
	No Alarm	0
	One-long beep	2
	One-short beep	3
	Repetitive short beeps	7
	Ten-short beeps	5
	Three-long beeps	6

Figure 11: DLB Cluster Alarm Parameter Setting

Under the feature 597082 for "DEF Gauge & Warning Indicator"
Ensure parameter ID 2859 for "DEF Level Alrm" is set to "0" or "No Alarm"

FREQUENTLY ASKED QUESTIONS (FAQ):

How do I get a Cummins fleet count?

- Phone: Dial 1-800-Cummins and choose option 1, followed by options 1 and 6
- Email:
 - If in the US please use the following email address: fleetcountzapit@cummins.com
 - If in Canada please use the following email address: cec.tools@cummins.com (Eastern Canada) & cwceetools@cummins.com (Western Canada)

How do I perform the software update?

- Refer to [Cummins Insite Support Page](#).

Who pays for calibration, fleet count and diagnostic time?

- For Cummins powered vehicles, only if the QLS emergency calibration is installed, it will be filed and paid through the TRP# [T2489](#).
- For Navistar powered vehicle, only if the QLS emergency calibration is installed, it will be filed and paid through AFC #[21901](#)

Can I replace the QLS after the calibration is installed?

- No, it will be replaced through a future action, Navistar and Cummins will provide documentation for this action at a later date once the parts supply has stabilized. Until then the failed QLS should remain in the vehicle.

Can the sensor connector be left unplugged?

- No, the sensor connector cannot be left unplugged. Exposure to environmental conditions could induce other failures once the sensor is replaced at a later date. Please follow the repair procedure to cut and seal the sensor pigtail.

Can the calibration be used on faults other than the ones listed in this article?

- No, the calibration has only been approved for the fault listed in this article. If other faults are determined to be caused by a QLS failure the sensor will need to be replaced.

What if the QLS is causing a short on the aftertreatment datalink for V-Ref circuits while also setting communication faults?

- If the QLS is the cause, following the steps outlined under the repair section will remove the QLS electrically from the chassis harness correcting the short.

Do I need to replace the DEFTHV at the same time as installing the calibration?

- No, there is no need to flow test or replace the DEFTHV at this time. It will be handled in future actions when the QLS is replaced. If it is determined the DEFTHV is needed due to a tank not being able to thaw, it will need to be diagnosed and replaced under standard warranty.

How do I handle vehicles where my parts order is cancelled, however the failure does not qualify for the calibration?

- Place a new critical unit down order (with VIN) for the QLS and reference the old order in the case file.

If I had a QLS on order and already did initial diagnostics prior to the cal becoming available, do I need to do the diagnostics again before putting the cal in?

- No, we only need to ensure the circuit diagnostics have been performed prior to installing the calibration. If that has already been performed there is no need to repeat them.

I have a vehicle that the sensor was pulled out of to repair another vehicle, how do I handle this repair?

- A replacement sensor will need to be installed, the vehicle cannot operate without a QLS installed.

Is there a need to seal the wiring to the QLS?

- No, since the sensor has failed, it will be replaced at a later date. The wiring on the chassis side must be sealed.

Can the heat shrink, and zip tie be filed under the Cummins TRP?

- Yes, the TRP was updated to include the heat shrink and zip tie needed on 10/21/21.
- Any claims filed prior to this date that the heat shrink and zip tie were used please review with your local DSM.

If the TRP has already been completed prior to the release of the pigtail cutting procedure, should the vehicle be brought back in to have the harness cut?

- If the truck has not been released it should have the harness cut. If the truck has been released to service, it should not be taken out of service without a complaint.

How do I know if a truck already back in service needs the harness cut?

- If the driver notes the DEF gauge returns to working that is an indication the faults are intermittent, the driver may also notice a cluster tone every time the gauge drops back out. Or if any other fault codes from SPN 3364, 3031 or 1761 are present the harness should be cut.

If a truck returns and requires the harness cut, who pays for the claim?

- This should be filed under the standard vehicle warranty or consult your local DSM.

Why is there no additional labor provided for the harness cutting procedure?

- The harness cutting procedure is intended to be performed simultaneously with the programming event resulting in the time overlapping.

For the Navistar engine calibrations, can it be programmed through NavKal?

- No, the programming option is only available through NEDs when the fault codes are present

For the Navistar engine calibration, how do i recover a blank ECM after a failure in the programming?

- First try reconnecting to the vehicle with NEDs, the software should try to restart the calibration process where it left off. If for some reason this does not work please create a case file with Navistar.

For the Navistar engine calibration, how likely is a programming failure to occur?

- In testing, the only failures that occurred were intentionally induced for testing. So, we don't expect any failures, however the most likely cause of a failure are from low battery conditions on the vehicle and/or the laptop.

WARRANTY INFORMATION

Warranty Claim Coding:

Refer to Cummins TRP # [T2489](#) and file the warranty claim with Cummins

Refer to Navistar AFC #[21901](#) and file the warranty claim with Navistar

Standard Repair Time(s):

Refer to Cummins TRP # [T2489](#) and file the warranty claim with Cummins

Refer to Navistar AFC #[21901](#) and file the warranty claim with Navistar

OTHER RESOURCES

[Master Service Information Site](#)

[AFC #21901 Quality Level Sensor \(QLS\) Emergency Calibration Release](#)

[Navistar Customer Reference Sheet 4328818R1](#)

[G-Letter G-19-100983 QLS Emergency Calibration](#)

[Cummins Quick Serve Online](#)

[TRP # T2489 ECM Calibration for DEF Header Sensor Failures due to Parts Shortage TRP for Navistar Vehicles](#)

[TSB210187 - Fault Codes 3868, 4572 and 4677 Caused by Diesel Exhaust Fluid \(DEF\) Header Malfunction](#)

 Hide Details

Feedback Information

Viewed: 8501
Helpful: 31
Not Helpful: 1

No Feedback Found