

AMB7 - Replacing Axle Carrier Side Section (Recall Campaign)

Model Line: **Boxster (981)
Cayman (981)**

Model Year: **As of 2013 up to 2015**

Concerns: **Carrier side section on the rear axle at the left and right**

Information: **There is a possibility that carrier side sections on the rear axle that do not meet the required specifications due to a manufacturing error were installed on the affected vehicles over a certain period of time.**

If this is the case, one or both supports of the transverse control units on the carrier side section may break over the service life of the vehicle. Fracture of both carriers would impair the wheel guide. Potential loss of control over the vehicle cannot be ruled out in this case.

Action required: **Replace axle carrier side sections.**

Affected Vehicles: Only vehicles assigned to the campaign (see also PCSS Vehicle Information).



Information

Each vehicle affected by this measure has been assigned **exactly one scope**.

For details of the exact scope of this campaign that is assigned to each vehicle, see PCSS Vehicle Information.

Installation
Position:

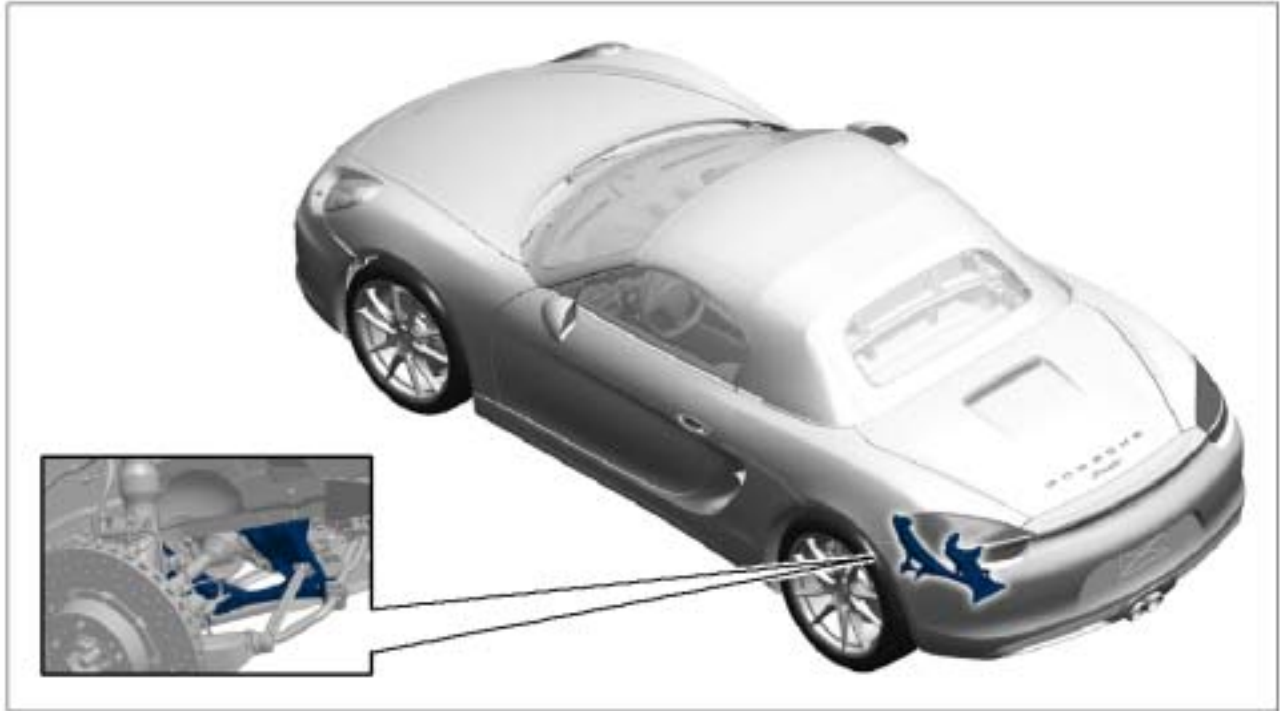

Installation place of rear-axle carrier side section shown on the Boxster (981)

Parts required



Information

To determine the parts required depending on the allocated action scope, see ⇒ *Technical Information 'Warranty processing'*.

Parts Info:

Part No.	Designation – Use	Qty.
V04015800AM	⇒ Rear-axle carrier side section – left	1 ea.
V04015800AN	⇒ Rear-axle carrier side section – right	1 ea.
99907284301	⇒ Combination screw, M10 x 80 – Rear-axle carrier side section to body	2 ea.

99907282901	⇒ Hexagon-head bolt, M10 x 45 – Rear axle carrier side part to cross member	2 ea.
PAF008868	⇒ Hexagon nut, M10 – Rear axle carrier side part to cross member	2 ea.
99733121703	⇒ Eccentric screw – Wishbone to rear axle carrier	2 ea.
99908444501	⇒ Lock nut, M12 x 1.5 – Wishbone to rear-axle carrier side section	2 ea.
99908444909	⇒ Lock nut, M12 x 1.5 – Wishbone to wheel carrier	2 ea.
99907289001	⇒ Lock nut, M12 x 1.5 – Diagonal arm to wishbone	2 ea.
PAF103353	⇒ Lock nut, M12 x 1.5 – Diagonal arm to wishbone	2 ea.
99908412309	⇒ Collar nut, M10 – Connecting link to anti-roll bar	2 ea.

Additional for vehicles with PCCB (Porsche Ceramic Composite Brake) (I-no. 450):

9A700758500	⇒ Cheese head bolt, M12 x 1.5 x 85 – Brake calliper to wheel bearing housing	4 ea.
-------------	---	-------

or

Additional for vehicles without PCCB (Porsche Ceramic Composite Brake)

99907340201	⇒ Cheese head bolt, M12 x 1.5 x 72 – Brake calliper to wheel bearing housing	4 ea.
-------------	---	-------

Required tools

- Tools:
- Torque wrench, 2-10 Nm (1.5-7.5 ftlb.), e.g. **VAG 1783 Torque wrench, 2-10 Nm (1.5-7.5 ftlb.)**
 - Torque wrench, 6-50 Nm (4.5-37 ftlb.), e.g. **VAG 1331A Torque wrench, 6-50 Nm (4.5-37 ftlb.)**
 - Torque wrench, 20-100 Nm (15-74 ftlb.), e.g. **VAS 5820 Torque wrench, 20-100 Nm (15-74 ftlb.) or equivalent**
 - Torque/torque angle wrench, 20-400 Nm (15-296 ftlb.), e.g. **VAS 6942 Digital torque wrench, 20-400 Nm (15-296 ftlb.) or equivalent**
 - Torque wrench, 40-200 Nm (30-148 ftlb.), e.g. **VAG 1332 Torque wrench, 40-200 Nm (30-148 ftlb.)**
 - **9626 - 9626 - Insert for torque wrench**
 - **9847 - 9847 - Socket-wrench insert**
 - **9730 - 9730 - Socket-wrench insert**
 - **VAS 6931 - Engine and gearbox jack**
 - **9560 - 9560 - Press-out tool**
 - **VAS 6862 Steering wheel alignment gauge**

- VAS 6918 Quick-clamping unit
- 9229/1 - Puller hook

Replacing rear-axle carrier side sections

- Action required:
- 1 Move the vehicle onto a lifting platform and raise it. ⇒ *Workshop Manual '4X00IN Lifting the vehicle'*.
 - 2 Remove the wheels on the rear axle. ⇒ *Workshop Manual '440519 Removing and installing wheel'*.
 - 3 Replace both rear-axle carrier side sections.
For instructions, see:
⇒ *Workshop Manual '423819 Removing and installing rear-axle carrier side section'*.
 - 4 Install the wheels on the rear axle. ⇒ *Workshop Manual '440519 Removing and installing wheel'*.
 - 5 Lower the vehicle and remove it from the lifting platform. ⇒ *Workshop Manual '4X00IN Lifting the vehicle'*.
 - 6 Perform suspension alignment and make adjustments. ⇒ *Workshop Manual '449503 Suspension alignment, complete'*.
 - 7 Document the condition of the removed rear-axle carrier side sections.

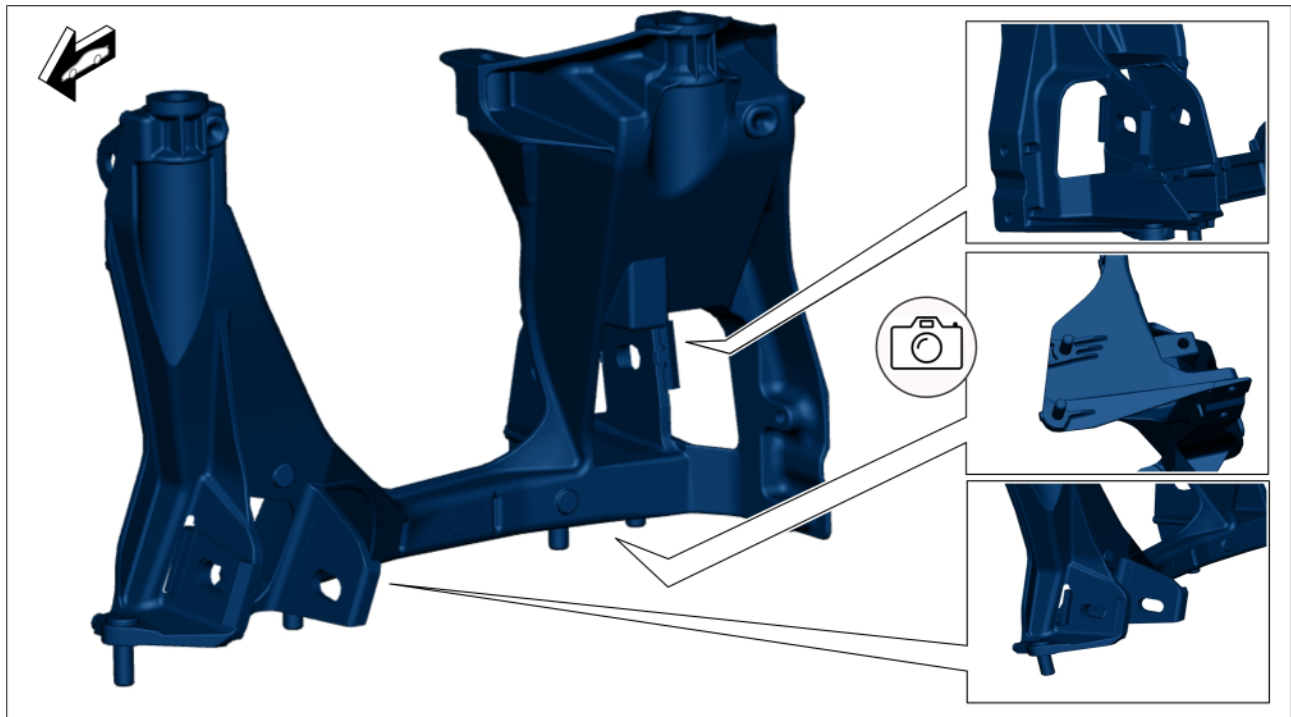

Photo documentation of rear-axle carrier side section

- 7.1 **Take photos** of the **jacking points on the rear-axle carrier side section at the left and right** shown in ⇒ *Photo documentation of rear-axle carrier side section -Picture-*.
- 7.2 Upload the **pictures** to the PCCS quality line with the relevant **inscription** on the affected side, e.g. **Component left_VIN_Fig 1**.

8 Enter the campaign in the Warranty and Maintenance booklet.

Warranty processing



Information

The specified working times were determined specifically for carrying out this campaign and include all required preliminary and subsequent work.

The working times may differ from the working times published in the Labor Operation List in PCSS.

Scope 1:

- **Vehicles without PCCB (Porsche Ceramic Composite Brake)**

Working time:		
Replacing rear-axle carrier side section at the left and right		Labor time: 484 TU
Includes:		
Lifting and lowering the vehicle		
Removing and installing wheels on rear axle		
Removing and installing rear cover		
Removing and installing anti-roll bar		
Removing and installing support plate		
Removing and installing struts		
Removing and installing trailing arm		
Removing and installing tie rods		
Removing and installing rear axle carrier		
Performing suspension alignment and adjusting vehicle at front and rear		
Testing and adjusting steering-angle sensor for PSM		
Parts required:		
V04015800AM	Rear-axle carrier side section, left	1 ea.
V04015800AN	Rear-axle carrier side section, right	1 ea.
99907340201	Cheese head bolt, M12	4 ea.
99907284301	Combination screw, M10	2 ea.
99907282901	Hexagon-head bolt, M10	2 ea.
99733121703	Eccentric screw	2 ea.
99908444501	Lock nut, M12	2 ea.

99908444909	Lock nut, M12	2 ea.
99907289001	Lock nut, M12	2 ea.
PAF103353	Lock nut, M12	2 ea.
99908412309	Collar nut, M10	2 ea.
PAF008868	Hexagon nut, M10	2 ea.

⇒ **Damage Code AMB7 099 000 2**

Scope 2:

- **Vehicles with PCCB (Porsche Ceramic Composite Brake) (I-no. 450)**

Working time:

Replacing rear-axle carrier side section at the left and right

Labor time: **484 TU**

Includes:

Lifting and lowering the vehicle
 Removing and installing wheels on rear axle
 Removing and installing rear cover
 Removing and installing anti-roll bar
 Removing and installing support plate
 Removing and installing struts
 Removing and installing trailing arm
 Removing and installing tie rods
 Removing and installing rear axle carrier
 Performing suspension alignment and adjusting vehicle at front and rear
 Testing and adjusting steering-angle sensor for PSM

Parts required:

V04015800AM	Rear-axle carrier side section, left	1 ea.
V04015800AN	Rear-axle carrier side section, right	1 ea.
9A700758500	Cheese head bolt, M12	4 ea.
99907284301	Combination screw, M10	2 ea.
99907282901	Hexagon-head bolt, M10	2 ea.
99733121703	Eccentric screw	2 ea.
99908444501	Lock nut, M12	2 ea.
99908444909	Lock nut, M12	2 ea.
99907289001	Lock nut, M12	2 ea.
PAF103353	Lock nut, M12	2 ea.

99908412309	Collar nut, M10	2 ea.
PAF008868	Hexagon nut, M10	2 ea.

⇒ Damage Code AMB7 099 000 2

Scope 3:

- **Vehicles without PCCB (Porsche Ceramic Composite Brake)**
- **Automatic distance control (ADC) (I-no. 456)**

Working time:

Replacing rear-axle carrier side section at the left and right

Labor time: **525 TU**

Includes:

- Lifting and lowering the vehicle
- Removing and installing wheels on rear axle
- Removing and installing rear cover
- Removing and installing anti-roll bar
- Removing and installing support plate
- Removing and installing struts
- Removing and installing trailing arm
- Removing and installing tie rods
- Removing and installing rear axle carrier
- Performing suspension alignment and adjusting vehicle at front and rear
- Testing and adjusting steering-angle sensor for PSM
- Adjusting distance sensor control unit

Parts required:

V04015800AM	Rear-axle carrier side section, left	1 ea.
V04015800AN	Rear-axle carrier side section, right	1 ea.
99907340201	Cheese head bolt, M12	4 ea.
99907284301	Combination screw, M10	2 ea.
99907282901	Hexagon-head bolt, M10	2 ea.
99733121703	Eccentric screw	2 ea.
99908444501	Lock nut, M12	2 ea.
99908444909	Lock nut, M12	2 ea.
99907289001	Lock nut, M12	2 ea.
PAF103353	Lock nut, M12	2 ea.
99908412309	Collar nut, M10	2 ea.
PAF008868	Hexagon nut, M10	2 ea.

⇒ Damage Code AMB7 099 000 2

Scope 4:

- **Vehicles with PCCB (Porsche Ceramic Composite Brake) (I-no. 450)**
- **Automatic distance control (ADC) (I-no. 456)**

Working time:

Replacing rear-axle carrier side section at the left and right

Labor time: **525 TU**

Includes:

Lifting and lowering the vehicle
 Removing and installing wheels on rear axle
 Removing and installing rear cover
 Removing and installing anti-roll bar
 Removing and installing support plate
 Removing and installing struts
 Removing and installing trailing arm
 Removing and installing tie rods
 Removing and installing rear axle carrier
 Performing suspension alignment and adjusting vehicle at front and rear
 Testing and adjusting steering-angle sensor for PSM
 Adjusting distance sensor control unit

Parts required:

V04015800AM	Rear-axle carrier side section, left	1 ea.
V04015800A	Rear-axle carrier side section, right	1 ea.
9A700758500	Cheese head bolt, M12	4 ea.
99907284301	Combination screw, M10	2 ea.
99907282901	Hexagon-head bolt, M10	2 ea.
99733121703	Eccentric screw	2 ea.
99908444501	Lock nut, M12	2 ea.
99908444909	Lock nut, M12	2 ea.
99907289001	Lock nut, M12	2 ea.
PAF103353	Lock nut, M12	2 ea.
PAF008868	Hexagon nut, M10	2 ea.
99908412309	Collar nut, M10	2 ea.

⇒ **Damage Code AMB7 099 000 2**

Scope 5:

- **Vehicles without PCCB (Porsche Ceramic Composite Brake)**
- **Speed limit display (traffic sign recog.) (I-no. 631)**

Working time:

Replacing rear-axle carrier side section at the left and right

Labor time: **509 TU**

Includes:

- Lifting and lowering the vehicle
- Removing and installing wheels on rear axle
- Removing and installing rear cover
- Removing and installing anti-roll bar
- Removing and installing support plate
- Removing and installing struts
- Removing and installing trailing arm
- Removing and installing tie rods
- Removing and installing rear axle carrier
- Performing suspension alignment and adjusting vehicle at front and rear
- Testing and adjusting steering-angle sensor for PSM
- Front camera programmed

Parts required:

V04015800AM	Rear-axle carrier side section, left	1 ea.
V04015800AN	Rear-axle carrier side section, right	1 ea.
99907340201	Cheese head bolt, M12	4 ea.
99907284301	Combination screw, M10	2 ea.
99907282901	Hexagon-head bolt, M10	2 ea.
99733121703	Eccentric screw	2 ea.
99908444501	Lock nut, M12	2 ea.
99908444909	Lock nut, M12	2 ea.
99907289001	Lock nut, M12	2 ea.
PAF103353	Lock nut, M12	2 ea.
PAF008868	Hexagon nut, M10	2 ea.
99908412309	Collar nut, M10	2 ea.

⇒ **Damage Code AMB7 099 000 2**

Scope 6:

- **Vehicles with PCCB (Porsche Ceramic Composite Brake) (I-no. 450)**
- **Speed limit display (traffic sign recog.) (I-no. 631)**

Working time:

Replacing rear-axle carrier side section at the left and right

Labor time: **509 TU**

Includes:

Lifting and lowering the vehicle
 Removing and installing wheels on rear axle
 Removing and installing rear cover
 Removing and installing anti-roll bar
 Removing and installing support plate
 Removing and installing struts
 Removing and installing trailing arm
 Removing and installing tie rods
 Removing and installing rear axle carrier
 Performing suspension alignment and adjusting vehicle at front and rear
 Testing and adjusting steering-angle sensor for PSM
 Front camera programmed

Parts required:

V04015800AM	Rear-axle carrier side section, left	1 ea.
V04015800AN	Rear-axle carrier side section, right	1 ea.
9A700758500	Cheese head bolt, M12	4 ea.
99907284301	Combination screw, M10	2 ea.
99907282901	Hexagon-head bolt, M10	2 ea.
99733121703	Eccentric screw	2 ea.
99908444501	Lock nut, M12	2 ea.
99908444909	Lock nut, M12	2 ea.
99907289001	Lock nut, M12	2 ea.
PAF103353	Lock nut, M12	2 ea.
PAF008868	Hexagon nut, M10	2 ea.
99908412309	Collar nut, M10	2 ea.

⇒ **Damage Code AMB7 099 000 2**

Scope 7:

- **Vehicles without PCCB (Porsche Ceramic Composite Brake)**
- **Speed limit display (traffic sign recog.) (I-no. 631)**
- **Automatic distance control (ADC) (I-no. 456)**

Working time:

Replacing rear-axle carrier side section at the left and right

Labor time: **540 TU**

Includes:

- Lifting and lowering the vehicle
- Removing and installing wheels on rear axle
- Removing and installing rear cover
- Removing and installing anti-roll bar
- Removing and installing support plate
- Removing and installing struts
- Removing and installing trailing arm
- Removing and installing tie rods
- Removing and installing rear axle carrier
- Performing suspension alignment and adjusting vehicle at front and rear
- Testing and adjusting steering-angle sensor for PSM
- Front camera programmed
- Adjusting distance sensor control unit

Parts required:

V04015800AM	Rear-axle carrier side section, left	1 ea.
V04015800AN	Rear-axle carrier side section, right	1 ea.
99907340201	Cheese head bolt, M12	4 ea.
99907284301	Combination screw, M10	2 ea.
99907282901	Hexagon-head bolt, M10	2 ea.
99733121703	Eccentric screw	2 ea.
99908444501	Lock nut, M12	2 ea.
99908444909	Lock nut, M12	2 ea.
99907289001	Lock nut, M12	2 ea.
PAF103353	Lock nut, M12	2 ea.
PAF008868	Hexagon nut, M10	2 ea.
99908412309	Collar nut, M10	2 ea.

⇒ **Damage Code AMB7 099 000 2**

Scope 8:

- **Vehicles with PCCB (Porsche Ceramic Composite Brake) (I-no. 450)**
- **Speed limit display (traffic sign recog.) (I-no. 631)**
- **Automatic distance control (ADC) (I-no. 456)**

Working time:

Replacing rear-axle carrier side section at the left and right

Labor time: **540 TU**

Includes:

Lifting and lowering the vehicle
 Removing and installing wheels on rear axle
 Removing and installing rear cover
 Removing and installing anti-roll bar
 Removing and installing support plate
 Removing and installing struts
 Removing and installing trailing arm
 Removing and installing tie rods
 Removing and installing rear axle carrier
 Performing suspension alignment and adjusting vehicle at front and rear
 Testing and adjusting steering-angle sensor for PSM
 Front camera programmed
 Adjusting distance sensor control unit

Parts required:

V04015800AM	Rear-axle carrier side section, left	1 ea.
V04015800AN	Rear-axle carrier side section, right	1 ea.
9A700758500	Cheese head bolt, M12	4 ea.
99907284301	Combination screw, M10	2 ea.
99907282901	Hexagon-head bolt, M10	2 ea.
99733121703	Eccentric screw	2 ea.
99908444501	Lock nut, M12	2 ea.
99908444909	Lock nut, M12	2 ea.
99907289001	Lock nut, M12	2 ea.
PAF103353	Lock nut, M12	2 ea.
PAF008868	Hexagon nut, M10	2 ea.
99908412309	Collar nut, M10	2 ea.

⇒ **Damage Code AMB7 099 000 2**

Important Notice: Technical Bulletins issued by Porsche Cars North America, Inc. are intended only for use by professional automotive technicians who have attended Porsche service training courses. They are written to inform those technicians of conditions that may occur on some Porsche vehicles, or to provide information that could assist in the proper servicing of a vehicle. Porsche special tools may be necessary in order to perform certain operations identified in these bulletins. Use of tools and procedures other than those Porsche recommends in these bulletins may be detrimental to the safe operation of your vehicle, and may endanger the people working on it. Properly trained Porsche technicians have the equipment, tools, safety instructions, and know-how to do the job properly and safely. Part numbers listed in these bulletins are for reference only. The work procedures updated electronically in the Porsche PIWIS diagnostic and testing device take precedence and, in the event of a discrepancy, the work procedures in the PIWIS Tester are the ones that must be followed.

© 2021 Porsche Cars North America, Inc.