



Technical Bulletin 219

09.2021

Contents

Item	Subject	Model Affected
219.1	Engine Oil and Filter Change	Speed Triple 1200 RS
219.2	Fuel Hose Disconnection	Rocket 3 GT, Rocket 3 R, Rocket 3 TFC, Rocket 3 GT Triple Black, Rocket 3 R Black
219.3	Chain Rubbing Strip	Tiger 900, Tiger 900 GT, Tiger 900 Rally, Tiger 900 GT Pro, Tiger 900 Rally Pro, Tiger 900 GT - LRH, Tiger 850 Sport
219.4	Triumph Diagnostic Tool - Suspension Diagnostics - Rear Preload Motor Function Tests	Tiger 900 GT Pro
219.5	Appendix A - Rear Suspension Unit - Rear Preload Motor Calibration	Tiger 900 GT Pro
219.6	Appendix B - Test Rear Preload Motor	Tiger 900 GT Pro

Item: 219.1
Description: Engine Oil and Filter Change
Model Affected: Speed Triple 1200 RS

A new procedure for the engine oil and oil filter change has been introduced for the above model. It has come to our attention that on a small number of the above models oil pressure warning light did not extinguish after an engine oil and oil filter change. Dealers should fill the engine with oil before the new oil filter is fitted. The revised procedure is described below.

Warning

Prolonged or repeated contact with engine oil can lead to skin dryness, irritation and dermatitis. In addition, used engine oil contains potentially harmful contamination which can cause cancer. Wear suitable clothing and avoid skin contact.

The engine oil and filter must be replaced in accordance with scheduled maintenance requirements.

Warning

If the engine has recently been running, the engine oil will be hot to the touch. Contact with the hot oils may cause damage to exposed skin. To avoid skin damage, do not touch hot oil.

Caution

Do not pour engine oil on the ground, down sewers or drains, or into watercourses. To prevent pollution of watercourses etc., dispose of used oil sensibly. If in doubt contact your local authority.

1. Warm up the engine thoroughly, and then stop the engine and secure the motorcycle in an upright position on level ground.
2. Remove the wire clip and detach the TSA shift force sensor from the gear change knuckle.

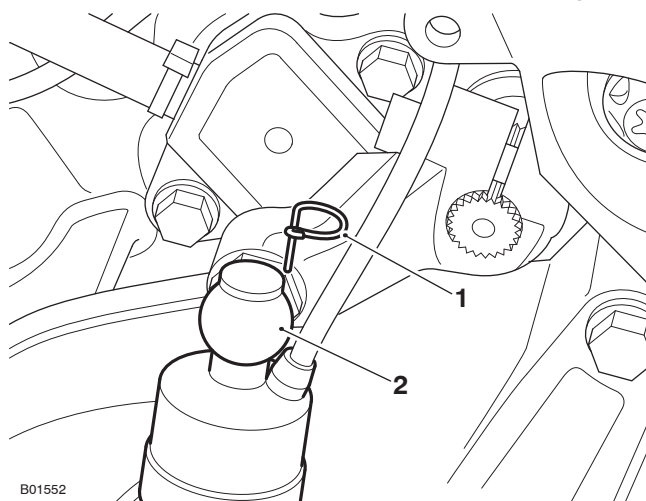

1. **Wire clip**
2. **TSA shift force sensor**

3. Release the fixings and remove the front sprocket outer cover.

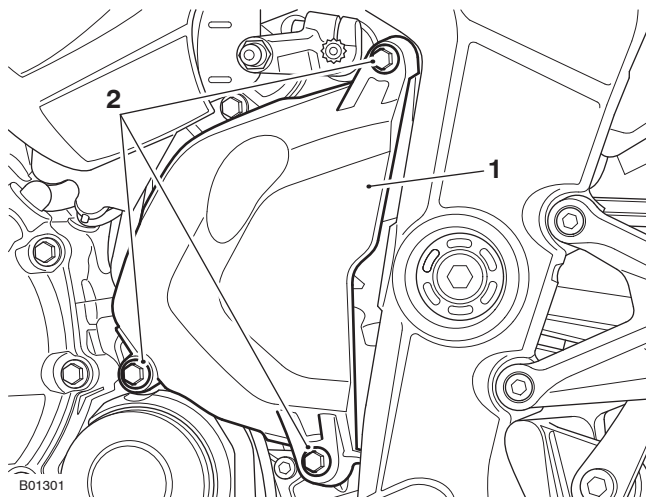

1. Sprocket cover
2. Fixings

Note:

- Note the orientation of the wire guide for installation.
 - Note the routing of the harness and hoses through the wire guide for installation.
4. Detach the side stand switch connector from the oil filter cover.
 5. Release the fixing and remove the engine oil filter cover and wire guide.

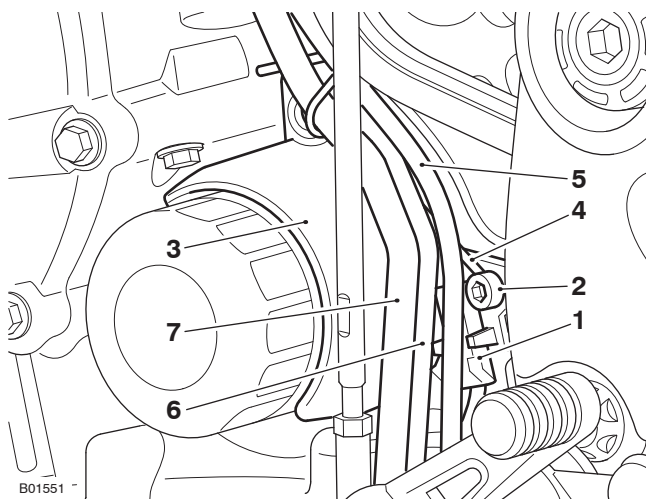

1. Side stand switch connector
 2. Fixing
 3. Cover
 4. Wire guide
 5. Engine subharness
 6. Fuel tank drain hose
 7. Coolant expansion tank drain hose
6. Place an oil pan beneath the engine.

- Remove the oil drain plug and discard the sealing washer.

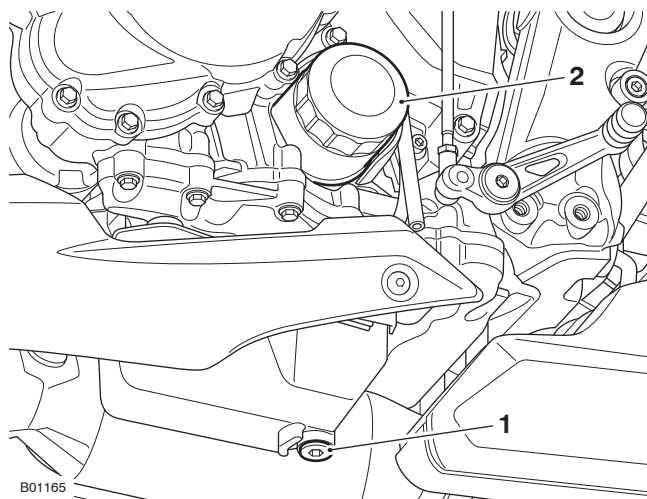

1. Oil drain plug

2. Oil filter

- Unscrew and remove the oil filter using **Service tool T3880313 - Oil Filter Wrench**. Dispose of the old oil filter in an environmentally friendly way.
- After the oil has completely drained out, fit a new sealing washer to the drain plug. Fit and tighten the plug to **25 Nm**.

Caution

Always fill the engine with clean oil prior to fitting the new oil filter.

Fitting the new oil filter before filling the engine may cause air to temporarily become trapped in the oil gallery.

Fitting the (dry) oil filter after refilling the engine with oil will prevent the possibility of the low oil pressure warning light illuminating.

- Fill the engine with a 10W/40 or 10W/50 semi or fully synthetic motorcycle engine oil that meets specification API SH (or higher) and JASO MA, such as Castrol Power 1 Racing 4T 10W-40 (fully synthetic).

Caution

A new oil filter must always be fitted each time the engine oil is replaced.

The oil filter must never be reused.

Reusing the filter may cause air to temporarily become trapped in the oil gallery and the oil pressure warning light to remain illuminated.

- Apply a smear of clean engine oil to the sealing ring of the new oil filter.
- Fit the new oil filter and tighten to **10 Nm** using **Service tool T3880313 - Oil Filter Wrench**.
- Fit the oil filter cover with the wire guide in the same orientation noted for removal. Tighten the fixing to **3 Nm**.
- Attach the side stand switch connector to the oil filter cover.

15. Route the harnesses and hoses through the wire guide as noted for removal.

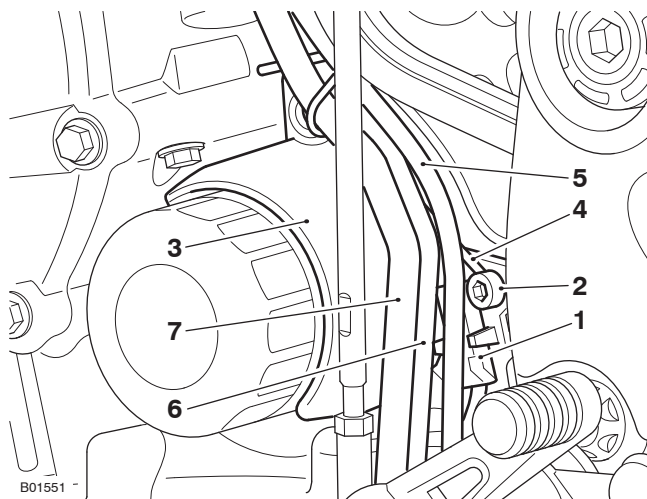

1. Side stand switch connector
2. Fixing
3. Cover
4. Wire guide
5. Engine subharness
6. Fuel tank drain hose
7. Coolant expansion tank drain hose

16. Position the sprocket cover to the crankcase with the coolant expansion tank hose, fuel tank vent hoses and the oxygen sensor harness positioned as noted for removal.

Note:

- Note the lower left hand fixing also secures the oil filter cover between the sprocket cover and crankcase.
17. Fit and tighten the fixings to **10 Nm**.

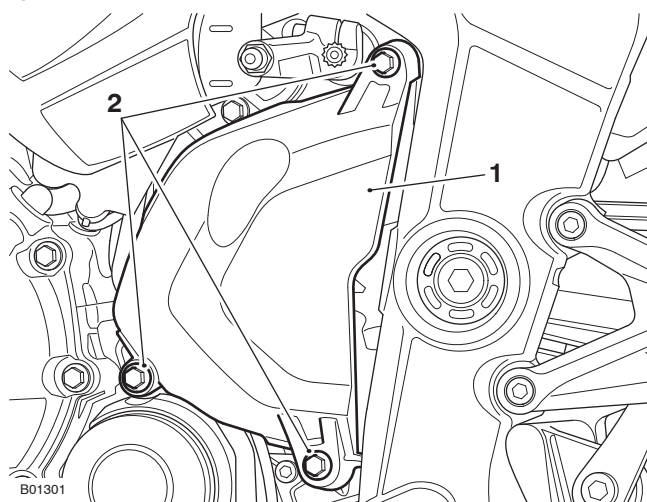

1. Sprocket cover
2. Fixings

18. Fit the TSA shift force sensor upper ball socket to the gear change knuckle ball joint and secure with the wire clip.

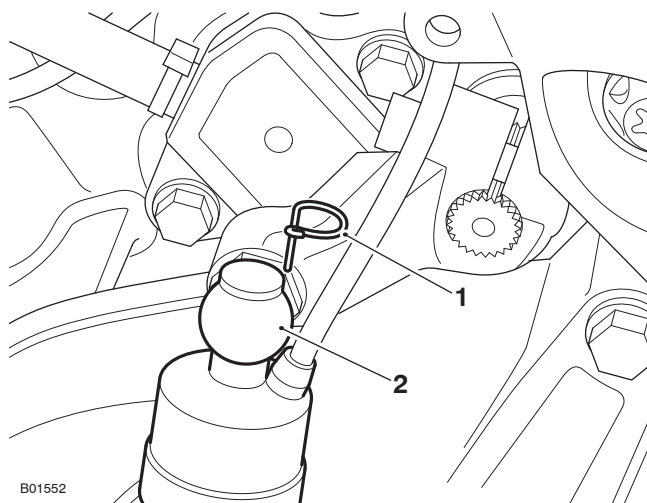

1. Wire clip
2. Ball socket

19. Start the engine and allow it to idle for a minimum of 30 seconds.

⚠ Caution

Raising the engine speed above idle before the oil reaches all parts of the engine can cause engine damage or seizure. Only raise engine speed after running the engine for 30 seconds to allow the oil to circulate fully.

⚠ Caution

If the engine oil pressure is too low, the low oil pressure warning light will illuminate. If this light stays on when the engine is running, stop the engine immediately and investigate the cause. Running the engine with low oil pressure will cause engine damage.

20. Make sure that the low oil pressure warning light remains off and the oil pressure message is not visible in the instrument display screen.
21. Stop the engine and check the oil level and adjust if necessary.

Please mark your copy of the Service Manual with this information. For electronic service manuals, store this information in a readily accessible place and refer to it when working on the relevant Triumph motorcycle. This information will be included in the next service manual update.

Item: 219.2

Description: Fuel Hose Disconnection

Model Affected: Rocket 3 GT, Rocket 3 R, Rocket 3 TFC, Rocket 3 GT Triple Black, Rocket 3 R Black

The Service Manual for the above model has been updated to include further information about the fuel line disconnection.

The removal of the fuel tank is as described in the Service Manual with the following changes for the fuel hose disconnect from the fuel rail.

1. To release the double check clip, ease the latch away from the connector until the release buttons are exposed.

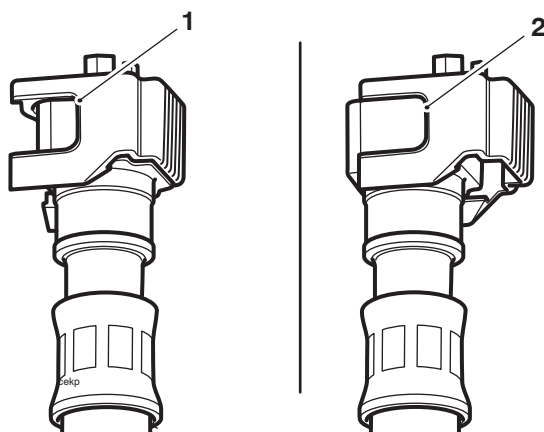

1. Locked Position

2. Unlocked Position

⚠ Caution

Do not pull on the fuel hose to disconnect the connector from the fuel rail.
Pulling on the fuel hose may damage the fuel hose connector.
Disconnect from the fuel line by lifting up the fuel hose connector.

-
2. Press in the release buttons (one either side of the fuel hose connector) to release the locking device.
 3. Without pulling on the fuel hose, lift up the fuel hose connector to disconnect it from the fuel rail.

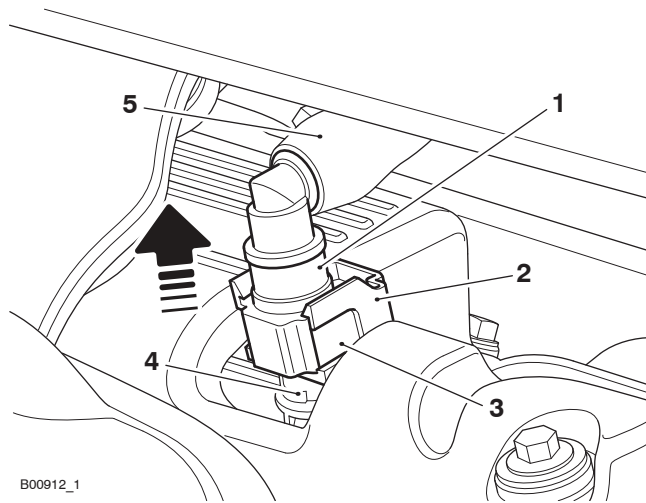

1. Fuel hose connector
2. Latch
3. Release button (one of two shown)
4. Fuel rail
5. Fuel hose

Item:	219.3
Description:	Chain Rubbing Strip
Model Affected:	Tiger 900, Tiger 900 GT, Tiger 900 Rally, Tiger 900 GT Pro, Tiger 900 Rally Pro, Tiger 900 GT - LRH, Tiger 850 Sport

The chain rubbing strip for the above models was changed at VIN AE7913 and the dampers that were fitted into the chain rubbing strip were deleted.

The service kit T3990129 now includes the chain rubbing strip part number T2052083. This chain rubbing strip can be fitted to all of the above models from the start of production.

- If you have an early service kit T3990129 that includes chain rubbing strip part T2051084 and dampers T2050997 and T2050998, you can still install these parts.
- If you have a service kit that includes chain rubbing strip part number T2052083 but also includes dampers T2050997 and T2050998, you cannot fit the dampers to this chain rubbing strip. Discard the dampers.
- Dampers T2050997 and T2050998 are now deleted from service kit T3990129.

Please mark your copy of the Service Manual with this information. For electronic service manuals, store this information in a readily accessible place and refer to it when working on the relevant Triumph motorcycle. This information will be included in the next service manual update.

When ordering replacement parts, refer to the EPC.

Item: 219.4

Description: Triumph Diagnostic Tool - Suspension Diagnostics - Rear Preload Motor Function Tests

Model Affected: Tiger 900 GT Pro

The rear preload motor function tests have been updated for the above model in the Suspension Diagnostics area of the Triumph Diagnostic Tool. The function tests now feature a guided workflow and are available from the TDT 2021-11 update onwards.

Changes are as follows:

Test Rear Preload Motor

There were previously two separate function tests (Rear Preload Motor Up and Rear Preload Motor Down). These have been combined under one rear preload motor function test.

Upon clicking Start, the tool will provide **Up** and **Down** buttons to allow the preload motor to be driven up and down.

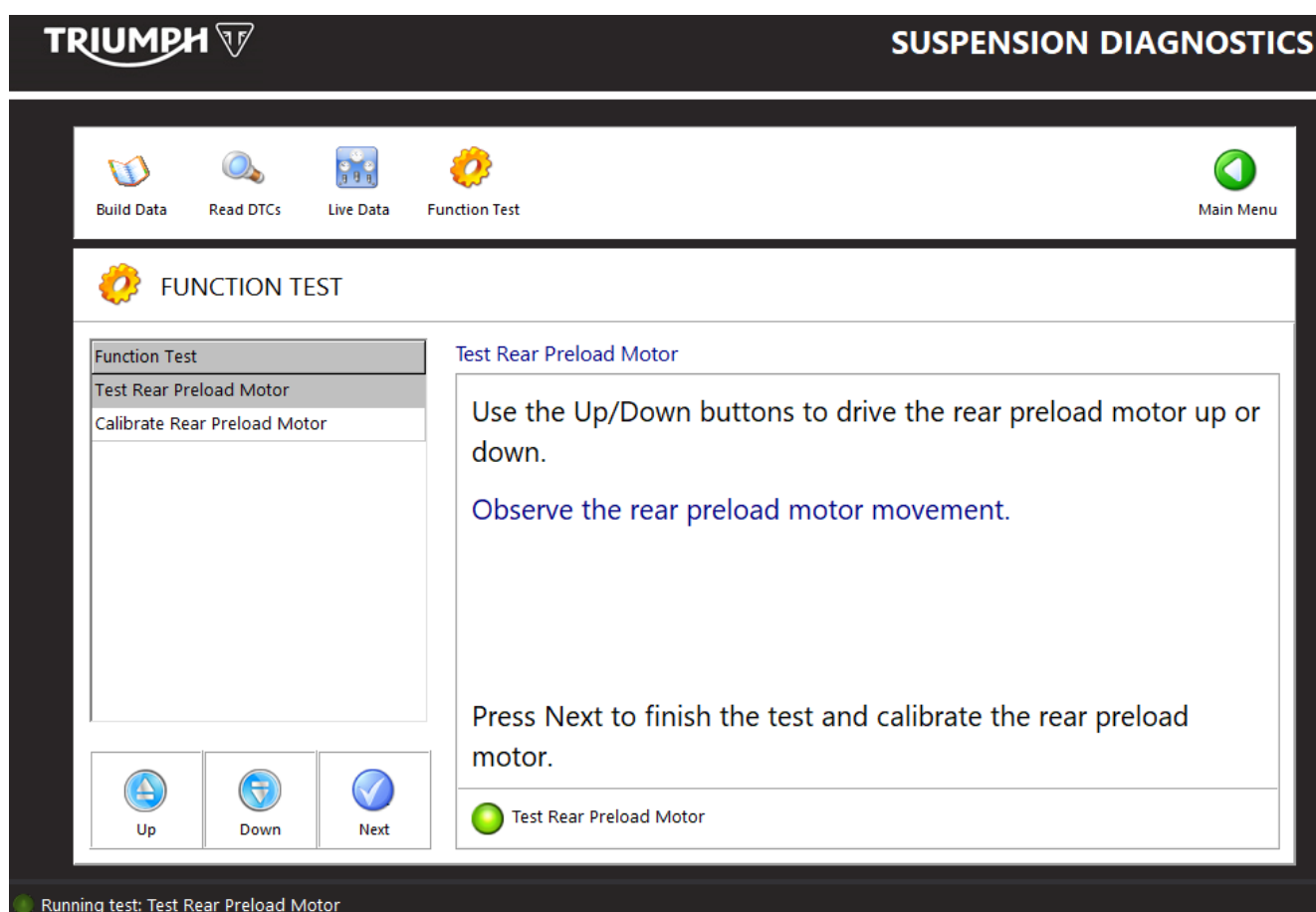

A **Next** button is also provided. Upon clicking **Next**, the tool will end the test and will automatically proceed to calibrate the rear preload motor. The tool will display onscreen instructions to guide users through the calibration process as described below.

Calibrate Rear Preload Motor

The new guided workflow ensures that the motorcycle is in the correct condition to allow the rear preload motor calibration to start.

It is no longer necessary to disconnect the diagnostic tool interface from the motorcycle after starting the rear preload motor calibration process.

The tool will display onscreen instructions to guide users through the rear preload motor calibration process:

- The tool will provide prompts on when to turn the motorcycle ignition OFF and ON.
- The tool will indicate when the rear preload motor calibration is in progress, and will provide confirmation when the calibration process has completed.

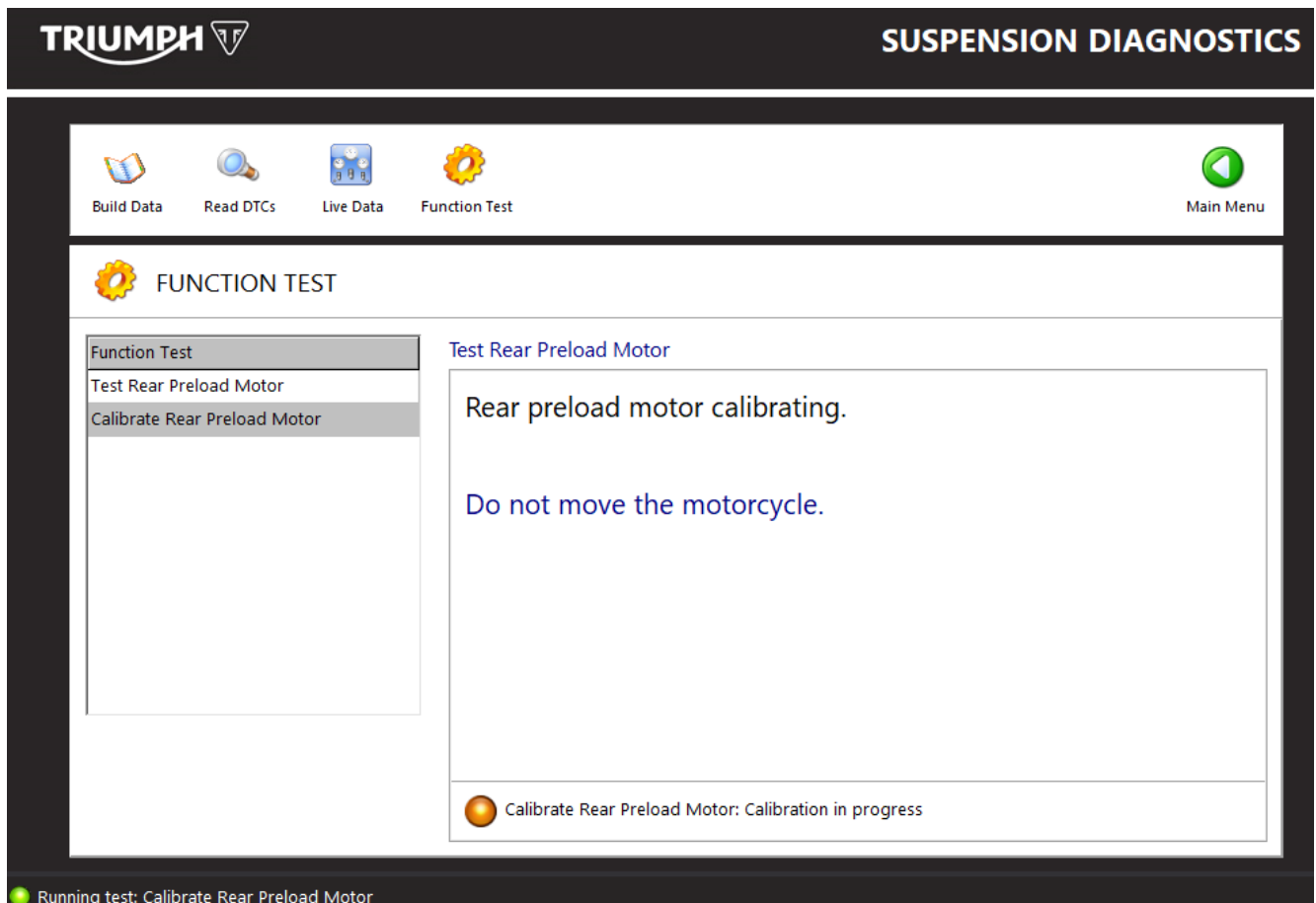

Service Manual Procedure Updates

The following procedures are updated as a result of the above changes.

- Rear Suspension Unit Preload Motor - Calibration. See Appendix A - Rear Suspension Unit - Rear Preload Motor Calibration, page 12.
- Rear Preload Motor Up/Down Function Tests. See Appendix B - Test Rear Preload Motor, page 14

Circulation

Initial and date when read and return to central file holder

Service Manager	Parts Manager	Sales Manager	Workshop Supervisor	Technician 1	Technician 2

Item:	219.5
Description:	Appendix A - Rear Suspension Unit - Rear Preload Motor Calibration
Model Affected:	Tiger 900 GT Pro

The rear preload motor must be calibrated under the following circumstances:

- After installation and setup of a new suspension ECM.
- After removal/installation of the rear suspension unit.

Note:

- **If installing a new suspension ECM, the rear preload motor will calibrate automatically after turning the ignition switch ON.**
- **If the rear suspension unit has been removed/refitted, the Triumph Diagnostic Tool must be used to calibrate the rear preload motor.**

Before Calibrating the Rear Preload Motor

Before calibrating the rear preload motor, check that the following motorcycle ECMs have the latest calibrations installed:

- Engine ECM
- Chassis ECM
- Suspension ECM
- Instruments

Calibrating the Rear Preload Motor using the Triumph Diagnostic Tool

Warning

Make sure the motorcycle is stabilised and adequately supported.
A correctly supported motorcycle will help prevent it from falling.
An unstable motorcycle may fall, causing injury to the operator or damage to the motorcycle.

Note:

- **Make sure the motorcycle battery is fully charged before calibrating the rear preload motor.**
1. Park the motorcycle on it's side stand.
 2. Remove the rider's seat.
 3. Connect the Triumph Diagnostic Tool to the motorcycle and turn the ignition On.
 4. From the main menu click CHASSIS DIAGNOSTICS, then click SUSPENSION DIAGNOSTICS.
 5. When the diagnostic tool has connected, click the **Function Tests** tab and select **Calibrate Rear Preload Motor** from the menu.

Note:

- **Upon clicking START, the diagnostic tool will send a command to the suspension ECM to perform an RSU preload motor calibration the next time the ignition is switched On.**
6. Click **Start**, then follow the onscreen instructions.
 - The tool will provide prompts on when to turn the motorcycle ignition OFF and ON.
 - The tool will indicate when the rear preload motor calibration is in progress, and will provide confirmation when the calibration process has completed.
 7. Click **Finish** when the rear preload motor calibration process has completed.

While Rear Preload Motor Calibration is in Progress

Note:

- When the rear preload motor is calibrating, the suspension warning light will flash on the instrument display and a message will be displayed indicating that the TES (Triumph Electronic Suspension) system is calibrating.
 - The motorcycle must remain stationary while the rear preload motor is calibrating. If the motorcycle is moved or ridden, this will halt the calibration process and the suspension warning light will be illuminated. In this situation the calibration process will be restarted the next time the ignition switch is turned Off for more than 30 seconds, then turned On again.
 - When the calibration process is complete, the suspension warning light will stop flashing and the instruments will briefly display a message indicating that calibration has completed.
 - After calibration has completed, the motorcycle may then proceed to adjust the rear preload motor to the settings selected on the instrument menus. In this situation, the instruments will briefly display a message indicating that the TES system is adjusting. When adjustment is complete, the instruments will return to the normal display.
1. Do not move or ride the motorcycle while the rear preload motor is calibrating.
 2. Wait for the suspension warning light to stop flashing to confirm that the rear preload motor calibration is complete.

After Rear Preload Motor Calibration has Completed

Warning

Never start the engine or let it run for any length of time in a closed area. The exhaust fumes are poisonous and may cause loss of consciousness and death within a short time. Always operate the motorcycle in the open-air or in an area with adequate ventilation.

1. Start the engine and check that the suspension warning light remains off. If the warning light resumes flashing, the rear preload motor is being recalibrated due to low battery voltage. Wait for the warning light to stop flashing before turning the engine off.
2. When the calibration has successfully completed, reconnect the Triumph Diagnostic Tool and erase any stored DTCs.
3. Refit the rider's seat.
4. Road test the motorcycle then recheck for any warning lights or stored DTCs. Investigate and rectify any faults as necessary.

Please mark your copy of the Service Manual with this information. For electronic service manuals, store this information in a readily accessible place and refer to it when working on the relevant Triumph motorcycle. This information will be included in the next service manual update.

Item: 219.6
Description: Appendix B - Test Rear Preload Motor
Model Affected: Tiger 900 GT Pro

The Test Rear Preload Motor function test provided in the Triumph Diagnostic Tool may be used as follows:

- To test the rear preload motor operation.
- To attempt to free the rear preload motor if it is stuck at an end stop.

Warning

Make sure the motorcycle is stabilised and adequately supported.
A correctly supported motorcycle will help prevent it from falling.
An unstable motorcycle may fall, causing injury to the operator or damage to the motorcycle.

To Access the Test Rear Preload Motor Function Test

1. Connect the Triumph diagnostic tool to the motorcycle and turn the ignition On.
2. From the main menu click CHASSIS DIAGNOSTICS, then click SUSPENSION DIAGNOSTICS.
3. When the diagnostic tool has connected, click the **Function Tests** tab and select **Test Rear Preload Motor** from the menu.

Testing Rear Preload Motor Operation

Caution

If the rear preload motor adjustment position reaches its maximum or minimum adjustment end stop, do not continue to drive the motor towards the end stop.
Select the test direction that will drive motor away from the end stop as described later in this procedure.
Repeatedly driving the rear preload motor against an end stop may cause the motor to overheat, which can result in permanent damage.

Note:

- **The position of the rear preload motor adjustment can be checked visually as follows:**
- **At the maximum preload end stop, the preload adjustment collar is fully extended from the base of the motor housing. Approximately 10 mm of the adjustment collar is visible as shown below.**
- **At intermediate preload adjustment positions, less of the adjustment collar will be visible as the adjustment position moves closer to the minimum preload end stop.**
- **At the minimum preload end stop, the preload adjustment collar is fully retracted into the motor housing.**

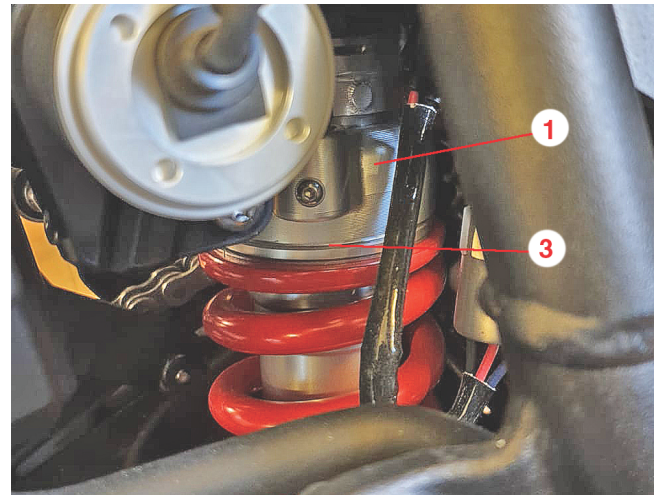
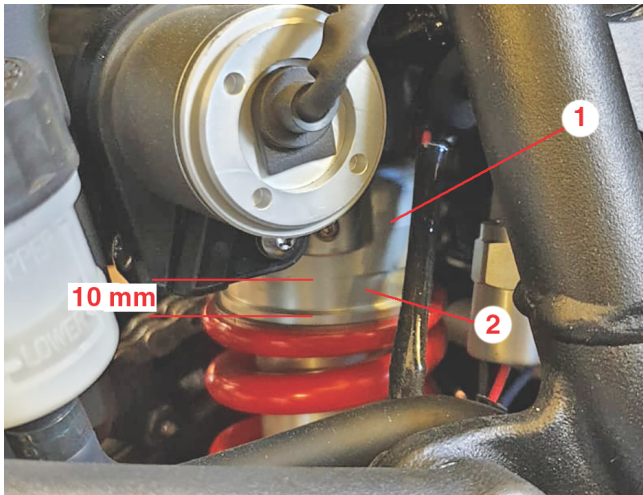

1. Rear preload motor housing
2. Adjustment collar (maximum preload position - fully extended)
3. Adjustment collar (minimum preload position - fully retracted)

⚠ Warning

Never start the engine or run the engine in a confined area. Exhaust fumes are poisonous and can cause loss of consciousness and death within a short period of time. Always operate your motorcycle in the open-air or in an area with adequate ventilation.

1. Start the engine.

Note:

- If the rear preload motor is positioned at or near the minimum or maximum adjustment end stop, the motor must first be driven away from the end stop, before testing in the opposite direction.
 - If the rear preload motor is at or near maximum preload (adjustment collar fully extended), click the **down** button first.
 - If the rear preload motor is at or near minimum preload (adjustment collar fully retracted), click the **Up** button first.
 - Upon clicking the Up or Down buttons, the rear preload motor adjustment collar will move approximately 1.0 mm in the selected direction.
 - It will take approximately ten repeated button clicks in either direction to operate the preload motor through its full adjustment range, however It is not necessary to do this to verify correct motor operation. Three to five repeated button clicks are sufficient to verify motor operation.
 - If the preload motor is operated through its full adjustment range (ten repeated button clicks), allow the motor to cool for five minutes before running further tests.
2. Click the **Up** or **Down** buttons as required and observe the rear preload motor adjustment collar movement. Wait for a few seconds between each button click to allow the rear preload motor time to operate.
 3. Verify correct motor operation in both directions.

Note:

- If no adjustment collar movement can be observed, check for any stored DTCs. Rectify as necessary and repeat the rear preload motor test. If the rear preload motor still doesn't function correctly, contact Triumph service.
4. When finished testing, click the **Next** button to proceed.
 5. The tool will automatically proceed to calibrate the rear preload motor. Follow all onscreen instructions. Refer to Appendix A - Rear Suspension Unit - Rear Preload Motor Calibration, page 12 for further information.
 6. Click **Finish** when rear preload motor calibration has completed.

Attempting to Free a Stuck Rear Preload Motor

If the rear preload motor appears to be stuck at the maximum or minimum adjustment end stop, the function test can be used to attempt to free the motor as follows.

Warning

Never start the engine or run the engine in a confined area. Exhaust fumes are poisonous and can cause loss of consciousness and death within a short period of time. Always operate your motorcycle in the open-air or in an area with adequate ventilation.

1. Start the engine.
2. Visually Check the position of the rear preload motor as described above.

Note:

- **If the rear preload motor appears to be stuck at the minimum or maximum adjustment end stop, drive the motor away from the end stop using the appropriate test direction as follows.**
- **Motor stuck at maximum preload (adjustment collar fully extended), use the Down button.**
- **Motor stuck at minimum preload (adjustment collar fully retracted), use the Up button.**

Caution

Only use three attempts (three button clicks) at a time to attempt to free the preload motor. After using three attempts, allow the motor to cool for five minutes before making any further attempts. Failure to allow the motor to cool may cause it to overheat, which can result in permanent damage.

3. Click the **Up** or **Down** button as required to attempt to drive the rear preload motor away from the end stop. Wait for a few seconds between each button click to allow the rear preload motor time to operate.

Note:

- **If after three attempts to free the motor no adjustment collar movement can be observed, allow the motor to cool for five minutes then make three more attempts.**
4. When finished testing, click the **Next** button to proceed.
 5. The tool will automatically proceed to calibrate the rear preload motor. Follow all onscreen instructions. Refer to Appendix A - Rear Suspension Unit - Rear Preload Motor Calibration, page 12 for further information.
 6. Click **Finish** when rear preload motor calibration has completed.

Note:

- **If it is not possible to free the rear preload motor, check all motorcycle ECMs for stored DTCs.**
- **Investigate and rectify any faults as necessary then make a further attempt to free the motor as described above.**
- **If it is still not possible to free the rear preload motor, contact Triumph service.**

Please mark your copy of the Service Manual with this information. For electronic service manuals, store this information in a readily accessible place and refer to it when working on the relevant Triumph motorcycle. This information will be included in the next service manual update.