



01-18-13 - MIL ON DTC P0401 Exhaust Gas Recirculation Flow Insufficient

Release date: 11/01/2021

Condition

Applicable Vehicles					
Model(s)	Year	Eng. Code	Trans. Code	VIN Range From	VIN Range To
Jetta, Jetta Wagon	2009	2.0L TDI (CBEA)	All	All	All
Golf	2010-2014	2.0L TDI (CJAA)	All	All	All
Jetta Sedan, Jetta SportWagen, Golf Wagon	2010-2014	2.0L TDI (CJAA)	All	All	All
Beetle, Beetle Convertible	2013-2014	2.0L TDI (CJAA)	All	All	All

Revision Table			
Instance Number	Published Date	Version Number	Reason For Update
2034898/20	11/01/21	01-18-13	Update to parts table.
2034898/19	10/13/21	01-18-13	Update to parts table.
2034898/18	6/29/21	01-18-13	Update to parts table.
2034898/17	6/2/21	01-18-13	Update to text, warranty and parts table, plus additional testing attachment.
2034898/11	6/20/16	V011609	To update Golf (exchange parts) time units due to Saga/Elsa updates 6/13/16.



01-18-13 - MIL ON DTC P0401 Exhaust Gas Recirculation Flow Insufficient

Release date: 11/01/2021

Technical Background

High soot loads prior to regeneration can cause possible restrictions in the Exhaust Gas Recirculation (EGR) filter.

Tools to assist technician when checking for charge air system leaks.

Production Solution

Information only.

Service



Note:

Review TT 00-16-02 and the ELSA repair procedures, making certain to address the replacement of fasteners as indicated in the repair manual.

Required one time use items are subject to change and may not be listed.

When diagnosing a vehicle with the fault P0401 perform the following:

- Remove the EGR filter from the Diesel Particulate Filter (DPF) and swipe the inside of the exhaust pipe at the EGR filter connection point using a clean cloth or your finger. See figures 1 and 2 below.



Figure 1



Figure 2

If your finger or the cloth comes out with black soot:

- Replace the DPF & EGR filter together.
- Smoke test the charge air system for leaks (see procedure below).



01-18-13 - MIL ON DTC P0401 Exhaust Gas Recirculation Flow Insufficient

Release date: 11/01/2021



Tip:

Proper intake airflow is essential for the longevity of the DPF. If a vehicle is found to have a damaged DPF, it is advised to inspect the condition of the intake air filter and verify resting position of the warm air valve (after the vehicle has cooled, see attachment).

If there is no soot on your finger or the cloth, continue with GFF diagnostics, this bulletin does not apply.



Note:

When replacing the DPF for the fault P0401 it is important to replace both the DPF and the EGR filter together, as soot accumulation in the EGR filter is undesired. It is NOT necessary to replace any other components for this fault (i.e. NOx Storage Catalyst, Sulfur Catalyst, Exhaust Flap, EGR Cooler). These components should be reinstalled in the vehicle with the new DPF and EGR filter.

If the particulate filter was replaced, an adaptation must be performed in Guided Functions. Refer to Tech Tip TT 26-13-02 (2035501).



Note:

Vehicles with a front single assembly exhaust (one piece DPF/NOx Cat.) will require additional components. See parts table below. If the car has already had the DPF replaced once, and now has the two piece DPF/Nox Cat., there is no need for the extra parts.



Note:

Proper intake airflow is essential for the longevity of the DPF. If a vehicle is found to have a damaged DPF, it is advised to inspect the condition of the intake air filter and verify resting position of the warm air valve (after the vehicle has cooled) as outlined in “*Air Filter, Cleaning Housing and Replacing Filter Element*” section of the ELSA repair manual. Replace warm air valve (snow flap) if necessary. Additionally, any leaks within the intake air system will cause additional stress to the DPF and a reduction in engine performance. It is advised to reference TSB 21-15-06 - *Engine Lacks Performance, DTCs P2562, P2563, P2564, P2565, P2566, P0299, P20D8 or P00AF (2021771)* and follow steps 4 - 5 to ensure there are no leaks.



01-18-13 - MIL ON DTC P0401 Exhaust Gas Recirculation Flow Insufficient

Release date: 11/01/2021

Charge Air System Testing



The charge air pressure system can be checked using the VAG 1687. Charge air system tester along with the VAG1687/10 adapter as follows:

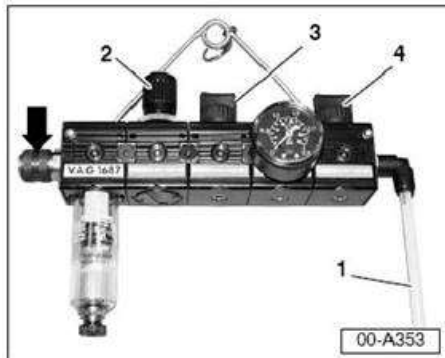

Special tool VAG 1687 Charge air system tester, preliminary set-up

- Back off pressure regulator knob -2- of VAG 1687 fully to protect gauge when shop air supply is applied to the assembly.
- Close valve -3- before gauge.
- Close valve -4- after gauge.
- Shop air supply line will later be attached to inlet of VAG 1687.
- Remove “female” fitting from tester (arrow) and install an appropriate “male” air fitting that will connect to your shop air supply line (See Note below).

Note:

Use only approved air fittings to adapt shop air supply line to VAG 1687 tester.



2.0L TDI shown

Special tool VAG 1687/10 pressure adapter, installing

On Golf, Jetta and New Beetle Models:

- Separate intake hose from the Mass Airflow Sensor assembly (MAF).
- Insert VAG 1687/10 pressure adapter in intake hose -black arrow- using existing clamp (as shown).
- Remove crankcase ventilation valve or tube from intake hose at -white arrow-.
- Plug hose with appropriate metal plug and hose clamps supplied with VAG 1687 special tool kit at -white arrow-.



01-18-13 - MIL ON DTC P0401 Exhaust Gas Recirculation Flow Insufficient

Release date: 11/01/2021



Note:

To help find small leaks, BEFORE pressurizing the system, fill system with smoke using special tool KLI9210 and adapter KLI9210/50 as outlined in this bulletin.

An Ultrasonic detector may also be used to detect extremely small leaks where smoke may not be visible.



1.8T shown

Special tool KLI9210 (EVAP system leak detector)

- Install optional fitting KLI 9210/50 on hose of special tool KLI9210.
- Connect KLI9210 to VAG 1687/1 adapter (KLI 9210 is shown attached to VAG1687/1 at arrow on 1.8L Turbo).

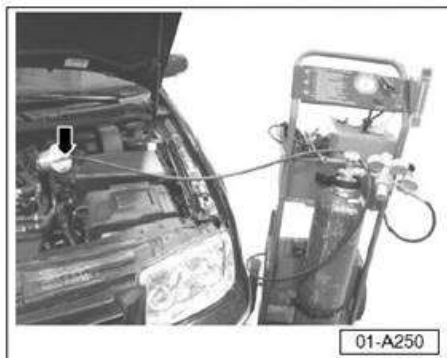

Special tool KLI9210 (EVAP system leak detector)

- Install optional fitting KLI 9210/50 on hose of special tool KLI9210.
- Connect KLI9210 to VAG 1687/1 adapter (KLI 9210 is shown attached to VAG1687/1 at arrow on 1.8L Turbo).

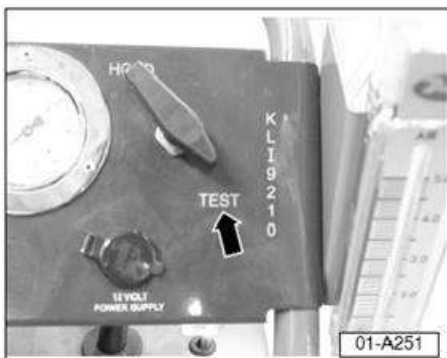

Special tool KLI9210 (EVAP system leakdetector),

preliminary set-up

- Setup KLI 9210 as described in user manual regarding self-test and output pressure.
- Connect smoke generator leads to vehicle battery.
- Turn valve to test (black arrow).
- Press smoke generator button to fill system with smoke (see instructions printed on tester).
- Check for escaping smoke for two minutes.



01-18-13 - MIL ON DTC P0401 Exhaust Gas Recirculation Flow Insufficient

Release date: 11/01/2021



Tip:

Smoke may escape from crankcase hose or oil fill hole. This is normal.

With system filled with smoke:

- Remove smoke generator hose and connect VAG 1687 quickly to prevent smoke from leaking out.



- Connect VAG 1687 quickly to prevent smoke from leaking out.

Special tool VAG 1687 connecting to pressure adapter 1687/10

VAG 1687 is shown connected to VAG 1687/10 (black arrow)
Shop air supply connected to VAG 1687 at (white arrow).

- Perform pressure test.

1.8T Shown

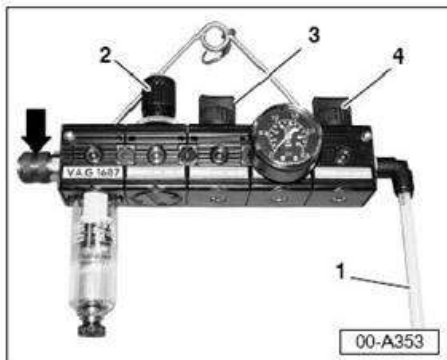

Performing pressure Test:

- With outlet hose -1- of VAG 1687 connected to air pressure adapter.
- Attach shop air supply line to previously installed male fitting.



01-18-13 - MIL ON DTC P0401 Exhaust Gas Recirculation Flow Insufficient

Release date: 11/01/2021

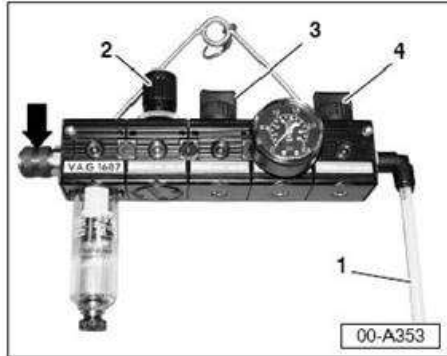

- Open valve -3- between regulator valve and gauge.
- Adjust test pressure up to 0.5 bar (see Note below) by turning the regulator valve -2-.



Note:

DO NOT pressurize system above 0.5bar.

Doing so may force oil into the intake system which can damage the engine.

- Slowly open outlet valve -4- (after gauge) to test hose connections.

Observe pressure gauge for a drop in pressure.



Tip:

Some pressure will be lost past the throttle plate.

If smoke generator was used to fill the system with smoke:

- Check for smoke escaping from intake connections.



Tip:

An Ultrasonic detector may also be used to detect extremely small leaks where smoke may not be visible.

- Repair any leaks found.
- Remove tester.
- Remove plug from crankcase ventilation hose.
- Remove air pressure adapter.
- With VAS diagnostic tool connected:
 - Erase DTC memory.

If smoke generator was not used to fill the system with smoke:

- Apply soapy water solution or equivalent to intake system connections.



Tip:

An Ultrasonic detector may also be used to detect extremely small leaks.

- Inspect intake system connections for leaks.
- Repair any leaks found.
- Remove tester.



01-18-13 - MIL ON DTC P0401 Exhaust Gas Recirculation Flow Insufficient

Release date: 11/01/2021

- Remove plug from crankcase ventilation hose.
- Remove air pressure adapter.

With VAS diagnostic tool connected:

- Erase DTC memory.

If no leaks are found, but complaint still exists, refer to Repair Group 21 in Elsa for detailed testing of charge system components.

Warranty

To determine if this procedure is covered under Warranty, always refer to the Warranty Policies and Procedures Manual ¹⁾					
Model(s)	Year(s)	Eng. Code(s)	Trans. Code(s)	VIN Range From	VIN Range To
Jetta, Jetta Wagon	2009	2.0L TDI (CBEA)	All	All	All
Golf	2010-2014	2.0L TDI (CJAA)	All	All	All
Jetta Sedan, Jetta SportWagen, Golf Wagon	2010-2014	2.0L TDI (CJAA)	All	All	All
Beetle, Beetle Convertible	2013-2014	2.0L TDI (CJAA)	All	All	All
SAGA Coding					
Claim Type:		Use applicable Claim Type ¹⁾			
Service Number:	Damage Code	HST		--	
2674	0010	--		--	
Parts Manufacturer		Golf		WWO ²⁾	
		Jetta, Jetta SportWagen, Beetle, Beetle Convertible		3ME ²⁾	



01-18-13 - MIL ON DTC P0401 Exhaust Gas Recirculation Flow Insufficient

Release date: 11/01/2021

2009 Jetta (CBEA)	
Labor Operation ³⁾ : Remove and Install Particle Filter (Includes EGR Filter Replacement)	26741933 = see Elsa for latest time units.
Labor Operation ³⁾ : Exchange components between original and replacement Particulate Filter	26745581 = see Elsa for latest time units.
Labor Operation ³⁾ : Check Warm Air Valve (Snow Flap) operation, no further action required.	23252599 = 10 TU
Labor Operation ³⁾ : Install new Warm Air Valve (Snow Flap)	23252599 = 30 TU
Labor Operation ³⁾ : Smoke Test	21412599 = 70 TU
Jetta Wagon (CBEA), 2009 Jetta, Jetta Wagon (CJAA)	
Labor Operation ³⁾ : Remove and Install Particle Filter (Includes EGR Filter Replacement)	26741931 = see Elsa for latest time units.
Labor Operation ³⁾ : Exchange components between original and replacement Particulate Filter	26745581 = see Elsa for latest time units.
Labor Operation ³⁾ : Check Warm Air Valve (Snow Flap) operation, no further action required.	23252599 = 10 TU
Labor Operation ³⁾ : Install new Warm Air Valve (Snow Flap)	23252599 = 30 TU
Labor Operation ³⁾ : Smoke Test	21412599 = 70 TU
2010-2014 Golf (CJAA)	
Labor Operation ³⁾ : Remove and Install Particle Filter (Includes EGR Filter Replacement)	26741931 = see Elsa for latest time units.
Labor Operation ³⁾ : Exchange components between original and replacement Particulate Filter	26745581 = see Elsa for latest time units.
Labor Operation ³⁾ : Check Warm Air Valve (Snow Flap) operation, no further action required.	23252599 = 10 TU
Labor Operation ³⁾ : Install new Warm Air Valve (Snow Flap)	23252599 = 30 TU



01-18-13 - MIL ON DTC P0401 Exhaust Gas Recirculation Flow Insufficient

Release date: 11/01/2021

Labor Operation ³⁾ : Smoke Test	21412599 = 70 TU
2010-2014 Jetta, Jetta SportWagen (CJAA)	
Labor Operation ³⁾ : Remove and Install Particle Filter (Includes EGR Filter Replacement)	26741931 = see Elsa for latest time units.
Labor Operation ³⁾ : Exchange components between original and replacement Particulate Filter	26745581 = see Elsa for latest time units.
Labor Operation ³⁾ : Check Warm Air Valve (Snow Flap) operation, no further action required.	23252599 = 10 TU
Labor Operation ³⁾ : Install new Warm Air Valve (Snow Flap)	23252599 = 30 TU
Labor Operation ³⁾ : Smoke Test	21412599 = 70 TU
2013-2014 Beetle (CJAA)	
Labor Operation ³⁾ : Remove and Install Particle Filter (Includes EGR Filter Replacement)	26741933 = see Elsa for latest time units.
Labor Operation ³⁾ : Exchange components between original and replacement Particulate Filter	26745581 = see Elsa for latest time units.
Labor Operation ³⁾ : Check Warm Air Valve (Snow Flap) operation, no further action required.	23252599 = 10 TU
Labor Operation ³⁾ : Install new Warm Air Valve (Snow Flap)	23252599 = 30 TU
Labor Operation ³⁾ : Smoke Test	21412599 = 70 TU
2013-2014 Beetle Convertible (CJAA)	
Labor Operation ³⁾ : Remove and Install Particle Filter (Includes EGR Filter Replacement)	26741933 = see Elsa for latest time units.
Labor Operation ³⁾ : Exchange components between original and replacement Particulate Filter	26745581 = see Elsa for latest time units.
Labor Operation ³⁾ : Check Warm Air Valve (Snow Flap) operation, no further action required.	23252599 = 10 TU



Technical Service Bulletin

Transaction No: 2034898/20

01-18-13 - MIL ON DTC P0401 Exhaust Gas Recirculation Flow Insufficient

Release date: 11/01/2021

Labor Operation ³⁾ : Install new Warm Air Valve (Snow Flap)	23252599 = 30 TU	
Labor Operation ³⁾ : Smoke Test	21412599 = 70 TU	
Causal Part:	1K0 254 708 GX	
Outside Material: Freeze Spray (obtained locally)	\$1.00 (1 can tests 15 vehicles)	
Diagnostic Time ⁴⁾		
GFF Time expenditure	01500000 = 30 TU max.	YES
Road Test	01210002 = 00 TU 01210004 = 00 TU	NO
Technical Diagnosis	01320000 = 30 TU max.	YES
Claim Comment: Input "As per Technical Bulletin 2034898" in comment section of Warranty Claim.		
<p>¹⁾ Vehicle may be outside any Warranty in which case this Technical Bulletin is informational only</p> <p>²⁾ Code per warranty vendor code policy.</p> <p>³⁾ Labor Time Units (TUs) are subject to change with ELSA updates.</p> <p>⁴⁾ Documentation required per Warranty Policies and Procedures Manual.</p>		

Required Parts and Tools

MY 2009 Replacement of 1 piece system:

Part No:	Part Description	Quantity
1K0 254 708 GX	DPF	1
1K0 254 402 AX	NOx Catalyst	1
1K0 254 401 R	Sulfur Catalyst	1
1K0 253 115 AE	Seal	3
1K0 131 649	Bracket	1
1K0 253 725	Clamp	2



01-18-13 - MIL ON DTC P0401 Exhaust Gas Recirculation Flow Insufficient

Release date: 11/01/2021

1K0 253 725 B	Clamp	2
1K0 253 120 B	EGR Filter	1
1K0 253 725 E	Clamp	1
1K0 253 115 AG	Gasket	1
1K0 253 115 T	Gasket	1
03G 131 547 H	Gasket	1
3C0 129 594 E	Control Valve (Snow Flap)	1

Part numbers are accurate at time of publication. Always refer to ETKA for the latest part information.

MY2009, MY2010-2014 Replacement of 2 piece system

Part No:	Part Description	Quantity
1K0 254 708 GX	DPF	1
1K0 253 115 AE	Seal	2
1K0 253 725	Clamp	2
1K0 253 725 B	Clamp	1
1K0 253 120 B	EGR Filter	1
1K0 253 115 AG	Gasket	1
1K0 253 115 T	Gasket	1
1K0 253 725 E	Clamp	1
03G 131 547 H	Gasket	1
3C0 129 594 E	Control Valve (Snow Flap)	1
N 105 797 02	Bolt	3
N 912 084 01	Bolt	4



01-18-13 - MIL ON DTC P0401 Exhaust Gas Recirculation Flow Insufficient

Release date: 11/01/2021

N 911 433 01	Bolt	2
N 911 671 01	Bolt	1
N 910 661 01	Bolt	1
WHT 005 350	Escutcheon	2
WHT 000 729 A	Bolt	3
WHT 000 431 A	Bolt	2
N 910 398 02	Bolt	3
1K0 825 951	Bolt	3

Part numbers are accurate at time of publication. Always refer to ETKA for the latest part information.

Tool Description	Tool No:
Freeze Spray	Obtained locally
Charge Air System Tester Kit	VAG 1687*
EVAP System Leak Detector	KLI9210*
Midtronics Battery Tester/Charger	InCharge 940 (INC-940) or GRX3000VAS
VAS Diagnostic Tool	VAS 6150/X & VAS 6160/X and ODIS Service with: current online updates

Additional Information

All part and service references provided in this Technical Bulletin are subject to change and/or removal. Always check with your Parts Dept. and Repair Manuals for the latest information.

Checking changeover valve for intake air preheating

Note

Test should be performed after vehicle has cooled.

Special tools and workshop equipment required

- ◆ Freeze spray (obtained locally)
- ◆ Torque screwdriver -VAS 6494-

Check changeover valve for intake air preheating:



- Unscrew bolts -arrows- from air filter housing upper section.

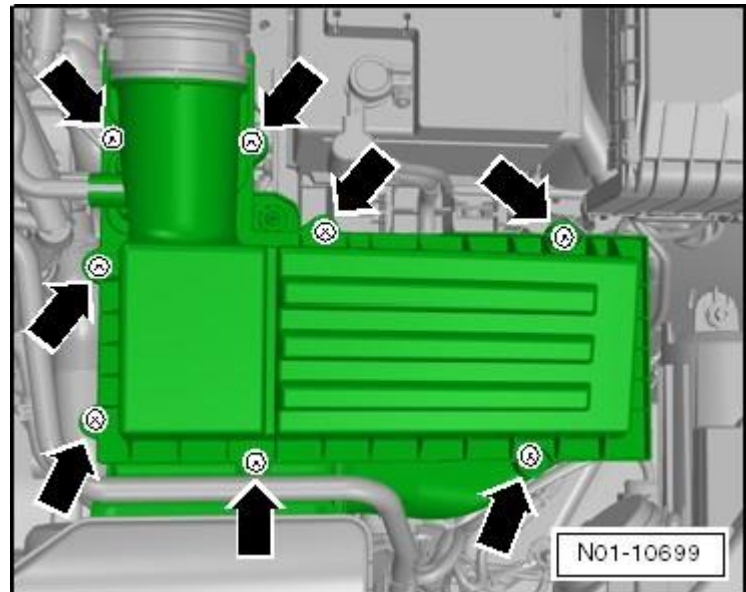

- Raise air filter upper section and remove airfilter element -1-.
Inspect air filter and if too contaminated with debris, advise customer to replace (non-warranty claimable item).

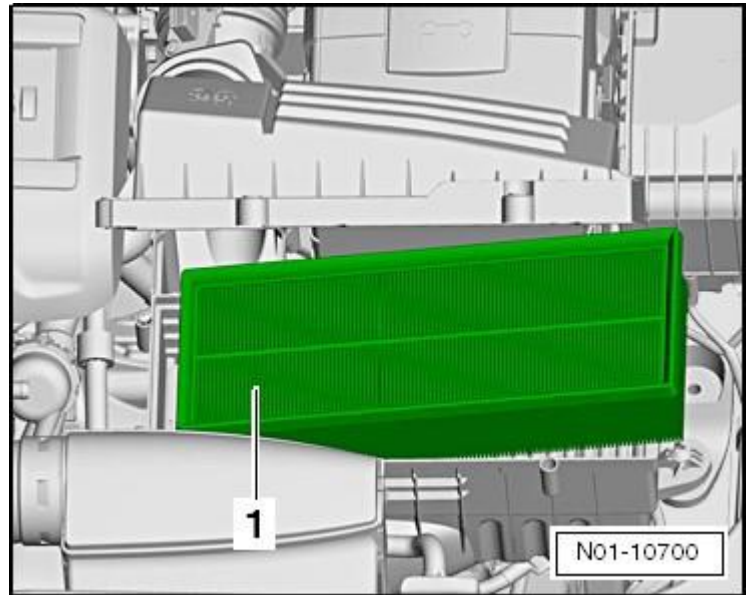

- Remove snow screen.
- Spray freeze spray (lower arrow) onto the thermal element until the flap opens (upper arrow). If it does not open, replace flap.
- After the flap opens wait for 15 minutes. If the flap is not completely closed after that time replace the flap.



Note

The changeover valve for intake air preheating opens and closes with a slight delay as the expansion element first needs to cool down or warm up.

