

October 26, 2021

Version 1

MIL Comes On with DTC P1F86 at Startup

AFFECTED VEHICLES

Year	Model	Trim Level	VIN Range
2019–20	Clarity Fuel Cell	ALL	ALL
2021	Clarity Fuel Cell	ALL	JHMZC4...MC000001 - JHMZC4...MC000354

SYMPTOM

The MIL comes on with DTC P1F86 FC Cell Voltage Too Low (Caution).

POSSIBLE CAUSE

Fuel cell stack deterioration.

CORRECTIVE ACTION

Replace the FC stack, FC ion exchanger filter, and update the fuel cell system software.

PARTS INFORMATION

Part Name	Part Number	Quantity
Fuel Cell Stack	3A100-5WM-A50 (2019) 3A100-5WM-A61 (2020-21)	1
Stack Kit	063A0-5WM-305	1
Ion Filter	3H450-5WM-A01	1

These controlled parts require the VIN of an affected vehicle to place an order.

REQUIRED MATERIALS

Part Name	Part Number	Quantity
Antifreeze/Coolant	OL999-9011	2
Honda Genuine Fuel Cell Insulating Fluid - 50% Prediluted Formulation	OL999-9014	2

CUSTOMER INFORMATION: The information in this bulletin is intended for use only by skilled technicians who have the proper tools, equipment, and training to correctly and safely maintain your vehicle. These procedures should not be attempted by “do-it-yourselfers,” and you should not assume this bulletin applies to your vehicle, or that your vehicle has the condition described. To determine whether this information applies, contact an authorized Honda automobile dealer.

TOOL INFORMATION

Tool Name	Tool Number	Quantity
Universal Lifting Eyelet	07AAK-SNAA129	1
Oil Filter Wrench	07HAA-PJ70101	1
Transmission Hanger Bracket (This tool is not included in the required tools cabinet. Order one only if needed.)	21232-RCT-A00	1

WARRANTY CLAIM INFORMATION

The normal warranty applies.

2019 Clarity

Operation Number	Description	Flat Rate Time	Defect Code	Symptom Code	Template ID	Failed Part Number
3101CK	Replace the Fuel Stack and Ion Filter – (Includes control unit update)	11.2 hr.	03214	03217	A21084A	3A100-5WM-A50
3120A0	Venting (Clarity FC)	1.7 hr.				
A	If tank is two thirds full - Add	1.0 hr.			A21084B	
B	If tank is completely full – Add (A&B)	1.0 hr.			A21084C	

2020-21 Clarity

Operation Number	Description	Flat Rate Time	Defect Code	Symptom Code	Template ID	Failed Part Number
3101CK	Replace the Fuel Stack and Ion Filter – (Includes control unit update)	11.2 hr.	03214	03217	A21084D	3A100-5WM-A61
3120A0	Venting (Clarity FC)	1.7 hr.				
A	If tank is two thirds full - Add	1.0 hr.			A21084E	
B	If tank is completely full – Add (A&B)	1.0 hr.			A21084F	

Skill Level: Fuel Cell Certified Technician

NOTE: Make sure you indicate the VIN, mileage, and date on the replaced part and its box.

⚠ WARNING

Failure to properly vent the hydrogen tanks and fuel lines prior to the fuel cell stack replacement can result in hydrogen gas leaks.

Hydrogen gas is flammable and highly explosive. You can be seriously injured or killed if the leaking hydrogen gas is ignited.

Turn off the fuel cell system, and keep heat, sparks, and flames away.

Always follow the precautions for the fuel cell system listed in the service information.

The power cables carry high voltage when the fuel cell system is energized. To avoid serious injury from electrical shock, do not turn on the system with the power cables disconnected.

NOTE:

- When working on or around the fuel cell system, pay attention to the service precautions for the fuel cell system.
- Refer to the job aid *Fuel Cell Service Equipment Kit and Portable Vent Stack* for proper use of the venting equipment.

1. Replace the fuel cell stack as described in the service information system (SIS). Rotate the tires during the repair.

NOTE: Click [HERE](#) to watch a video on FC stack and FC ion exchanger removal.

2. Reset the maintenance minder (A1) using the i-HDS.

NOTE:

- If you are unable to successfully reset the maintenance minder, turn the ignition to OFF and wait 10 minutes after the air pump unit has stopped.
- After turning the ignition to OFF, the air pump unit will continue to operate for a minute or less (it may be longer in low temperatures) and shutoff automatically. Once the air pump unit stops, wait at least 10 minutes to start the maintenance minder reset procedure.
- To check if the air pump unit is running, go to the back of the vehicle and check the diluter (exhaust pipe outlet). You should hear and feel air coming out of it. Once you stop hearing and feeling the air, the air pump unit has stopped.

Preparing the Vehicle Requiring an FC Stack

3. Vent the hydrogen to **4000 kPa** pressure to prepare for the new (donor) FC stack installation. Refer to the service information procedure, Preparation Before Component Removal and do the steps listed under Common Procedures and Procedure A.
4. Once the venting is complete, move the vehicle inside and onto a lift.
5. Remove both front wheels.
6. Remove the motor undercover and front floor undercover.

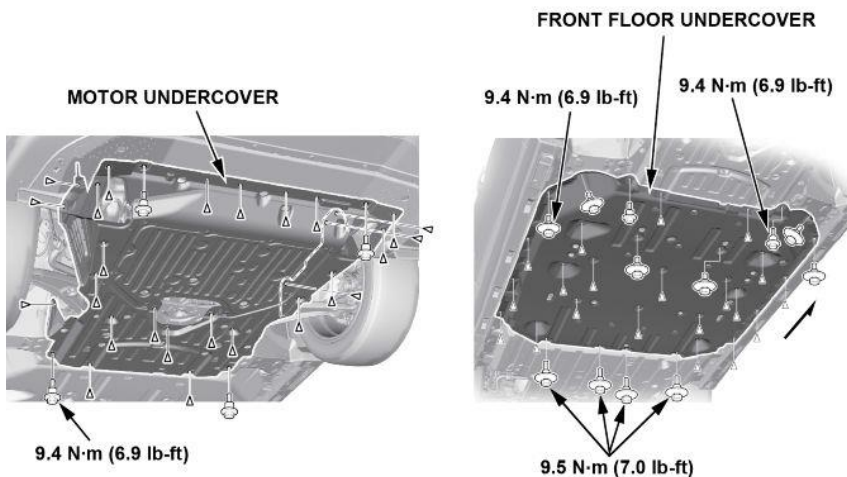

7. Remove the FC radiator expansion tank cap, and drain the FC insulating fluid.

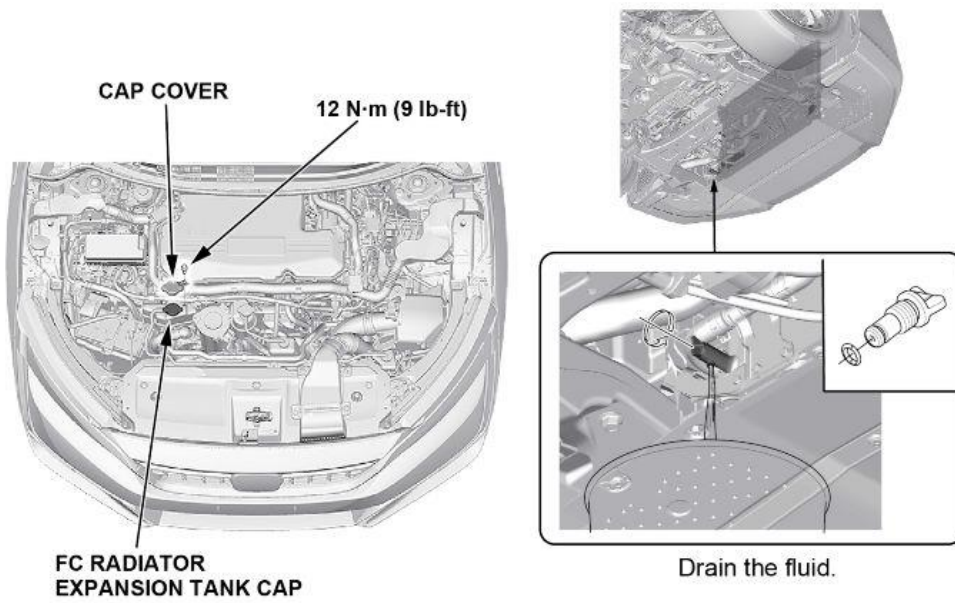

8. Remove the DT radiator expansion tank cap and drain the DT coolant.

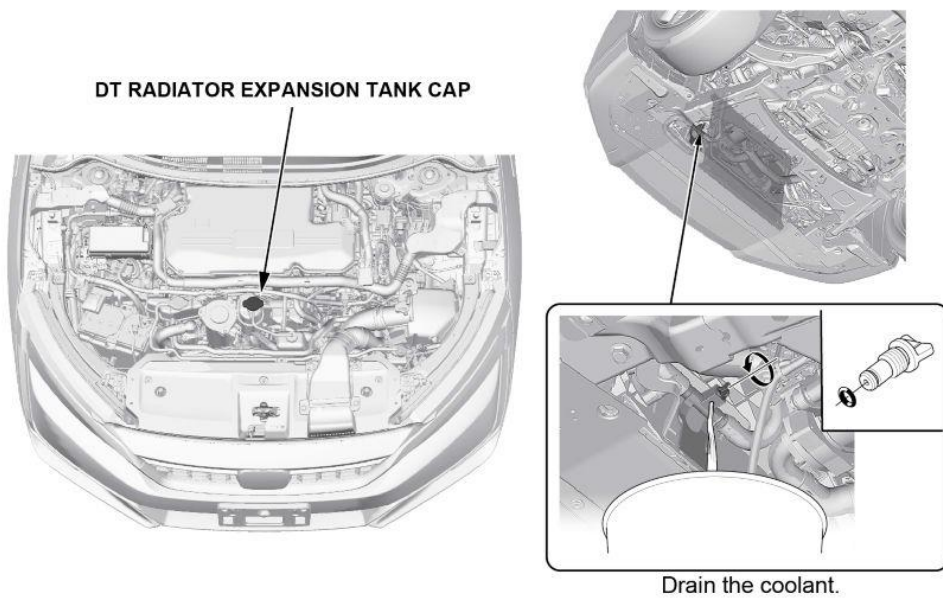

9. Disconnect both hydrogen sensor connectors. **Do not remove the sensor** from the ventilation duct A.

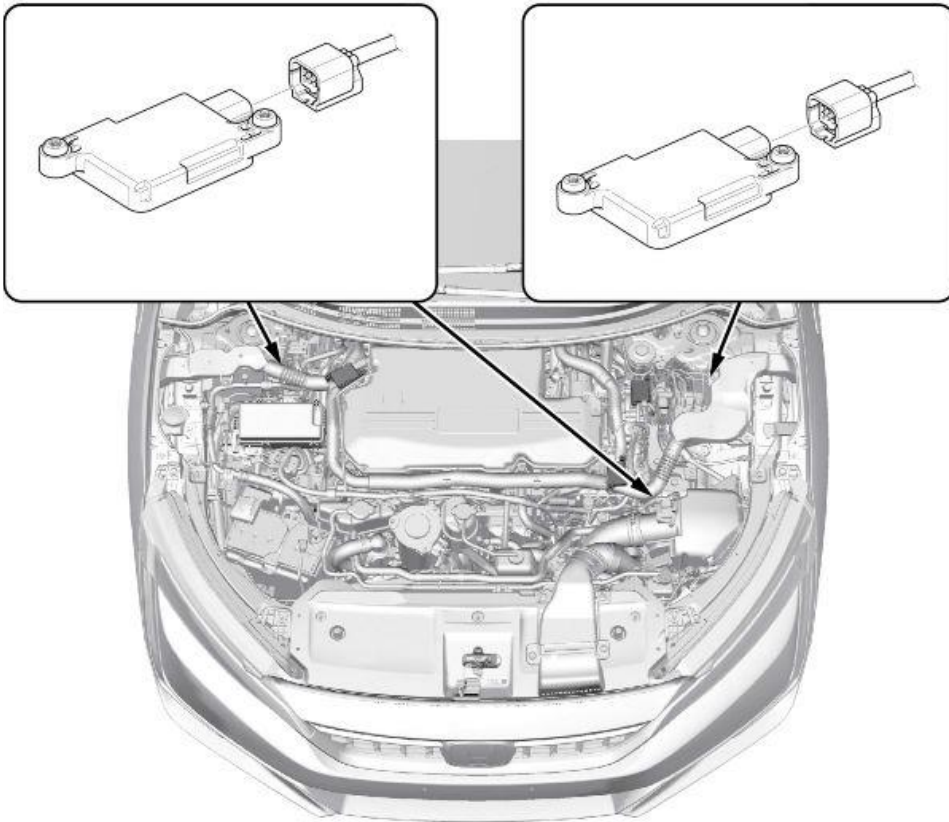

10. Remove FC ventilation duct A as an assembly as shown.

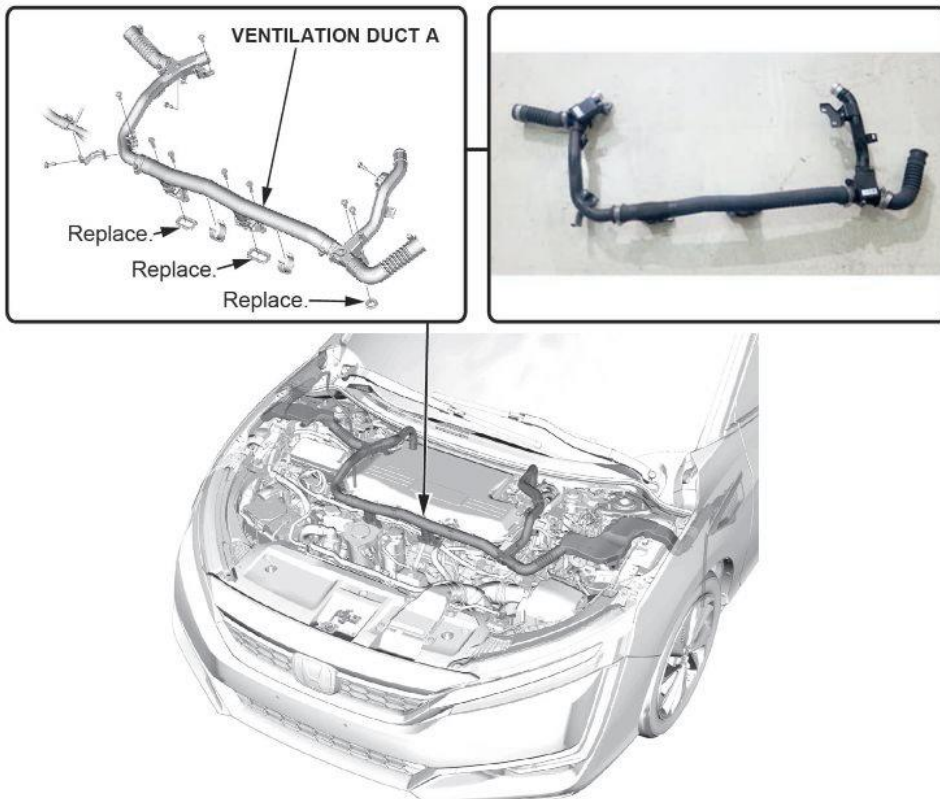

11. Remove the windshield wiper arms.

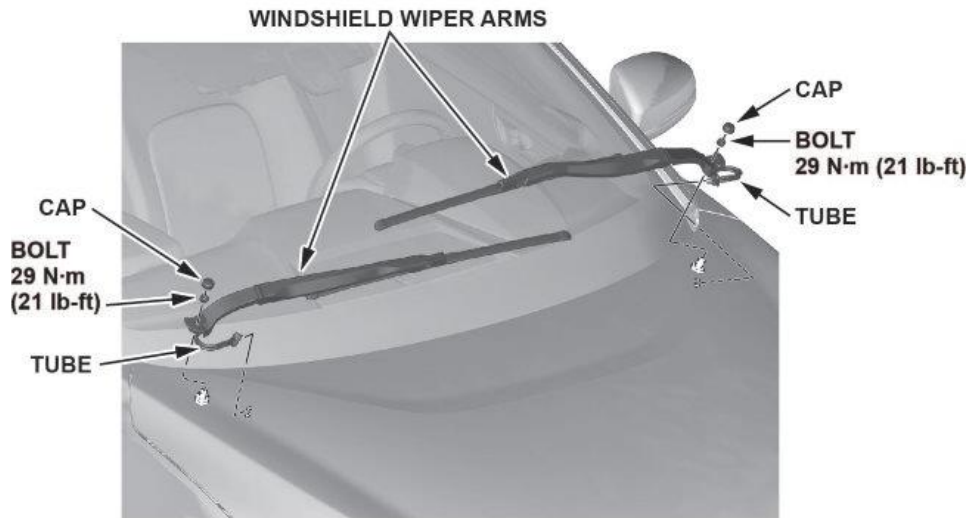

12. Remove the cowl cover.



13. Remove the cowl cover under lid.

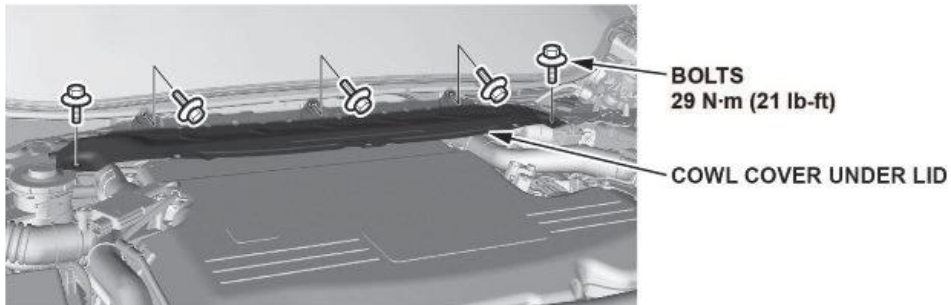

14. Access the service plug by pulling back the carpet located under the back side of the center console, then remove the service plug hole cap and service plug hole lid.

NOTE: Reuse the service plug hole lid if the seal is not deformed or damaged.

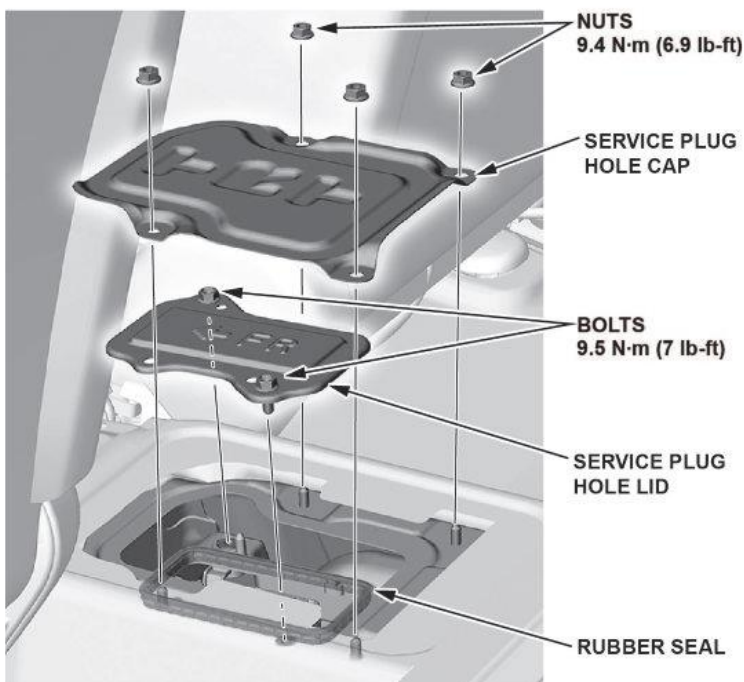

15. Raise the lever while pushing and sliding the tab in the direction of the arrow.

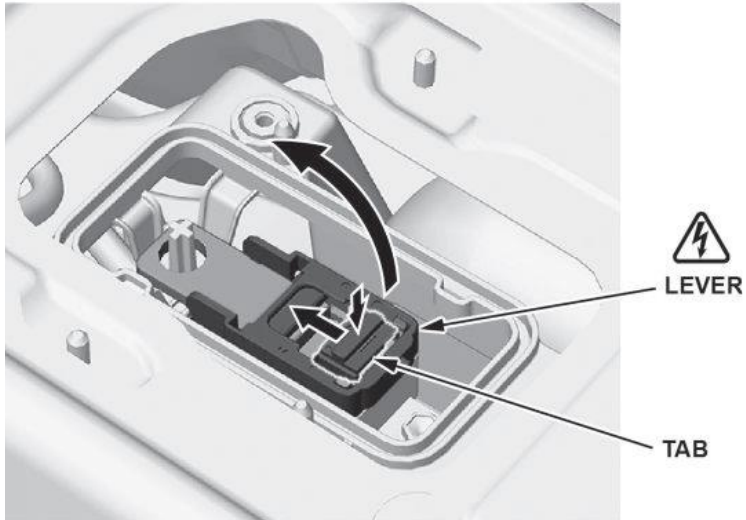

16. Remove the service plug.

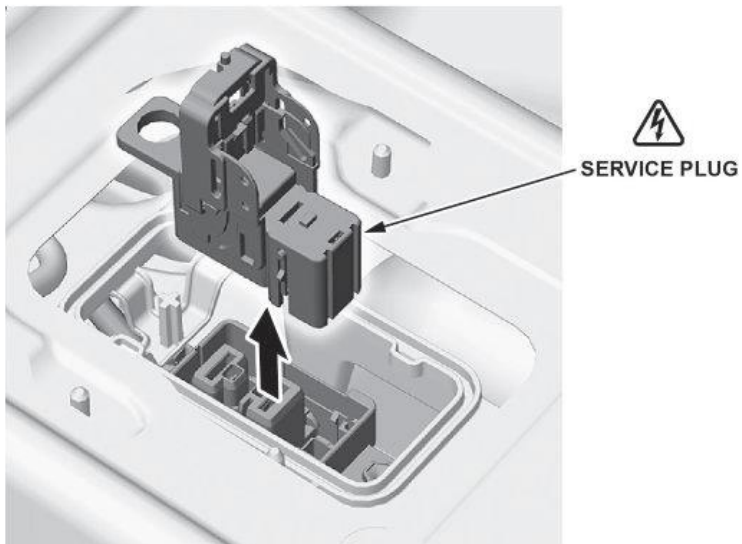

17. Wrap the service plug base with insulating tape.

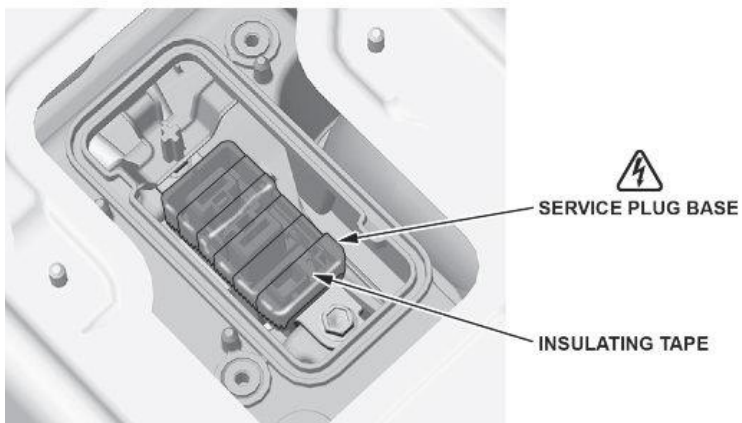

18. Disconnect the FC VCU power cable.

NOTE: Wrap insulating tape or a clean shop towel around the connector to prevent oil, water, or dirt from entering.

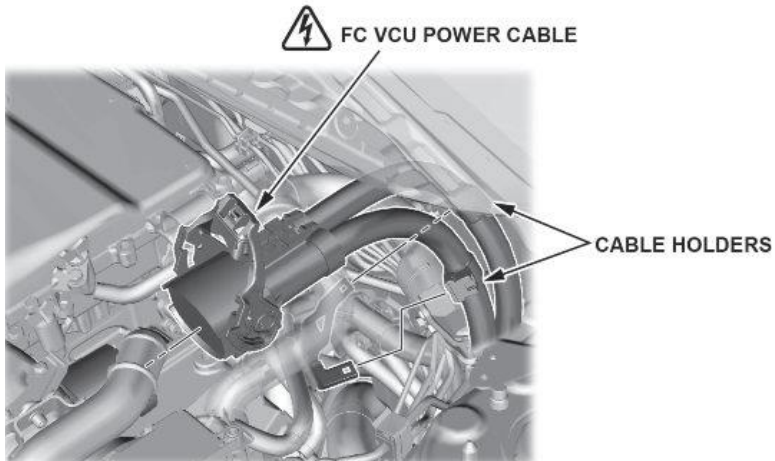

19. Remove the left and right FC stack power cable cover.

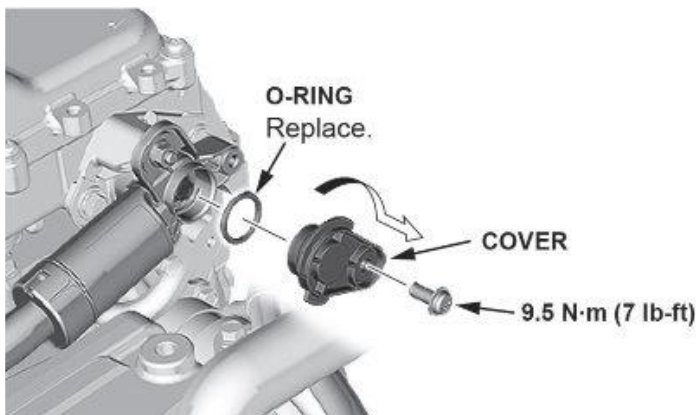

20. Measure the voltage of the FC VCU by connecting a multimeter to both the right and left terminal. Make sure to wait for the voltage to be **30-volts** or less before continuing.

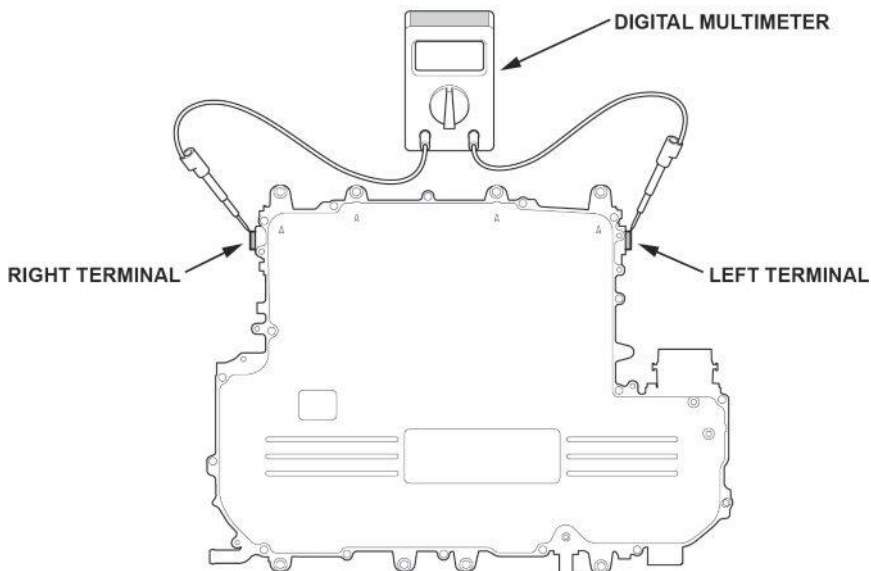

21. Remove the VCU. Refer to the service information system (SIS) for additional information.

All bracket bolts: 12 N·m (9 lb-ft)

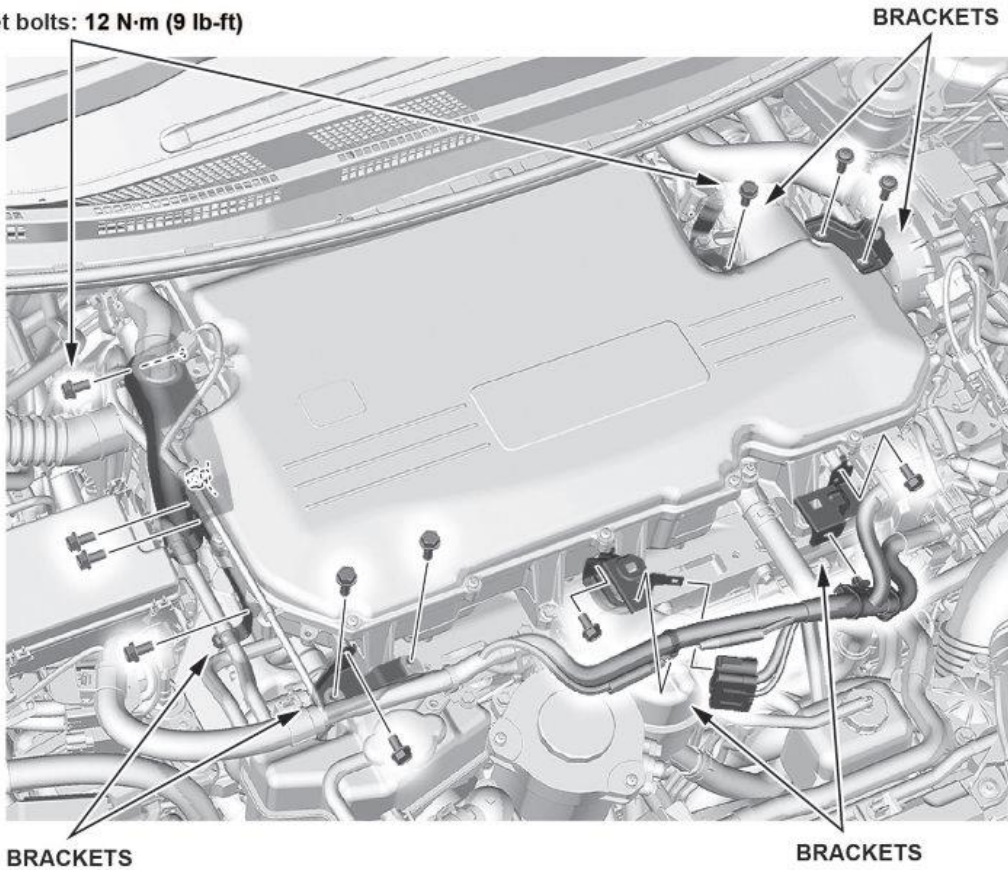

11 N·m (8 lb-ft)

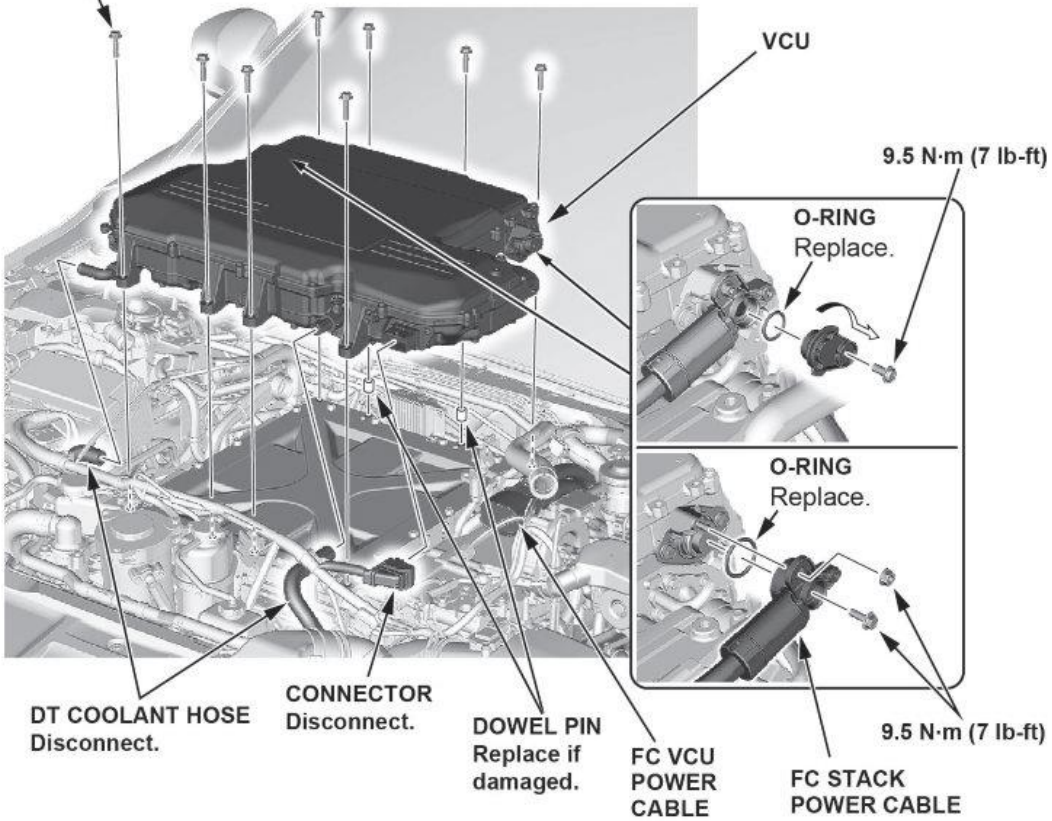

NOTE: The marks located on the back of the FC VCU show which bolts to remove.

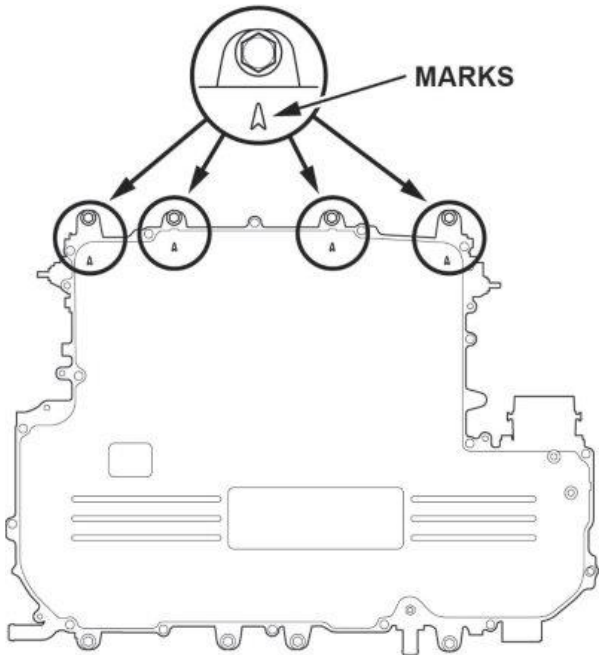

22. Remove the thermostat.

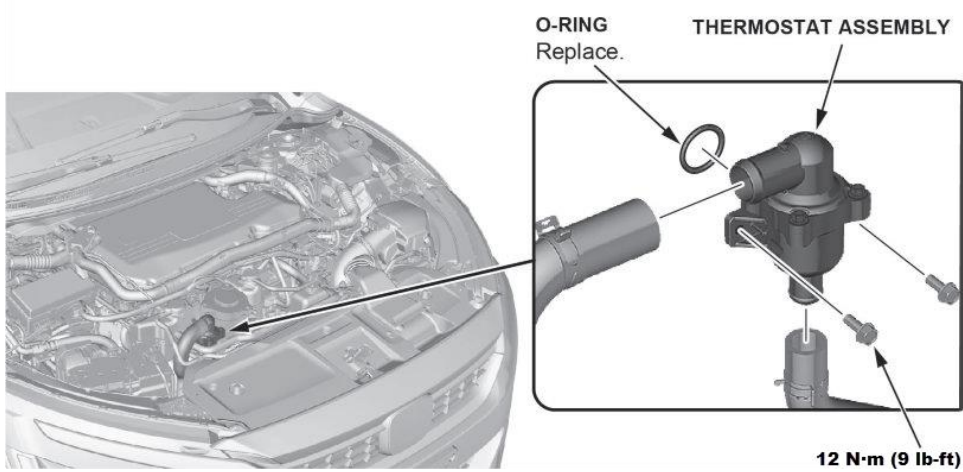

23. Remove the FC ion exchanger.

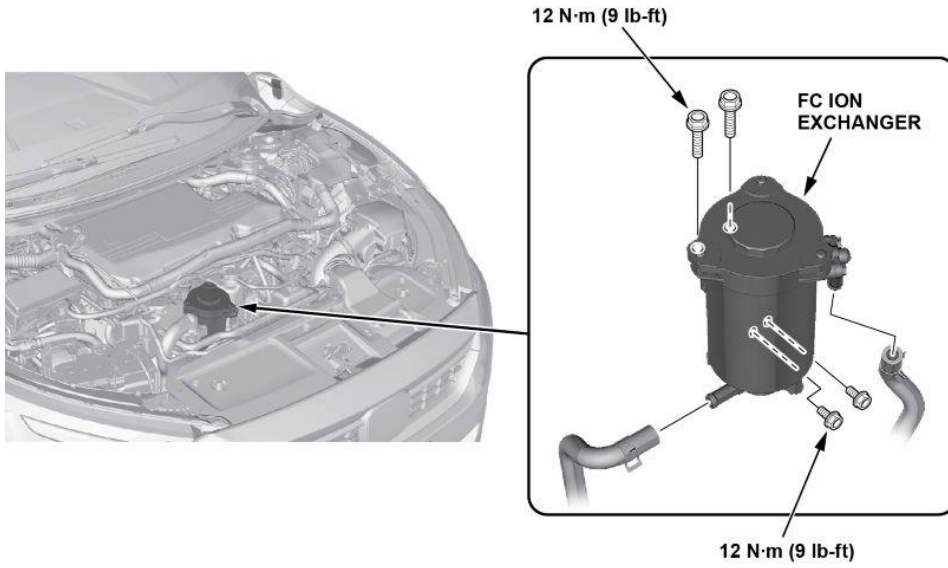

24. Remove the DT radiator expansion tank.

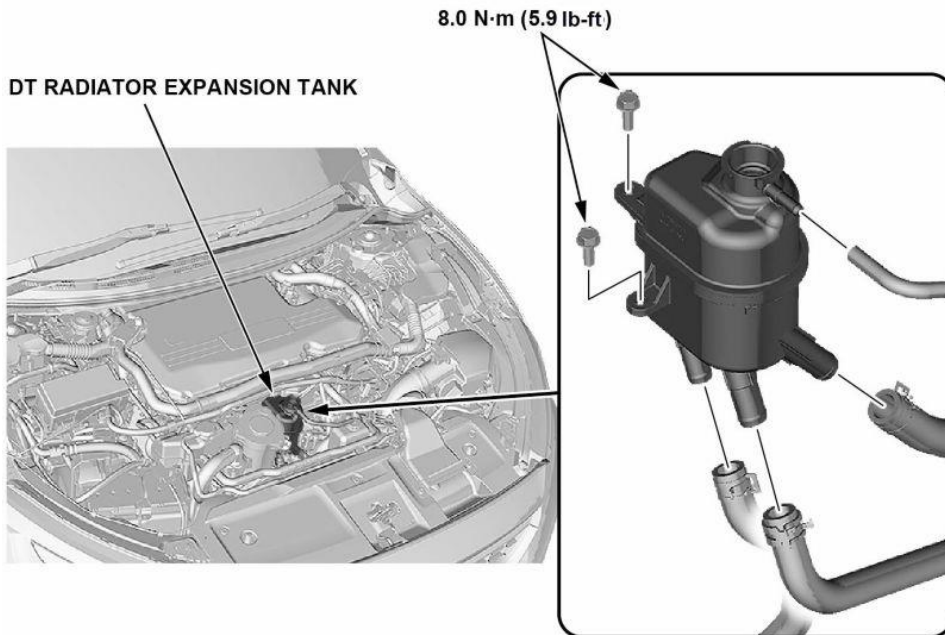

25. Remove the FC radiator expansion tank.

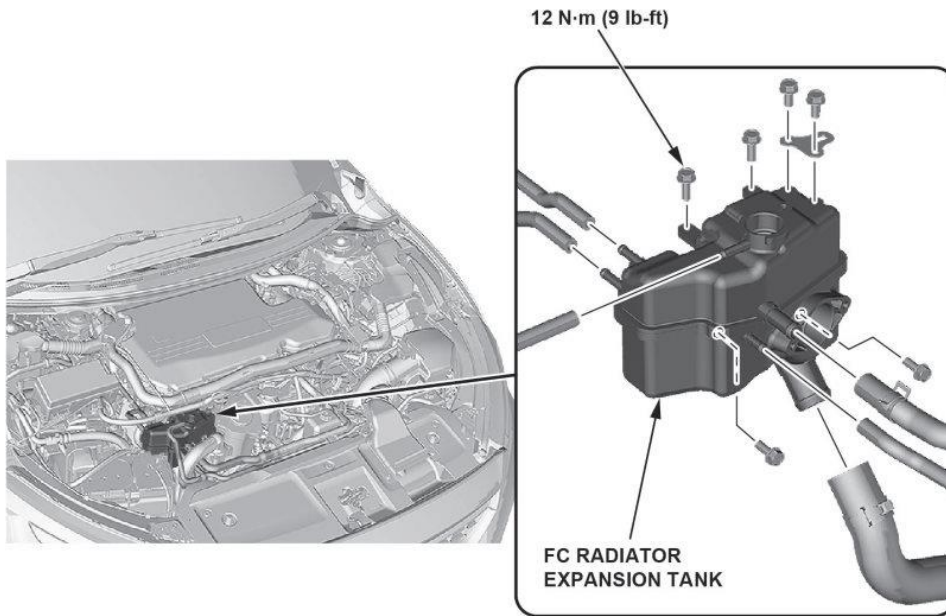

26. Remove the air pump intake duct (air cleaner duct).

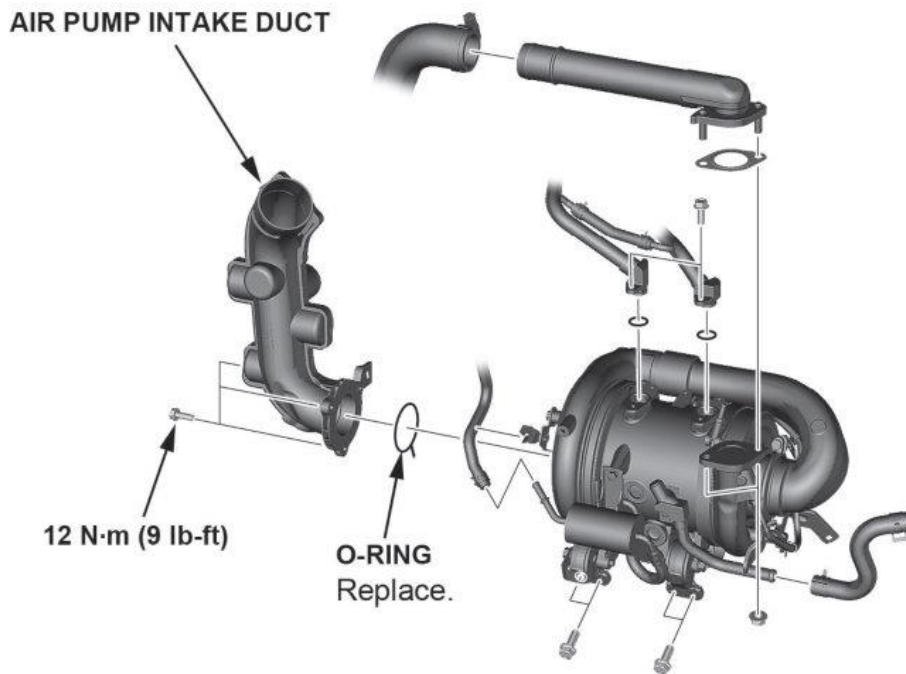

27. Disconnect the FC radiator inlet fluid temperature sensor connector. **Do not remove the sensor.**

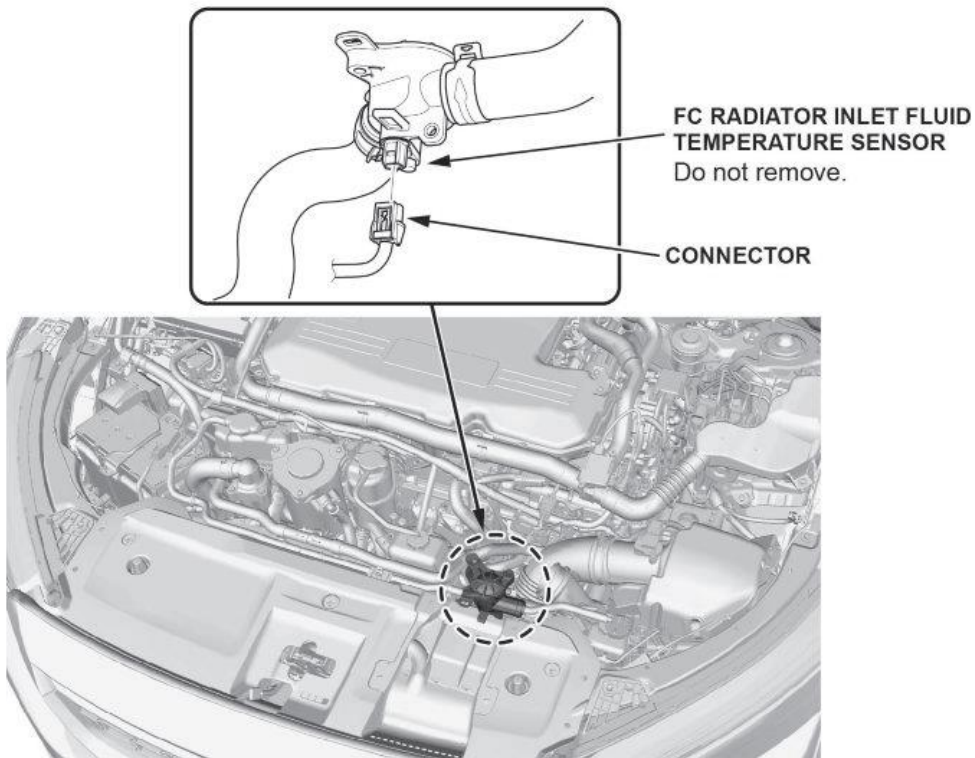

28. Disconnect the FC stack outlet fluid temperature sensor connector. **Do not remove the sensor.**

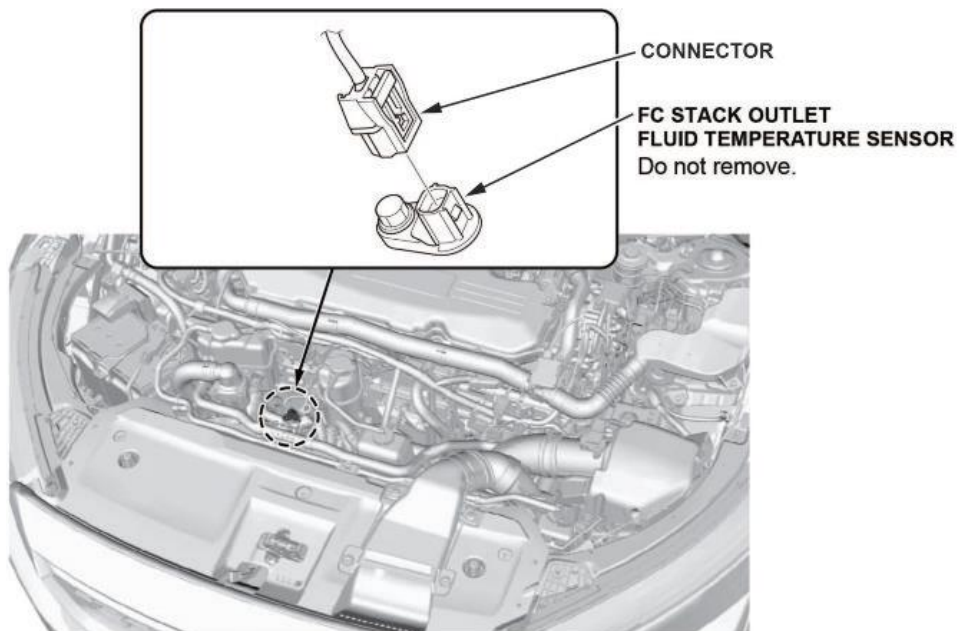

29. Remove the parts surrounding the FC stack.

NOTE: This procedure will not require the removal of the FC ECU. **Do not** remove the FC ECU from the FC stack.

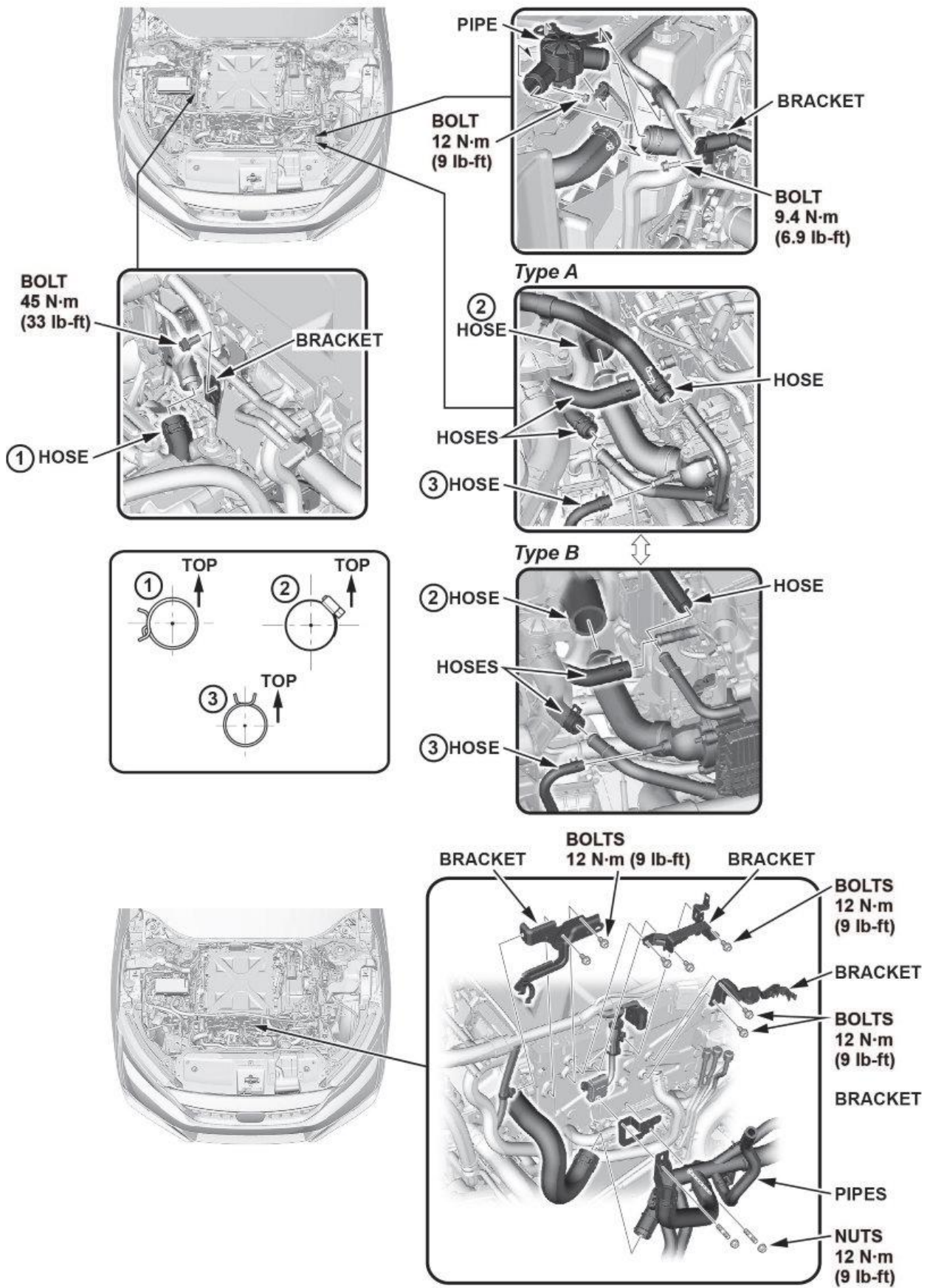

30. Disconnect the FC wire harness.

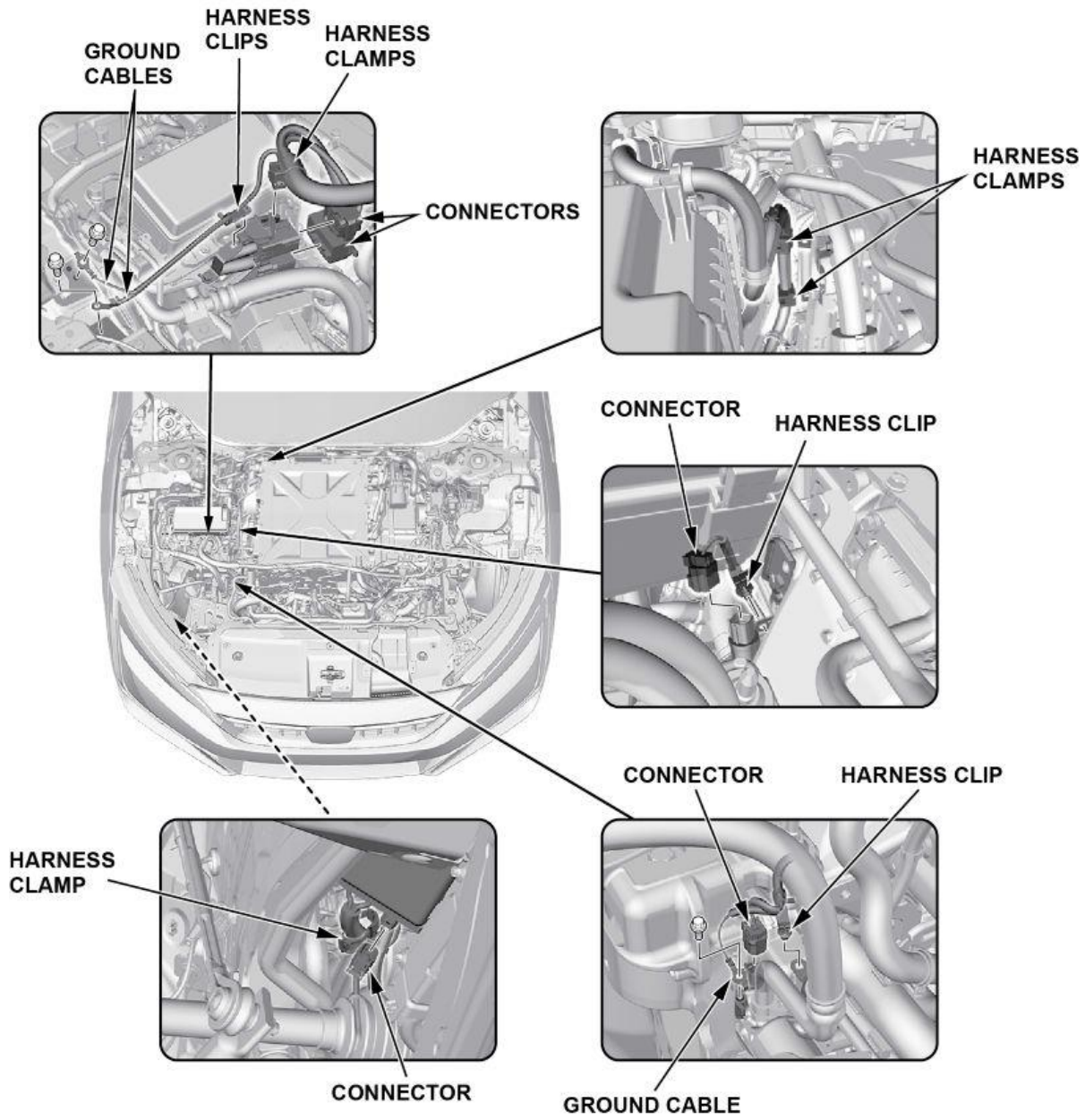

31. Remove the electric coolant heater from the FC stack, but do not remove bracket A. Once the heater is removed, place it out of the way on the frame.

NOTE: You do not need to remove the hoses from the heater, only the electrical connection.

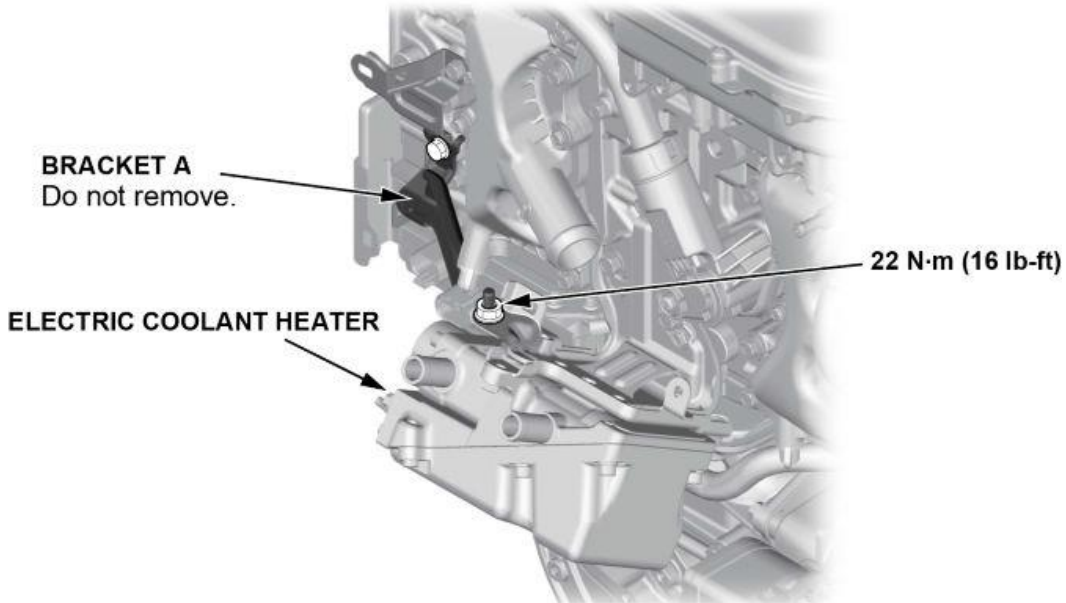

32. Remove the harness clips.

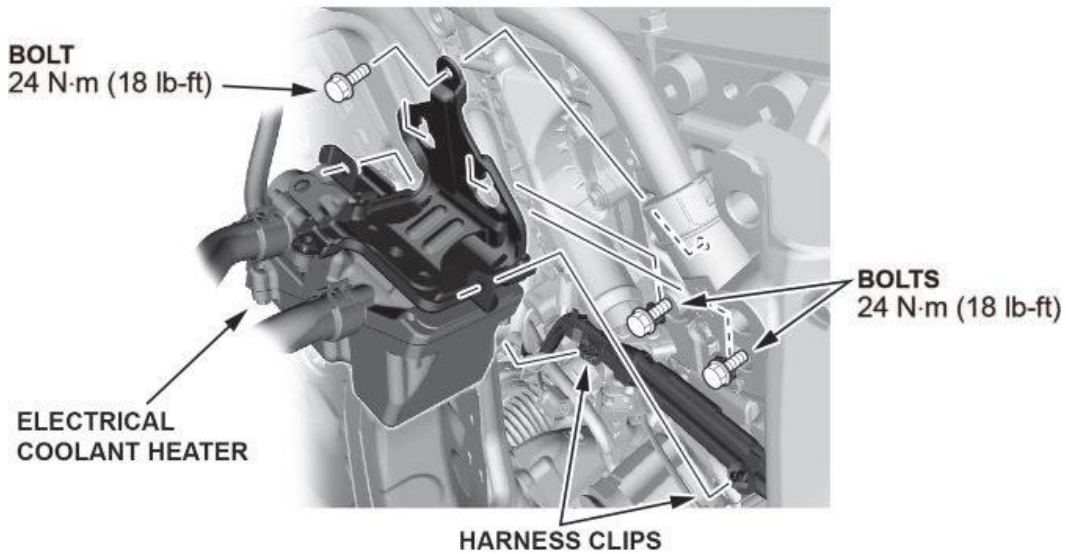

33. Remove the bolts.

34. Disconnect the harness connector from the heater.

35. Loosen and disconnect, but do not remove exhaust hose A from the FC stack outlet.

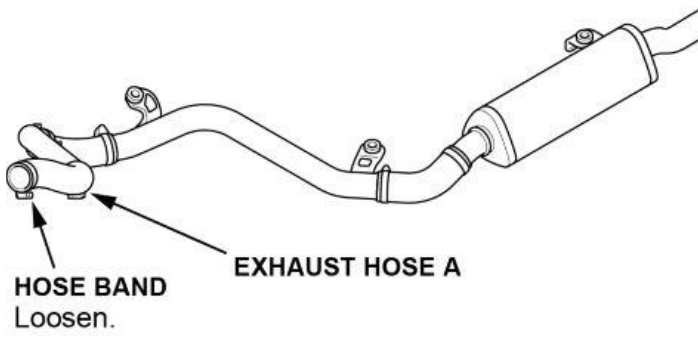

36. Disconnect the cooling air outlet hose from the air pump unit.

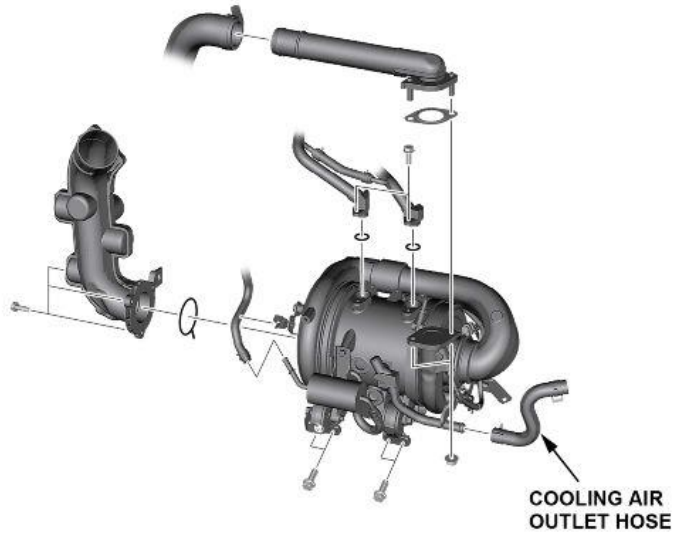

37. Remove the rear mount mounting bolts from the FC stack.

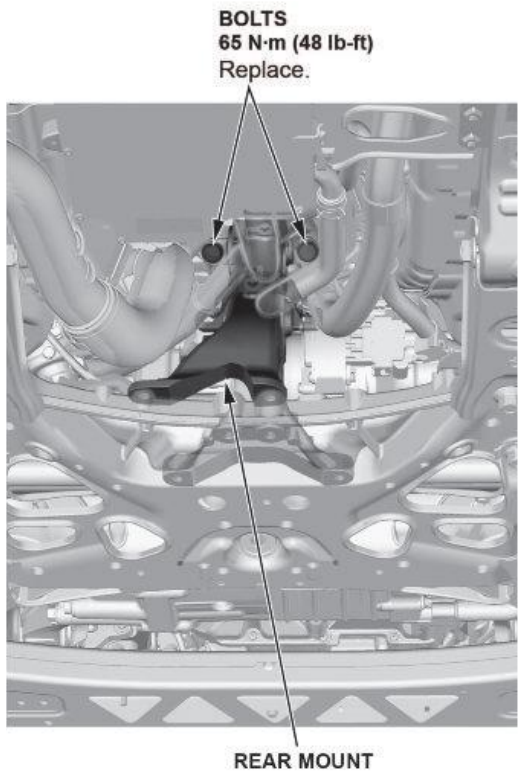

38. Install a chain hoist to the FC stack.

NOTE: Use a commercially available carabiner, eyelet, washer, spacer, and bolt.

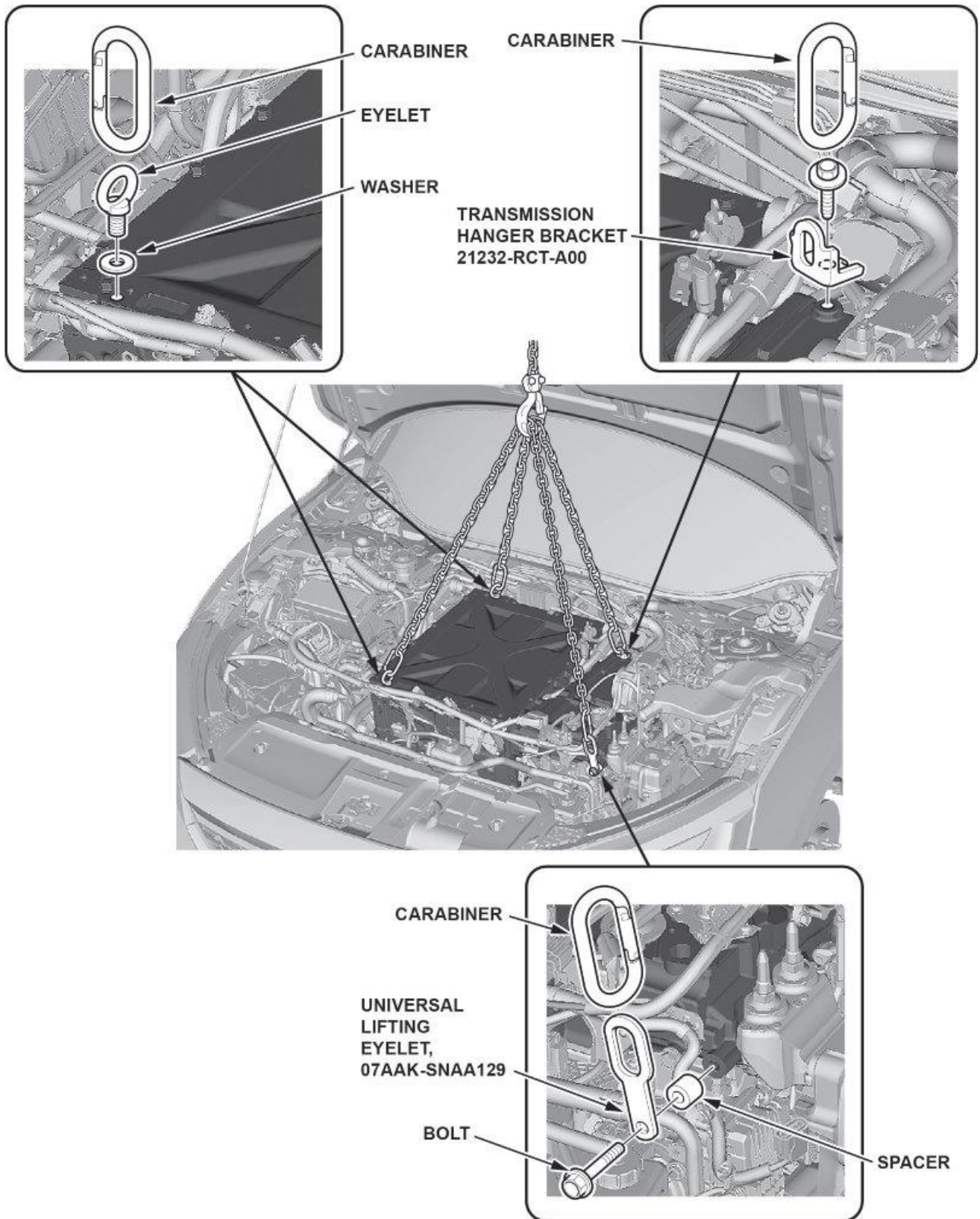

39. Remove the left front and right front stack mounts.

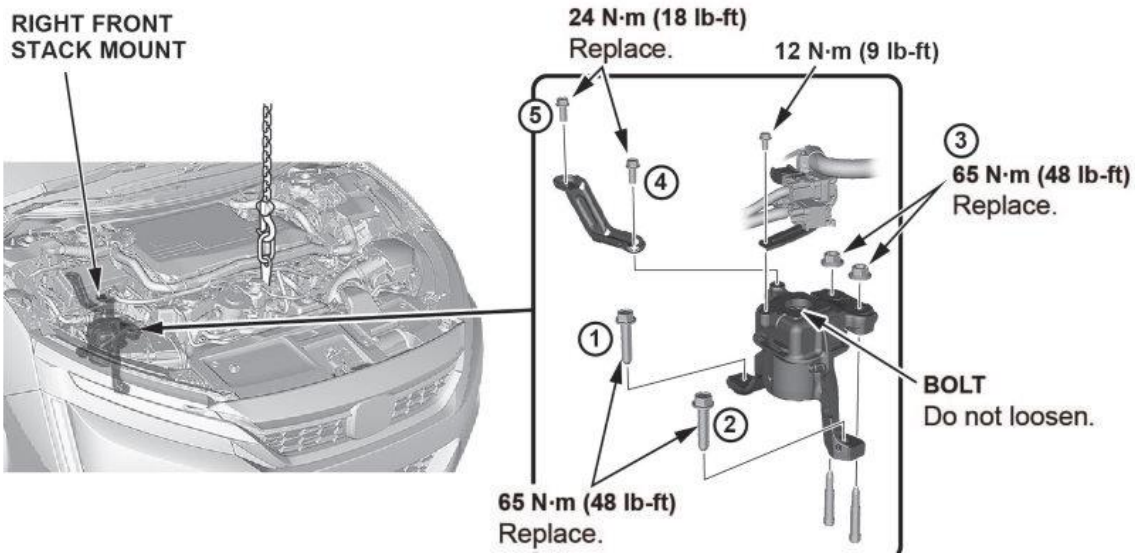
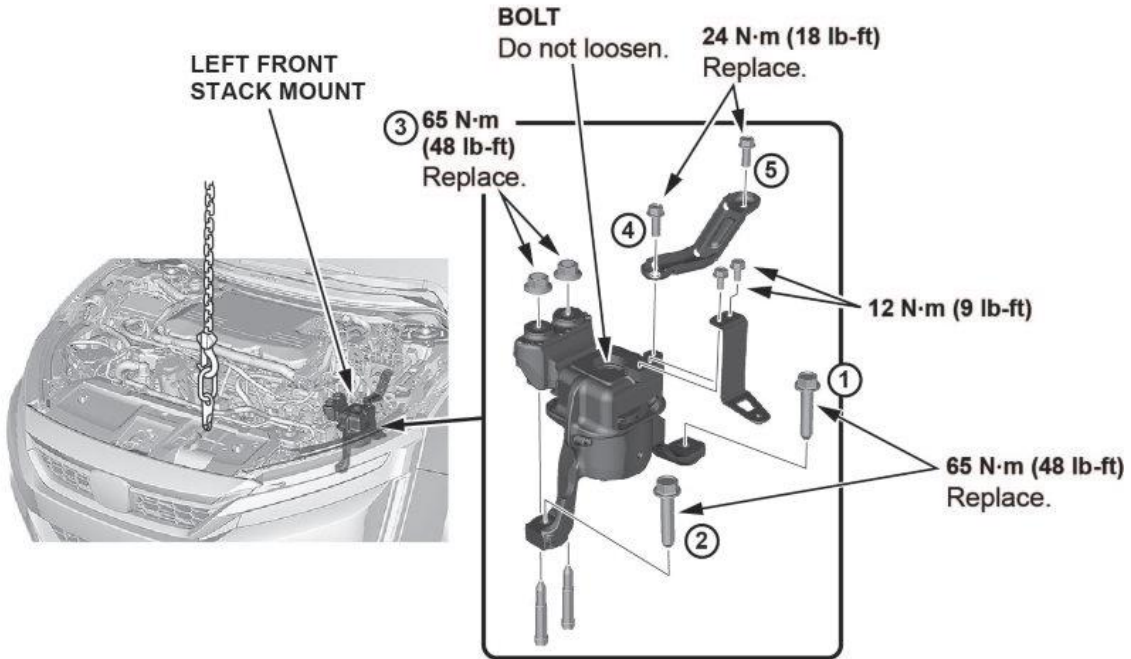

40. Remove the FC stack.

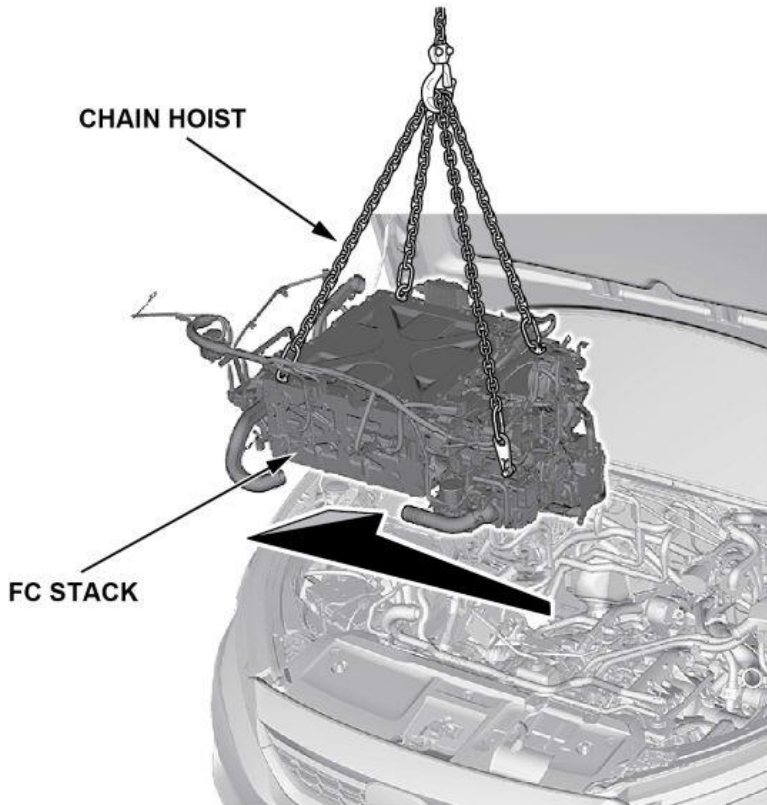

41. Write down the VIN and serial number (SN) of the FC stack on your Repair Order (RO).

Important: If this information is missing on the warranty claim, the claim may be debited. Make sure you write it down on the RO.



42. Take the FC stack to the vehicle that is receiving the stack.
43. Install the FC stack in reverse order using the parts as needed from the stack kit.
44. Install a new FC ion exchanger filter.

NOTE: Remove the cover using an oil filter wrench.

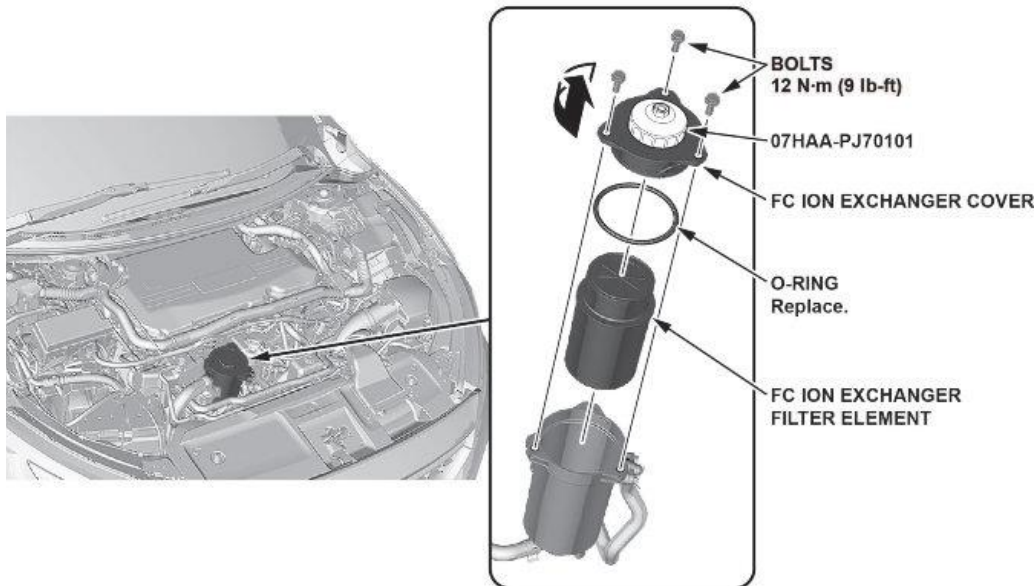

45. Install all of the removed parts in the reverse order of removal.
46. Reset the maintenance minder (A1) using the i-HDS.

NOTE:

- If you are unable to successfully reset the maintenance minder, turn the ignition to OFF and wait 10 minutes after the air pump unit has stopped.
- After turning the ignition to OFF, the air pump unit will continue to operate for a minute or less (it may be longer in low temperatures) and shutoff automatically. Once the air pump unit stops, wait at least 10 minutes to start the maintenance minder reset procedure.
- To check if the air pump unit is running, go to the back of the vehicle and check the diluter (exhaust pipe outlet). You should hear and feel air coming out of it. Once you stop hearing and feeling the air, the air pump unit has stopped.

47. Update Software.

SOFTWARE INFORMATION

NOTE: Unnecessary or incorrect repairs resulting from a failure to update the diagnostic and reprogramming software are not covered under warranty.

Before beginning the repair, make sure all diagnostic and reprogramming software are updated as listed.

i-HDS Software Version	1.006.042 or later
HDS Software Version	3.104.047 or later
J2534 Rewrite Software Information	
PC Application Version	1.2.1.1
Database Update	08-OCT-2021 or later
NoticeDB Version	08-OCT-2021 or later

Before beginning the repair, make sure that both the i-HDS and J2534 software are updated as listed above.

Update only the systems and software listed in this service bulletin.

American Honda has validated and approved the Denso DST-I as the vehicle communication interface (VCI) to support this service bulletin.

For more information about updating vehicle systems, refer to service bulletin 01-023, *Updating Control Units/Modules*.

Year/Model	Vehicle System	Program ID (or later)	Program P/N (or later)
2019 Clarity	Fuel Cell	FC Powertrain System	3K201-5WM-A330
2020-21 Clarity	Fuel Cell	FC Powertrain System	3K201-5WM-A530

REPAIR PROCEDURE

NOTE:

- Connect a fully charged jumper battery to the vehicle, and leave it connected during the entire procedure to maintain steady voltage.
 - Control module failure caused by the improper completion of a software update (early key cycle, low battery voltage, disconnected DLC cable, etc.) is not covered by warranty.
 - To prevent control unit damage, do not operate anything electrical (headlights, audio system, brakes, A/C, power windows, door locks, etc.) during the update.
1. Update the FC Powertrain System software using the J2534 Rewrite software with the MVCI or DST-i. Refer to service bulletin 01-023, *Updating Control Units/Modules*.

END