



# Technical Service Bulletin

---

**35 Gearbox Malfunction warning on, DTC P17F900 with symptom code 22345 is stored in the TCM**

35 21 39 2064312/1 October 20, 2021.

Model(s)	Year	VIN Range	Vehicle-Specific Equipment
A4, A4 allroad, A5, A5 Cabriolet, A5 sportback, A6, A6 allroad, A6 Avant, A7, Q5, and Q5 sportback	2021 - 2022	All	DL382

## Condition

### Customer states:

- The gearbox malfunction message is on.

### Workshop findings:

The following DTC may be stored in the transmission control module (TCM), J217 (address word 0002):

- **DTC P17F900** (Parking lock Mechanical malfunction) with symptom code 22345.

There may be various other DTCs indicating a low hydraulic pressure.

## Technical Background

Not applicable.

## Production Solution

Not applicable.

## Service



**Tip:** Please read the entire work procedure before starting the actual work so the scope and number of the repair options are understood completely.



# Technical Service Bulletin

---

If the DTC P17F900 with symptom code: **22345** is stored *Active/Static* (Figure 1) continue with this repair. If the DTC is not active/static and/or the symptom code does not match, this TSB does not apply.

**DTC memory entry**

Number: **P17F900: Parking lock Mechanical malfunction**  
Error type 2: **active/static**  
Symptom: **22345**  
Status: **10100111**

**Figure 1.** DTC code, active/static, and symptom code.

1. Follow Guided Fault Finding for the DTC and if the result of the test plan states to replace the Parking Lock Solenoid N486 then proceed with this repair.  
*If Guided Fault Finding recommends a different repair this TSB **does not** apply.*
2. If the result of the Guided Fault Finding test plan was to replace Parking Lock Solenoid N486 the next step is to remove the Mechatronics unit per the Elsa Repair Manual.
3. After removing the Mechatronics unit perform a visual inspection of the installation of the bolts for pressure filter 2 (Figure 2, Position 10 and 11) this is the smaller of the 2 canister filters installed to the mechatronics unit with 3 bolts attaching the filter to the unit (Figure 3).

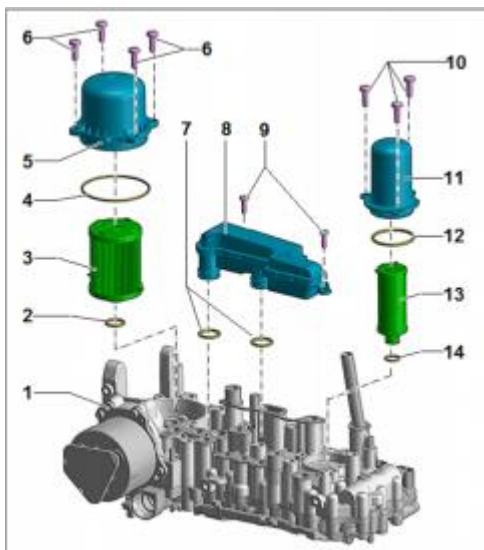

**Figure 2.** Mechatronics Parts



**Figure 3.** Bolt locations.

4. After inspecting the bolts there are 3 different repairs that can be performed depending on your findings:



# Technical Service Bulletin

---

## Option 1

One or more bolts are loose (Figure 4).

You may also see the securing ring is not flush to the valve body which would mean the bolts are loose.

If the bolts are loose, replace pressure filter 2 along with the bolts as described in the Workshop Manual. Claim Option 1 in the Warranty Table below.

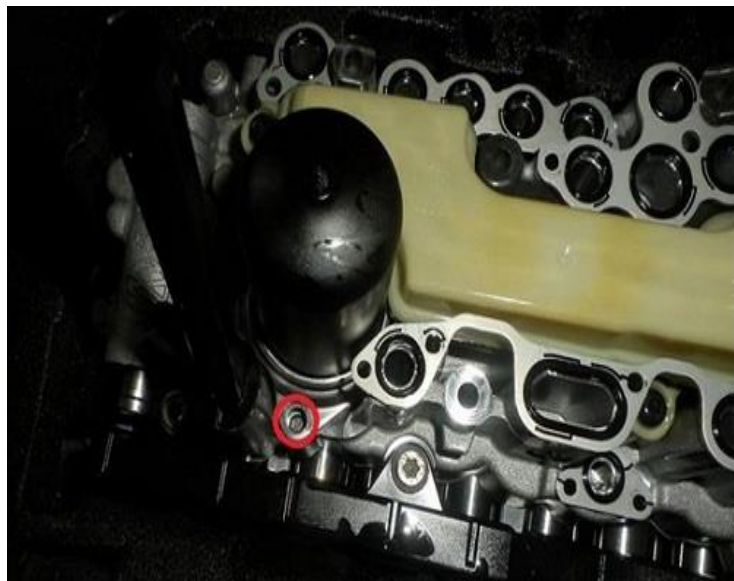

*Figure 4. Loose bolts.*

## Option 2:

One or more Bolt heads are broken off or missing (Figure 5).

If any of the bolts are broken, replace the Valve Body and reuse the Transmission Control Module per the Elsa Repair Manual. (If no valve body is available for your vehicle replace the Mechatronics unit and note this on the repair order). Claim Option 2 in the Warranty Table below.



*Figure 5. Bolt head is missing.*



# Technical Service Bulletin

## Option 3:

All 3 bolts are tight. Replace the Parking Lock Solenoid N486 and the Pressure pipe for the N486 (Figure 4) per the Elsa Repair Manual. Claim Option 3 in the Warranty Table below.

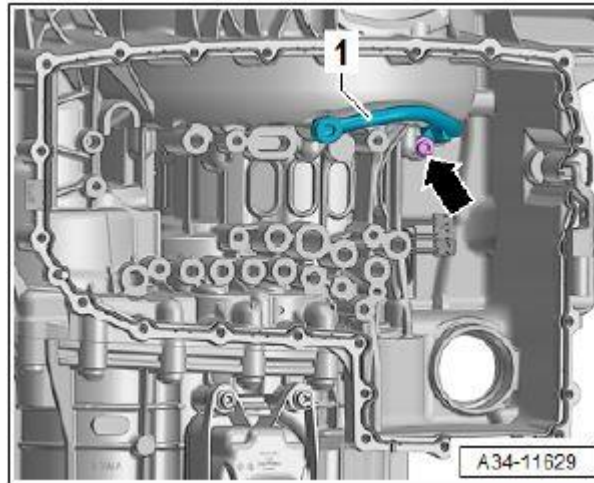

**Figure 4.** Pressure pipe for the parking lock solenoid.

5. After the repair perform a test drive to confirm proper operation.

## Warranty

<b>Claim Type:</b>	<ul style="list-style-type: none"> <li>• 110 up to 48 Months/50,000 Miles.</li> <li>• G10 for CPO Covered Vehicles – Verify Owner.</li> <li>• If the vehicle is outside any warranty, this Technical Service Bulletin is informational only.</li> </ul>		
<b>Service Number:</b>	3511		
<b>Damage Code:</b>	0010		
<b>Labor Operations: (All three options)</b>	Remove and install mechatronic unit	3511 19XX	See SRT with associated operations
	Check mechatronic unit	3511 0199	10 TU
<b>Repair Option #1</b>	Replace oil filter (pressure filter)	3488 5599	20 TU
<b>Repair Option #2</b>	Mechatronic disassemble and reassemble (replace valve body)	3511 3750	See SRT with associated operations
<b>Repair Option #3</b>	Replace hydraulic control unit	3482 5599	40 TU



# Technical Service Bulletin

<b>Diagnostic Time:</b>	GFF	0150 0000	Time stated on the diagnostic protocol (Max 60 TU)
	Road test prior to service procedure	No allowance	0 TU
	Road test after service procedure	0121 0004	10 TU
<b>Claim Comment:</b>	As per TSB #2064312/1		

All warranty claims submitted for payment must be in accordance with the *Audi Warranty Policies and Procedures Manual*. Claims are subject to review or audit by Audi Warranty.

## Required Parts and Tools

Always check with your Parts Department and/or ETKA for the latest information and parts bulletins.		
<b>All Repair options require the following parts:</b>		
Part Number	Part Description	Quantity
See ETKA	Fasteners, Bolts, Nuts and Screws as needed per the Elsa Repair Manual	See ETKA/ELSA
N 10156207	Oval Hexagon socket head bolts (Pan Bolts)	25
0CK325107F	Tube	01
0CK321439A	Threaded plug	02
0CK301191A	Gasket	01
N 10739402	Bolt, hex head with shoulder	07
0CK325444	Gasket	01
0CK325445	Gasket	01
0CK325443	Gasket	01
0CK325446	Gasket	01
0CK927523	Gasket	01
0CK321371A	Gasket	01



# Technical Service Bulletin

---

<b>Repair Option #1 Additional Parts:</b>		
<b>Part Number</b>	<b>Part Description</b>	<b>Quantity</b>
0CK325149D	Pressure Filter	01
0CK325371D	Cover with seal	01
N 10787901	Round Head Screw	04
0CK325421A	Suction Filter	01
N 10787701	Round Head Screw	02

<b>Repair Option #2 Additional Parts:</b>		
<b>Part Number</b>	<b>Part Description</b>	<b>Quantity</b>
Order to VIN	Valve Body	01
N 10701101	Hexagon socket flat	03
N 91127901	Hexalobular flange screw	04

<b>Repair Option #3 Additional Parts:</b>		
<b>Part Number</b>	<b>Part Description</b>	<b>Quantity</b>
0CK325497H	Hydraulic control unit (N486)	01
0CK301131B	Gasket	01
N 10710402	Oval hexagon socket head bolt	04
N 91126101	Hexagon socket flat head bolt	01
0CK325319A	Tube	01
N 91173601	Hexalobular flange screw	01

## Additional Information

---



# Technical Service Bulletin

---

All parts and service references provided in this TSB (2064312) are subject to change and/or removal.

©2021 Audi of America, Inc. All rights reserved. Information contained in this document is based on the latest information available at the time of printing and is subject to the copyright and other intellectual property rights of Audi of America, Inc., its affiliated companies and its licensors. All rights are reserved to make changes at any time without notice. No part of this document may be reproduced, stored in a retrieval system, or transmitted in any form or by any means, electronic, mechanical, photocopying, recording, or otherwise, nor may these materials be modified or reposted to other sites without the prior expressed written permission of the publisher.