

Bicycle Rack

Revision: This bulletin replaces bulletin Group 6 38/14, dated August 1, 2019.

Model Year: **As of 2003**

- Vehicle Types:
- **Taycan Cross Turismo (Y1B) – all vehicles with roof rails (3S1/3S2)** with roof transport system (EQUIPMENT)
 - **Taycan (Y1A) – all vehicles with panoramic fixed-glass roof (3FG)** with roof transport system (EQUIPMENT)
 - **Macan (95B) – all models** with roof rails (3S1/3S5) or with roof transport system (5W1/5W4)
 - **911 Carrera (992)/Turbo (992) – all models, body type: ONLY for Coupé** with roof transport system (EQUIPMENT)
 - **911 Carrera (991)/Turbo (991) – all models, body type: Coupé ONLY** with roof transport system (549)
 - **911 Carrera (997)/Turbo (997) – all models, body type: Coupé ONLY** with roof transport system (549)
 - **Panamera (971) – all models NOT Executive** with roof transport system (549 or EQUIPMENT)
 - **Panamera (970) – all models NOT Executive** with roof transport system (549)
 - **Cayenne (9YB) – all Coupé models** with roof transport system (EQUIPMENT)
 - **Cayenne (9YA) – all models** with roof rails (3S1/3S2) and roof transport system (5W1/5W4)
 - **Cayenne (92A) – all models** with roof rails (3S1/3S5) or with roof transport system (5W1/5W4)
 - **Cayenne (9PA) – all models** with roof rails (3S7) or with roof transport system (3S8)

Information: **Instructions for assembly and use**



Figure 1

Restriction: **NOT** suitable for bicycles with carbon frame!

Note: Up to three bicycle racks (⇒ *Figure 1*) can be installed on the base carriers (roof rail bars or roof transport system, referred to below simply as "roof transport system") of the vehicles specified above.

The bicycle rack:

- was tested on the vehicles specified above and adapted accordingly;
- is approved for the transport of bicycles (mountain bikes or racing bikes) weighing up to max. 20 kg/ 44 lbs
- can hold bicycles with a tube diameter in the frame holder (claw) area of 22 to 80 mm/ 0.87 in to 3.15 in (circular cross-section) and up to max. 22 to 100 mm / 0.87 in to 3.94 in (oval cross-section - upright).

Parts Info: **95B.044.800.06** ⇒ Bicycle rack, set

Parts List:



Figure 2

- 1 x Bicycle rack (assembly ⇒ *Figure 2-1-*) including:
- 2 x Wheel mount (front/rear) with turnbuckle ⇒ *Figure 2-2-*
- 1 x Support tube (pivoting) with frame holder (claw) ⇒ *Figure 2-3-*

— — — —	1 x	Retainer plate (rear) ⇒ <i>Figure 2-4-</i>
— — — —	1 x	Quick-release clamp ⇒ <i>Figure 2-5-</i>
— — — —	1 x	Retainer plate (front) ⇒ <i>Figure 2-6-</i>
— — — —	1 x	Tensioning lever with lock ⇒ <i>Figure 2-7-</i>
955.044.000.59	2 x	⇒ Spare key, set (2 keys with key code) ⇒ <i>Figure 2-8-</i>
— — — —	2 x	Tensioning lever ⇒ <i>Figure 2-9-</i>
— — — —	2 x	Rim protector ⇒ <i>Figure 2-10-</i>
— — — —	2 x	Tension strap ⇒ <i>Figure 2-11-</i>
— — — —	2 x	T-bolt, M6 x 61 ⇒ <i>Figure 2-12-</i>
— — — —	1 x	T-bolt, M6 x 35 ⇒ <i>Figure 2-13-</i>
— — — —	3 x	Barrel nut, M6 ⇒ <i>Figure 2-14-</i>
— — — —	1 x	"Bicycle frame mounting" notice ⇒ <i>Figure 2-15-</i>
— — — —	1 x	Instructions for assembly and use (not shown)

Spare Parts:	95B.044.800.36	1 x	⇒ Assembly kit (small parts/spare parts), set comprising:
— — — —		1 x	Tensioning lever for lock/lock cylinder ⇒ <i>Figure 2-7-</i>
— — — —		2 x	Tensioning lever ⇒ <i>Figure 2-9-</i>
— — — —		2 x	Rim protector ⇒ <i>Figure 2-10-</i>
— — — —		2 x	Tension strap ⇒ <i>Figure 2-11-</i>
— — — —		2 x	T-bolt, M6 x 61 ⇒ <i>Figure 2-12-</i>
— — — —		1 x	T-bolt, M6 x 35 ⇒ <i>Figure 2-13-</i>
— — — —		3 x	Barrel nut, M6 ⇒ <i>Figure 2-14-</i>

Note: The keys (⇒ *Figure 2-8-*) can be re-ordered if lost by specifying the part number and the code "Nxxx" (possible codes range from N001 to N200) shown on the lock cylinder.

- Technical Data:
- Length: 1,440 mm/ 56.7 in
 - Max. width: 350 mm/ 13.8 in
 - Max. height: 100 – 690 mm/ 3.94 in — 27.16 in
 - Empty weight: 3.7 kg/ 8.16 lbs¹

¹ Observe permissible roof load for the roof transport system (⇒ Owner's Manual, section on 'Weights')!



Improper loading and installing of the roof transport system or add-on modules

- Danger of objects falling down
- Danger of objects sticking out

- ⇒ Load the roof transport system or add-on modules in such a way that the load does not project over the sides of the roof area.
- ⇒ Select the distances between several add-on modules mounted next to each other so that the transported items cannot bump against each other during the trip.
- ⇒ Secure load sufficiently to prevent it from shifting during the trip.
- ⇒ Check the roof transport system or add-on modules regularly before each trip and during an extended trips to make sure they are seated correctly and securely on the vehicle.

⚠ CAUTION**Driving with a roof load**

- Higher center of gravity
 - Larger area exposed to the wind
 - Different vehicle handling
- ⇒ Adapt driving style accordingly.
 - ⇒ Read the speed instructions and general information on the "Roof transport system" in the Owner's Manual.

**Information**

Please inform the customer of this accordingly.

Work Procedure: 1 Prepare bicycle rack for assembly

- 1.1 Unpack bicycle rack and check that all items required are included.
- 1.2 Install T-bolts
 - 1.2.1 Unlock lock cylinder on tensioning lever with lock (⇒ *Figure 3-A*) and remove tensioning lever with lock (⇒ *Figure 3-B*).

- 1 – Key
- 2 – Tensioning lever with lock

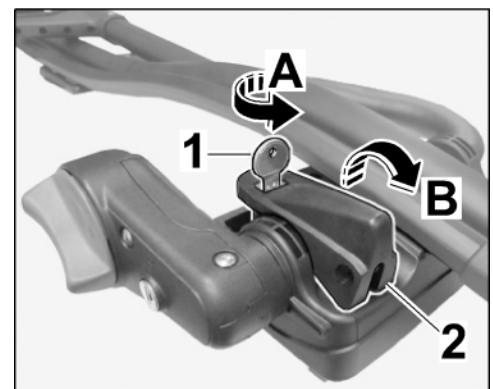

Figure 3

1.2.2 Insert M6 barrel nuts (3 ea.) into the tensioning levers (3 ea.) (⇒ *Figure 4*).

- 1 – Barrel nut, M6 (3 x)
- 2 – Tensioning lever (2 x)
- 3 – Tensioning lever with lock (1 x)

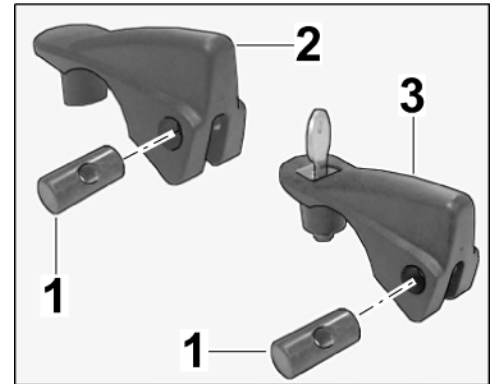

Figure 4



Information

Check the marking at the bore!

1.2.3 Guide T-bolt (M6 x 35) from below through the bore with the marking (⇒ *Figure 5 -inset-*) on the retainer plate (rear) (⇒ *Figure 5 -A-*).

- 1 – T-bolt, M6 x 35
- 2 – Retainer plate (rear)
- 3 – Tensioning lever
- 4 – T-bolt, M6 x 61
- 5 – Retainer plate (front)
- 6 – Tensioning lever with lock
- inset** – Marking

Screw tensioning lever approx. 3 turns onto the T-bolt (M6 x 35) (⇒ *Figure 5 -B-*).

1.2.4 Guide T-bolt (M6 x 61) through the bore on the retainer plate (front ⇒ *Figure 5 -5-*) (⇒ *Figure 5 -A-*).

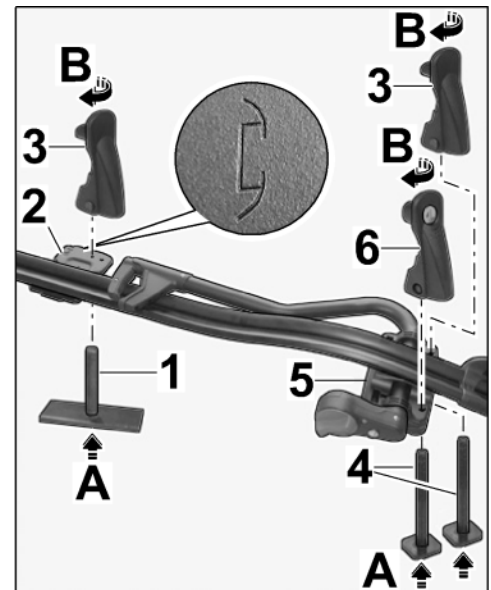

Figure 5

Screw tensioning lever with lock (⇒ *Figure 5 -6-*) approx. 3 turns onto the T-bolt (M6 x 61) (close to quick-release clamp) (⇒ *Figure 5 -B-*).

Screw the second tensioning lever approx. 3 turns onto the T-bolt (M6 x 61) (⇒ *Figure 5*).

1.3 Install tension strap and rim protector

- 1 – Turnbuckle
- 2 – Wheel mount
- 3 – Tab on wheel mount
- 4 – Tension strap
- 5 – Rim protector

- 1.3.1 Press turnbuckle, on the side with the tab, on the wheel mount (⇒ *Figure 6-A-*).

**Information**

The locking teeth on the tension strap must be facing outwards!

- 1.3.2 Push tension strap as far as it will go through the turnbuckle from below (⇒ *Figure 6-B-*).

- 1.3.3 Install rim protector as far as it will go onto the tension strap (⇒ *Figure 6-C-*)

- 1.3.4 Adjust tension strap with rim protector installed and insert it into the tab on the wheel mount.

- 1 – Tension strap
- 2 – Rim protector
- 3 – Tab on wheel mount

- 1.3.5 Install the second tension strap in the same way.

- 2 Install roof transport system on the vehicle (⇒ Owner's Manual, section on 'Roof Transport System').

- 3 **ONLY for Cayenne (9PA; MY 2003 – 2010):** Position roof carrier systems on the vehicle.

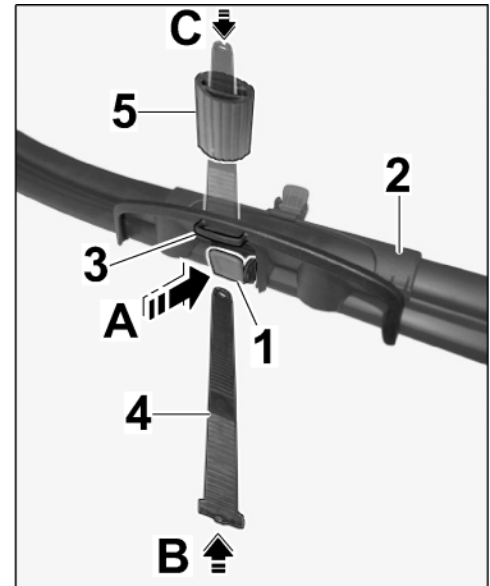

Figure 6

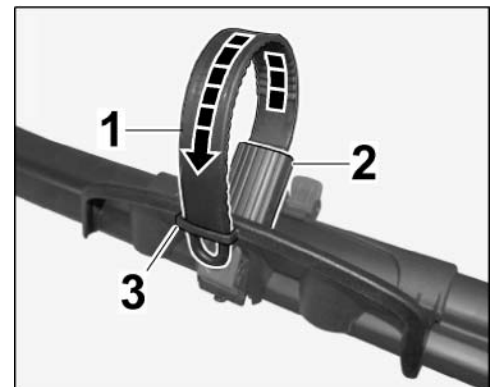

Figure 7

3.1 Vehicles with roof transport system

arrow – Cut-out in guide rail

1-2 – Groove in guide rail for carrier (front)

3-6 – Groove in guide rail for carrier (rear)

X – Control dimension approx. 800 mm/ 31.5 in

3.1.1 Open side roof transport system caps on the roof transport system carrier.

3.1.2 Install the front/rear carrier into the large cut-out on the guide rail (⇒ *Roof transport system on the Cayenne (9PA) -arrow-*) and push it forward or back towards the side grooves in the guide rails (⇒ *Roof transport system on the Cayenne (9PA) -top-*).

You will feel slight resistance and hear a click at these positions.

- Position of front carrier: front groove (⇒ *Roof transport system on the Cayenne (9PA) -1-*)
- Position of rear carrier: second groove after the large cut-out (⇒ *Roof transport system on the Cayenne (9PA) -4-*)

3.1.3 Check gap **X** between the carriers (⇒ *Roof transport system on the Cayenne (9PA) -bottom-*).

Gap X: Control value 800 mm +/- 5 mm

3.1.4 Decide which side (driver's or passenger's side) you want to install the add-on modules (roof box, bicycle rack, etc.) on and close the cap on the carrier on the opposite side.

This secures the carrier and prevents it from moving lengthways.

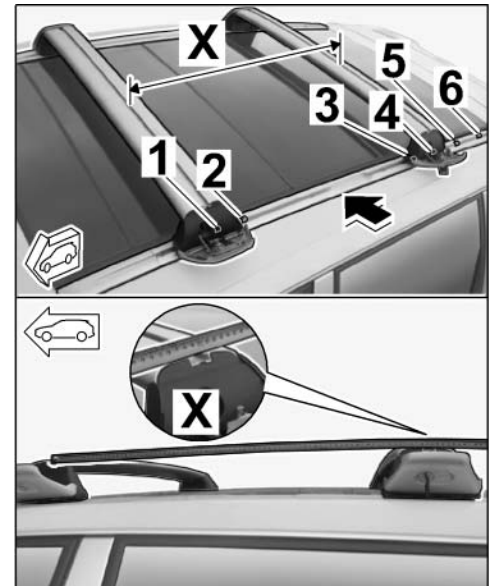

Roof transport system on the Cayenne (9PA)

3.2 Vehicles with roof rails

- 1 – Front bar/seam dimension
- 2 – Rear bar/seam dimension
- X – Control dimension approx. 800 mm/ 31.5 in

3.2.1 Loosen front/rear bar, check gaps with respect to the seam and make adjustments if necessary (⇒ *Roof rail bars on the Cayenne (9PA)*).

- **Front bar: Control value 25 mm +/-2 mm**
- **Rear bar: Control value 150 mm +/-2 mm**

3.2.2 Bolt both bars securely to the roof rails.

3.2.3 Decide which side (driver's or passenger's side) you want to install the add-on modules (roof box, bicycle rack, etc.) on and close the caps on the opposite side.

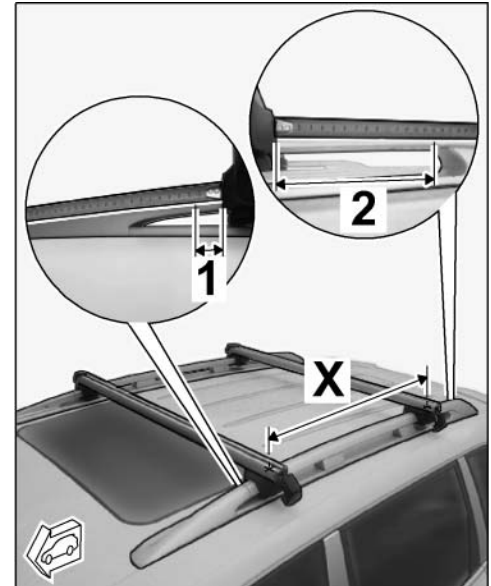

Roof rail bars on the Cayenne (9PA)

WARNING

Improper loading and installing of the roof transport system or add-on modules

- Danger of objects falling down
 - Danger of objects sticking out
- ⇒ Load the roof transport system or add-on modules in such a way that the load does not project over the sides of the roof area.
- ⇒ Select the distances between several add-on modules mounted next to each other so that the transported items cannot bump against each other during the trip.
- ⇒ Secure load sufficiently to prevent it from shifting during the trip.
- ⇒ Check the roof transport system or add-on modules regularly before each trip and during an extended trips to make sure they are seated correctly and securely on the vehicle.

CAUTION

Incorrect installing, use or care of the bicycle rack

- Risk of damage to the roof of the vehicle, rear lid and/or bicycle rack
- ⇒ Position the bicycle in the bicycle rack leaving the same amount of space at front and rear. Make sure that the center of gravity of the load is between both roof racks.

- ⇒ Remove loose parts on the bicycle, e.g. drinking bottles, child seats, saddlebags, etc., before installing the bicycle.
- ⇒ Do NOT cover the bicycle with tarpaulins or protective covers.
- ⇒ Because bicycles can be difficult to handle, always install/remove the bicycle on the bicycle rack with the help of another person.
- ⇒ For high vehicles, use a small ladder or work platform (step) if necessary.
- ⇒ Make sure there is a sufficient gap between the tension straps and the roof of the vehicle.
- ⇒ Remove the bicycle rack from the roof of the vehicle before washing the vehicle in an automatic car wash.
- ⇒ Bear in mind the new overall vehicle height when driving through tunnels or under low branches and when driving into garages and multi-storey parking garages.
- ⇒ Clean the bicycle rack using soapy water only (without alcohol, chlorine or ammonia additives); other substances can attack and damage the surface.
- ⇒ Do not stick stickers on the bicycle rack. The adhesive film can dissolve the surface of the bicycle rack or cause tension cracks.
- ⇒ Spray the locks on the bicycle rack with commercially available spray lubricant from time to time. The lubricant must not come into contact with the plastic surface of the bicycle rack.
- ⇒ When opening the rear lid for the first time, make sure there is sufficient space between the rear lid and the installed bicycle rack/bicycle. Move the bicycle rack/bicycle forward in direction of travel if necessary.

4 Pre-Install the bicycle rack on the roof transport system

- 4.1 Open the cap of the roof transport system (front/rear) on one side (⇒ Owner's Manual, section on 'Roof Transport System') and install the bicycle rack on the roof transport system.

- 4.2 Check the position of the next sliding block (T-bolt, M6 x 61 ⇒ *Figure 8-1-*) with respect to the groove in the roof transport system carrier.

- 1 – T-bolt, M6 x 61
- 2 – Retainer plate (front)
- 3 – Guide pins for retainer plate (front)
- 4 – Groove in roof transport system carrier (front)
- 5 – T-bolt, M6 x 35
- 6 – Retainer plate (rear)
- 7 – Groove in roof transport system carrier (rear)

Push sliding block (T-bolt, M6 x 61) into the groove in the front carrier.

- 4.3 Move T-bolt (M6 x 35 ⇒ *Figure 8-5-*) with rear retainer plate forward/back on the bicycle rack if necessary.
- 4.4 Guide sliding block (T-bolt, M6 x 35) with bicycle rack into the groove in the carrier (⇒ *Figure 8*).
- 4.5 Carefully push the bicycle rack at front and rear to the of the vehicle until the last sliding block (T-bolt, M6 x 61 ⇒ *Figure 8-1-*) is touching the groove in the roof transport system carrier.
Guide sliding block (T-bolt, M6 x 61) with bicycle rack into the groove in the carrier.



Information

When moving the bicycle rack to the left/right on the roof transport system, make sure that the tensioning levers are pointing straight up.

- 4.6 Carefully slide the bicycle rack onto the side of the vehicle on which you want to install the bicycle (the open frame holder (claw) is facing the relevant side of the vehicle (⇒ *Figure 9 -arrow-*)).

- 1 – Bicycle rack
- 2 – Frame holder (claw)
- 3 – Tensioning lever

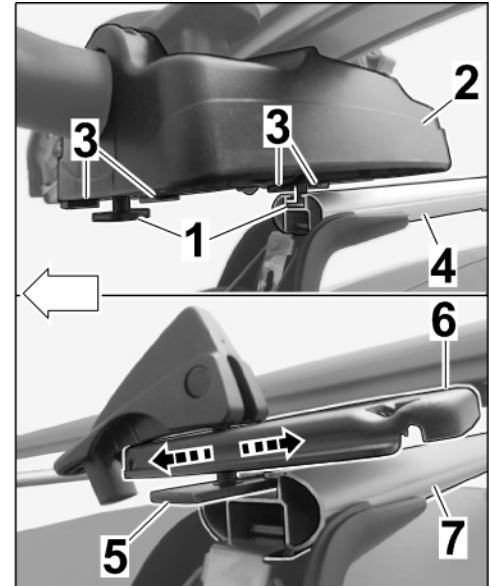

Figure 8

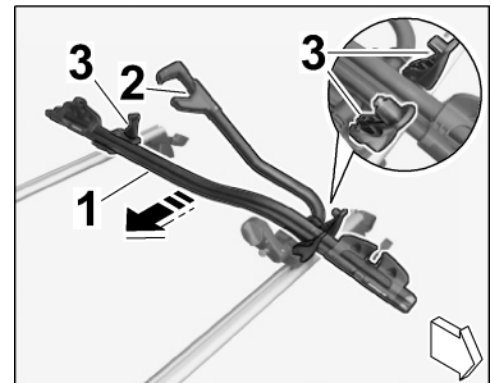

Figure 9

- 4.7 Close the tensioning levers
- 1 – Tensioning lever
 - 2 – Tensioning lever with lock
 - 3 – Guide pins for retainer plate (front)

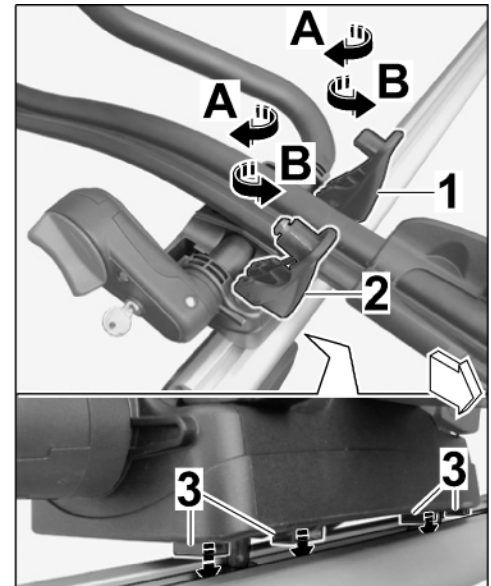

Figure 10

NOTICE

Guide pins for retainer plate (front) not in the groove in the roof transport system carrier

- Bicycle rack loose
 - Damage to bicycle rack and/or roof transport system
- ⇒ **When tightening the tensioning lever on the retainer plate (front), make sure that the guide pins are in the groove in the roof transport system carrier.**
- ⇒ **Check the position of the guide pins after securing them.**

- 4.7.1 Turn the tensioning lever on the retainer plate (front) clockwise by 10 to 12 turns (⇒ *Figure 10-A*).

- 4.7.2 Adjust the tensioning lever towards the retainer plate using the required amount of force (⇒ *Figure 11 -C-*).

- 1 – Tensioning lever
- 2 – Tensioning lever with lock

If the tensioning lever will not close:
Turn the tensioning lever counter-clockwise by one or two turns (⇒ *Figure 10-B-*).

Adjust the tensioning lever towards the retainer plate using the required amount of force (⇒ *Figure 11 -C-*).

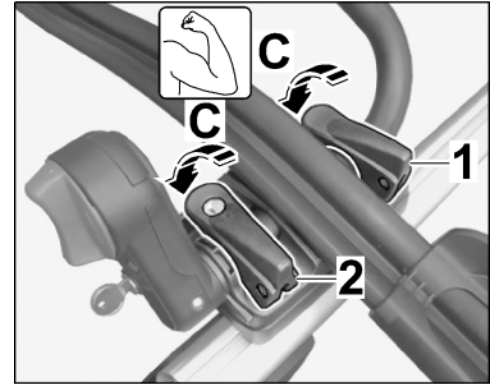

Figure 11

- 4.7.3 Close the tensioning levers on the retainer plate (rear) in the same way
- 4.7.4 Check that the bicycle rack can NO longer move in the roof transport system.

5 Install bicycle on the bicycle rack.

5.1 Preparatory work

- 1 – Lock on rotary knob
- 2 – Button
- 3 – Frame holder (claw)
- 4 – Support tube – pivoting

- 5.1.1 Open the frame holder (claw) in the pivoting support tube (⇒ *Figure 12 -C-*): Open the lock on the rotary knob (⇒ *Figure 12 -A-*) and press the button (⇒ *Figure 12 -B-*).

- 5.1.2 Swivel support tube with frame holder (claw) upwards (⇒ *Figure 12 -D-*).

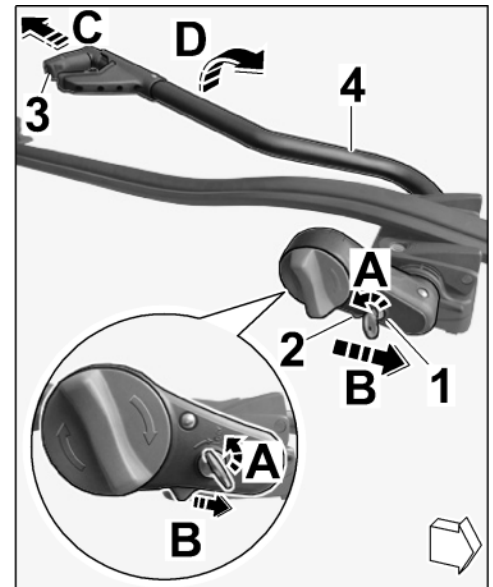

Figure 12



Information

The following frame sizes on the bicycle frame down tube are permitted (⇒ Fig. 13):

- for oval tube cross-section: $x = 22$ to 80 mm/ 0.87 in to 3.15 in; $Y = 22$ to 100 mm/ 0.87 in to 3.94 in
- for circular cross-section: $x = 22$ to 80 mm/ 0.87 in to 3.15 in

5.2 Install bicycle

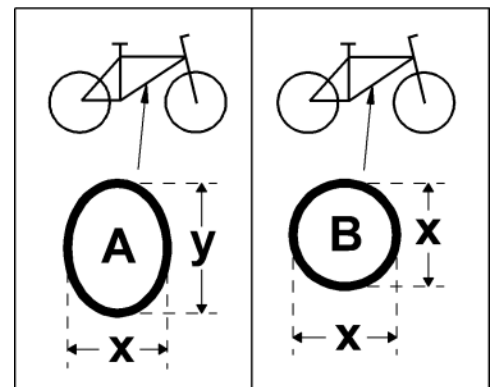

Figure 13

5.2.1 Carefully place the bicycle on the bicycle rack with the help of another person (⇒ Figure 14 -A-) and hold it securely.

- 1 – Carrier profile for bicycle rack
- 2 – Support tube (pivoting) with frame holder (claw)
- 3 – Rotary knob on quick-release clamp



Information

Pay particular attention to the following points when positioning the frame holder (claw)/bicycle frame down tube:

- The frame holder (claw) must enclose the bicycle frame down tube at the center
- The frame holder (claw) must be close to the chain wheel so that the (pivoting) support tube and bicycle frame down tube (depending on design) form an angle of approx. 90°
- Be careful of any cables/lines on the bicycle frame down tube!

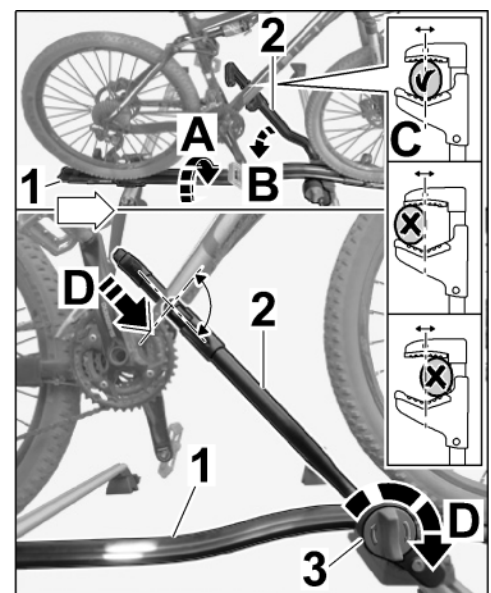

Figure 14

- 5.2.2 Position frame holder (claw) on the down tube of the bicycle frame at the center (⇒ *Figure 14 -C-*) and close to the chain wheel (⇒ *Figure 14 -B-*).
- 5.2.3 Turn rotary knob to the right until the frame holder (claw) secures the down tube (⇒ *Figure 14 -D-*).
- 5.2.4 Align wheel mount (front/rear) vertically under the wheel hubs of the front/rear wheel (⇒ *Figure 15*).
- 1 – Front wheel mount
 - 2 – Rear wheel mount
 - 3 – Tension strap for wheel mount (front/rear)
 - 4 – Rotary knob
- 5.2.5 Turn rotary knob (⇒ *Figure 15 -4-*) as far as possible to the right.

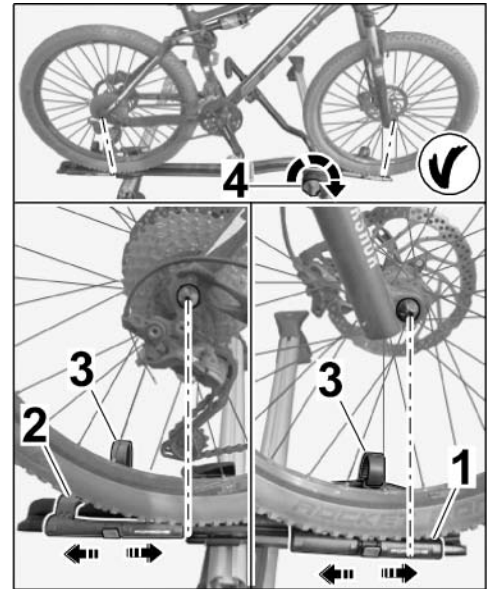

Figure 15

- 5.2.6 Guide tension strap between the spokes over the wheel rim. Center the rim protector over the wheel rim (⇒ *Figure 16 -top-*).

- 1 – Tension strap
- 2 – Turnbuckle
- 3 – Rim protector
- 4 – Lock on rotary knob

- 5.2.7 Insert tension strap into the turnbuckle. Tighten tension strap on both sides in such a way (⇒ *Figure 16 -arrows-*) that the tension strap secures the wheel symmetrically (⇒ *Figure 16 -bottom-*).

Check the distance from the ends of the tension strap to the roof of the vehicle.

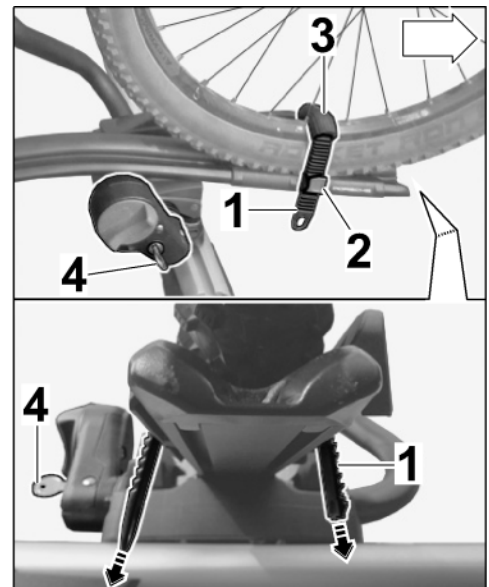

Figure 16

- 5.2.8 Check that the bicycle is installed securely in the bicycle rack by shaking it.

- 5.2.9 Close the lock on the rotary knob (⇒ *Figure 16 -4-*). The frame holder (claw) can no longer be opened.
- 5.3 Align bicycle with bicycle rack with respect to the roof transport system and vehicle.

5.3.1 Sideways, with respect to the longitudinal axis of the vehicle (⇒ *Figure 17*):

- Bicycle with bicycle rack, installed by itself: Symmetrical with respect to the center of the vehicle/roof transport system
- Bicycle with bicycle rack and other carrier systems (e.g. a second bicycle rack or roof box): Carrier systems, as well as the load, must not hit against each other during the trip.
- Bicycle with bicycle rack and other carrier systems must NOT project over the surface area of the vehicle.

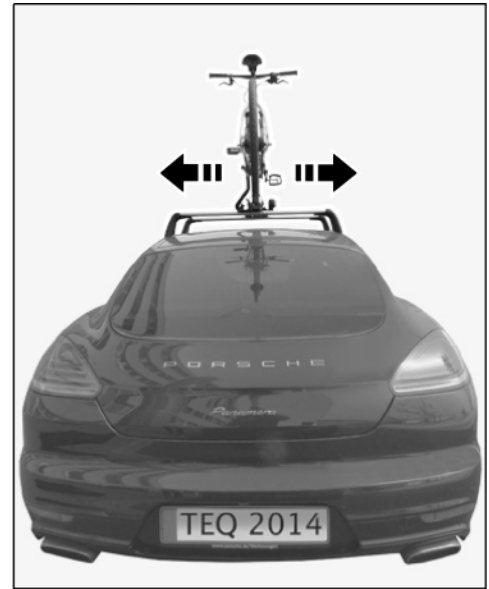

Figure 17

5.3.2 Overhang to the rear (rear window/rear lid or tailgate ⇒ *Figure 18*):

- Overhang to the rear: Gap "X" must be maintained when the rear lid or tailgate is open fully.

5.3.3 Carefully open the rear lid/tailgate of the vehicle and adjust gap "X" with respect to the bicycle/bicycle rack.

ONLY for vehicles with (automatic) rear lid/powerlift tailgate: Set the opening angle (opening height) of the rear lid (⇒ Owner's Manual, 'Adjusting the opening height of the tailgate' in section on 'Tailgate').

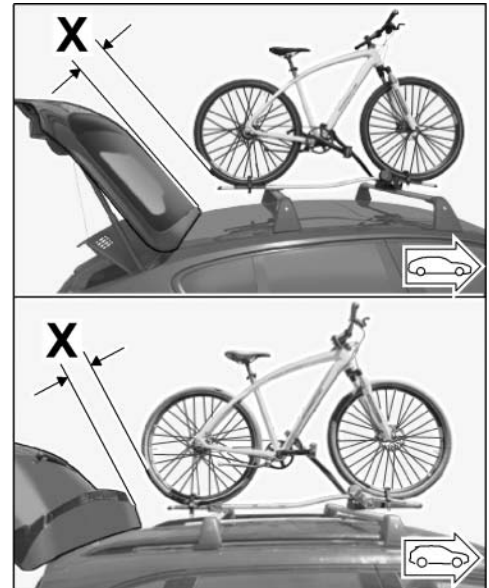

Figure 18

5.3.4 Close the caps on the roof transport system.

6 Remove bicycle

- 6.1 Open the tensioning levers (3 ea.) on the bicycle rack. Carefully slide the bicycle rack to the side of the vehicle on which you want to remove the bicycle (the open frame holder (claw) is facing the relevant side of the vehicle).

Close the tensioning levers (3 ea.) on the bicycle rack again.

- 6.2 Unlock the lock on the rotary knob (⇒ *Figure 19-A-*).

- 1 – Lock on rotary knob
- 2 – Tension strap for wheel mount (front/rear)
- 3 – Button

- 6.3 Loosen tension strap for wheel mount (front/rear) and guide it through the front/rear wheel (⇒ *Figure 19-B-*).

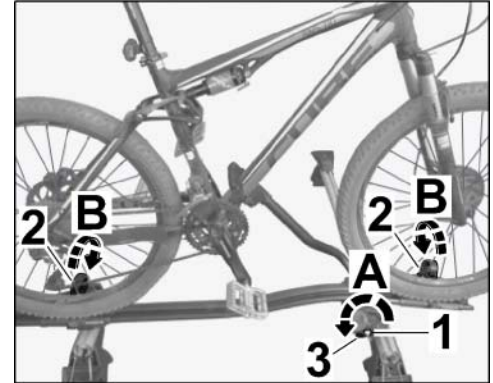

Figure 19

- 6.4 Hold the bicycle securely and press the button (⇒ *Figure 20-C-*).

- 1 – Button
- 2 – Frame holder

The frame holder opens (⇒ *Figure 20-D-*).

- 6.5 Carefully remove the bicycle with the help of another person.

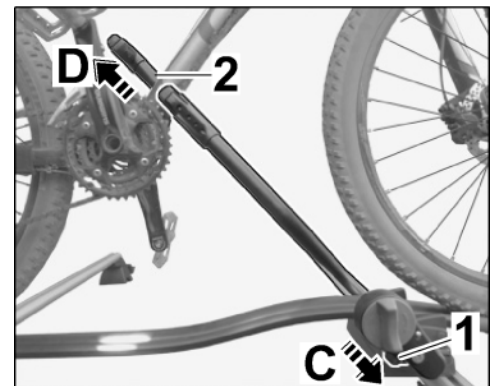

Figure 20

6.6 Swivel the frame holder (claw) and support tube onto the rear wheel mount (⇒ *Figure 21 -A-*) and secure it to the wheel mount with the tension strap.

- 1 – Support tube (pivoting)
- 2 – Frame holder (claw)
- 3 – Tension strap
- 4 – Wheel mount (front)
- 5 – Lock on rotary knob
- 6 – Lock on tensioning lever

6.7 Guide (front) tension strap into the lock for the wheel mount (⇒ *Figure 21 -5-*), align it symmetrically and then tighten it.

6.8 Align bicycle rack symmetrically on the roof transport system carrier bars. Adjust the tensioning lever and close the lock on the tensioning lever (⇒ *Figure 21 -7-*).

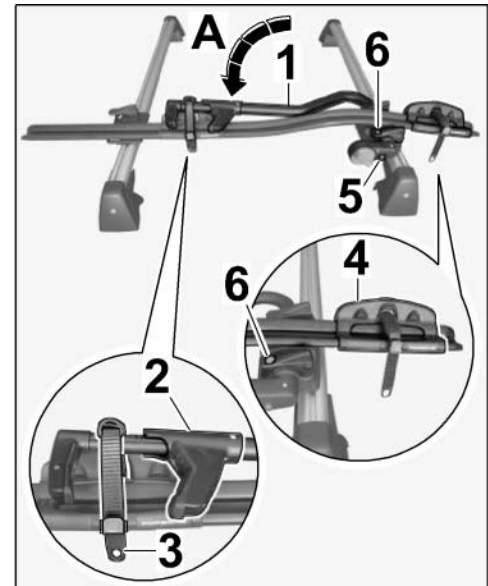

Figure 21

7 Remove bicycle rack.

7.1 The bicycle rack is removed in reverse order.

7.2 Close the caps on the roof transport system.

7.3 Store the bicycle rack and accessories.

66 92 31 00: –Bicycle rack (1 x) installed–
 Includes: Unpacking bicycle rack, reading instructions for use and installing one bicycle rack.
 Without: Installing roof transport system, installing and removing bicycle.

Labor time: **40 TU**

66 92 31 50: –Bicycle rack (2 x) installed–
 Includes: Unpacking another bicycle rack and installing it on the open roof transport system.
 Without: Installing roof transport system, installing and removing bicycle.

Labor time: **10 TU**

Important Notice: Technical Bulletins issued by Porsche Cars North America, Inc. are intended only for use by professional automotive technicians who have attended Porsche service training courses. They are written to inform those technicians of conditions that may occur on some Porsche vehicles, or to provide information that could assist in the proper servicing of a vehicle. Porsche special tools may be necessary in order to perform certain operations identified in these bulletins. Use of tools and procedures other than those Porsche recommends in these bulletins may be detrimental to the safe operation of your vehicle, and may endanger the people working on it. Properly trained Porsche technicians have the equipment, tools, safety instructions, and know-how to do the job properly and safely. Part numbers listed in these bulletins are for reference only. The work procedures updated electronically in the Porsche PIWIS diagnostic and testing device take precedence and, in the event of a discrepancy, the work procedures in the PIWIS Tester are the ones that must be followed.

© 2021 Porsche Cars North America, Inc.