



David J. Johnson  
Director  
Service Engineering Operations  
Ford Customer Service Division

Ford Motor Company  
P. O. Box 1904  
Dearborn, Michigan 48121

September 30, 2021

**TO:** All U.S. Ford and Lincoln Dealers

**SUBJECT:** **Customer Satisfaction Program 21B49**  
Certain 2021 Model Year Bronco Vehicles Equipped with a Hard Top Roof  
Roof Panel Delamination

**REF:** **Awareness Communication - Upcoming Customer Satisfaction Program 21B49**  
Dated August 12, 2021

### **PROGRAM TERMS**

This program will be in effect through September 30, 2022. There is no mileage limit for this program.

### **AFFECTED VEHICLES**

<b>Vehicle</b>	<b>Model Year</b>	<b>Assembly Plant</b>	<b>Build Dates</b>
Bronco	2021	Michigan	January 28, 2021 through August 11, 2021

Affected vehicles are identified in OASIS and FSA VIN Lists.

### **REASON FOR THIS PROGRAM**

In all of the affected vehicles, the exposed or unsealed edges on the molded in color hard top roof may cause an unsatisfactory appearance when exposed to extreme water and humidity. This concern is strictly an appearance issue as the function of the roof is uncompromised.

### **UNIQUE REQUIREMENTS**

Prior to scheduling customer appointments, submit a VIN-specific Part Order type contact via the Special Service Support Center (SSSC) web contact site. Once the hard top roof kit and both quarter glass parts arrive at the dealer, install both new quarter glass to the new hard top rear cap assembly to reduce customer wait time at the dealer. Proceed with customer appointment **only after** both fixed quarter glass are installed on the new hard top rear cap assembly.

**IMPORTANT:** To ensure that the earliest Bronco owners receive the first opportunity to have their hard top roof replaced, part orders will only be accepted for vehicles included on the VIN list in Attachment V. As additional hard top roof kits become available, the VIN list attachment will be updated without an entire bulletin supplement so please review it on a weekly basis.

### **SERVICE ACTION**

Dealers will replace all hard top roof panels and the hard top rear cap assembly and install new fixed quarter glass in the new rear cap assembly on all the affected vehicles. This service must be performed on all affected vehicles at no charge to the vehicle owner.

**Note:** The new fixed quarter glass can be installed by the dealer technicians or by a sublet glass company. Dealership service management is to provide a copy of the Fixed Quarter Glass Installation procedure (Attachment IV) to the sublet glass company as needed.

**Note:** The liftgate window glass and if equipped, the roof rack and/or any other accessories will be transferred to the new roof assembly.

**Note:** All original factory installed hard top roof parts are required to perform the complete repair.

## **OWNER NOTIFICATION MAILING SCHEDULE**

Awareness letters were mailed to customers late August letting them know that their vehicle is included in the program. Parts to support this repair are currently not available in sufficient quantities to service all of the affected vehicles. Therefore, to ensure an ample supply of parts are available, owners of affected vehicles will receive a second letter letting them know that parts are now available to service their vehicle. Mailing is anticipated to begin the week of October 4, 2021 and will be prioritized by vehicle sale date, from earliest to latest. Dealers should only repair affected vehicles that arrive at their dealerships if the VIN is included in Attachment V even if the customer did not receive a letter.

## **ATTACHMENTS**

Attachment I: Administrative Information  
Attachment II: Labor Allowances and Parts Ordering Information  
Attachment III: Technical Information - Dealership  
Attachment IV: Technical Information - Glass Company  
Attachment V: VIN list - Vehicles Currently Authorized For Part Ordering  
Owner Notification Letter

## **QUESTIONS & ASSISTANCE**

For questions and assistance, contact the Special Service Support Center (SSSC) via the SSSC Web Contact Site. The SSSC Web Contact Site can be accessed through the Professional Technician System (PTS) website using the SSSC link listed at the bottom of the OASIS VIN report screen or listed under the SSSC tab.

Sincerely,



David J. Johnson

**Customer Satisfaction Program 21B49**  
Certain 2021 Model Year Bronco Vehicles Equipped with a Hard Top Roof  
Roof Panel Delamination

**OASIS ACTIVATION**

OASIS will be activated on September 30, 2021.

**FSA VIN LISTS ACTIVATION**

FSA VIN Lists will be available through <https://web.fsavinlists.dealerconnection.com> on September 30, 2021. Owner names and addresses will be available by October 25, 2021.

**NOTE:** Your FSA VIN Lists may contain owner names and addresses obtained from motor vehicle registration records. The use of such motor vehicle registration data for any purpose other than in connection with this program is a violation of law in several states, provinces, and countries. Accordingly, you must limit the use of this listing to the follow-up necessary to complete this service action.

**SOLD VEHICLES**

- Owners of affected vehicles will be directed to dealers for repairs.
- Immediately contact any of your affected customers whose vehicles are not on your VIN list, but are identified on Attachment V. Give the customer a copy of the Owner Notification Letter and schedule a service date.
- Dealers are to prioritize repairs of customer vehicles over repairs of new and used vehicle inventory.

**STOCK VEHICLES**

- Once all current vehicle owners have received their notification that they can request a replacement hard top roof, VIN list based restrictions will be removed to allow part orders for in stock units.
- Use OASIS to identify any affected vehicles, in your used vehicle inventory, that are included in Attachment V.

**TITLE BRANDED / SALVAGED VEHICLES**

Affected title branded and salvaged vehicles are eligible for this service action.

**OWNER REFUNDS**

Refunds are not approved for this program.

**RENTAL VEHICLES**

With proper dealer parts ordering and service appointment scheduling, rental vehicles should not be required. However, if you have a unique owner circumstance which may require a rental vehicle, please contact the SSSC via the SSSC Web Contact Site.

**Customer Satisfaction Program 21B49**  
Certain 2021 Model Year Bronco Vehicles Equipped with a Hard Top Roof  
Roof Panel Delamination

**ADDITIONAL REPAIR (LABOR TIME AND/OR PARTS)**

Additional repairs identified as necessary to complete the FSA should be managed as follows:

- For related damage and access time requirements, refer to the Warranty and Policy Manual / Section 6 – Ford & Lincoln Program Policies / General Information & Special Circumstances for FSA's / Related Damage.
- For vehicles within new vehicle bumper-to-bumper warranty coverage, no SSSC approval is required, although related damage must be on a separate repair line with the "Related Damage" radio button checked.
  - Ford vehicles – 3 years or 36,000 miles
- For vehicles outside new vehicle bumper-to-bumper warranty coverage, submit an Approval Request to the SSSC Web Contact Site prior to completing the repair.

**CLAIMS PREPARATION AND SUBMISSION**

- **Claim Entry:** Enter claims using Dealer Management System (DMS) or One Warranty Solution (OWS) online.
  - When entering claims:
    - Claim type 31: Field Service Action. The FSA number (21B49) is the sub code.
    - Customer Concern Code (CCC): B66 – Other exterior trim troubles
    - Condition Code (CC): D4 – Flaw in material
    - Causal Part Number: 78205G44 – Hard top rear cap
    - Part Quantity: 0
  - For additional claims preparation and submission information, refer to the Recall and Customer Satisfaction Program (CSP) Repairs in the OWS User Guide.
- **Related Damage/Additional labor and/or parts:** Must be claimed as Related Damage on a separate repair line from the FSA with same claim type and sub code as described in Claim Entry above.

**IMPORTANT:** Click the Related Damage Indicator radio button.
- **Rentals:** For rental vehicle claiming, follow Extended Service Plan (ESP) guidelines for dollar amounts. Enter the total amount of the rental expense under Miscellaneous Expense code RENTAL.

**Claims Preparation And Submission Continued On The Next Page**



**Customer Satisfaction Program 21B49**  
Certain 2021 Model Year Bronco Vehicles Equipped with a Hard Top Roof  
Roof Panel Delamination

**CLAIMS PREPARATION AND SUBMISSION (continued)**

- **Provision for Locally Obtained Supplies (cannot be claimed with Sublet Glass Installation Provision):** This expense cannot be claimed if a sublet glass company installs the fixed quarter glass. Includes 50mm (2 in) wide masking tape, lint-free cloth, disposable gloves, Motorcraft® Ultra-Clear Spray Glass Cleaner (ZC-23), urethane adhesive primer applicators/daubers, either Sika® SikaTack® (MACH 60/MACH 30) **or** Dow® BETASEAL™ Express and either Sika® Primer-207 **or** Dow® BETAPRIME™ 5504G. Submit on the same line as the repair.

**NOTE:** The listed chemicals and locally obtained supplies can be used on multiple vehicles.

- Program Code: 21B49
  - Misc. Expense: OTHER
  - Misc. Expense: Claim up to \$80.00
- **Provision for Sublet Glass Installation (cannot be claimed with Locally Obtained Supplies Provision):** This expense cannot be claimed if the dealership install both fixed quarter glass. Sublet repairs to install the fixed quarter glass can be claimed instead of 21B49D. Sublet documentation must be retained. Submit on the same line as the repair.
- Program Code: 21B49
  - Misc. Expense: FSAOSL
  - Misc. Expense: Claim up to \$150.00

**Customer Satisfaction Program 21B49**  
 Certain 2021 Model Year Bronco Vehicles Equipped with a Hard Top Roof  
 Roof Panel Delamination

**LABOR ALLOWANCES**

Description	Labor Operation	Labor Time
<b>3 Door Model</b> - Remove and replace the hard top roof panels and hard top rear cap assembly (Includes time to un-pack the <i>new</i> hard top parts from the crate, swap the liftgate window glass and repackage** the old hard top roof panels and rear cap assembly) <b>This labor operation cannot be claimed with 21B49C</b>	21B49B	1.0 Hours
<b>5 Door Model</b> - Remove and replace the hard top roof panels and hard top rear cap assembly (Includes time to un-pack the <i>new</i> hard top parts from the crate, swap the liftgate window glass and repackage** the old hard top roof panels and rear cap assembly) <b>This labor operation cannot be claimed with 21B49B</b>	21B49C	1.1 Hours
<b>All Vehicles</b> - Install <i>new</i> quarter glass into the <i>new</i> hard top rear cap assembly <b>Cannot be claimed with Sublet Glass Installation Provision</b> <b>This labor operation must be claimed in combination with 21B49B or 21B49C</b>	21B49D	0.6 Hours
<b>All Vehicles</b> - Extra time to swap the roof rack from the old hard top roof onto the <i>new</i> hard top roof (if equipped) <b>This labor operation can be claimed in combination with 21B49B or 21B49C</b>	21B49E	0.3 Hours
<b>All Vehicles</b> - Extra time to transfer aftermarket accessories from the old hard top roof to the <i>new</i> hard top roof (if equipped) <b>- Exclude roof rack</b>	MT21B49F	Actual time up to 1.0 Hours*

\* Dealers are authorized to claim up to 1.0 hours actual time without contacting the SSSC Web Contact Site for approval. Follow the Actual Time Usage Guidelines and Service Management Responsibilities as identified in the Warranty and Policy Manual. Claims for additional parts and/or labor over 1.0 hours should be submitted to the SSSC as a Related Damage contact. If contacting SSSC, please provide the complete tech details and time stamps to support the request for the additional time.

\*\*700 tags will not be issued for dealers in Alaska and Hawaii. Any parts replaced in in those states should be rendered physically unusable and scrapped.

**Customer Satisfaction Program 21B49**  
 Certain 2021 Model Year Bronco Vehicles Equipped with a Hard Top Roof  
 Roof Panel Delamination

**PARTS REQUIREMENTS / ORDERING INFORMATION****SSSC Web Contact Site:**

To place an order for the hard top roof kit and for both the Left Hand (LH) and Right Hand (RH) quarter glass, submit a VIN-specific Part Order contact via the SSSC Web Contact Site.

**3 Door Model**

Part Number	Description	Order Quantity	Claim Quantity
M2DZ-9850196-AA	Hard Top Roof Kit - <b>Less</b> Interior Noise Insulation Headliner	As Required	
M2DZ-9850196-AB	Hard Top Roof Kit - <b>With</b> Interior Noise Insulation Headliner		
M2DZ-9829711-A	LH Quarter Glass - <b>With</b> Tinted/Privacy	As Required	
M2DZ-9829711-B	LH Quarter Glass - <b>Less</b> Tinted/Privacy		
M2DZ-9829710-A	RH Quarter Glass - <b>With</b> Tinted/Privacy		
M2DZ-9829710-B	RH Quarter Glass - <b>Less</b> Tinted/Privacy		

Dealers will be notified via a DOES II communication if circumstances warrant a change in part supply strategy and when open ordering resumes.

**5 Door Model**

Part Number	Description	Order Quantity	Claim Quantity
M2DZ-7850196-AA	Hard Top Roof Kit - <b>Less</b> Interior Noise Insulation Headliner	As Required	
M2DZ-7850196-AB	Hard Top Roof Kit - <b>With</b> Interior Noise Insulation Headliner		
M2DZ-7829701-A	LH Quarter Glass - <b>With</b> Tinted/Privacy	As Required	
M2DZ-7829701-B	LH Quarter Glass - <b>Less</b> Tinted/Privacy		
M2DZ-7829700-A	RH Quarter Glass - <b>With</b> Tinted/Privacy		
M2DZ-7829700-B	RH Quarter Glass - <b>Less</b> Tinted/Privacy		

Dealers will be notified via a DOES II communication if circumstances warrant a change in part supply strategy and when open ordering resumes.

**Parts Requirements / Ordering Information Continued On The Next Page**

**Customer Satisfaction Program 21B49**  
 Certain 2021 Model Year Bronco Vehicles Equipped with a Hard Top Roof  
 Roof Panel Delamination

**PARTS REQUIREMENTS / ORDERING INFORMATION (Continued)**

Order the parts below through normal order processing channels:

**NOTE: Only needed if dealer installs the fixed quarter glass. Cannot be claimed with Sublet Glass Installation Provision.**

Part Number	Description	Order Quantity	Claim Quantity
ZC-23	Motorcraft® Ultra-Clear Spray Glass Cleaner*		
Obtain Locally	50mm (2 in) Wide Masking Tape*		Claim as MISC. OTHER
	Lint-Free Cloth*		
	Disposable Gloves*		
	Urethane Adhesive Primer Applicators/Daubers		
	Sika® Primer-207* <b>or</b> Dow® BETAPRIME™ 5504G*		
	Sika® SikaTack® (MACH 60/MACH 30) <b>or</b> Dow® BETASEAL™ Express		

\* The listed chemicals and locally obtained supplies can be used on multiple vehicles.

To guarantee the shortest delivery time, an emergency order for parts must be placed.

**DEALER PRICE**

For latest prices, refer to DOES II.

**PARTS RETENTION, RETURN, & SCRAPPING**

**NOTE: Retain removed hard top body components and repack into original shipping crate for return. A 700 Tag\*\* is expected to be issued for these parts to be returned.**

Follow the provisions of the Warranty and Policy Manual, Section 1 - WARRANTY PARTS RETENTION AND RETURN POLICIES. If a replaced part receives a scrap disposition, the part must be scrapped in accordance with all applicable local, state and federal environmental protection and hazardous material regulations. Federal law prohibits selling motor vehicle parts or components that are under safety, compliance, or emissions recall.

\*\*700 tags will not be issued for dealers in Alaska and Hawaii. Any parts replaced in in those states should be rendered physically unusable and scrapped.

**EXCESS STOCK RETURN**

Excess stock returned for credit must have been purchased from Ford Customer Service Division in accordance with Policy Procedure Bulletin 4000.

**Customer Satisfaction Program 21B49**  
Certain 2021 Model Year Bronco Vehicles Equipped with a Hard Top Roof  
Roof Panel Delamination

**REPLACED FSA PARTS INSPECTION AND SIGN OFF**

Effective March 1<sup>st</sup> 2021 all parts replaced as part of an FSA repair with a repair order open date of March 1<sup>st</sup> 2021 or later must be inspected and signed off on the repair order by a member of your dealers fixed operations management team or an employee the task has been delegated to. If the task is to be delegated to a non-management employee, the employee needs to be someone other than the technician who completed the repair and needs to understand the importance of completing this task consistently and accurately. All parts replaced as part of an FSA repair should be returned to the parts department following the Warranty Parts Retention and Return Policies.

- Inspect the replaced parts to verify the FSA repair was completed.
- If the FSA repair is found to be complete, the designated employee signs the repair order line or parts return stamp area (electronic or hand signed) for the FSA repair indicating the parts were inspected and validated to have been replaced.
- After the parts have been inspected, they should be handled based on the guidance in the parts status report in the Online Warranty System (Hold, Return, CORE, Scrap, etc.).
- This process is subject to review during warranty audits for FSA repairs with a repair order open date of March 1<sup>st</sup> 2021 or later. Any eligible FSA claims requiring parts replacement, found not to have been inspected and signed off during a warranty audit will be subject to chargeback and consideration for enrollment into the Dealer Incomplete Recall Repair Process.

**Note:** Other approvals (electronic or handwritten) for add-on repair lines, dealer owned vehicle repairs, and repeat repairs do not qualify as FSA parts inspection approvals. The post repair FSA parts inspection process (electronic or handwritten) is independent from other warranty approval requirements. The approval by the designated employee implies that the FSA parts were found to be replaced and must be able to be clearly identified on the Repair Order. If multiple FSA's require approval on a single Repair Order, each applicable occurrence will require individual post repair approval by the designated employee.

## CERTAIN 2021 MODEL YEAR BRONCO VEHICLES EQUIPPED WITH A HARD TOP ROOF — ROOF PANEL DELAMINATION

### UNIQUE REQUIREMENTS

Prior to scheduling customer appointments or beginning repairs, submit a VIN-specific Part Order contact via the Special Service Support Center (SSSC) web contact site. Once the *new* hard top roof kit and both *new* quarter glass parts arrive at the dealer, install both *new* quarter glass to the *new* hard top rear cap assembly to reduce customer wait time at the dealer. Proceed with customer appointment ONLY AFTER both fixed quarter glass are installed on the *new* hard top rear cap assembly.

**NOTE:** The new fixed quarter glass can be installed by the dealer technicians or by a sublet glass company. Dealership service management is to provide a copy of the **FIXED QUARTER GLASS INSTALLATION** procedure (Attachment IV) to the sublet glass company as needed.

### SERVICE PROCEDURE

Is the vehicle present at the dealer?

**YES** - Proceed to **Vehicle Present at the Dealer**. (Page 8)

**NO** - Proceed to **Vehicle Not Present at the Dealer**.

### Vehicle Not Present at the Dealer

**NOTE:** The *new* hard top roof panels, hard top rear cap assembly and liftgate window hinge bolts are shipped in a wooden crate as a part kit. The *new* quarter glass are shipped independently from the wooden crate kit.

**NOTE:** Do not discard any boxes, packing material, foam protective pads or push pin retainers. They will be reused to return the hard top roof panels and the hard top rear cap assembly.

**NOTE:** Excludes dealers in Alaska and Hawaii.



**NOTE:** At all times, the *new* hard top rear cap assembly must remain on the crate foam protective pads, flat and secure, until it is ready to be installed on the vehicle. See Figure 1.

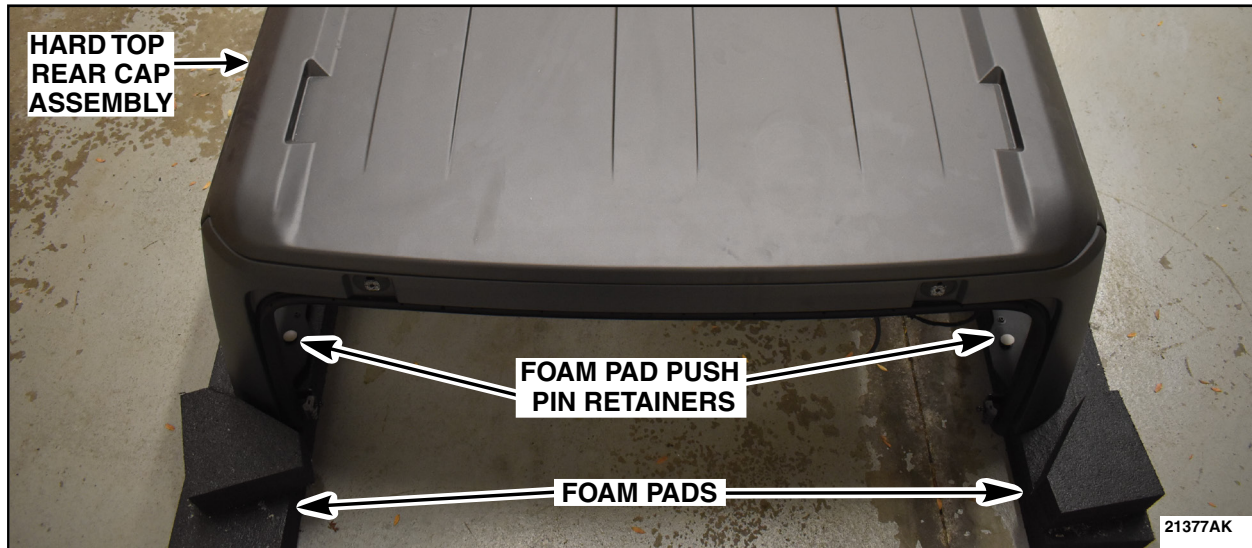
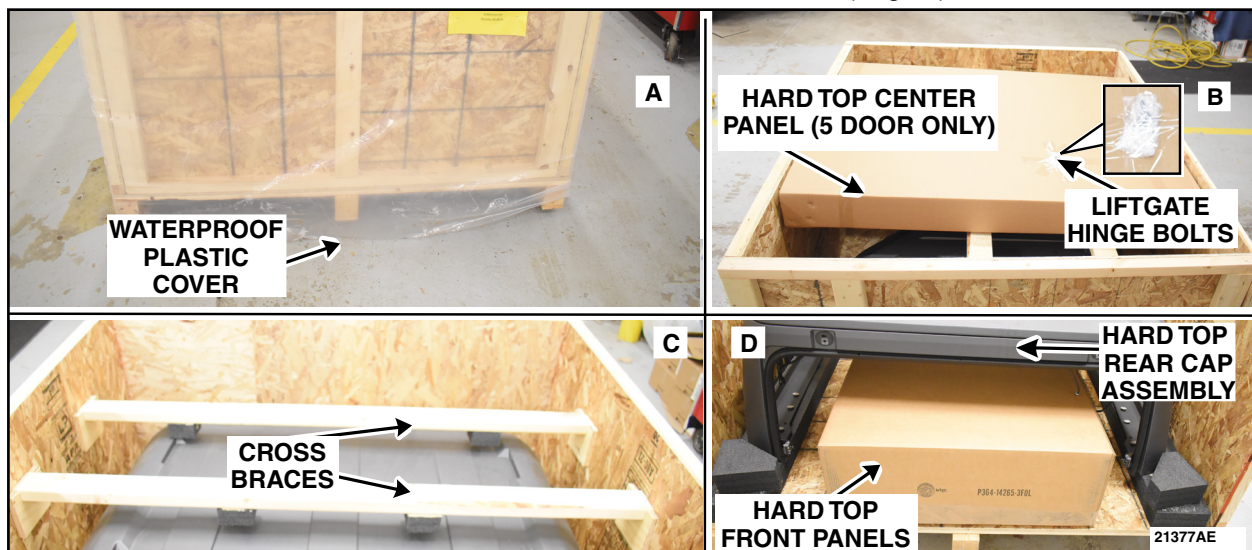

**FIGURE 1**

1. Carefully remove the waterproof plastic cover (A), the top of the crate (B), the cross braces (C), then the end that is screwed in (D). Set aside the cardboard boxes containing the hard top roof panels and the plastic bag containing the liftgate window hinge bolts that will be used later in this procedure. See Figure 2.

**NOTE:** The shipping crate can be used as a level work place for quarter glass installation.

2. Carefully remove the hard top rear cap assembly from the crate. The foam protective pads should remain attached to the *new* hard top rear cap assembly until ready to install on the vehicle. Place the lid back on the crate, and secure it in place by installing the two screws back into the end that was removed. Place the *new* hard top rear cap assembly on the shipping crate for the quarter glass installation. Proceed to **FIXED QUARTER GLASS INSTALLATION**. (Page 3)



**FIGURE 2**





## FIXED QUARTER GLASS INSTALLATION

**NOTICE:** The instructions in this procedure are intended to be followed by dealership technicians or by subletting glass companies. Whether or not a dealership technician or a sublet company install the *new* quarter glass, **DO NOT** leave the masking tape holding the glass in place for prolonged amount of time or exposed to direct sunlight. The masking tape must be removed between two and three hours after the glass installation and prior to returning the vehicle to the customer.

**CAUTION:** The *new* quarter glass should be installed while the *new* hard top rear cap assembly is flat and secure on top of the crate foam protective pads to prevent damage. Ensure the *new* hard top rear cap assembly is sitting on the wooden crate base to prevent damage.

1. Using a clean and dry lint-free cloth, wipe any contamination off the factory primer located on the hard top rear cap assembly quarter glass flanges and on both quarter glass. See Figure 5, on Page 4.

**⚠ IMPORTANT!** The *new* hard top rear cap assembly and both quarter glass are pre-primed. The pre-priming is only good for 90 days from the build date.

2. Inspect the *new* hard top rear cap assembly and the *new* quarter glass labels to make sure the primer has not expired. See Figure 3.

- Is the primer expired (built date is 90 days old or more) or the label is missing?

**YES** - Proceed to Step 3.

**NO** - Proceed to Step 4.



FIGURE 3





**⚠ IMPORTANT:** Primer must be matched to the urethane adhesive (primer must be compatible with urethane being used).

**NOTE:** The use of disposable gloves and safety glasses is required.

**NOTE:** Proper placement of the primer is crucial to avoid appearance concerns. Do not allow the primer to cross into the visible portion of the glass. See Figure 4.

**NOTE:** Fixed quarter glass shown installed on the hard top rear cap assembly for clarity. The view is from the inside of the vehicle looking out. See Figure 4.

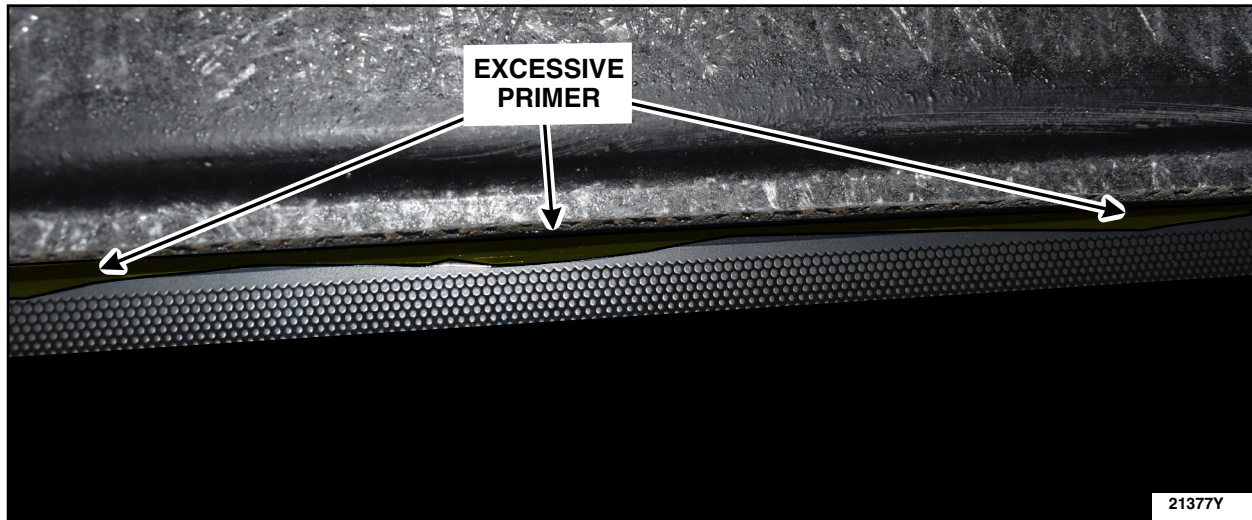

**FIGURE 4**

3. Carefully apply some Sika® Primer-207 or Dow® BETAPRIME™ 5504G primer to the *new* hard top rear cap assembly quarter window glass flanges and to both *new* quarter glass on top of the existing black primer. Minimize applying primer only over the existing black factory primer and allow at least 10 minutes to dry. See Figure 5.

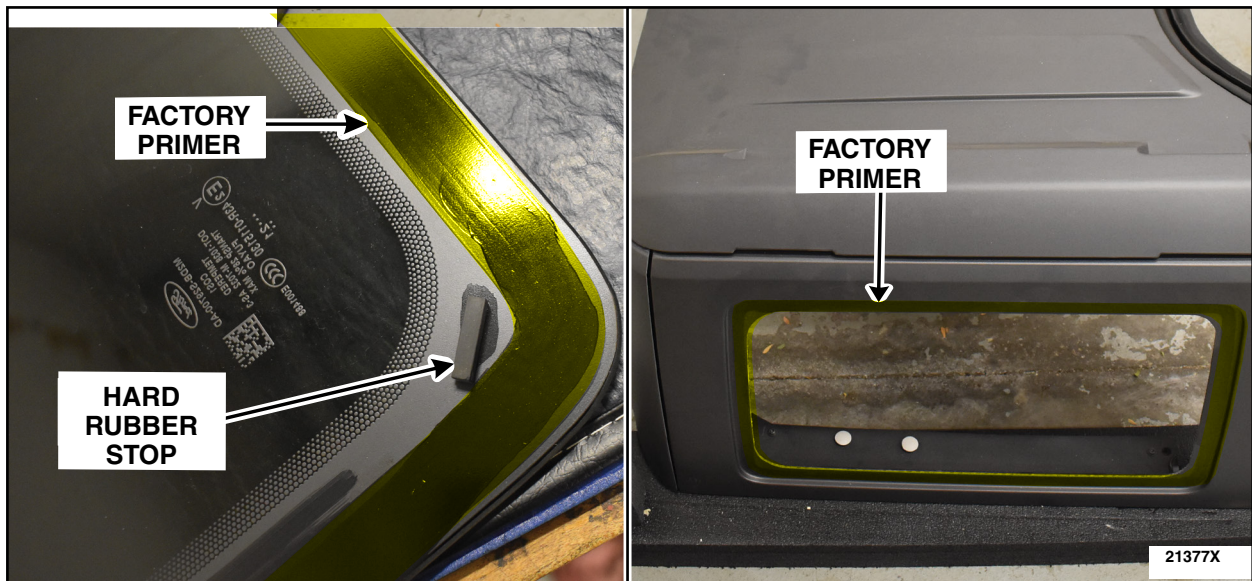
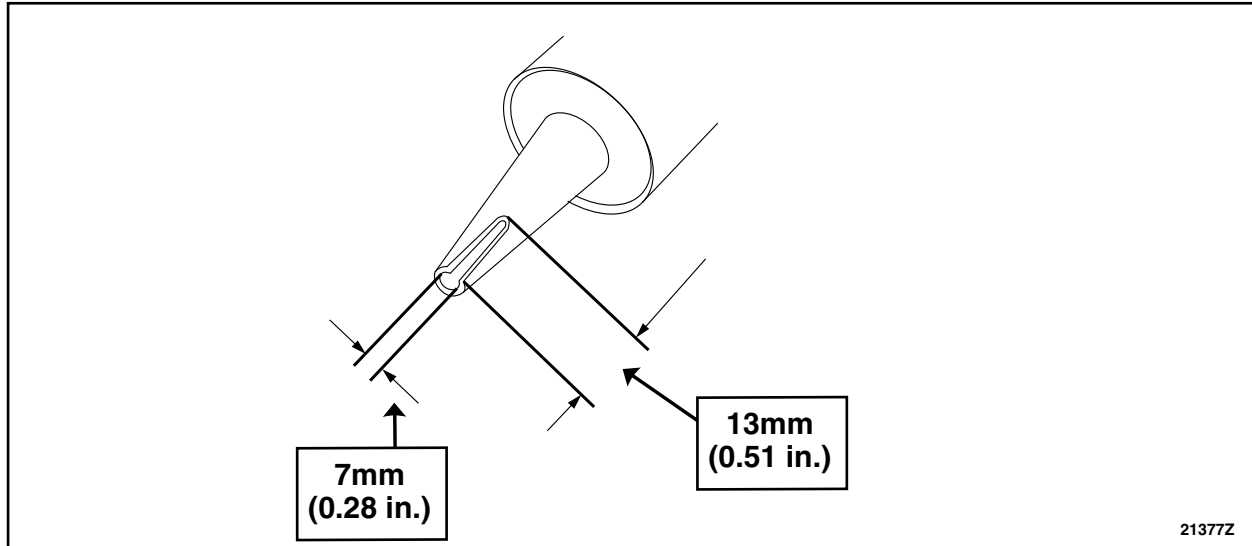

**FIGURE 5**



**NOTE:** For ease of application, it is recommended to warm up the tube of urethane adhesive.

4. Cut the urethane adhesive applicator tip in triangular shape, to specification. See Figure 6.



**FIGURE 6**

**NOTICE:** Make sure there are no gaps in the urethane bead and that the bead is uniform to prevent air and water leaks.

**NOTE:** The *new* quarter glass must be installed within 10 minutes of applying the urethane adhesive.

**NOTE:** Using a power caulk gun helps to apply the urethane adhesive with less effort and with a continuous bead.

**NOTE:** Proper placement and application of the urethane is crucial to avoid appearance concerns.



5. Using a mechanical or power caulk gun, apply some SikaTack® (MACH 60/MACH 30) or Dow® BETASEAL™ Express urethane in a triangular bead 7mm (0.28 in) wide by 13mm (0.51 in) high in the center the primed surface of the *new* hard top rear cap assembly quarter window glass flanges and overlap the bead along front edge of *new* hard top rear cap assembly quarter window glass flanges. The position of the urethane bead should be 14mm (0.55 in) from the outer edge of the *new* hard top rear cap assembly flange to the bead. See Figures 7 and 8.

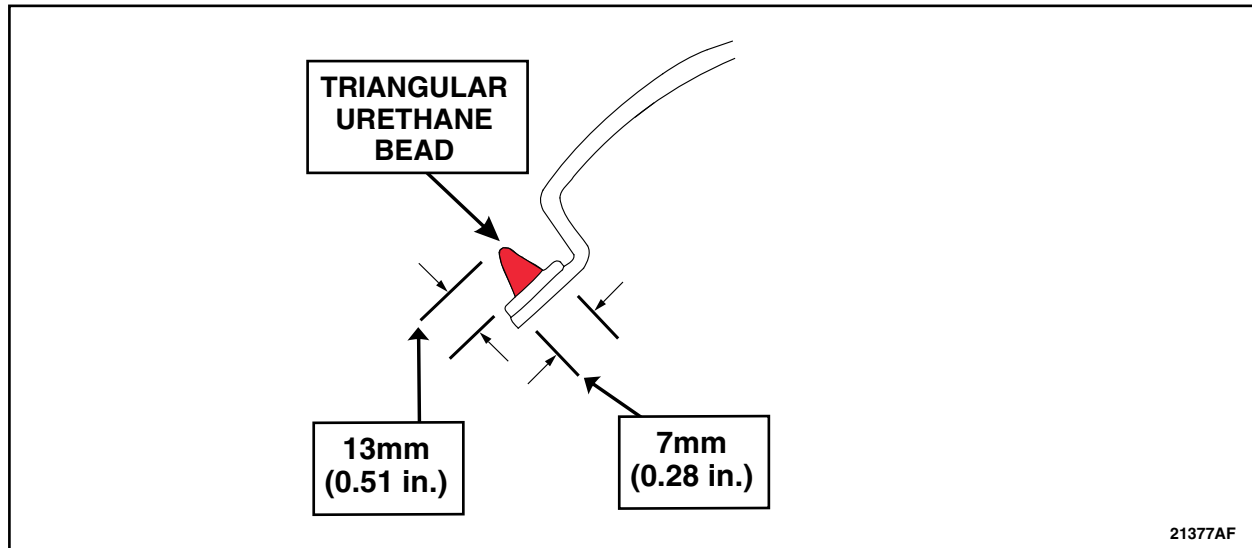

FIGURE 7

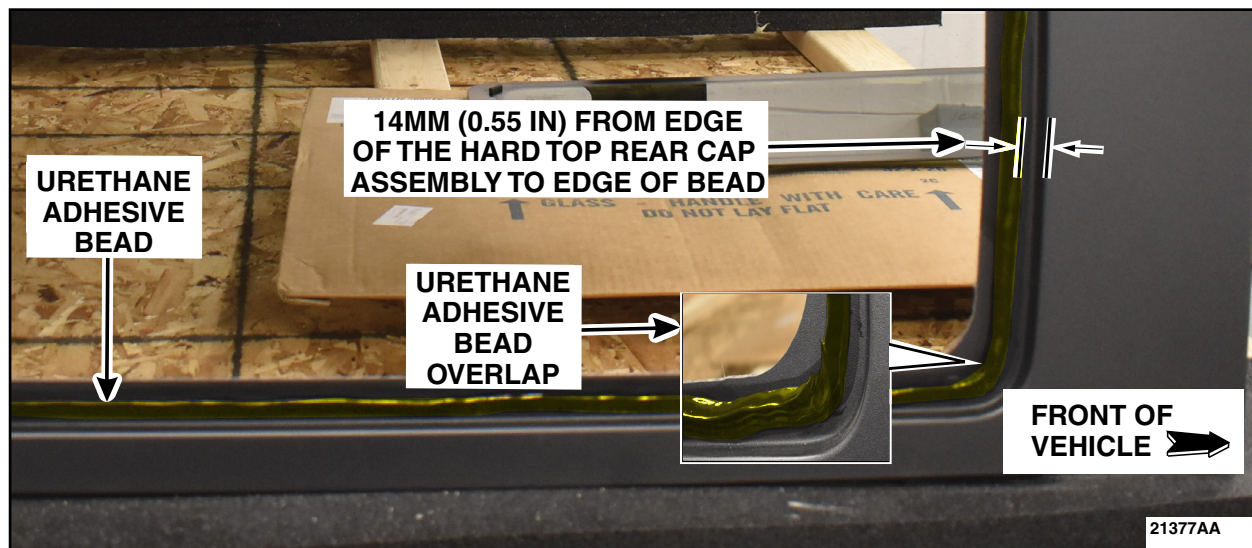

FIGURE 8

**⚠ WARNING:** Improper curing of the urethane adhesive may adversely affect glass retention, which is important for restraint system performance during a crash. Carefully follow the urethane adhesive manufacturer's curing instructions. Do not drive the vehicle until the urethane adhesive seal has cured. Failure to follow these instructions may result in serious injury to vehicle occupant(s) during a crash.

**NOTICE:** Brace by hand the lower portion of the *new* hard top rear cap assembly while pressing the *new* quarter glass into place to prevent damage to the cap assembly.



6. On both sides, install the *new* quarter glass into the *new* hard top rear cap assembly opening, centering the glass in the opening by eye, and pushing it in to the hard rubber stops at the corners to set the depth (flushness). The quarter glass should have about a 3mm (0.12 in) margin to the *new* hard top rear cap assembly all around.

**NOTE:** When installed, the *new* quarter glass will be under flush with the *new* hard top rear cap assembly.

**NOTE:** As needed, wash excess urethane adhesive using Motorcraft® Ultra-Clear Spray Glass Cleaner (ZC-23).

7. Using 50mm (2 in) wide masking tape, secure the *new* quarter glass to the *new* hard top rear cap assembly while the urethane cures. Ensure there is an even 3mm (0.12) gap all the way around the quarter glass. See Figure 9.

**NOTICE:** Whether or not a dealership technician or a sublet glass company install the *new* quarter glass, **DO NOT** leave the masking tape holding the glass in place for a prolonged amount of time or exposed to direct sunlight. **The masking tape must be removed between two and three hours after the glass installation and prior to returning the vehicle to the customer.**

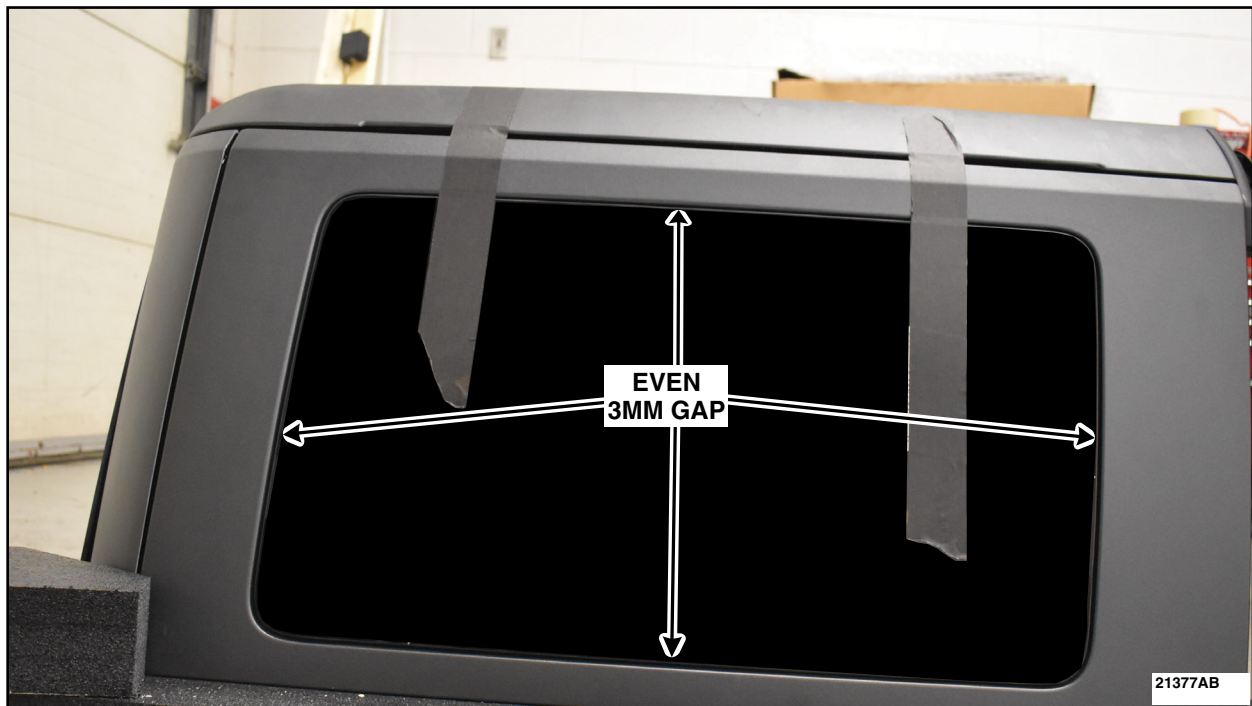

**FIGURE 9**

8. After the masking tape has been removed, ensure there is no tape residue remaining on the surfaces.





## Vehicle Present at the Dealer

**NOTE:** Both fixed quarter glass should have already been previously installed, on the *new* hard top rear cap assembly, prior to the vehicle being present at the dealer. Refer to **Vehicle Not Present at the Dealer**. (Page 1)

1. Is the vehicle equipped with a roof rack and/or other roof mounted accessories?

**Yes** - If equipped with a roof rack, proceed to Step 2. For any other roof mounted accessories, please use the following link for instructions: [www.motorcraftservice.com/instructionsheets](http://www.motorcraftservice.com/instructionsheets).

**No** - Proceed to **LIFTGATE WINDOW GLASS REMOVAL**. (Page 11)

2. Remove the bolts and the cap from both sides of the front of the roof rack. See Figure 10.

- Torque: 5.9 lb.ft (8 Nm).

**NOTE:** Left Hand (LH) shown, Right Hand (RH) similar.

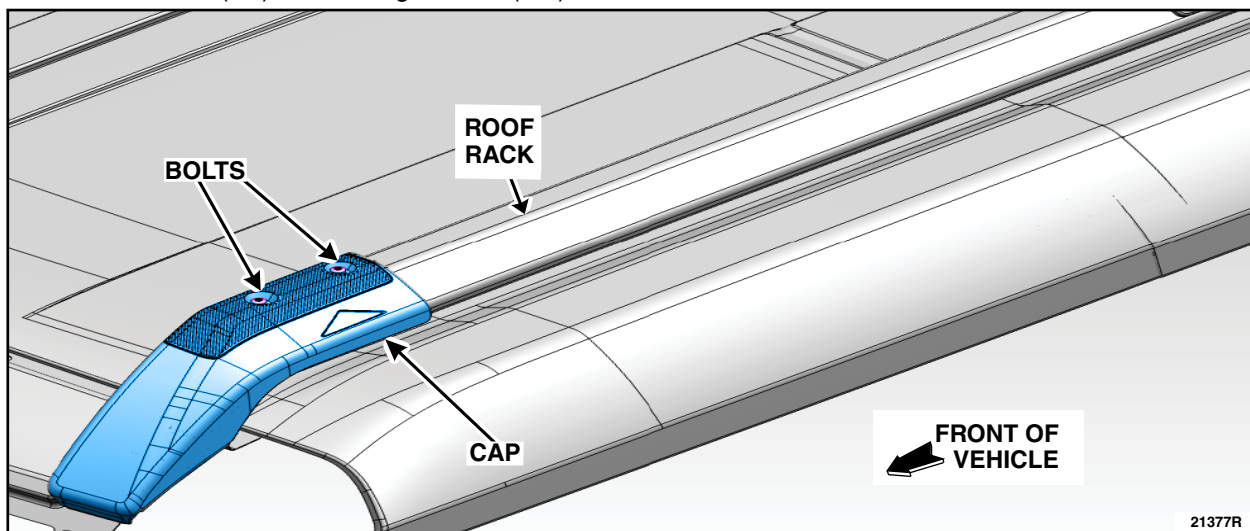

FIGURE 10



3. Remove the bolts from both sides of the front of the roof rack. See Figure 11.

- Torque: 7.7 lb.ft (10.5 Nm).

**NOTE:** LH shown, RH similar.

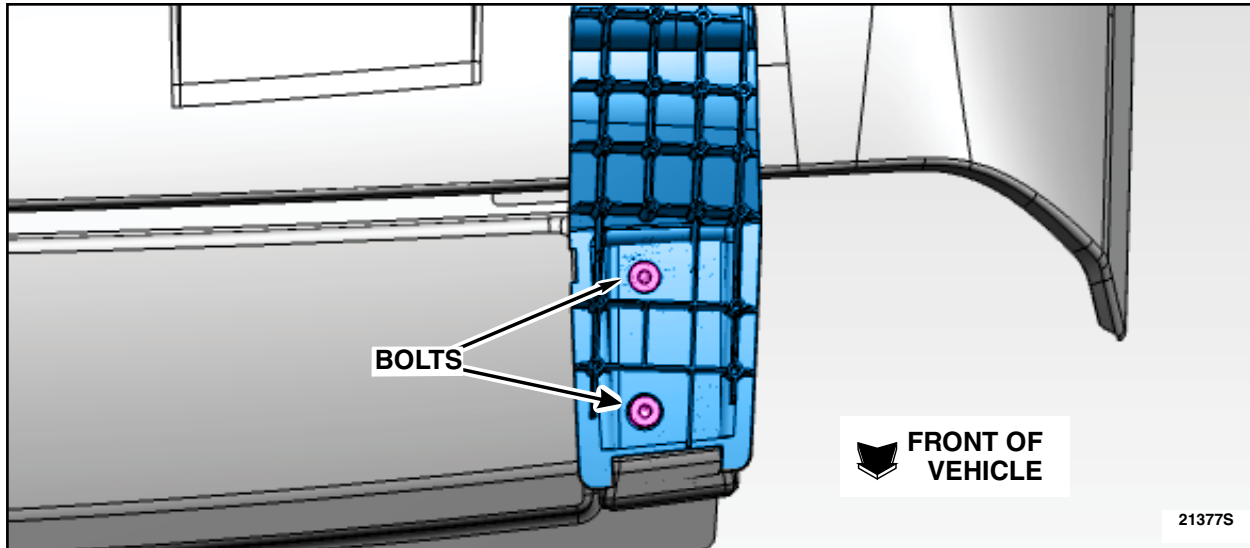
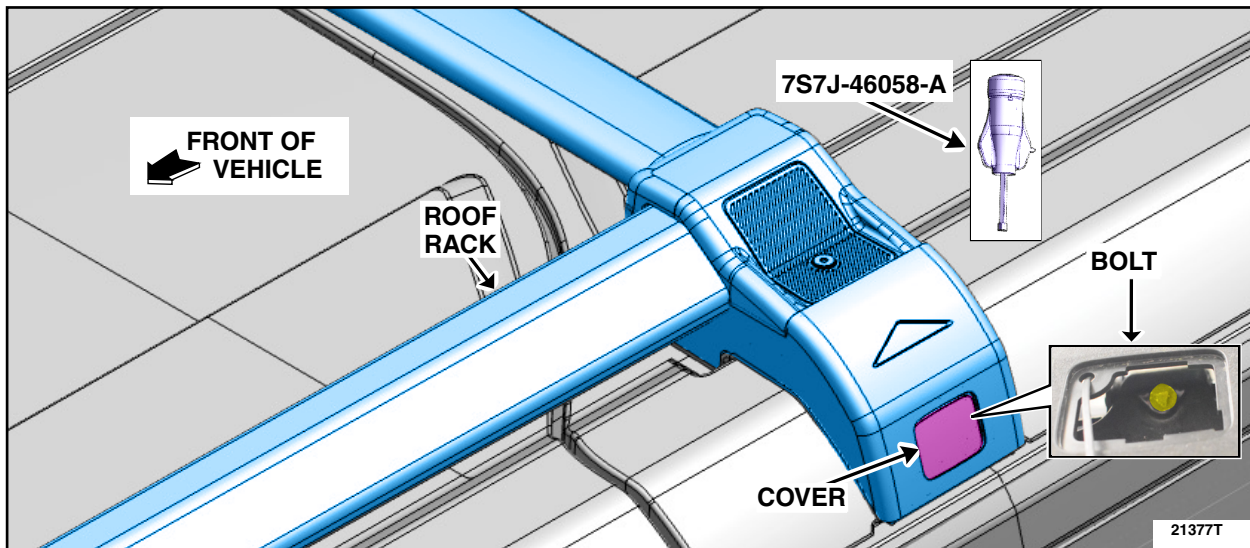

**FIGURE 11**

4. Remove the rear access cover and using the 7S7J-46058-A tool supplied with the roof rack kit (usually located in the glove box), loosen the bolt from both sides of the roof rack. See Figure 12.

**NOTE:** The 7S7J-46058-A tool is preset to the proper torque and will click once proper torque is achieved.

**NOTE:** LH shown, RH similar.



**FIGURE 12**



5. Lift up on the clamp on the rear of the roof rack, slide toward the front of the vehicle while lifting up and off the studs on the front of the vehicle to remove the roof rack assembly.

**NOTICE: Damage to the roof rack can occur if it is not stored properly before it is reinstalled.**

6. Place the roof rack assembly in a secure location until it is reinstalled on the *new* hard top assembly later in this procedure.



**FIGURE 13**



## LIFTGATE WINDOW GLASS REMOVAL

**NOTE:** The liftgate window glass must be transferred to the *new* rear hard top cap assembly.

1. Open the tailgate. See Figure 14.

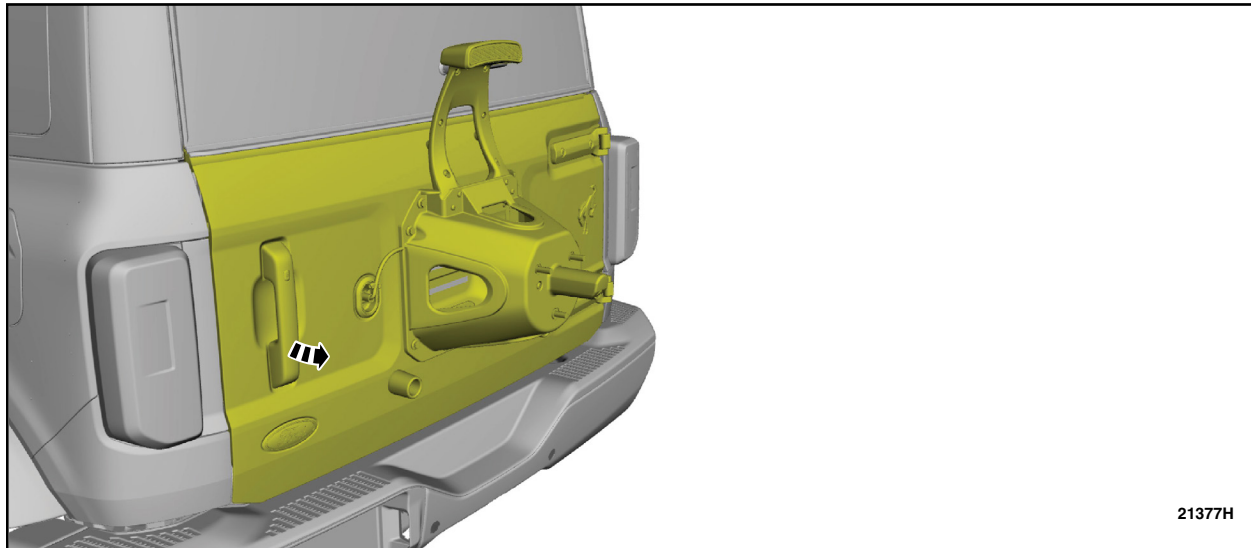

**FIGURE 14**

2. Open the liftgate window glass. See Figure 15.

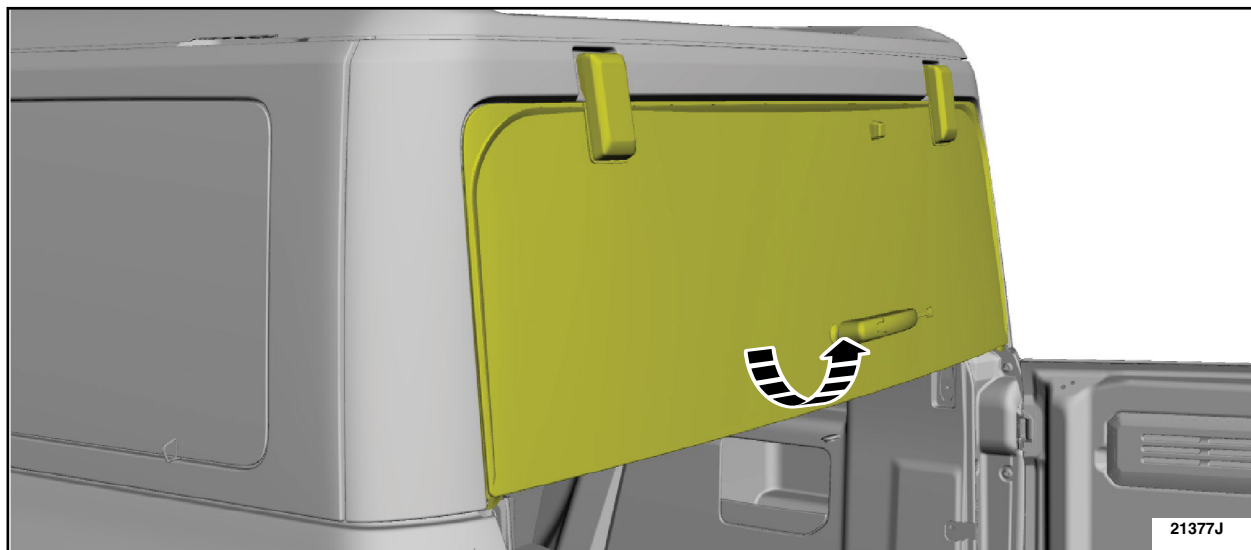

**FIGURE 15**





3. On both sides, disconnect the heated rear window element electrical connectors. See Figure 16.

**NOTE:** Liftgate window glass shown closed for clarity.

**NOTE:** LH shown, RH similar.



**FIGURE 16**

4. Disconnect the rear window washer hose. See Figure 17.

**NOTE:** Liftgate window glass shown closed for clarity.

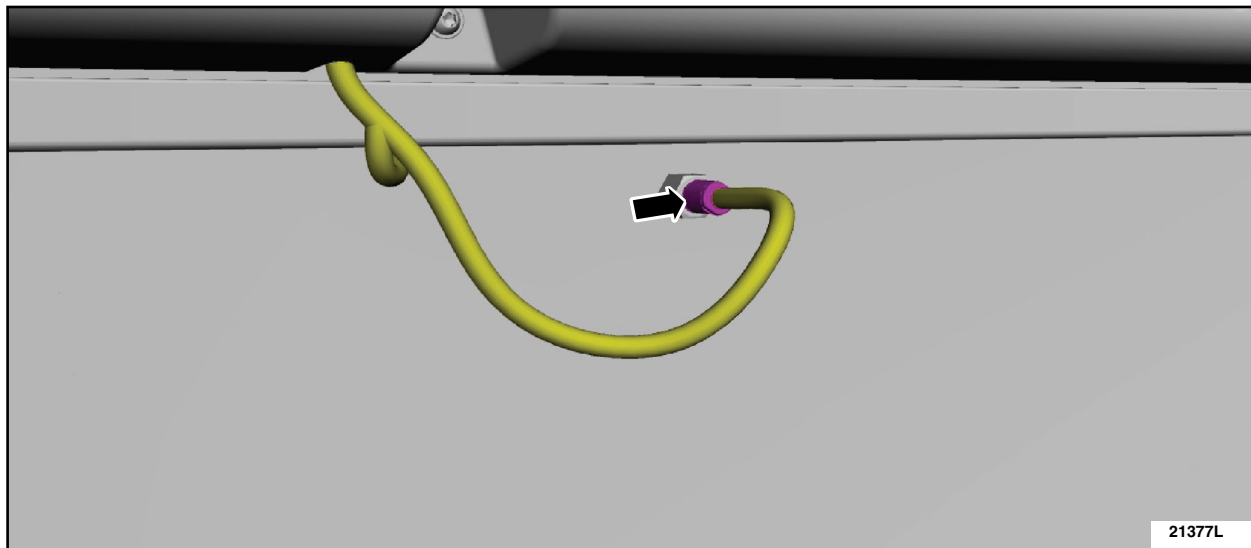

**FIGURE 17**



5. Remove the access cover located at the rear of the hard top rear cap assembly and disconnect the liftgate window glass electrical connector. See Figure 18.



FIGURE 18



6. On both sides release the clips and disconnect the rear liftgate window glass strut. See Figure 19.

1. Release the rear liftgate window glass strut clip.
2. Disconnect the rear liftgate window glass strut.

**NOTE:** Liftgate window glass shown closed for clarity.

**NOTE:** LH shown, RH similar

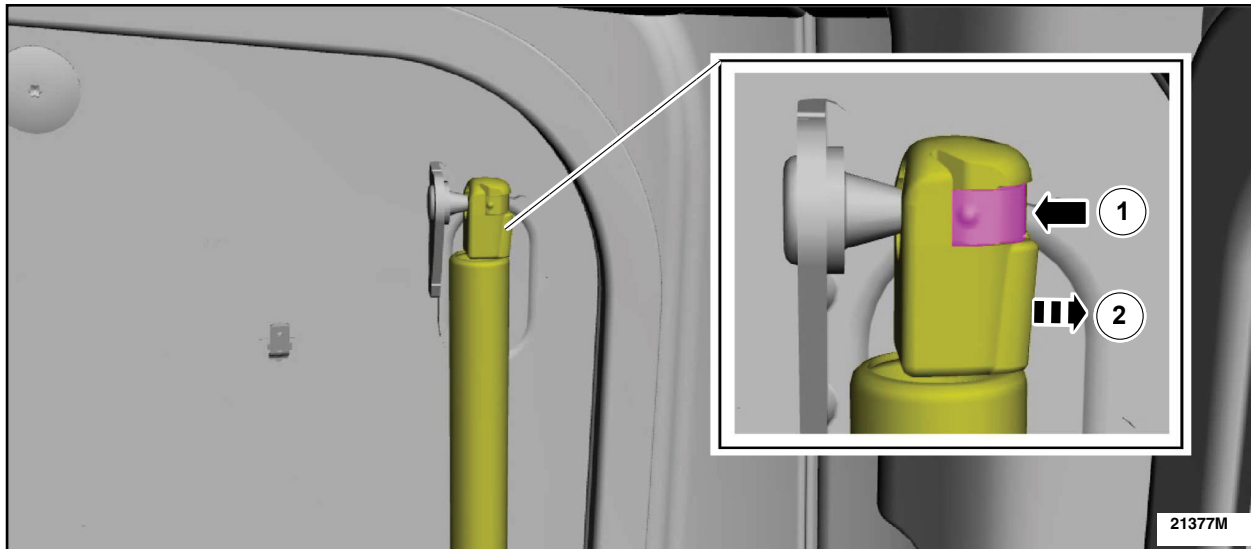

**FIGURE 19**

7. Release the liftgate window glass hinge trim covers. See Figure 20.

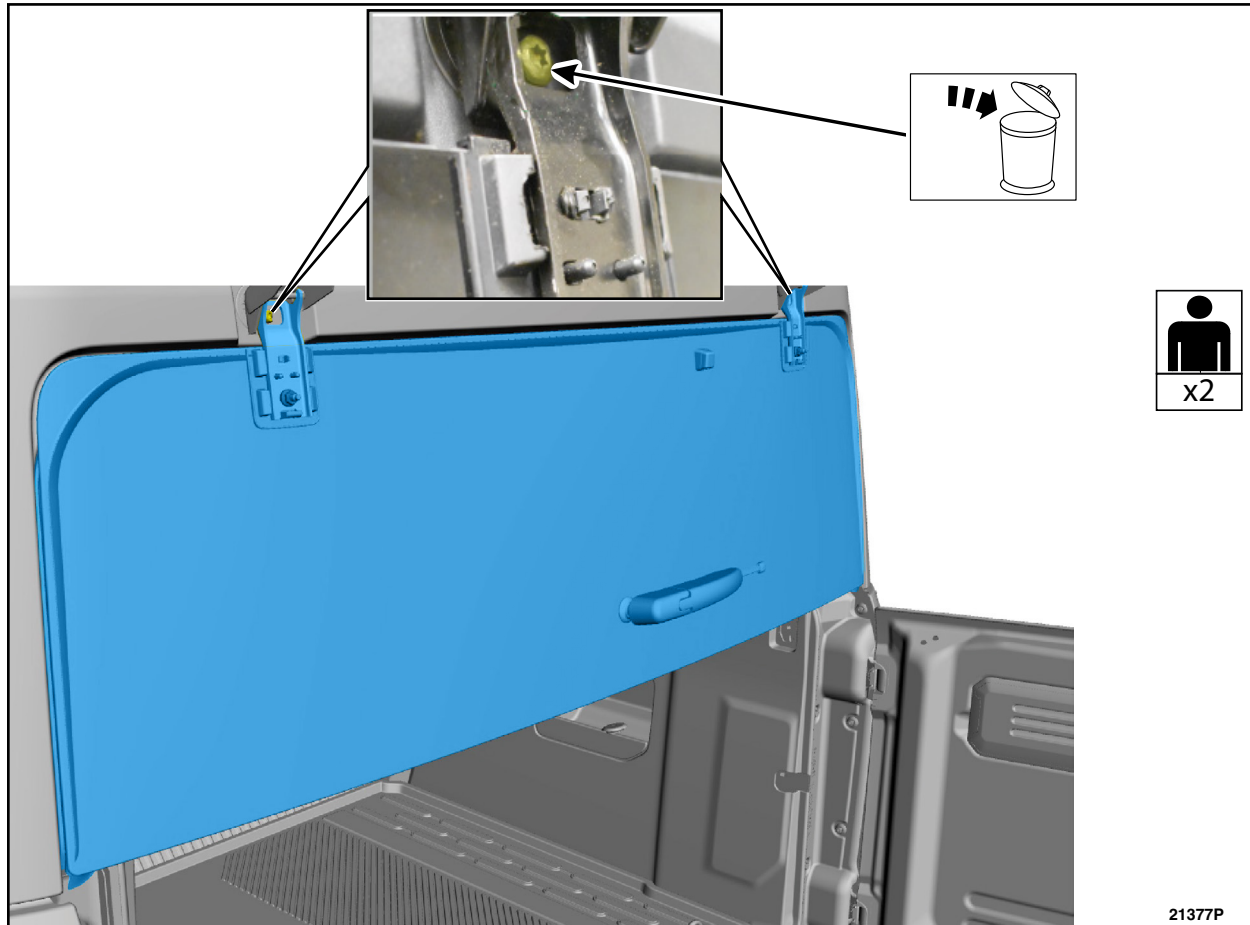

**FIGURE 20**



8. Remove and discard the two liftgate window glass hinge bolts, then remove the liftgate window glass. See Figure 21.

- Torque: 93 lb.in (10.5 Nm).



**FIGURE 21**

**NOTICE: Damage to the liftgate window glass can occur if it is not stored properly before it is reinstalled.**

9. Place the liftgate window glass in a secure location until it is reinstalled on the *new* hard top rear cap assembly later in this procedure.
10. Remove all Hard Top Panels and the Hard Top Rear Cap Assembly. Please follow Workshop Manual (WSM) procedures in section 501-18B.



## HARD TOP PANELS AND HARD TOP REAR CAP ASSEMBLY INSTALLATION

**NOTE:** Do not discard the push pins that retain the foam protective pads to the the bottom of the *new* hard top rear cap assembly.

**NOTE:** If originally equipped from the factory with the interior noise insulation headliner kit option, the *new* hard top roof panels and hard top rear cap assembly will come with the headliner already installed.

1. Remove the push pin retainers and the foam protective pads and install the *new* Hard Top Rear Cap Assembly. Please follow the WSM procedures in Section 501-18B.
2. For 5 door models only, install the *new* Hard Top Center Panel. Please follow the WSM procedures in Section 501-18B.
3. Install the *new* Hard Top Front Panel RH and the *new* Hard Top Front Panel LH. Please follow the WSM procedures in Section 501-18B.
4. Reinstall the liftgate window glass using the *new* hinge bolts included in the wooden crate kit. Complete by reversing the steps in the **LIFTGATE WINDOW GLASS REMOVAL** procedure. (Page 11)
5. If equipped, reinstall the roof rack. Complete by reversing the steps in the **Vehicle Present at the Dealer** section. (Page 8)
6. If equipped, reinstall any other roof mounted accessories. Please use the following link for instructions: [www.motorcraftservice.com/instructionsheets](http://www.motorcraftservice.com/instructionsheets).

**NOTE:** Steps 7 and 8 do not apply to dealers located in Alaska and Hawaii. Any parts replaced in in those states should be rendered physically unusable and scrapped.

7. Install the foam protective pads on the hard top rear cap assembly using the push pin retainers.
8. Using all the original shipping materials repack all the hard top roof panels and the hard top rear cap assembly. Reassemble the wood shipping crate using all the original screws and reinstall the waterproof plastic cover for return shipping.

**IMPORTANT NOTE:** Federal law prohibits selling motor vehicle parts or components that are under safety, compliance, or emissions recall. Unless a part is requested to be returned to Ford, all parts replaced under this FSA must be scrapped in accordance with all applicable local, state and federal environmental protection and hazardous material regulations. Refer to the Parts Retention, Return, & Scrapping section of the FSA dealer bulletin for further information.



## CERTAIN 2021 MODEL YEAR BRONCO EQUIPPED WITH A HARD TOP ROOF — ROOF PANEL DELAMINATION FIXED QUARTER GLASS

### FIXED QUARTER GLASS INSTALLATION

**NOTICE:** DO NOT leave the masking tape holding the glass in place for prolonged amount of time or exposed to direct sunlight. The mask tape must be removed between two and three hours after the glass installation and prior to returning the vehicle to the customer.

**CAUTION:** To prevent damage to the rear cap assembly, the *new* quarter glass should be installed while the *new* hard top rear cap assembly is flat and secure on top of the crate foam protective pads at all times.

1. Using a clean and dry lint-free cloth, wipe any contamination off the factory primer located on the hard top rear cap assembly quarter glass flanges and on both quarter glass. See Figure 3, on Page 3.

**⚠️ IMPORTANT!** The *new* hard top rear cap assembly and both quarter glass are pre-primed. The pre-priming is only good for 90 days from the build date.

2. Inspect the *new* hard top rear cap assembly and the *new* quarter glass labels to make sure the primer has not expired. See Figure 1.

- Is the primer expired (built date is 90 days old or more) or the label is missing?

**YES** - Proceed to Step 3.

**NO** - Proceed to Step 4.



FIGURE 1





**⚠ IMPORTANT:** Primer must be matched to the urethane adhesive (primer must be compatible with urethane being used).

**NOTE:** The use of disposable gloves and safety glasses is required.

**NOTE:** Proper placement of the primer is crucial to avoid appearance concerns. Do not allow the primer to cross into the visible portion of the glass. See Figure 2.

**NOTE:** Fixed quarter glass shown installed on the hard top rear cap assembly for clarity. The view is from the inside of the vehicle looking out. See Figure 2.

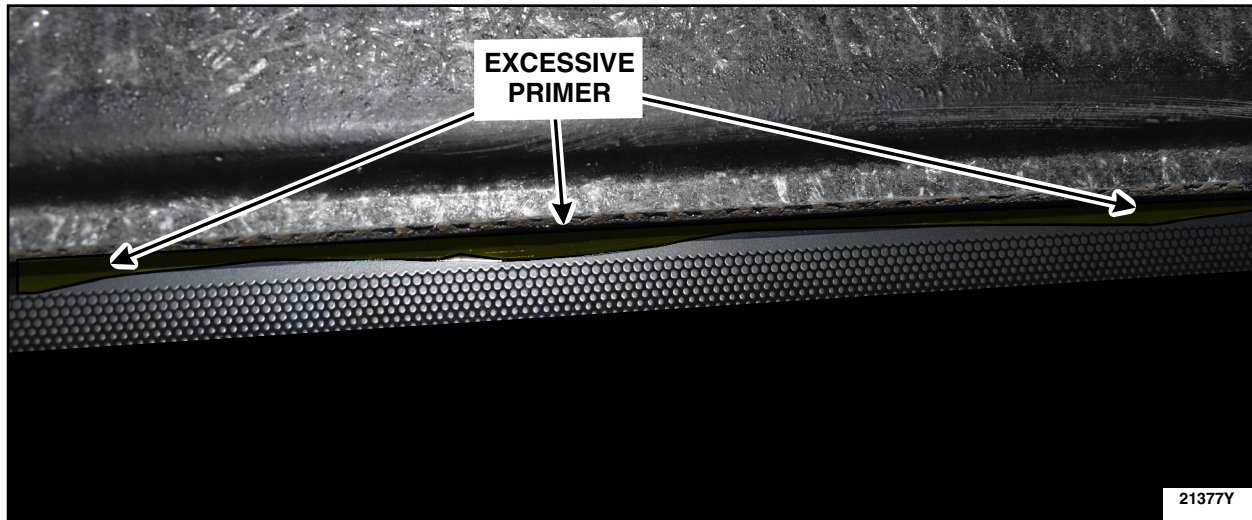

**FIGURE 2**

3. Carefully apply some Sika® Primer-207, Sika® Aktivator PRO or Dow® BETAPRIME™ 5504G primer to the *new* hard to rear cap assembly quarter window glass flanges and to both *new* quarter glass on top of the existing black primer. Minimize applying primer only over the existing black factory primer and allow at least 10 minutes to dry. See Figure 3.

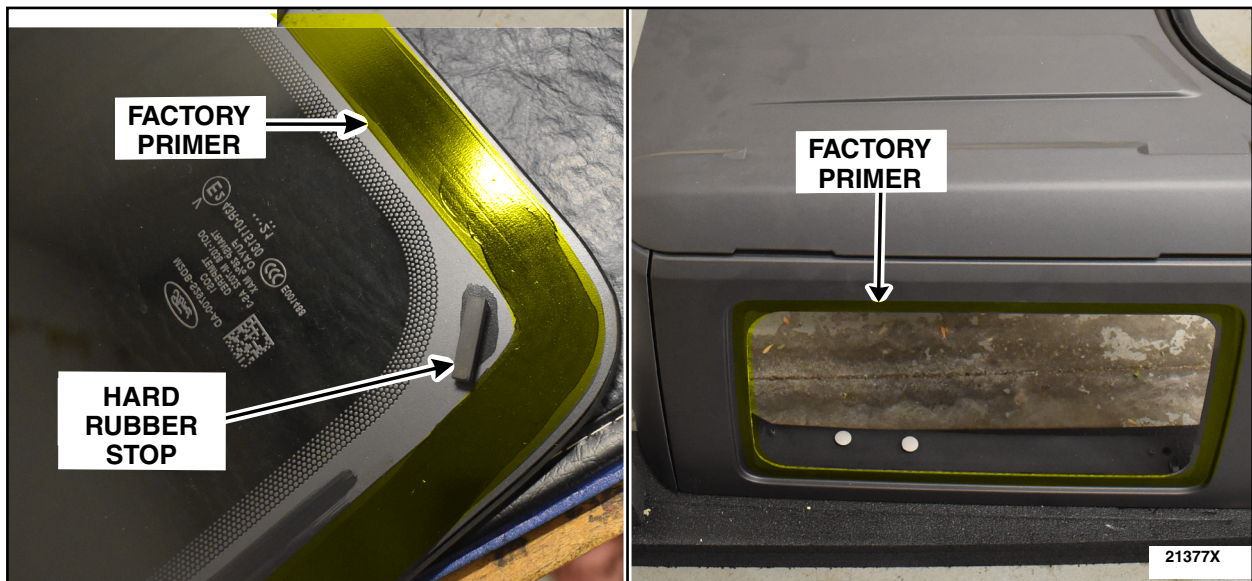
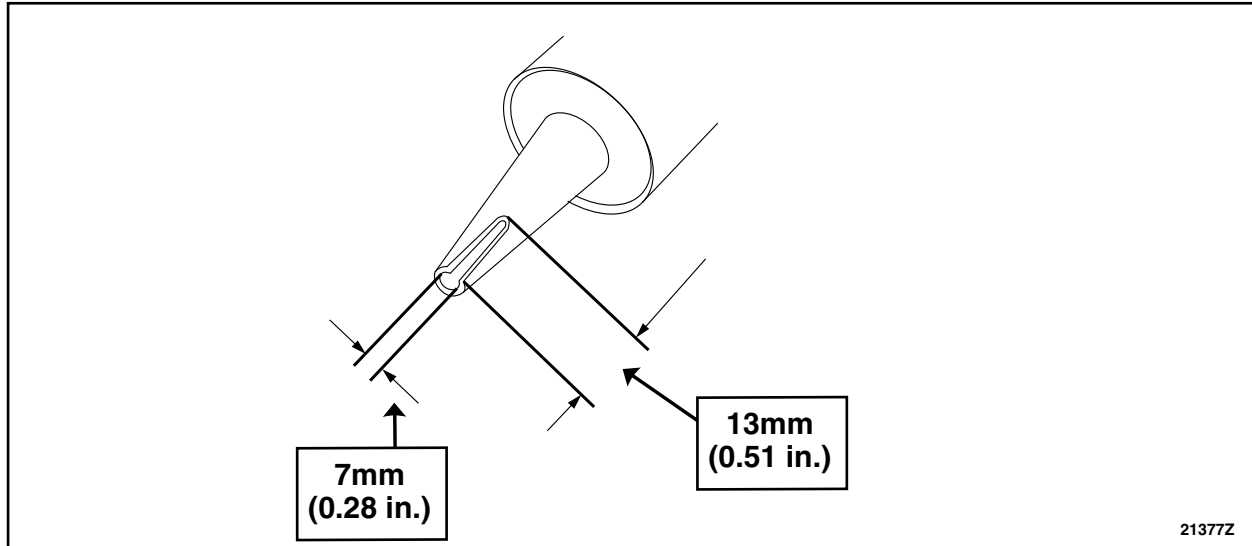

**FIGURE 3**



**NOTE:** For ease of application, it is recommended to warm up the tube of urethane adhesive.

4. Cut the urethane adhesive applicator tip in triangular shape, to specification. See Figure 4.



**FIGURE 4**

**NOTICE:** Make sure there are no gaps in the urethane bead and that the bead is uniform to prevent air and water leaks.

**NOTE:** The *new* quarter glass must be installed within 10 minutes of applying the urethane adhesive.

**NOTE:** Using a power caulk gun helps to apply the urethane adhesive with less effort and with a continuous bead.

**NOTE:** Proper placement and application of the urethane is crucial to avoid appearance concerns.





5. Using a mechanical or power caulk gun, apply some SikaTack® (MACH 60/MACH 30) or Dow® BETASEAL™ Express urethane in a triangular bead 7mm (0.28 in) wide by 13mm (0.51 in) high in the center the primed surface of the *new* hard top rear cap assembly quarter window glass flanges and overlap the bead along front edge of *new* hard top rear cap assembly quarter window glass flanges. The position of the urethane bead should be 14mm (0.55 in) from the outer edge of the *new* hard top rear cap assembly flange to the bead. See Figures. See Figures 5 and 6.

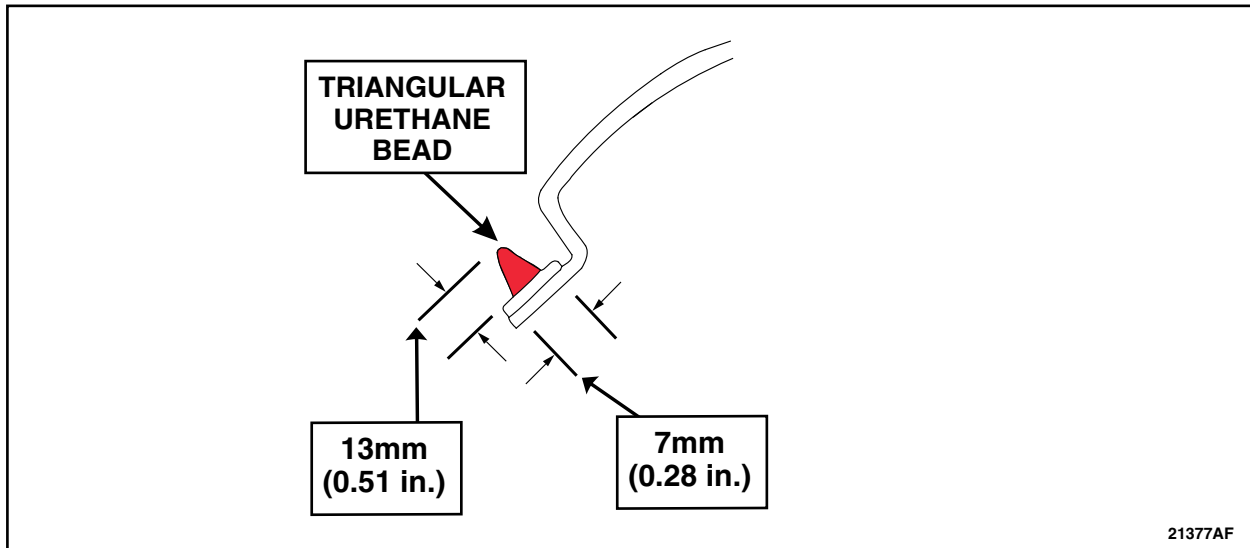

FIGURE 5

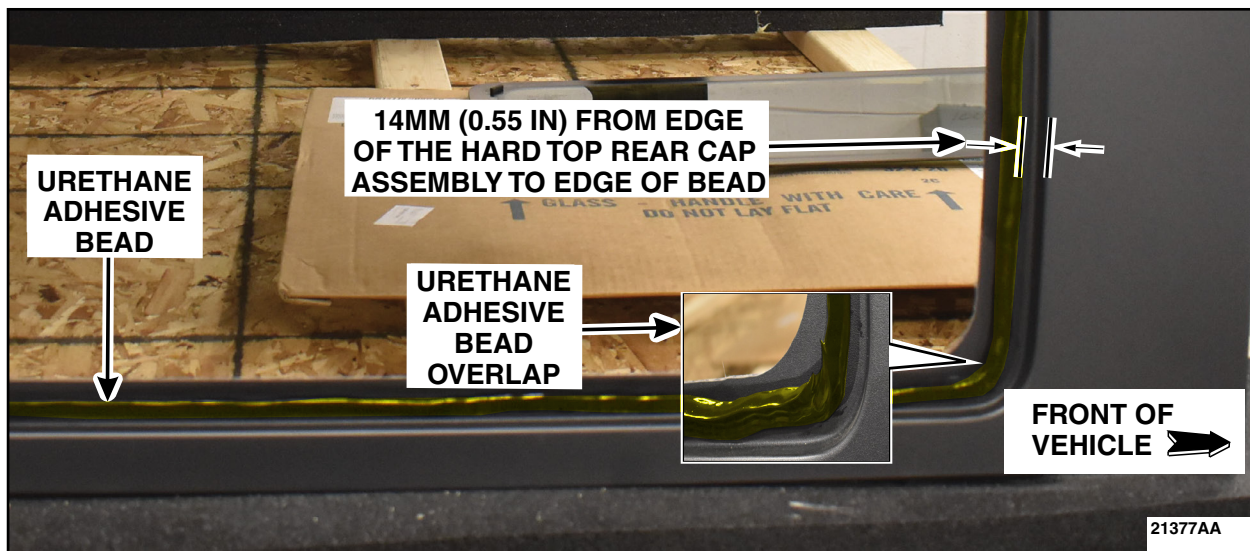

FIGURE 6

**⚠ WARNING:** Improper curing of the urethane adhesive may adversely affect glass retention, which is important for restraint system performance during a crash. Carefully follow the urethane adhesive manufacturer's curing instructions. Do not drive the vehicle until the urethane adhesive seal has cured. Failure to follow these instructions may result in serious injury to vehicle occupant(s) during a crash.

**NOTICE:** Brace by hand the lower portion of the *new* hard top rear cap assembly while pressing the *new* quarter glass into place to prevent damage to the cap assembly.



6. On both sides, install the *new* quarter glass into the *new* hard top rear cap assembly opening, centering the glass in the opening by eye, and pushing it in to the hard rubber stops at the corners to set the depth (flushness). The quarter glass should have about a 3mm (0.12 in) margin to the *new* hard top rear cap assembly all around.

**NOTE:** When installed, the *new* quarter glass will be under flush with the *new* hard top rear cap assembly.

**NOTE:** As needed, wash excess urethane adhesive using Motorcraft® Ultra-Clear Spray Glass Cleaner (ZC-23).

7. Using 50mm (2 in) wide masking tape, secure the *new* quarter glass to the *new* hard top rear cap assembly while the urethane cures. Ensure there is an even 3mm (0.12) gap all the way around the quarter glass. See Figure 7.

**NOTICE:** **DO NOT** leave the masking tape holding the glass in place for a prolonged amount of time or exposed to direct sunlight. **The masking tape must be removed between two and three hours after the glass installation and prior to returning the vehicle to the customer.**

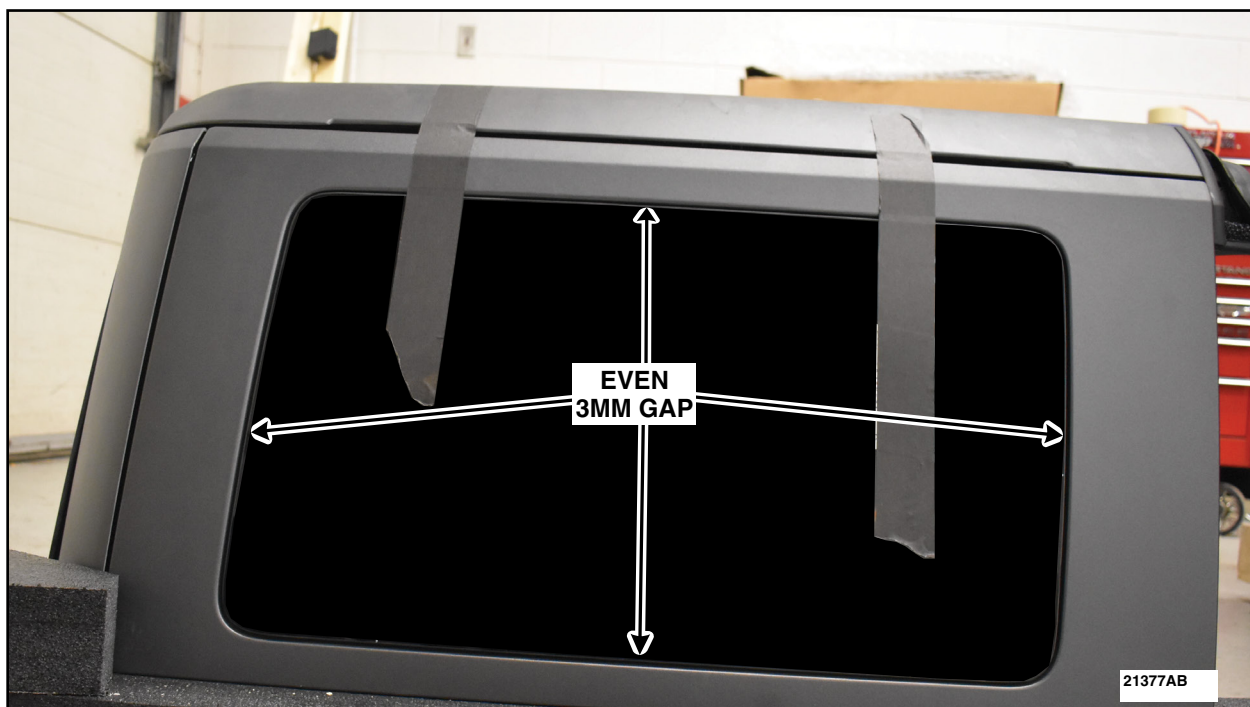

**FIGURE 7**

8. After the masking tape has been removed, ensure there is no tape residue remaining on the surfaces.





Ford Motor Company  
Ford Customer Service Division  
P. O. Box 1904  
Dearborn, Michigan 48121

October 2021

## Customer Satisfaction Program 21B49

Mr. John Sample  
123 Main Street  
Anywhere, USA 12345

Your Vehicle Identification Number (VIN): 12345678901234567

At Ford Motor Company, we are committed not only to building high quality, dependable products, but also to building a community of happy, satisfied customers. To demonstrate that commitment, we are providing a no-charge Customer Satisfaction Program for your Bronco with the VIN shown above.

- Why are you receiving this notice?** On your vehicle, it may be possible that there is an exposed or unsealed hard top roof panel edge that may allow water or humidity to be absorbed by the hard top panel.
- What is the effect?** This may cause unsatisfactory appearance if exposed to extreme water and humidity. This concern is strictly an appearance issue as the function of the roof is uncompromised.
- What will Ford and your dealer do?** **Parts are now available to repair your vehicle.** In the interest of customer satisfaction, Ford Motor Company has authorized your dealer to replace all the hard top roof panels and install new rear quarter glass in the new rear cap on your vehicle free of charge (parts and labor) under the terms of this program. The liftgate window glass and if equipped, the roof rack and/or other roof mounted accessories will be transferred to the new roof assembly. This Customer Satisfaction Program will be in effect until September 30, 2022 regardless of mileage. Coverage is automatically transferred to subsequent owners.
- How long will it take?** The time needed for this repair is less than one-half day. However, due to service scheduling requirements, your dealer may need your vehicle for a longer period of time.
- What should you do?** Please call your dealer without delay to schedule a service appointment for Customer Satisfaction Program 21B49. Provide the dealer with your VIN, which is printed near your name at the beginning of this letter.  
**Note:** Please ensure that all original factory hard top parts are installed on the vehicle prior to your appointment.

**What should you do?  
(continued)**

If you do not already have a servicing dealer, you can access [owner.ford.com](http://owner.ford.com) for dealer addresses, maps, and driving instructions.

Ford Motor Company wants you to have this service action completed on your vehicle. The vehicle owner is responsible for making arrangements to have the work completed.

NOTE: You can receive information about Recalls and Customer Satisfaction Programs through our FordPass App. The app can be downloaded through the App Store or Google Play. In addition there are other features such as reserving parking in certain locations and controlling certain functions on your vehicle (lock or unlock doors, remote start) if it is equipped to allow control.

**COVID-19  
(CORONAVIRUS)**

Ford dealerships have implemented enhanced protocols to ensure both your safety and the safety of dealership employees. This includes specific procedures for cleaning and disinfecting customer vehicles before and after each vehicle is serviced. In most places, vehicle service has been deemed a critical service. Please contact your local dealer to confirm current service hours. For more information on how Ford and your local dealer are working hard to keep you on the road during these challenging times, please visit [owner.ford.com](http://owner.ford.com).

**What if you no longer own this vehicle?**

If you no longer own this vehicle, and have an address for the current owner, please forward this letter to the new owner.

You received this notice because our records, which are based primarily on state registration and title data, indicate that you are the current owner.

**Can we assist you further?**

If you have difficulties getting your vehicle repaired promptly and without charge, please contact your dealership's Service Manager for assistance.

**RETAIL OWNERS:** If you have questions or concerns, please contact our **Ford Customer Relationship Center at 1-866-436-7332** and one of our representatives will be happy to assist you. If you wish to contact us through the Internet, our address is: [owner.ford.com](http://owner.ford.com)

For the hearing impaired call 1-800-232-5952 (TDD). Representatives are available Monday through Friday: 8:00AM – 8:00PM (Eastern Time).

**FLEET OWNERS:** If you have questions or concerns, please contact our **Fleet Customer Information Center at 1-800-34-FLEET**, choose Option #3, and one of our representatives will be happy to assist you. If you wish to contact us through the Internet, our address is: [fleet.ford.com](http://fleet.ford.com).

Representatives are available Monday through Friday: 8:00AM - 8:00PM (Eastern Time).

Thank you for your attention to this important matter.

Ford Customer Service Division