

**Subject:**

**WHISTLING NOISE FROM FRONT WINDOW GLASS WHEN  
DRIVING AT HIGHWAY SPEED**

**Bulletin No.: 09-028/21**

**Last Issued : 09/17/2021**

**APPLICABLE MODEL(S)/VINS**

2017-2021 CX-5

**DESCRIPTION**

Some customers may complain about a whistling noise heard from the top of the A-pillar area when driving at highway speeds.



When driving under following conditions, a negative pressure is generated on the doors pulling them outward and resulting in weatherstrip vibration.

- The vehicle is exposed to a side wind while driving at highway speeds.
- The vehicle is exposed to a strong side wind while driving at a speed slightly higher than highway speed.

Customers having this concern should have their vehicle repaired using the following repair procedure.

**REPAIR PROCEDURE**

1. Verify the customer concern.
2. Remove the upper-side front door weatherstrip.

**NOTE:** Use a fastener remover and remove the fasteners in the order shown below.

**CONSUMER NOTICE:** The information and instructions in this bulletin are intended for use by skilled technicians. Mazda technicians utilize the proper tools/ equipment and take training to correctly and safely maintain Mazda vehicles. These instructions should not be performed by "do-it-yourselfers." Customers should not assume this bulletin applies to their vehicle or that their vehicle will develop the described concern. To determine if the information applies, customers should contact their nearest authorized Mazda dealership. Mazda North American Operations reserves the right to alter the specifications and contents of this bulletin without obligation or advance notice. All rights reserved. No part of this bulletin may be reproduced in any form or by any means, electronic or mechanical--including photocopying and recording and the use of any kind of information storage and retrieval system ---without permission in writing.

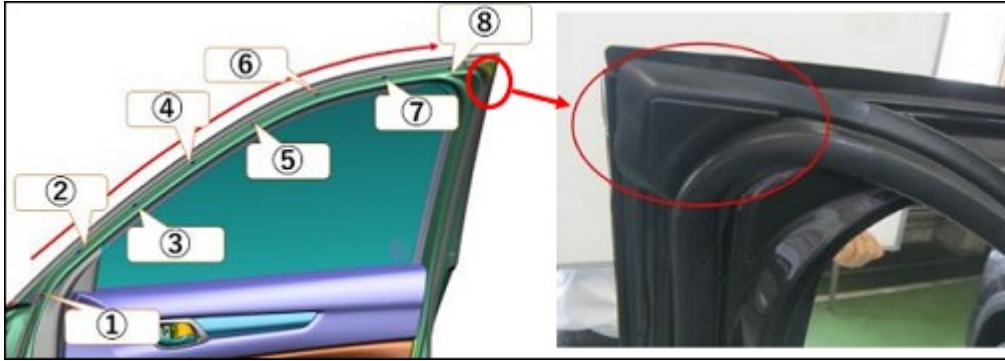

**NOTE:** Do not remove the fastener in the corner (indicated by the red circle above/right, p/n KB7W-5\*-762), as it could break.

3. Remove any grease or dust from the surface where the weatherstrip was attached.

4. Attach the pads next to the front doors hem:

a) Attach the longest pad (t2.4 x w4 x L1000mm) as shown below.

- Start attaching from the front side, 120mm away from the sash molding tip (1).

- While attaching the pad, it may wander, so initially attach the pad lightly and after the whole length of the pad is positioned, press it down against the hem for a firm bonding (2).

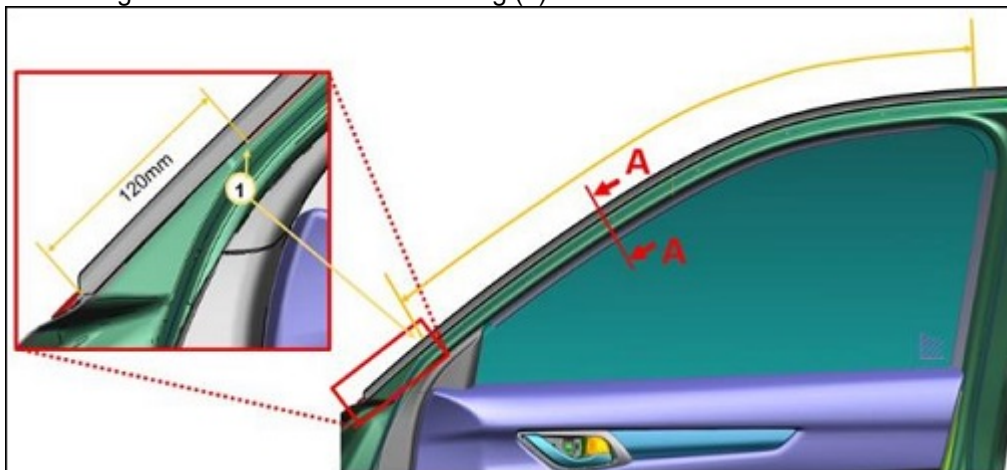

SEC. A-A

**CONSUMER NOTICE:** The information and instructions in this bulletin are intended for use by skilled technicians. Mazda technicians utilize the proper tools/ equipment and take training to correctly and safely maintain Mazda vehicles. These instructions should not be performed by "do-it-yourselfers." Customers should not assume this bulletin applies to their vehicle or that their vehicle will develop the described concern. To determine if the information applies, customers should contact their nearest authorized Mazda dealership. Mazda North American Operations reserves the right to alter the specifications and contents of this bulletin without obligation or advance notice. All rights reserved. No part of this bulletin may be reproduced in any form or by any means, electronic or mechanical---including photocopying and recording and the use of any kind of information storage and retrieval system ---without permission in writing.

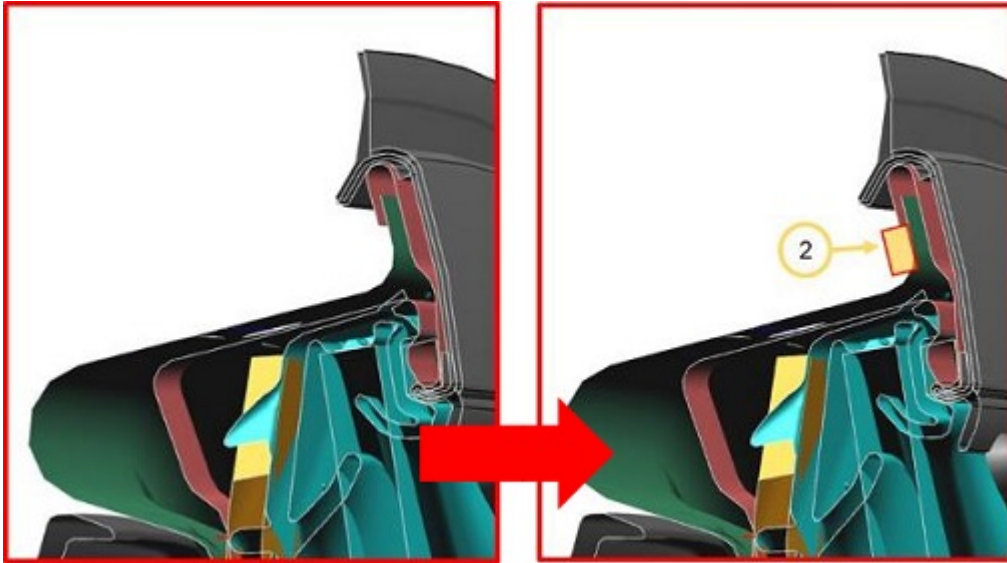

Examples of Poor Pad Attachment (3 and 4)

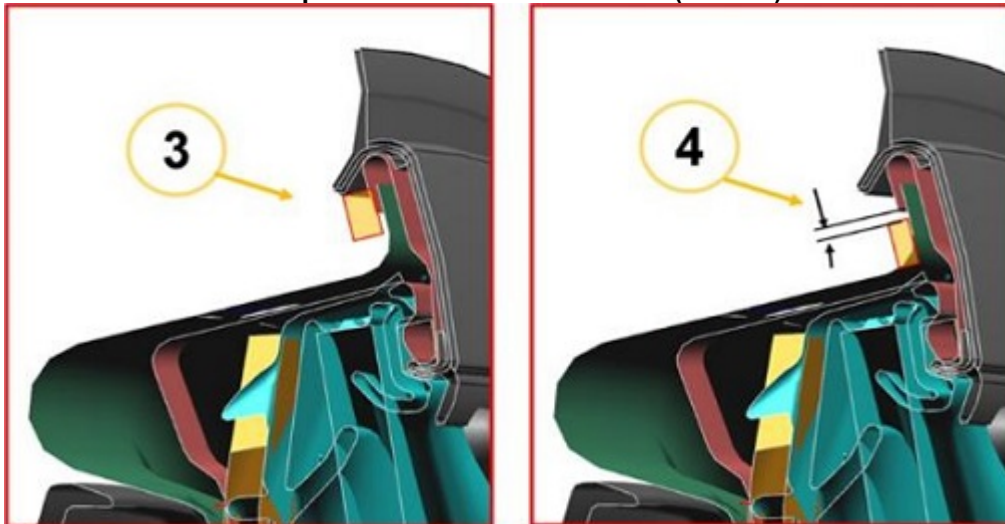

- b) Attach pad (t1.9 x w4 x L300) onto the long pad installed in step a above.
- Use fastener No. 4 position (1) as a reference for the attachment starting point.
  - While attaching the pad, it may wander, so initially attach the pad lightly and after the pad is positioned, press it for final bonding (2).

**CONSUMER NOTICE:** The information and instructions in this bulletin are intended for use by skilled technicians. Mazda technicians utilize the proper tools/ equipment and take training to correctly and safely maintain Mazda vehicles. These instructions should not be performed by "do-it-yourselfers." Customers should not assume this bulletin applies to their vehicle or that their vehicle will develop the described concern. To determine if the information applies, customers should contact their nearest authorized Mazda dealership. Mazda North American Operations reserves the right to alter the specifications and contents of this bulletin without obligation or advance notice. All rights reserved. No part of this bulletin may be reproduced in any form or by any means, electronic or mechanical---including photocopying and recording and the use of any kind of information storage and retrieval system ---without permission in writing.

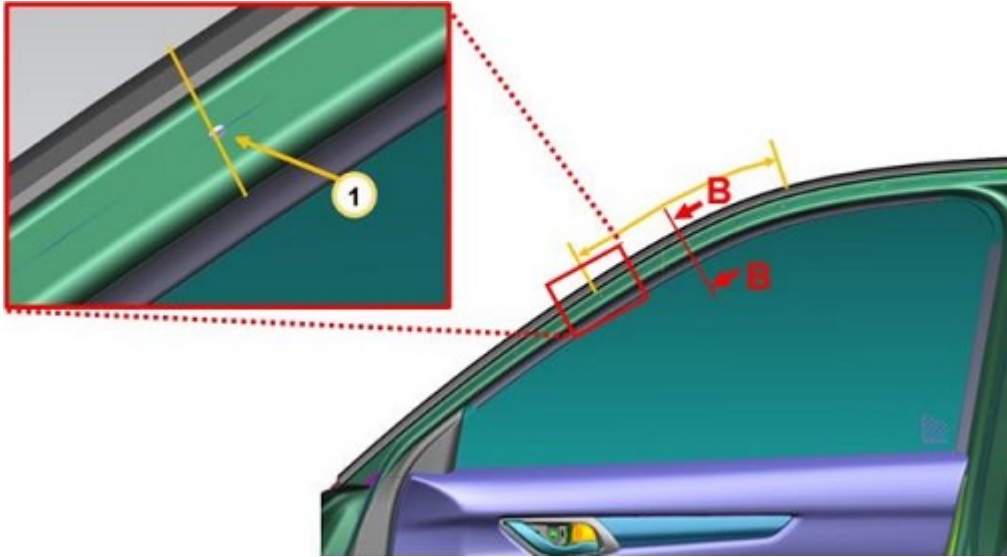

SEC. B-B

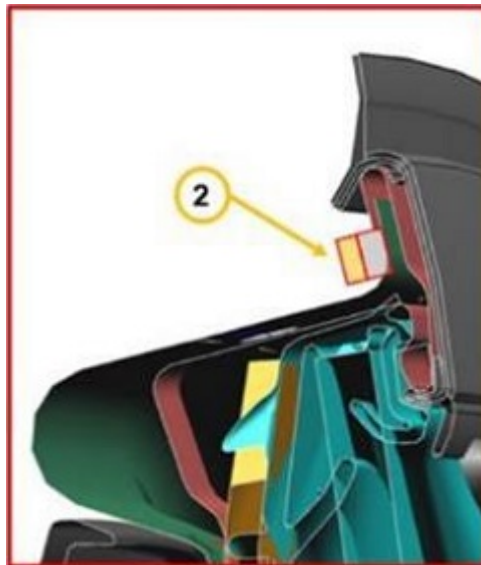

5. Reinstall the weatherstrip with the fasteners (BC1D-58-762).  
**NOTE:** If the fasteners are damaged, replace them with new ones.
6. Repeat steps 2 - 5 for the other side front door.
7. Verify the whistling noise is gone.

**PARTS INFORMATION**

Parts Number	Description	Qty.	Notes
--------------	-------------	------	-------

**CONSUMER NOTICE:** The information and instructions in this bulletin are intended for use by skilled technicians. Mazda technicians utilize the proper tools/ equipment and take training to correctly and safely maintain Mazda vehicles. These instructions should not be performed by "do-it-yourselfers." Customers should not assume this bulletin applies to their vehicle or that their vehicle will develop the described concern. To determine if the information applies, customers should contact their nearest authorized Mazda dealership. Mazda North American Operations reserves the right to alter the specifications and contents of this bulletin without obligation or advance notice. All rights reserved. No part of this bulletin may be reproduced in any form or by any means, electronic or mechanical---including photocopying and recording and the use of any kind of information storage and retrieval system ---without permission in writing.

KBY0-58-769	Pad	1	Includes pads for both sides
BC1D-58-762	Fastener	(Max. 16)	Replace if broken during the repair
KB7W-58-762	Fastener	1	For right side front door: Replace only if broken during the repair*
KB7W-59-762	Fastener	1	For left side front door: Replace only if broken during the repair*

\*Fasteners KB7W-58-762 and KB7W-59-762 are not supposed to be removed during the repair.

## WARRANTY INFORMATION

### NOTE:

- This warranty information applies only to verified customer complaints on vehicles eligible for warranty repair.
- This repair will be covered under Mazda's New Vehicle Limited Warranty term.
- Additional diagnostic time cannot be claimed for this repair.

Warranty Type	A
Symptom Code	82
Damage Code	97
Part Number Main Cause	KBY0-58-769
Quantity	1
Operation Number / Labor Hours:	XXS6CXRX / 0.6 Hrs.

**CONSUMER NOTICE:** The information and instructions in this bulletin are intended for use by skilled technicians. Mazda technicians utilize the proper tools/ equipment and take training to correctly and safely maintain Mazda vehicles. These instructions should not be performed by "do-it-yourselfers." Customers should not assume this bulletin applies to their vehicle or that their vehicle will develop the described concern. To determine if the information applies, customers should contact their nearest authorized Mazda dealership. Mazda North American Operations reserves the right to alter the specifications and contents of this bulletin without obligation or advance notice. All rights reserved. No part of this bulletin may be reproduced in any form or by any means, electronic or mechanical---including photocopying and recording and the use of any kind of information storage and retrieval system ---without permission in writing.