

Hide Details

Coding Information

| | | | | | | | |
|----------------------|-------------------------------|--|-----------------------------|------------------|-----------------------------|--------------------------|-----------------------------|
| Copy Link | Copy Relative Link | Bookmark View My Bookmarks | Add to Favorites | Print | Provide Feedback | Helpful 19 | Not Helpful 0 |
|----------------------|-------------------------------|--|-----------------------------|------------------|-----------------------------|--------------------------|-----------------------------|

Title: QLS Emergency Calibration

Applies To: EPA 2017 and Newer X15 / L9 / B6.7 Engines

CHANGE LOG

Please refer to the change log text box below for recent changes to this article:

09/28/2021 - Update repair procedure to include cutting QLS pigtail, added FAQ, updated photos
 09/21/2021 - Added EPA 2017 B6.7 engines
 09/16/2021 - Initial Article Release

DESCRIPTION

This document is intended for information purposes only to inform the user about an emergency calibration release that has been approved by the EPA and CARB to help provide relief from the global supply shortage of electrical components.

The purpose of this calibration is to provide a short term calibration strategy that will allow vehicle operation with a failed DEF head unit / Quality Level Sensor (QLS). Any vehicle that receives the emergency calibration will eventually be required to have it rolled back to a production level calibration and a new QLS installed once parts become available, this will be managed through future communication.

Any vehicle that receives this calibration will continue to require a QLS unit to be installed and DEF fluid to operate. The changes are only to the strategies for the failure detection methods (outlined below under calibration identification section). It is also required that the customer letter documentation linked in the Cummins TRP and the Navistar reference sheet [4328818R1](#) be printed and placed in the vehicle prior to the vehicle going back into service. It is also strongly recommended that the driver be informed to the changes in the DEF gauge operation as outlined in the required documentation.

SYMPTOM(s)

Diagnostic Trouble Code(s) & Dashboard Indicator Light(s):

| Cummins DTC/Light | Description |
|-----------------------------------|---|
| 0-SPN3364-09 (Cummins Fault 3868) | Aftertreatment Diesel Exhaust Quality - Abnormal Update Rate |
| 0-SPN3031-09 (Cummins Fault 4572) | Aftertreatment Diesel Exhaust Tank Temperature - Abnormal Update Rate |
| 0-SPN1761-09 (Cummins Fault 4677) | Aftertreatment Diesel Exhaust Fluid Tank Volume: Abnormal Update Rate |

WARNING:

The EPA and CARB has only granted Navistar limited use of the QLS emergency calibration as it applies to the faults listed in the table above and diagnostic steps outlined in this article. The use of this calibration in any other circumstances could be considered tampering of an emission level component.

CALIBRATION IDENTIFICATION

Calibration Cross Reference Table:

*For Cummins powered vehicles refer to [TSB210187](#)

With a Production Calibration:

When the ECM detects a fault associated with the SCR system tampering logic the engine warning light will be turned on. After one hour of operation with the fault active the vehicle will enter a 25% de-rate. After 5 hours of operation with the fault active the vehicle will enter a 5mph de-rate. In some cases with the SCR inducement faults active, an SCR reset will be required with the service tool.

With the QLS Emergency Calibration:

The ECM will still log the QLS communication faults listed above, however it will not have any driver notification through a MIL or a de-rate reaction. The ECM will still follow the same de-rate strategy for all other faults, including all other QLS faults. Therefore, this calibration is not approved for any vehicle with faults other than the ones listed above.

The function of the different DEF head unit sensors are being handled by other means.

- DEF Quality will be monitored through SCR conversion efficiency
- DEF Tank thaw strategy will be through the ambient air temp
- DEF Tank empty will be determined by the ability of the DEF system to prime
- DEF Tank level will NOT function

With the DEF gauge not functioning the DEF Tank Miles to Empty will not read correctly or read N/A. It is strongly recommended that the vehicle be filled with DEF at every full stop to ensure the tank stays topped off.

Depending on the DLB parameter setting the cluster may produce an audible alarm for low DEF level. The default setting is set to "No Alarm", if the parameter has been changed it will need to be returned to the original setting of "No Alarm". See figure #9 in the DEF cluster alarm section below

CAUTION:

The DEF tank level gauge will NOT function with the QLS emergency calibration. It may show incorrect or empty at all times.

Note:

With the QLS emergency calibration the QLS communication faults will still be visible in Insite. However, they will not be broadcasted to displayed in the cluster or in health reports. With the QLS emergency calibration installed, these fault codes should be ignored.



Figure 1: DEF Level Gauge Reaction

Item 1: DEF Level Gauge

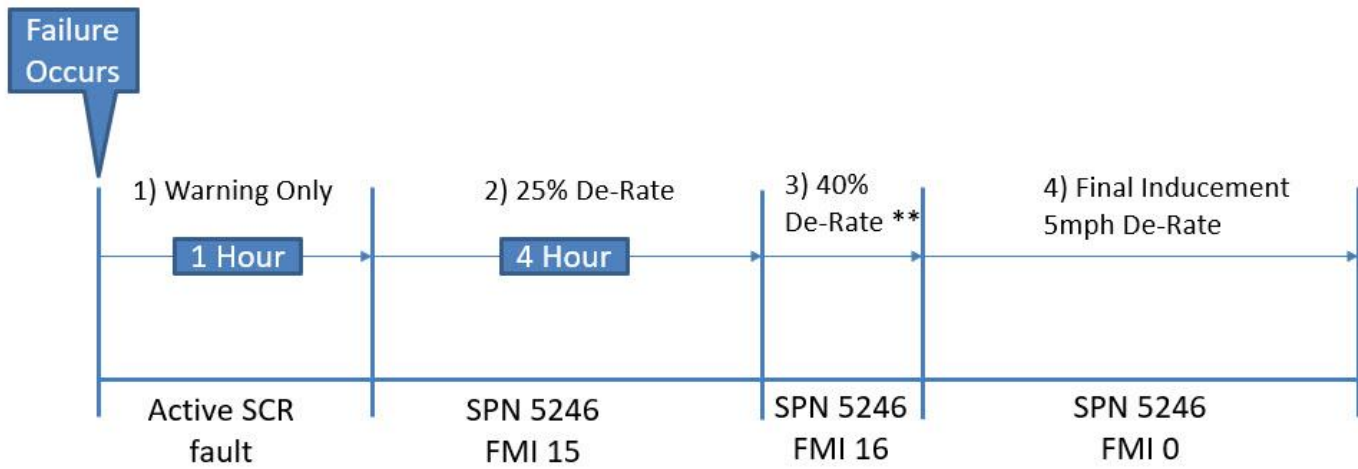

Figure 2: SCR System Tampering Inducement Faults

Item 1: For the first hour after a failure or tampering occurs there is a warning only, with no de-rate.

Item 2: Hour 1 to hour 5 there will be a 25% de-rate accompanied with fault code SPN 5246-15 AFT SCR operator inducement severity - Least severe.

Item 3: After 5 hours from initial awareness the vehicle will ramp to 40% de-rate and will search for the final inducement trigger accompanied with fault code SPN 5246-16 AFT SCR operator inducement severity - Moderately severe.

Item 4: Once final inducement is triggered the vehicle will ramp to a 5mph de-rate accompanied with fault code SPN 5246-0 AFT SCR operator inducement severity - Most severe.

Note: **The time between stage 3 and 4 will be determined based on the fault code and triggers. If repeated tampering occurs the time window between stages will be reduced.

SPECIAL TOOL(S) / SOFTWARE

| Tool Description | Tool Number | Comments | Instructions |
|--------------------|-------------|-------------------------|-----------------------------|
| Cummins Insite Pro | Software | Fleet Count is required | Refer to Cummins TRP# T2489 |

CALIBRATION REQUIRED SERVICE PARTS INFORMATION

| Part Number | Part Description | Quantity Needed | Notes |
|-------------|-------------------------|-----------------|---------------|
| 2644000R1 | Heat Shrink Tubing 50mm | 4 | Or equivalent |
| 306132C1 | Tie Strap | 1 | Or equivalent |

QLS SERVICE PARTS INFORMATION

| NAVISTAR DEF HEAD UNIT PART NUMBERS | | | | |
|-------------------------------------|-------------------------------|-----------------------------|-----------------------------|-----------|
| 3% (QLS) / Gen 1 | 3% with Cover (QLS) / Gen 1.1 | 1% with Cover (QLS) / Gen 2 | 1% with Cover (QLS) / REMAN | TANK SIZE |
| 4097721C91 | 4254212C91 | 4163689C91 | 5012176R91 | 5 GAL |
| 4097722C91 | 4254211C91 | 4157846C91 | 5012171R91 | 7 GAL |
| 4097723C91 | 4254213C91 | 4163692c91 | 5012172R91 | 9.5 GAL |
| 4097724C91 | 4254214C91 | 4163693C91 | 5012173R91 | 12 GAL |
| 4097725C91 | 4254215C91 | 4163694C91 | 5012177R91 | 15 GAL |
| 4097727C91 (ProStar) | 4254216C91 | 4163695C91 | 5012174R91 | 15.5 GAL |
| | | | | 16 GAL |
| | | | | 23 GAL |

| | | | | |
|-----------------------------|--|--|--|------------------|
| 4097728C91 (LT) | 4254210C91 | 4140918C91 | 5012175R91 | 10.6GAL |
| | | | | 10.6GAL-LN |
| | | | | 15.9GAL |
| | | | | 15.9GAL-LN |
| | | | | 25.2GAL |
| 3% / Gen 1 (FLS) | 3% with Cover / Gen 1.1 (FLS) | 1% with Cover / Gen 2 (FLS) | 1% with cover / Reman (FLS) | TANK SIZE |
| 4099715C91 | 4254200C91 | 4163697C91 | 5012178R91 | 7 GAL |
| 4099716C91 | 4254201C91 | 4163698C91 | 5012179R91 | 9.5 GAL |
| 4099717C91 (ProStar) | 4254202C91 | 4163699C91 | 5012180R91 | 15.5 GAL |
| | | | | 16 GAL |
| | | | | 23 GAL |
| 4099718C91 (LT) | 4254203C91 | 4163700C91 | | 10.6GAL |
| | | | | 10.6GAL-LN |
| | | | | 15.9GAL |
| | | | | 15.9GAL-LN |
| | | | | 25.2GAL |

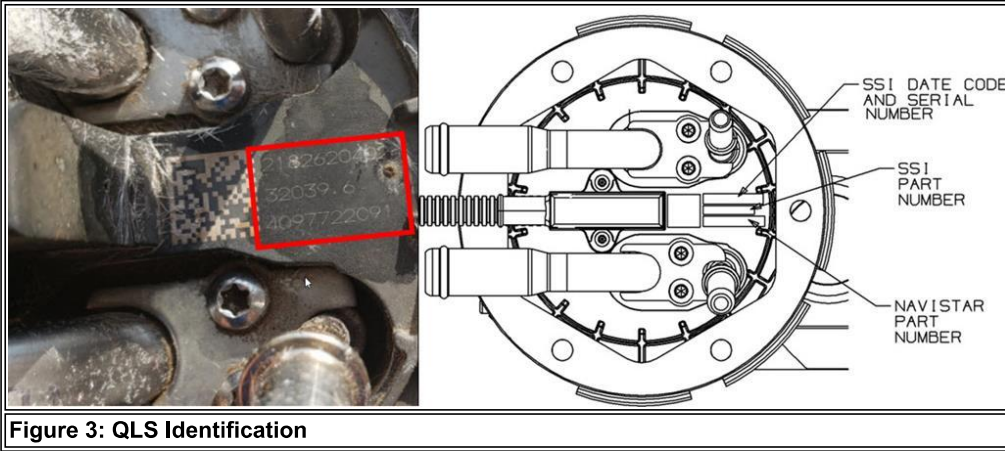

Figure 3: QLS Identification

DIAGNOSTIC STEP(S)

WARNING:

The EPA and CARB has only granted Navistar limited use of the QLS emergency calibration as it applies to the faults listed in the table above and diagnostic steps outlined in this article. The use of this calibration in any other circumstances could be considered tampering of an emission level component.

CAUTION:

This procedure is only intended to be used if a QLS is not available. If the QLS is available the part must be replaced and the calibration can NOT be installed.

| Step | Action | Decision |
|------|--|---|
| 1 | DIAGNOSTIC: Is the ESN marked with the TRP # T2489 on Cummins Quickserve? If the vehicle is not marked with the TRP then there is not a calibration available at this time. | Yes. Go to step 2 |
| | | No. The vehicle will not qualify for the TRP. Follow standard diagnostics. This letter does not apply |

| Step | Action | Decision |
|------|---|--|
| 2 | DIAGNOSTIC: Does the vehicle present with only QLS communication faults listed in the fault code section of this article? | Yes. Go to step 3 |
| | | No. The vehicle will not qualify for the |

TRP. Follow the diagnostics for the other fault codes present.

Note: Other aftertreatment components share the same aftertreatment datalink as the QLS, when other AFT components log communication fault codes with the QLS they are not a QLS

| Step | Action | Decision |
|------|---|--|
| 3 | <p>DIAGNOSTIC:</p> <p>Follow the circuit diagnosis in FCAP for the fault present. Note: The flow test of the DEFTHV should NOT be performed if the calibration is being installed.</p> <p>Did the circuit diagnostics indicate a replacement QLS is needed?</p> | <p>Yes: Leave the QLS disconnected and proceed to step 4</p> <p>No. The vehicle will not qualify for the TRP. Perform the necessary non QLS replacement repairs.</p> |

| Step | Action | Decision |
|------|--|--|
| 4 | <p>DIAGNOSTIC:</p> <p>Is there a replacement QLS available?</p> <p>Refer to the table above for QLS part numbers.</p> | <p>Yes. The vehicle will not qualify for the TRP. Please proceed with flow testing the DEFTHV and replacing the QLS.</p> <p>No. Refer to the repair steps listed below</p> |



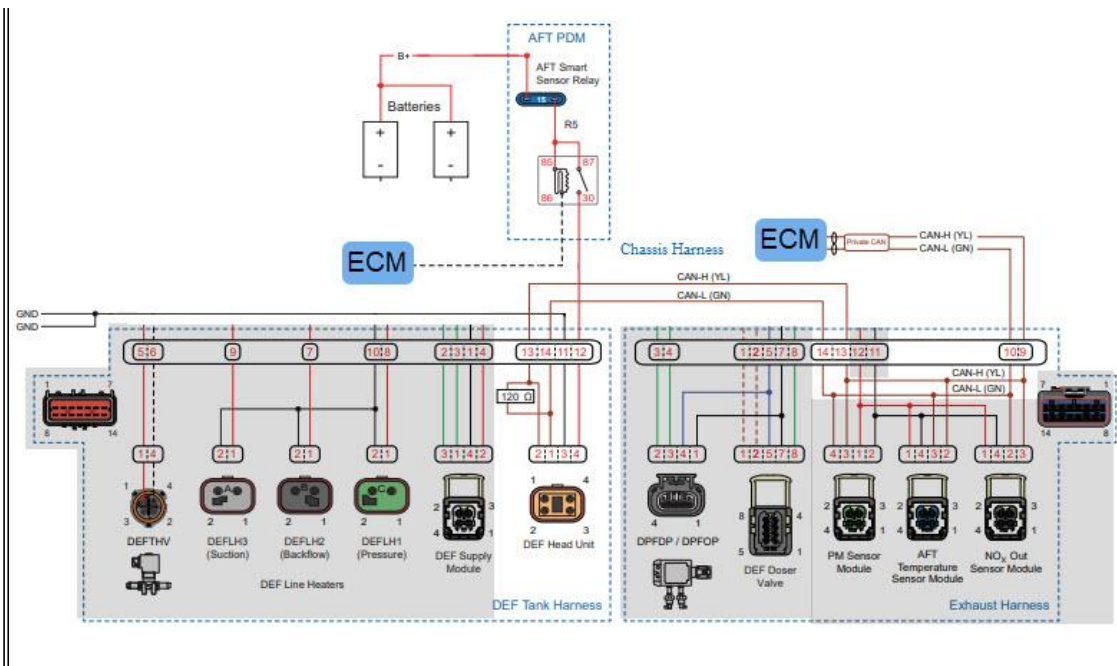

Figure 4: General QLS Wiring Diagram

Note: Refer to chassis circuit diagrams for detailed information

REPAIR STEP(s)

In some failure conditions the QLS sensor can produce faults intermittently, it is recommended that the sensor be removed electrically from the chassis harness to prevent this as it can lead to additional warnings and de-rate events. This can be performed simultaneously with the programming event. The intent of this procedure is to disconnect the sensor electrically and seal the harness to prevent moisture and corrosion in the chassis harness connector for when the QLS is replaced under future activity. The QLS must remain in the tank and connected to the DEF and coolant lines as they are still required for vehicle operation.

1. Ensure the QLS is disconnected from the chassis harness. **If the sensor is still connected it could result in shorting of the power circuit.**
2. Using wire cutters, cut the QLS pigtail harness as least four inches from the connector (Refer to figure #5). Once cut the pigtail can be moved to a bench for ease of installation.

Note: At no point is the QLS removed from the DEF tank during this procedure.

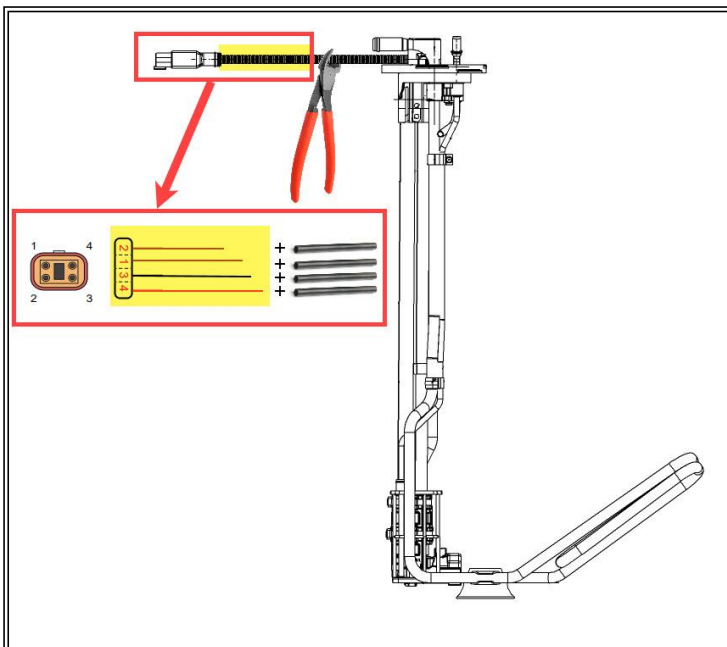

Figure 5: QLS Pigtail Modification

Item 1: QLS Pigtail

3. Refer to Cummins TRP# [T2489](#) and [TSB210187](#) and start the programming procedure on the vehicle
4. Remove the wire loom from the pigtail end.
5. Loop each wire and apply heat shrink tubing to each end of the wire (Refer to figure #6).

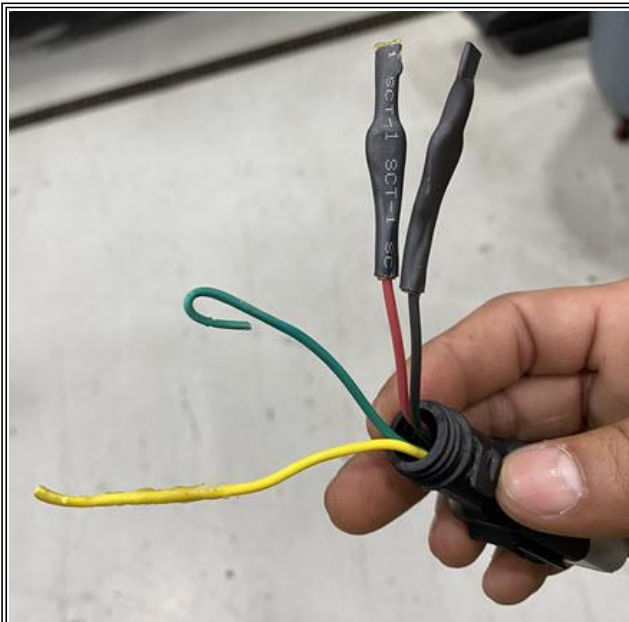

Figure 6: QLS Pigtail Wire Loop

6. Use a heat gun to apply heat to each piece of heat shrink tubing, ensuring glue is extruded from the end and sealed by pinching the end of each piece with pliers (Refer to figure #7).



Figure 7: QLS Pigtail Wire Sealing

7. Once all four wires are sealed, reconnect the pigtail to the chassis harness connector.
8. Secure the harness using a zip tie (Refer to figure #8).





Figure 8: QLS Pigtail Installed

- Item 1: Zip tie securing the harness
- Item 2: Pigtail connected to chassis connector
- Item 3: Harness to QLS left unsealed

9. Complete the vehicle programming as needed and disconnect the service tool and interface cable.

IMPORTANT:
 A customer letter should be provided to the driver and placed in each vehicle that receives the software. Ensure that the operator fully understand the impacts and effects of the DEF gauge prior to releasing the vehicle. Refer to Cummins TRP2489 for the required documentation.

DEF Cluster Alarm

Depending on the DLB parameter setting the cluster may produce an audible alarm for low DEF level. The default setting is set to "No Alarm", if the parameter has been changed it will need to be returned to the original setting of "No Alarm". Refer to the image below.

| Feature | Description | ... |
|---------|---|-------------------------------------|
| 0597082 | BCM PROG, DEF Gauge & Warning Indicator | <input checked="" type="checkbox"/> |
| 0597391 | BCM PROG, DEF TANK CAPACITY for 12 U.S. Gal. 45.4L Capacity | <input type="checkbox"/> |
| 0597368 | BCM PROG, DEF TANK CAPACITY for 15 U.S. Gal. 56.8L Capacity | <input type="checkbox"/> |
| 0597367 | BCM PROG, DEF TANK CAPACITY for 7 U.S. Gal. 26.5L Capacity | <input type="checkbox"/> |
| 0597366 | BCM PROG, DEF TANK CAPACITY for 5 U.S. Gal. 18.9L Capacity | <input type="checkbox"/> |
| 0597365 | BCM PROG, DEF TANK CAPACITY for 9.5 U.S. Gal. 35.9L Capacity | <input type="checkbox"/> |
| 0597238 | BCM PROG, DEF ECON & DIST TO E Cummins Engines | <input type="checkbox"/> |
| 0597237 | BCM PROG, DEF ECON & DIST TO E A26 Engines | <input type="checkbox"/> |
| 0597235 | BCM PROG, DEF TANK CAPACITY for 25.2 U.S. Gal. 95.3L Capacity | <input type="checkbox"/> |
| 0597234 | BCM PROG, DEF TANK CAPACITY for 15.9 U.S. Gal. 60.1L Capacity | <input type="checkbox"/> |

| ID | Parameter | Value | Unit | Description | Cfg. V... | Cfg. Unit |
|------|-------------------------|-------|---------|---|-----------|-----------|
| 2857 | DEF_Level_Min_WL | 10 | percent | Minimum set point for DEF level in-gauge warning light | 25 | perc... |
| 2858 | DEF_Level_Max_WL | 100 | percent | Maximum set point for DEF level in-gauge warning light | 250 | perc... |
| 2860 | DEF_Level_Filter_Param | 250 | No U... | DEF level gauge update rate.A value of 1 is the slowes... | 250 | No U... |
| 2859 | DEF_Level_Alrm_Ty_Param | 0 | No U... | | 0 | No U... |

| Description | Value |
|------------------------|-------|
| Continuous Single Tone | 1 |
| Five-short beeps | 4 |
| No Alarm | 0 |
| One-long beep | 2 |
| One-short beep | 3 |
| Repetitive short beeps | 7 |
| Ten-short beeps | 5 |
| Three-long beeps | 6 |

Figure 9: DLB Cluster Alarm Parameter Setting

Under the feature 597082 for "DEF Gauge & Warning Indicator" Ensure parameter ID 2859 for "DEF Level Alrm" is set to "0" or "No Alarm"

FREQUENTLY ASKED QUESTIONS (FAQ):

How do I get a Cummins fleet count?

- Phone: Dial 1-800-Cummins and choose option 1, followed by options 1 and 6 on our menu
- Email:
 - If in the US please use the following email address: fleetcountzapit@cummins.com
 - If in Canada please use the following email address: cec.tools@cummins.com (Eastern Canada) & cwceetools@cummins.com (Western Canada)

How do I perform the software update?

- Refer to [Cummins Insite Support Page](#).

Who pays for calibration, fleet count and diagnostic time?

- For Cummins powered vehicles, only if the QLS emergency calibration is installed, it will be filed and paid through the TRP# [T2489](#).

Can I replace the QLS after the calibration is installed?

- No, it will be replaced through a future action, Navistar and Cummins will provide documentation for this action at a later date. Until then the failed QLS should remain in the vehicle.

Can the sensor connector be left unplugged?

- No, the sensor connector cannot be left unplugged. Exposure to environmental conditions could induce other failures once the sensor is replaced at a later date. Please follow the repair procedure to cut and seal the sensor pigtail.

Can the calibration be used on faults other than the ones listed in this article?

- No, the calibration has only been approved for the fault listed in this article. If other faults are determined to be caused by a QLS failure the sensor will need to be replaced.

What if the QLS is causing a short on the aftertreatment datalink for V-Ref circuits while also setting communication faults?

- If the QLS is the cause, following the steps outlined under the repair section will remove the QLS electrically from the chassis harness correcting the short.

Do I need to replace the DEFTHV at the same time as installing the calibration?

- No, there is no need to flow test or replace the DEFTHV at this time. It will be handled in future actions when the QLS is replaced. If it is determined the DEFTHV is needed due to a tank not being able to thaw, it will need to be diagnosed and replaced under standard warranty.

How do I handle vehicles where my parts order is cancelled, however the failure does not qualify for the calibration?

- Place a new critical unit down order (with VIN) for the QLS and reference the old order in the case file.

If I had a QLS on order and already did initial diagnostics prior to the cal becoming available, do I need to do the diagnostics again before putting the cal in?

- No, we only need to ensure the circuit diagnostics have been performed prior to installing the calibration. If that has already been performed there is no need to repeat them.

I have a vehicle that the sensor was pulled out of to repair another vehicle, how do I handle this repair?

- A replacement sensor will need to be installed, the vehicle cannot operate without a QLS installed.

Is there a need to seal the wiring to the QLS?

- No, since the sensor has failed, it will be replaced at a later date. The wiring on the chassis side must be sealed.

WARRANTY INFORMATION

Warranty Claim Coding:

Refer to Cummins TRP # [T2489](#) and file the warranty claim with Cummins

Standard Repair Time(s):

Refer to Cummins TRP # [T2489](#) and file the warranty claim with Cummins

OTHER RESOURCES

[Master Service Information Site](#)

[Navistar Customer Reference Sheet 4328818R1](#)

[G-Letter G-19-100983 QLS Emergency Calibration](#)

[Cummins Quick Serve Online](#)

[TRP # T2489 ECM Calibration for DEF Header Sensor Failures due to Parts Shortage TRP for Navistar Vehicles](#)

[TSB210187 - Fault Codes 3868, 4572 and 4677 Caused by Diesel Exhaust Fluid \(DEF\) Header Malfunction](#)

 Hide Details

Feedback Information

Viewed: 3408
Helpful: 19
Not Helpful: 0

| Staff ID | Client ID | Comments | Created Date |
|----------|-----------|--|----------------------|
| | DYYCMH4 | You received the following feedback From: DYYCMH4 - Christine Horst Email Address: horstc@rushenterprises.com Job Classification: AD006, Warranty Manager Dealer: RUSH TRK CTR OF IL Feedback: Will Cummins update TRP2489 to allow additional time to cut the pigtail per the new update? | 9/30/2021 1:07:35 PM |