

2022 Sequoia Pre-Delivery Service (PDS)

Service Category General

Section Pre-Delivery Service

Market USA

Toyota Supports
 ASE Certification 

Applicability

YEAR(S)	MODEL(S)	ADDITIONAL INFORMATION
2022	Sequoia	

Introduction

Pre-Delivery Service (PDS) is a critical step in satisfying our new car customers. Customer feedback indicates the following areas deserve special attention when performing PDS:

- Careful inspection for paint chips/scratches and body dents/dings.
- Proper operation of electrical accessories (including interior light, clock, and radio reset).
- Interior cleanliness.
- Proper function of mechanical systems.

Customer retention and proper maintenance of vehicles are and have always been a major focus for Toyota. To help remind customers that regular service is essential to the proper maintenance of the vehicle, dealers are required to install a service reminder sticker before delivery. By doing this, customers will be reminded to return to your dealership for service. Your current service reminder sticker may be used. (See PDS Check Sheet item 8 of “Final Inspection and Cleaning.”)

This bulletin contains the PDS procedures that apply specifically to 2022 model year Sequoia vehicles. A universal PDS [Check Sheet](#) that contains PDS steps that apply to all 2022 model year Toyota vehicles has been developed. To properly perform a complete PDS, you must complete all procedures contained in this TSB as well as the universal PDS [Check Sheet](#).

In addition, if the vehicle is stored for over 30 days, be sure to follow [Long-Term Vehicle Storage Guidelines](#).

2022 Sequoia Pre-Delivery Service (PDS)

Warranty Policy

If the need for additional repairs or adjustment is noted during PDS, the required service should be performed under warranty. Reimbursement will be managed under the warranty policy.

The Warranty Policy and Procedures Manual requires that you maintain the completed Check Sheet in the customer's file. If you cannot produce a completed form for each retailed vehicle upon TMS and/or Region/Distributor audit, the PDS payment amount will be subject to debit.

An additional Repair Order completed in conjunction with normal PDS MUST have time punch/flags for service. If multiple repairs are performed, separate time flags MUST be punched for each repair.

Warranty Information

OP CODE	DESCRIPTION	TIME	OFF	T1	T2
001013	Pre-Delivery Service (PDS)	1.0	–	–	–

Required Tools & Equipment

REQUIRED EQUIPMENT	SUPPLIER	PART NUMBER	QTY
Techstream ADVi*	ADE	TSADVUNIT	1
Techstream 2.0		TS2UNIT	
Techstream Lite		TSLITEPDLR01	
Techstream Lite (Green Cable)		TSLP2DLR01	

*Essential SST.

NOTE

- Only ONE of the Techstream units listed above is required.
- Software version 16.10.017 or later is required.
- Additional Techstream units may be ordered by calling Approved Dealer Equipment (ADE) at 1-800-368-6787.

2022 Sequoia Pre-Delivery Service (PDS)

Procedures

- [Short Pin Installation](#) 3
- [Compass Calibration*](#) 4
- [Tire Pressure Warning System \(TPWS\) Initialization](#) 4
- [Front License Plate and Mounting Bracket Installation*](#) 5
- [Dealer Contact Information for Call Dealer Head Unit Function*](#) 6
- [Entune™ 3.0 App Suite Connect Initialization/Update*](#) 6

*If applicable.

Short Pin Installation

The short pin has been removed at the assembly plant to reduce parasitic current draw in transit and storage. The removed short pin is stored in the blank space of the relay block in the engine compartment. The short pin **MUST** be reinstalled to the original location during PDS.

Figure 1.

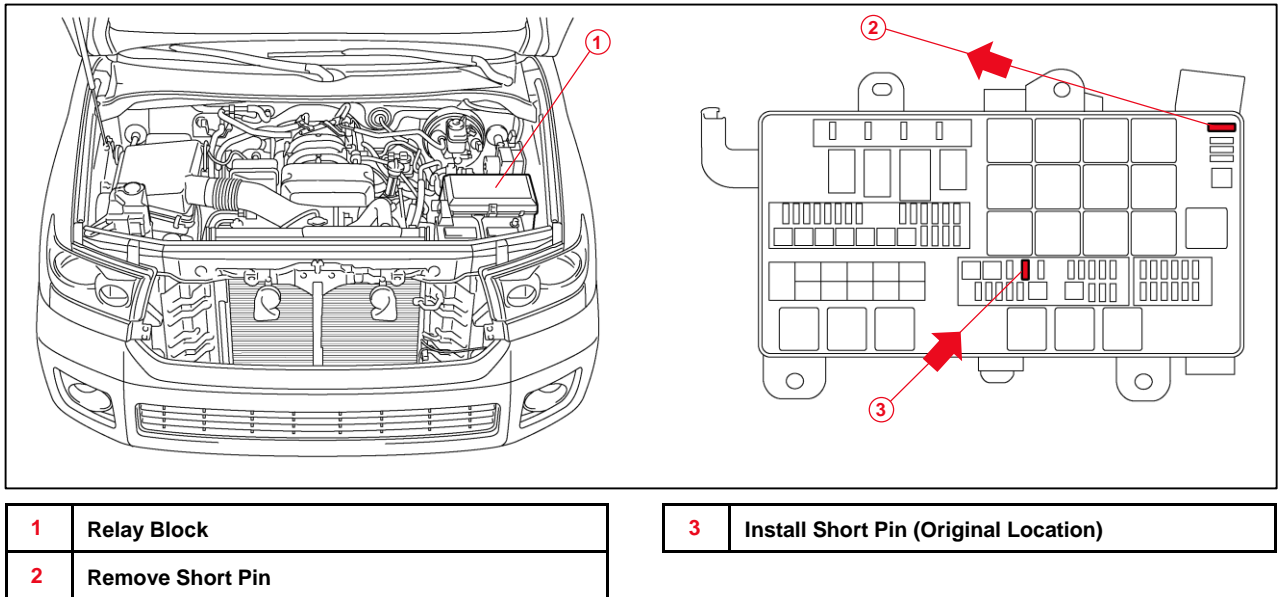

2022 Sequoia Pre-Delivery Service (PDS)

Compass Calibration

Refer to the applicable Repair Manual for the [calibration procedure](#) for vehicles equipped with a compass in the Multi-information Display.

NOTE

- Do NOT perform calibration of the compass in a place where the earth's magnetic field is subject to interference (underground parking, under a steel tower, between buildings, roof parking, near a railroad crossing, near a large vehicle, etc.).
- Do NOT operate electric systems during the calibration (moonroof, power windows, etc.), as they may interfere with the calibration.
- The dot on the compass display disappears when calibration has been completed.

Tire Pressure Warning System (TPWS) Initialization

Refer to the applicable Repair Manual for the TPWS [initialization procedure](#).
Note the spare tire does NOT have a TPWS sensor.

NOTE

To adjust the tire pressure correctly when the outside temperature is significantly colder than shop temperature, perform a Health Check using Techstream and select the compensation tire pressure checkbox. Compensation pressures will display on the Health Check results screen. Adjust the tire pressure when the tires are cold.

2022 Sequoia Pre-Delivery Service (PDS)

Front License Plate and Mounting Bracket Installation

The front license plate bracket and two self-tapping screws are loaded in the vehicle at the assembly plant. Follow this procedure to install the front license plate bracket and front license plate in states where it is required by law.

1. Using a size 5/32 drill bit, drill holes into the dimple marks on the front bumper.
2. Attach the front license plate mounting bracket hooks to the air intake section of the front bumper.

NOTE

The license plate bracket overlaps the radar sensor cover approximately 1.75 in. (45 mm).

3. Align the holes in the front license plate mounting bracket with the drilled holes on the front bumper.
4. Install two screws (screw A in Figure 2) through the bracket securing the front license plate mounting bracket to the front bumper.
5. Install two self-tapping screws through the license plate holes extending into the bracket.

NOTICE

Do not install any items that extend above the license plate bracket.

Figure 2.

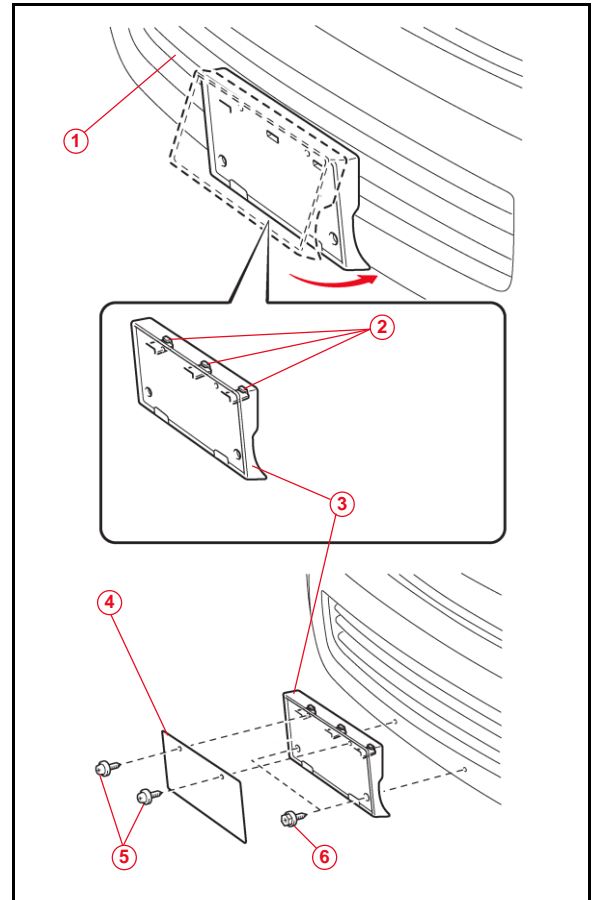

1	Air Intake
2	Hooks
3	Front License Plate Mounting Bracket
4	License Plate
5	Self-tapping Screw
6	Screw A

2022 Sequoia Pre-Delivery Service (PDS)

Dealer Contact Information for Call Dealer Head Unit Function

Refer to the *Multimedia System Owner's Manual* to [add dealer contact information](#).

Entune™ 3.0 App Suite Connect Initialization/Update

Refer to [T-SB-0037-21](#) *Entune™ 3.0 App Suite Connect* to initialize/update the Entune™ 3.0 App Suite Connect head unit.