

# TECHNICAL INSTRUCTIONS

FOR

SPECIAL SERVICE CAMPAIGN 21LC01

LOW-PRESSURE FUEL PUMP

CERTAIN 2017 – 2020 RX 450h VEHICLES  
CERTAIN 2018 – 2020 RX 450hL VEHICLES  
CERTAIN 2019 ES300h VEHICLES  
CERTAIN 2013 – 2015 LS 600h VEHICLES  
CERTAIN 2014 – 2015 & 2018 GS 450h VEHICLES

The repair quality of covered vehicles is extremely important to Toyota. All dealership technicians performing this special service campaign are required to successfully complete the most current version of the E-Learning course “Safety Recall and Service Campaign Essentials”. To ensure that all vehicles have the repair performed correctly; technicians performing this repair are required to currently have completed all of the following courses:

-L623 Electrical Circuit Diagnosis

It is the dealership’s responsibility to select technicians that have completed the above courses to perform this repair. Carefully review your resources, the technician skill level, and ability before assigning technicians to this repair. It is important to consider technician days off and vacation schedules to ensure there are properly trained technicians available to perform this repair at all times.

# I. OPERATION FLOW CHART

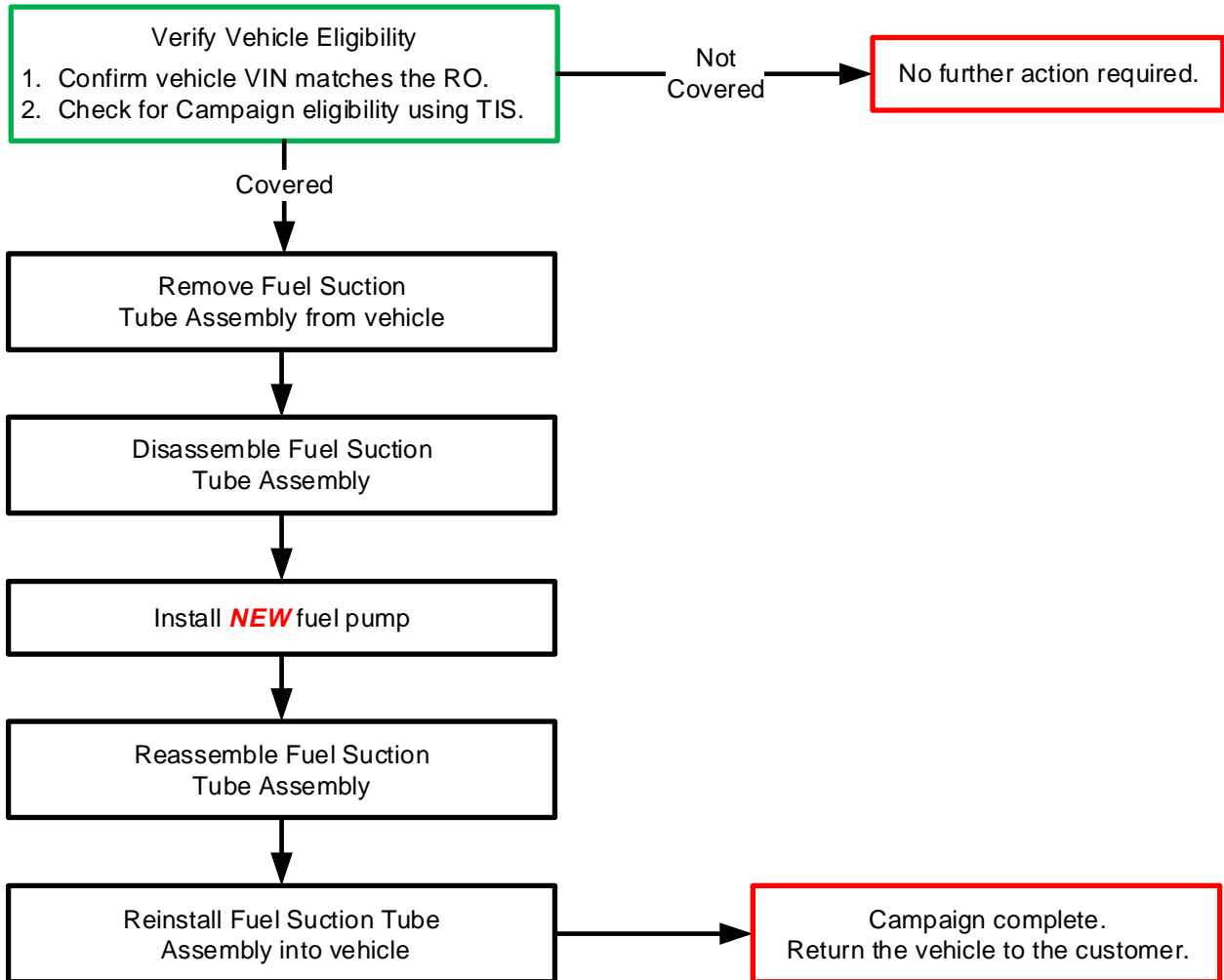

## II. IDENTIFICATION OF AFFECTED VEHICLES

### 1. CHECK VEHICLE FOR CAMPAIGN ELIGIBILITY

- Compare the vehicle's VIN to the VIN listed on the Repair Order to ensure they match.
- Check the TIS Vehicle Inquiry System to confirm the VIN is involved in this Campaign, and that it has not already been completed.

**Note:** TMNA warranty will not reimburse dealers for repairs completed on vehicles that are not affected or were previously completed, even by another dealer.

## III. PREPARATION

### A. PARTS

Model	Part #	Qty	Description
RX 450h / RX 450hL	04009-86531	1	KIT, PUMP, FUEL
	04009-81433	1	REPLACEMENT KIT, FUEL PUMP
ES 300h (VIN begins with JTH)	04009-86325	1	KIT, PUMP, FUEL
	04009-80747	1	REPLACEMENT KIT, FUEL PUMP
ES 300h (VIN begins with 58A)	04009-86325	1	KIT, PUMP, FUEL
	04009-80747	1	REPLACEMENT KIT, FUEL PUMP
	04009-95106	2	HOOK, REAR SEAT CUSHION LOCK SSP KIT
LS 600h	04009-86138	1	KIT, PUMP, FUEL
	04009-80153	1	REPLACEMENT KIT, FUEL PUMP
GS 450h	04009-86138	1	KIT, PUMP, FUEL
	04009-80747	1	REPLACEMENT KIT, FUEL PUMP

Warranty will only reimburse dealers for the part numbers listed. Any other part numbers will not be accepted on the campaign claim.

### B. TOOLS & EQUIPMENT

- Standard Hand Tools
- Torque Wrench
- Air Blow Gun
- Gas Caddy (minimum 25-gallon capacity)

### C. MATERIALS

- Brake Cleaner

## D. CAMPAIGN TOOLS

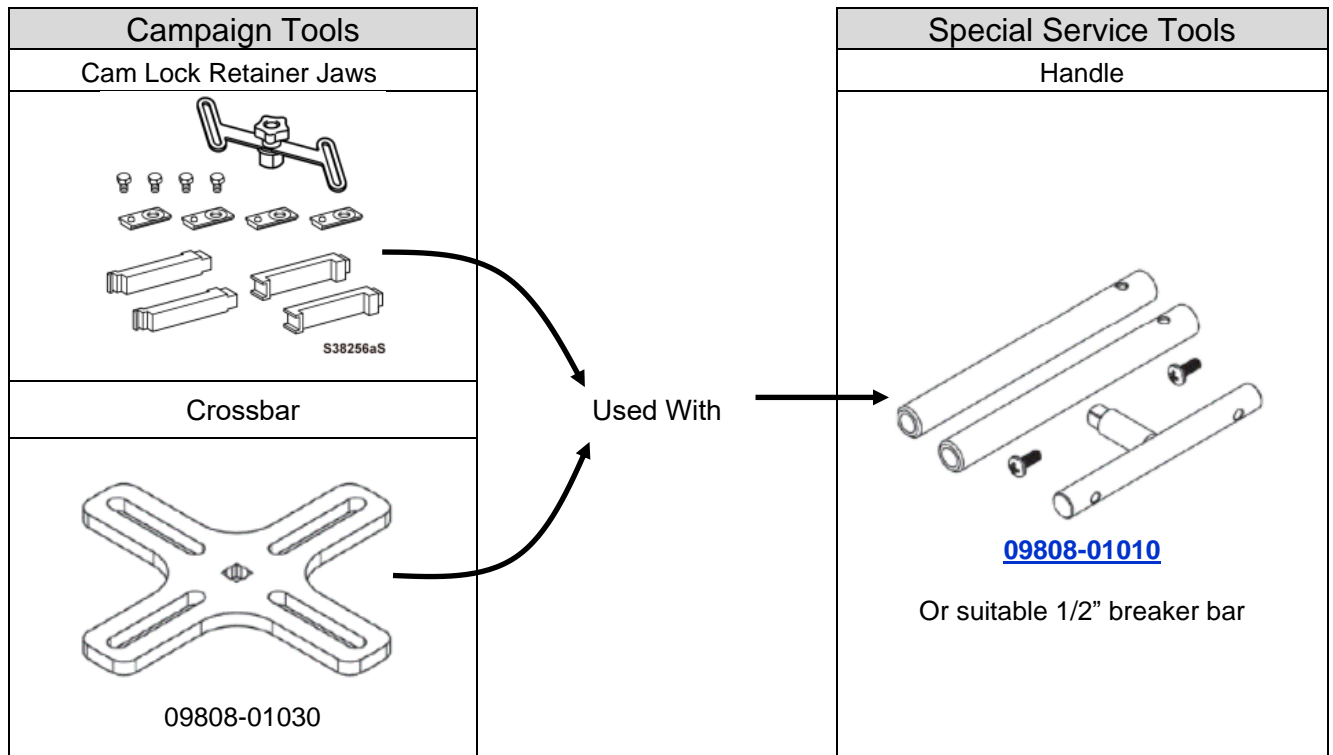

Each dealership was provided with a Crossbar and a set of Cam Lock Retainer Jaws for removing the Cam Lock type retainer rings when Safety Recall 20LA01 was announced. These same jaws and crossbar will be used for the GS 450h and ES 300h vehicles involved in this Special Service Campaign 21LC01.

The jaws and crossbar should be used with the dealership's existing handle set from the Fuel Sender Lock Nut Wrench Set (09808-14031). A 1/2" breaker bar can also be used. This set of tools will supplement the SST kit that each dealership currently has. Additional SST's can be purchased through the [Lexus Special Service Tools \(SST\)](#) website.



## E. SPECIAL SERVICE TOOLS

In the affected models, there are two different types of Fuel Pump Retainer Rings. Reference the following chart to determine the proper tool for removal.

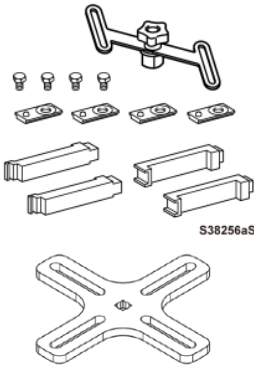
	RETAINER TYPE	
Models	ES 300h GS 450h	RX 450h RX 450hL LS 600h
Type:	<b><u>Cam Lock</u></b> 	<b><u>Bolt In</u></b> 
<b>Option 1</b> SST	<p><b><u>SST</u></b></p>  <p>Sender Lock Nut Wrench Kit (<a href="#">09808-14031</a>) Claw: 105mm Jaw Set (<a href="#">09808-01070</a>) Crossbar (<a href="#">09808-01030</a>)</p>	No SST Required
<b>Option 2</b> Campaign Tool (improved design over SST)	<p><b><u>Campaign Tool:</u></b> Cam Lock Retainer Jaws</p>  <p>Requires use of the Handle from the Fuel Sender Lock Nut Wrench Kit, or a 1/2" breaker bar.</p>	No campaign tool required

## IV. BACKGROUND

The subject vehicles are equipped with a low-pressure fuel pump which may stop operating. If this were to occur, warning lights and messages may be displayed on the instrument panel, and the engine may run rough. This will lead to the vehicle entering a failsafe driving mode in which the vehicle can still be driven for certain distances.

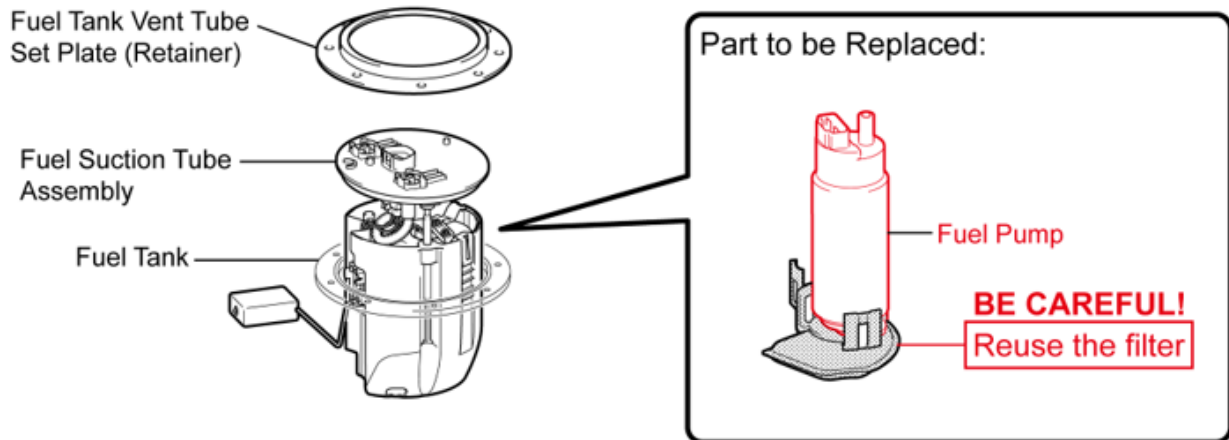

\*The configuration of the parts will differ depending on the specification.

S38182aSU

## V. SAFETY PRECAUTIONS

### CAUTION:

- When installing/uninstalling the fuel system components, keep safety first in mind and carefully observe the following instructions to avoid accidents:
  - a. When working on the fuel system, display a Flammable - Keep Fire Away sign.
  - b. Smoking is prohibited nearby.
  - c. Perform this work in an area where there are no sparks nearby from the operation of welders, grinders, drills, electric motors, stoves, etc.
  - d. **DO NOT** use electrical devices nearby because they can become hot and the operation of power switches can generate sparks.
  - e. **DO NOT** use iron or steel hammers while working, because they may generate sparks.
  - f. **DO NOT** start engines even in adjacent stalls.
  - g. Prepare fire extinguishers before starting any work.
  - h. Perform this work in a well-ventilated area (natural ventilation). **DO NOT** use exhaust fans or electric fans, because their motors might generate sparks.
  - i. Since it is possible for fuel vapor to build up, **DO NOT** work in or near a pit.
  - j. If fuel is spilled, use shop towels or similar material to quickly wipe it up and then use compressed air to diffuse the fuel vapor.
  - k. Shop towels and other materials that have come into contact with fuel should be dried in a well-ventilated area and then disposed of as appropriate.

## VI. COMPONENTS

RX 450h / RX 450hL

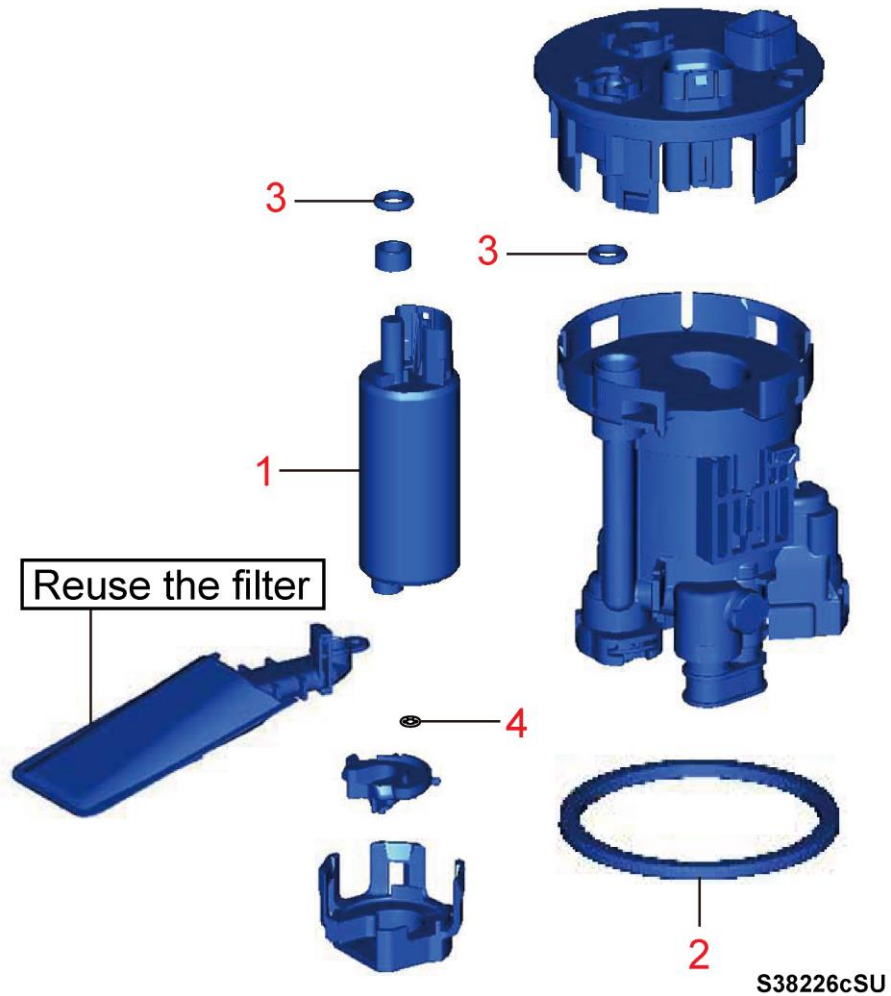

Replacement items in red

No.	Part #	Qty	Contents of Part Kit	Qty	Tape Color
1	04009-86531	1	FUEL PUMP	1	
2			FUEL SUCTION TUBE GASKET	1	
3	04009-81433	1	O-RING	2	GOLD
4			CLIP (for fuel pump filter)	1	WHITE

Warranty will only reimburse dealers for the part numbers listed. Any other part numbers will not be accepted on the campaign claim.

ES 300h  
(VIN begins with JTH)

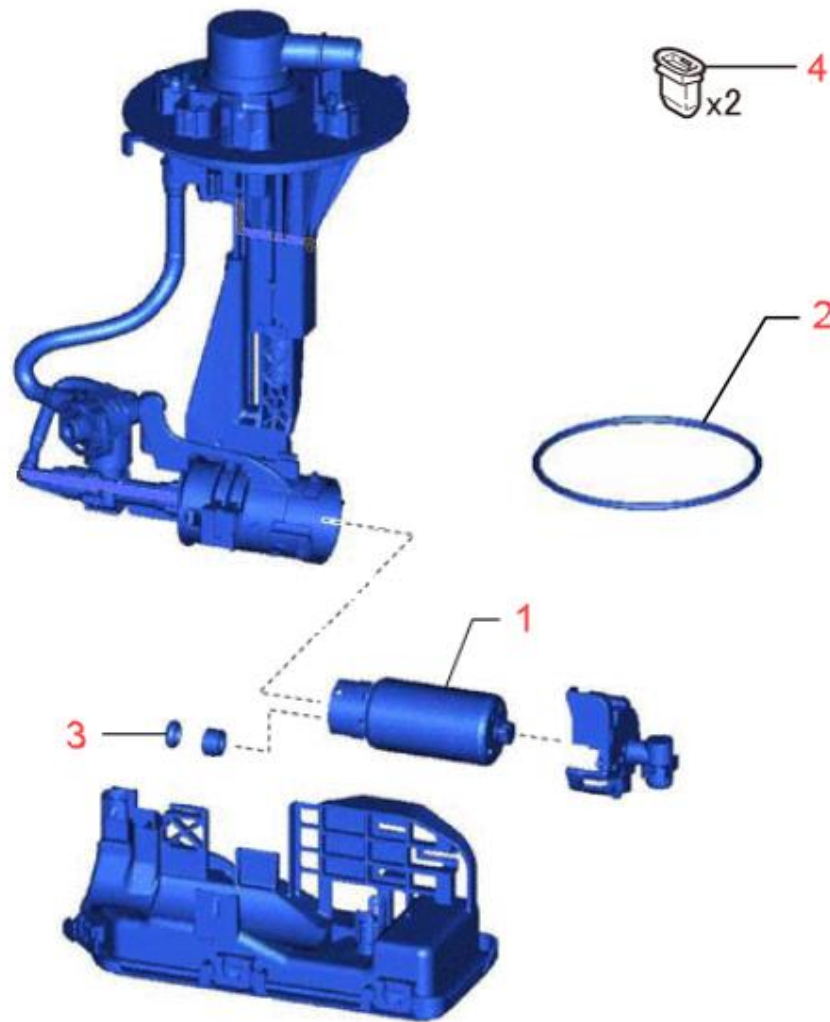

**Replacement items in red**

No.	Part #	Qty	Contents of Part Kit	Qty	Tape Color	Remarks
1	04009-86325	1	FUEL PUMP	1		
2	04009-80747	1	FUEL SUCTION TUBE SET GASKET	1		
3			O-RING	2	GOLD	Dispose of <u>1</u> o-ring
4			REAR SEAT CUSHION LOCK HOOK	2		
5			O-RING	1	RED	Dispose (Not used)
6			O-RING	1	GREEN	Dispose (Not used)
7			FUEL TANK PIPE SETTING HOLDER	1	WHITE	Dispose (Not used)

Warranty will only reimburse dealers for the part numbers listed. Any other part numbers will not be accepted on the campaign claim.

**DISPOSE OF FOLLOWING PARTS FROM PARTS KIT**

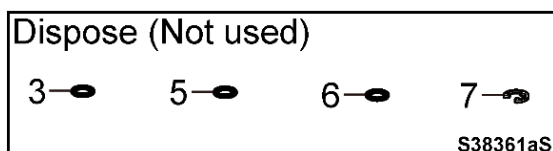



ES 300h  
(VIN begins with 58A)

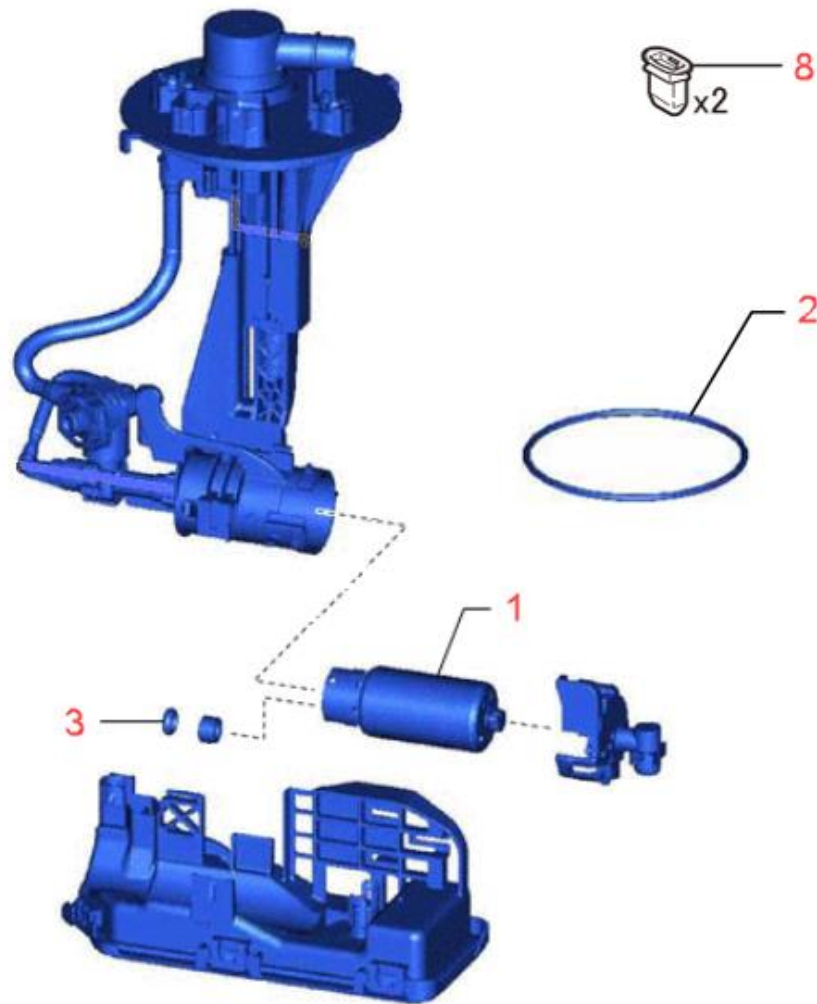

Replacement items in red

No.	Part #	Qty	Contents of Part Kit	Qty	Tape Color	Remarks
1	04009-86325	1	FUEL PUMP	1		
2	04009-80747	1	FUEL SUCTION TUBE SET GASKET	1		
3			O-RING	2	GOLD	Dispose of 1 o-ring
4			REAR SEAT CUSHION LOCK HOOK	2		Dispose (Not used)
5			O-RING	1	RED	Dispose (Not used)
6			O-RING	1	GREEN	Dispose (Not used)
7			FUEL TANK PIPE SETTING HOLDER	1	WHITE	Dispose (Not used)
8			04009-95106	2	REAR SEAT CUSHION LOCK HOOK	2

Warranty will only reimburse dealers for the part numbers listed. Any other part numbers will not be accepted on the campaign claim.

**DISPOSE OF FOLLOWING PARTS FROM PARTS KIT**

Dispose (Not used)



# LS 600h

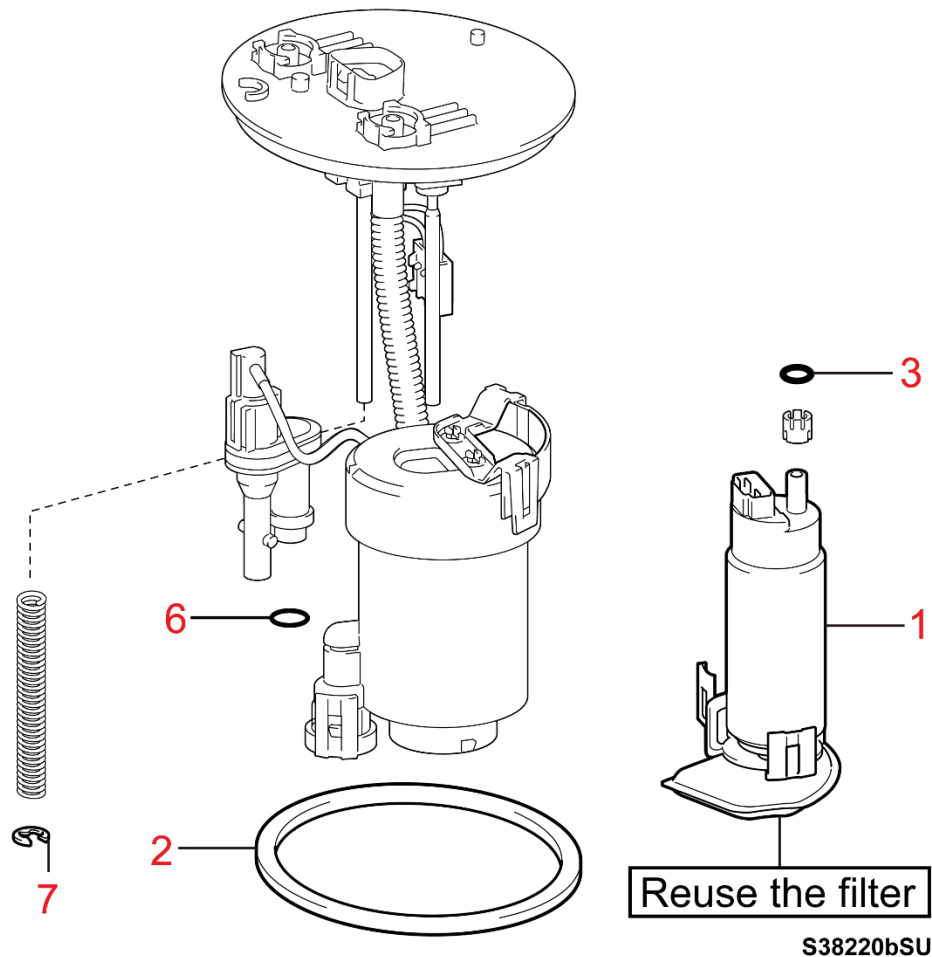

Replacement items in red

No.	Part #	Qty	Contents of Part Kit	Qty	Tape Color	Remarks
1	04009-86138	1	FUEL PUMP	1		
2	04009-80153	1	FUEL SUCTION TUBE SET GASKET	1		
3			O-RING	2	GOLD	Dispose of <u>1</u> o-ring
4			REAR SEAT CUSHION LOCK HOOK	4		Dispose (Not used)
5			O-RING	1	RED	Dispose (Not used)
6			O-RING	1	GREEN	
7			FUEL TANK PIPE SETTING HOLDER	1	WHITE	

Warranty will only reimburse dealers for the part numbers listed. Any other part numbers will not be accepted on the campaign claim.

## DISPOSE OF FOLLOWING PARTS FROM PARTS KIT

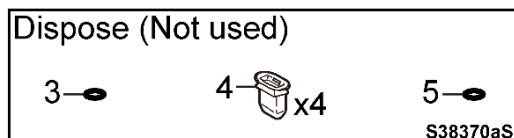

GS 450h

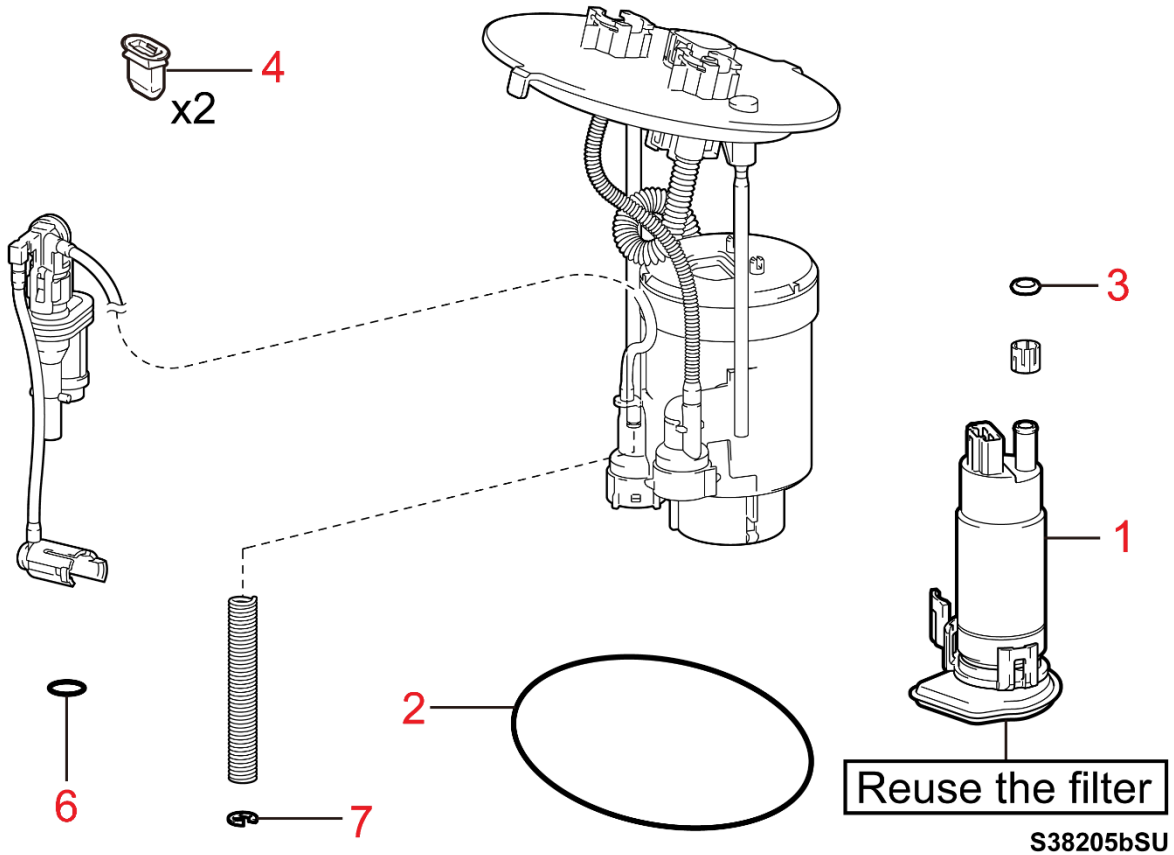

Replacement items in red

No.	Part #	Qty	Contents of Part Kit	Qty	Tape Color	Remarks
1	04009-86138	1	FUEL PUMP	1		
2	04009-80747	1	FUEL SUCTION TUBE SET GASKET	1		
3			O-RING	2	GOLD	Dispose of 1 o-ring
4			REAR SEAT CUSHION LOCK HOOK	2		
5			O-RING	1	RED	Dispose (Not used)
6			O-RING	1	GREEN	
7			FUEL TANK PIPE SETTING HOLDER	1	WHITE	

Warranty will only reimburse dealers for the part numbers listed. Any other part numbers will not be accepted on the campaign claim.

**DISPOSE OF FOLLOWING PARTS FROM PARTS KIT**

Dispose (Not used)

3 — 5 — S38362aS

## VII. REMOVE FUEL SUCTION TUBE ASSEMBLY



**Use TIS to confirm that this vehicle is eligible for the campaign before proceeding (p. 3). Warranty will not pay claims on ineligible vehicles.**



### 1. CHECK FOR DTC'S

- a. Using a Techstream, perform a Health Check to check for Diagnostic Trouble Codes.

**Note:** *This Special Service Campaign covers only the replacement of the fuel pump and associated parts. It does not cover the diagnosis or replacement of any other parts on the vehicle.*

### REMOVAL TIP: FUEL LEVEL

If the fuel level inside the fuel tank is above the specified level, fuel may overflow from the fuel tank during the removal of the fuel suction tube assembly. Confirm the fuel level in the vehicle is below the specified level before proceeding. If necessary, drain fuel from the tank. Note that the customer owner letter for this campaign will recommend for the customer to arrive with the specified fuel level or less to reduce the amount of time needed by the technician to drain fuel. However, this is not a requirement for the customer. Refer to the Dealer Letter for a sample of the owner letter.

Model	FUEL LEVEL RECOMMENDATIONS	
	Slightly below the F line on the fuel level gauge	1/3 or less
RX 450h RX 450hL	✓	
ES 300h GS 450h LS 600h		✓

**Note:** If fuel needs to be removed from the tank, be sure to recover it into an approved fuel recovery system. Suitable systems are available from the [Lexus Approved Dealer Equipment](#) website.

## REMOVAL TIP: CAM LOCK STYLE RETAINER

A set of Cam Lock Claws and Support Columns was previously supplied to each dealership for use with Safety Recall 20LA01 in May 2020. The configuration of the retainer engagement sections of those claws is an improved design over the SST version that is referenced in the TIS repair manual. These **NEW** claws that were shipped for 20LA01 are an improved design that enables a firm attachment to the retainer. In addition to the claws, 2 support columns were provided which will support the retainer more securely during installation and removal. Be sure to assemble and use the tools using the following procedures.

### Campaign Tool Cam Lock Set:

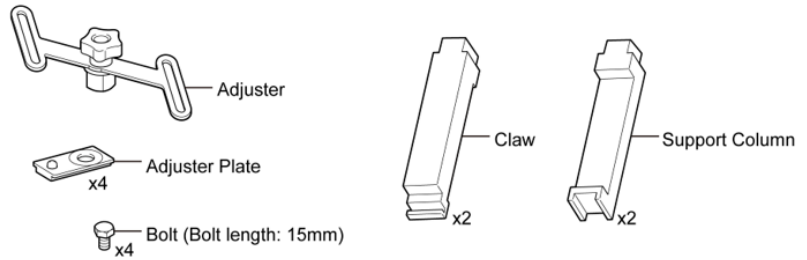

S38197aSU

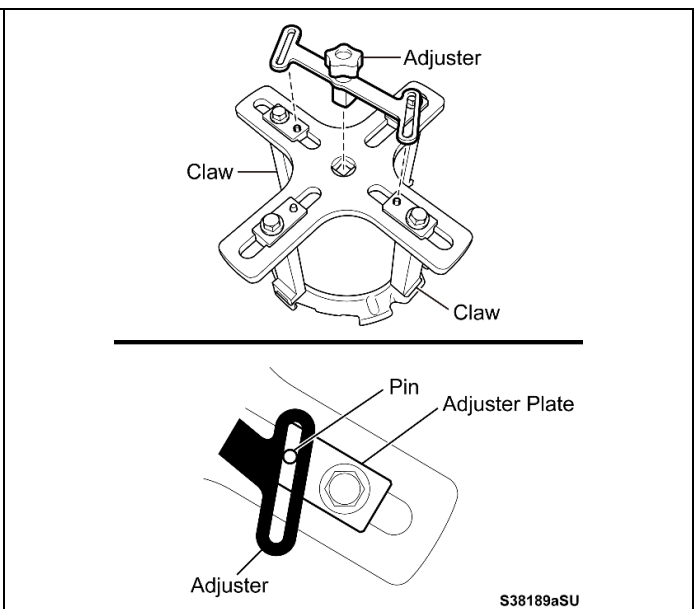
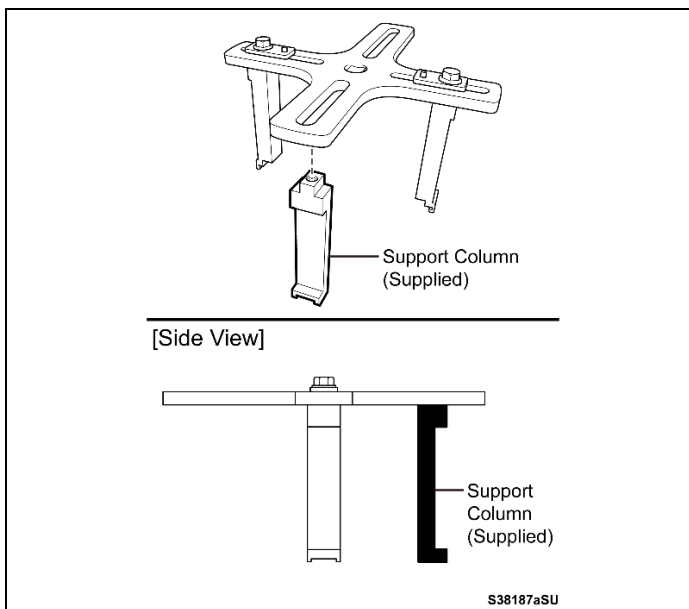
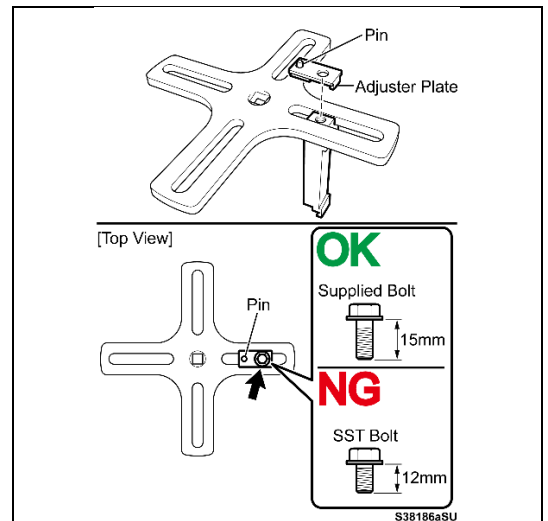
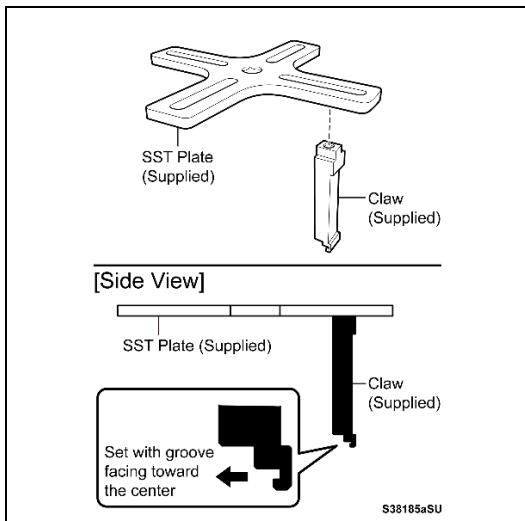

# REMOVAL TIP: CAM LOCK STYLE RETAINER (cont.)

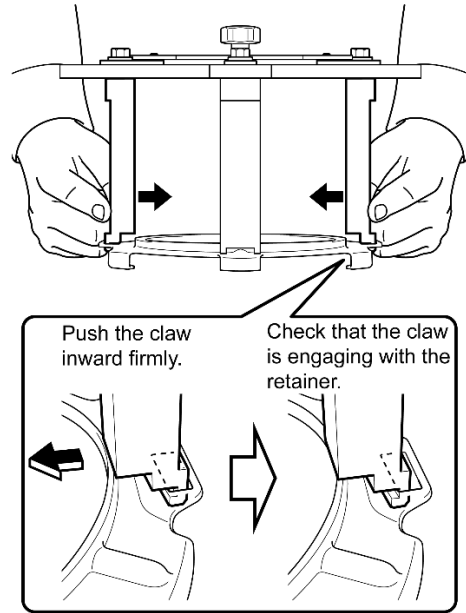
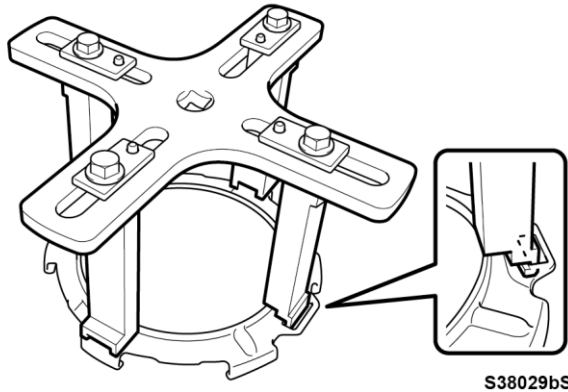

**OK**

**NG**

**NG**

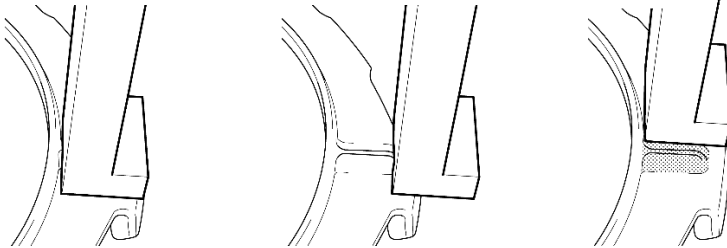

Lightly tighten the adjuster

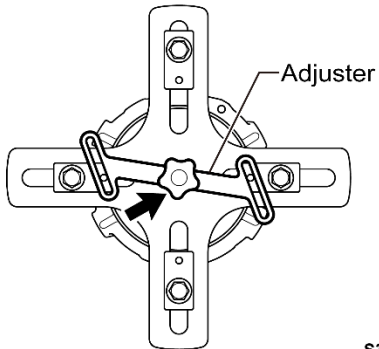

Fully tighten the 4 bolts

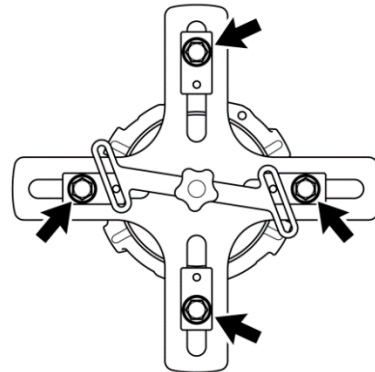

## REMOVAL PROCEDURE: RX 450h/450hL FUEL TANK

**FUEL TANK REMOVAL (RX 450h/450hL Only):** The parts in the illustration below are **not** necessary to be removed when the fuel tank is removed and re-installed.

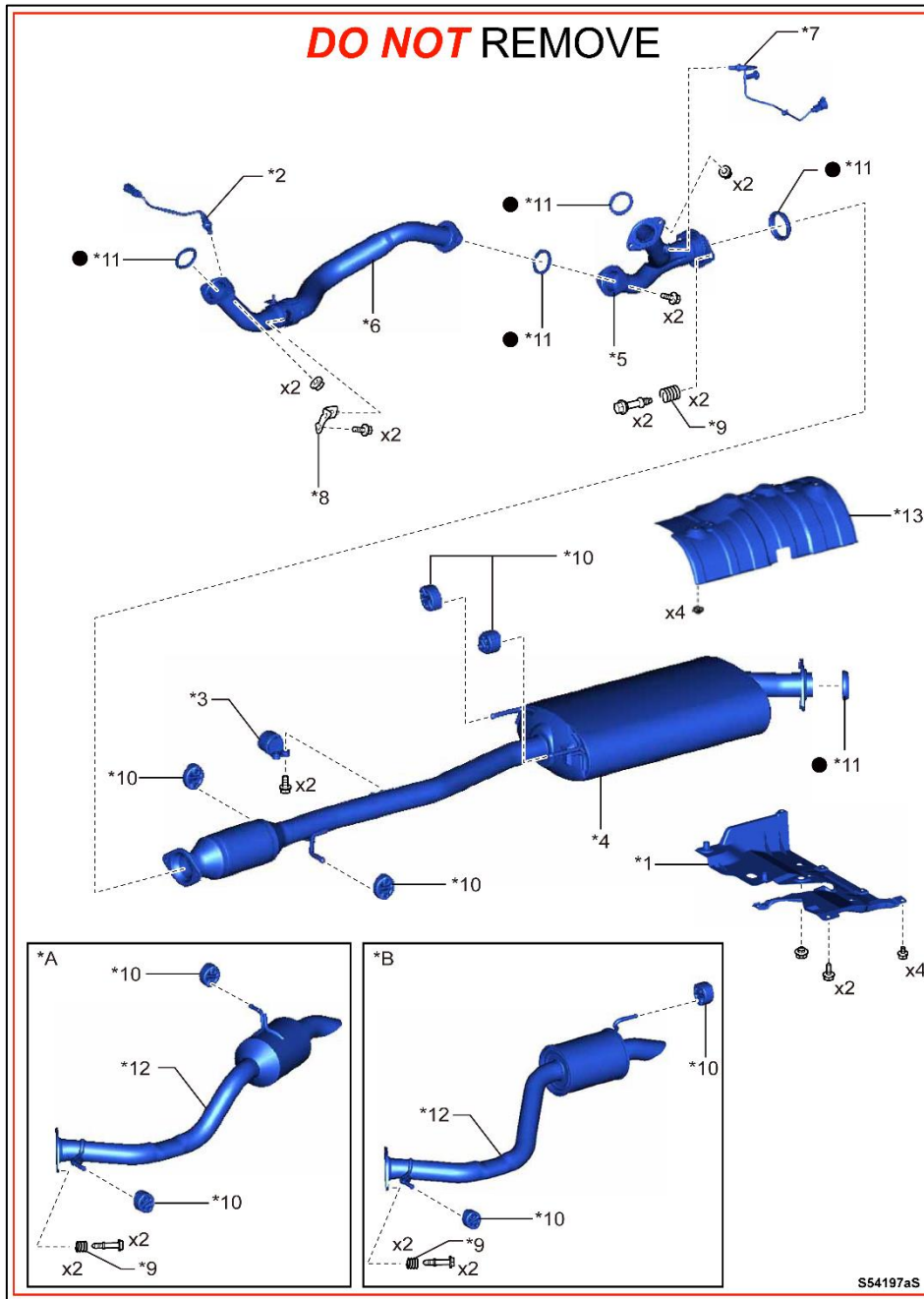

*A	w/o Rear No. 2 Seat	*B	w/ Rear No. 2 Seat
*1	FRONT FLOOR COVER LH	*2	HEATED OXYGEN SENSOR (for Bank 1)
*3	EXHAUST PIPE DAMPER	*4	CENTER EXHAUST PIPE ASSEMBLY (TWC: Rear Catalyst)
*5	FRONT NO. 3 EXHAUST PIPE SUB-ASSEMBLY	*6	FRONT EXHAUST PIPE ASSEMBLY
*7	HEATED OXYGEN SENSOR (for Bank 2)	*8	EXHAUST PIPE SUPPORT BRACKET
*9	COMPRESSION SPRING	*10	EXHAUST PIPE SUPPORT
*11	EXHAUST PIPE GASKET	*12	TAIL EXHAUST PIPE ASSEMBLY
*13	NO. 3 FRONT FLOOR HEAT INSULATOR	●	Non-reusable part

## REMOVAL PROCEDURE: RX 450h/450hL FUEL TANK (cont.)

### FUEL TANK REMOVAL (RX 450h/450hL Only):

- **2018 – 2020 MY:** It is not necessary to complete steps #19 - #25 of the fuel tank removal repair manual procedure on TIS.
- **2017 MY:** It is not necessary to complete steps #17 - #23 of the fuel tank removal repair manual procedure on TIS.

### REMOVAL TIP: TUBE ASSY REMOVAL

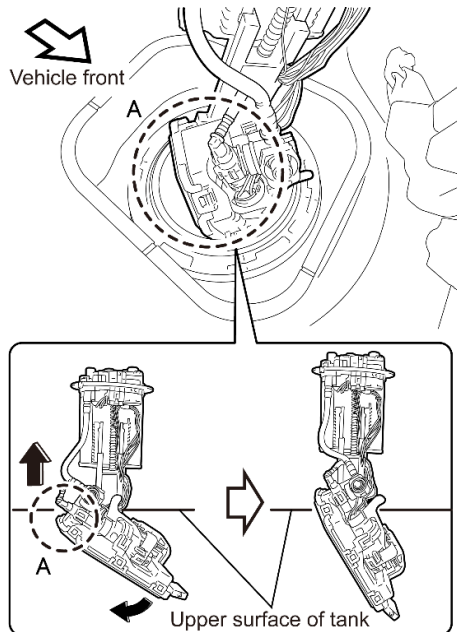

Illustration shows an image, and the shape of parts may differ with that of actual ones. S70006as

- 1) Slightly raise the fuel suction tube assembly during this operation to make sure that the sender gauge does not interfere with the inside of tank.
- 2) Pull up the fuel suction tube assembly to the position indicated in the illustration. Pull portion (A) by hand to swing the lower part of fuel suction tube assembly downward, and then remove the fuel suction tube assembly from the tank.



- **DO NOT** bend the arm of fuel sender gauge assembly.
- **DO NOT** damage the wire harness at edges of service hole when removing the fuel suction tube assembly.



## REMOVAL TIP: FUEL LEVEL SENDER

When removing and reinstalling the Fuel Level Sender from the fuel tank, take extra care with the arm of the fuel sender. It can be easily bent. Additionally, do not touch the electric circuit of the sender assembly.

Do not touch the electric circuit of the fuel sender gauge.

Do not deform the arm of the fuel sender gauge.



### 2. REMOVE FUEL SUCTION TUBE ASSEMBLY FROM VEHICLE

- a. Click the link below to access the repair manual instructions on TIS for removing the fuel suction tube assembly from the vehicle.

<b>REMOVAL</b>				
RX 450h	<a href="#">2017</a>	<a href="#">2018</a>	<a href="#">2019</a>	<a href="#">2020</a>
RX 450hL	<a href="#">2018</a>	<a href="#">2019</a>	<a href="#">2020</a>	
ES 300h	<a href="#">2019</a>			
GS 450h	<a href="#">2014</a>	<a href="#">2015</a>	<a href="#">2018</a>	
LS 600h*	<a href="#">2013</a>	<a href="#">2014</a>	<a href="#">2015</a>	

\*The Hybrid Service Plug Grip noted in step 7 of repair manual, does not need to be removed

## VIII. DISASSEMBLE FUEL SUCTION TUBE ASSEMBLY

### DISASSEMBLY TIP: FOLLOW THE REPAIR MANUAL

The Part's Kit contains the necessary O-Rings for reassembly, if the Repair Manual procedure is followed. If the pump components are disassembled in a manner other than as detailed in the Repair Manual, the Parts Kit may not contain the necessary O-Rings for proper reassembly. Please follow the procedures in the Repair Manual to ensure the correct O-Rings are available.

#### Example of Proper Disassembly:

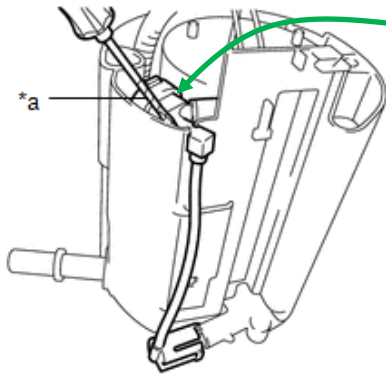

Repair Manual: Using a screwdriver (\*a) with its tip wrapped in protective tape, remove the jet pump from the No. 1 fuel sub-tank.

Tube still attached

Jet pump properly removed from the No.1 fuel sub-tank.

Replacement O-Ring will be installed in this location

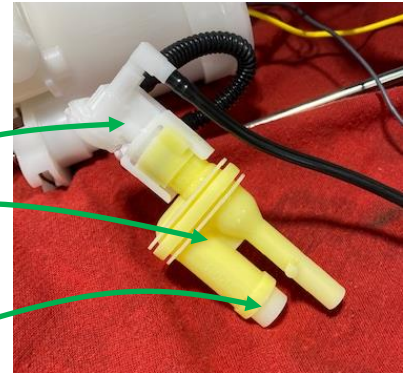

#### Example of Incorrect Disassembly:

Tube incorrectly removed from jet pump



Replacement O-ring is the incorrect size

DO NOT disconnect the tube from the jet pump

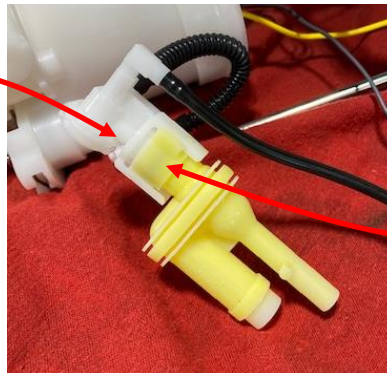

Replacement O-Ring is NOT provided for this location

## DISASSEMBLY TIP: MAIN VALVE AND REGULATOR

When replacing the fuel pump, it is not necessary to remove the Fuel Main Valve or Fuel Pressure Regulator. These O-Rings are NOT included in the parts kit.

**DO NOT** remove

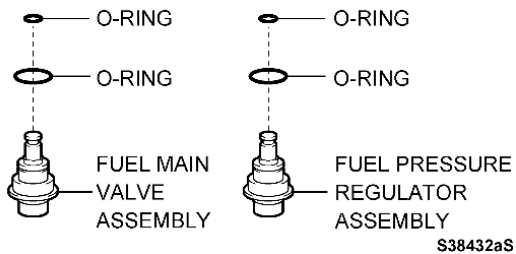

Incorrect Main Valve Assembly

Correct Main Valve Assembly



## DISASSEMBLY TIPS: FUEL FILTER

Many of the models will require the fuel filter to be reused. Be careful with the tabs when removing the filter from the original fuel pump as to not overextend them. When installing the filter on the **NEW** Fuel Pump, be sure that the clips have engaged properly.

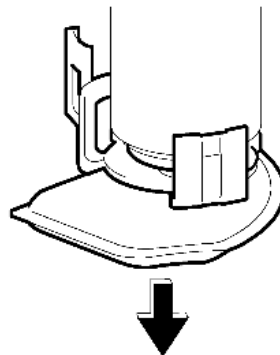

S38062aS

## DISASSEMBLY TIPS: O-RING REMOVAL

During disassembly, the O-Ring may remain in the fuel pump housing. Be sure to inspect the housing after removing the fuel pump and remove the O-Ring if necessary.

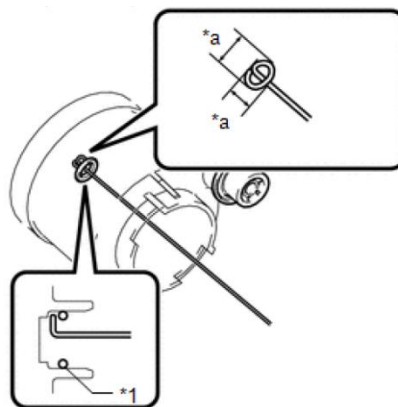

**1. DISASSEMBLE FUEL SUCTION TUBE ASSEMBLY**

a. Click the link below to access the repair manual instructions on TIS for disassembling the fuel suction tube assembly.

<b>DISASSEMBLY</b>				
RX 450h	<a href="#">2017</a>	<a href="#">2018</a>	<a href="#">2019</a>	<a href="#">2020</a>
RX 450hL	<a href="#">2018</a>	<a href="#">2019</a>	<a href="#">2020</a>	
ES 300h	<a href="#">2019</a>			
GS 450h	<a href="#">2014</a>	<a href="#">2015</a>	<a href="#">2018</a>	
LS 600h	<a href="#">2013</a>	<a href="#">2014</a>	<a href="#">2015</a>	

**2. CLEAN SUB TANK ASSEMBLY**

a. Using brake cleaner, clean the sub-tank assembly.

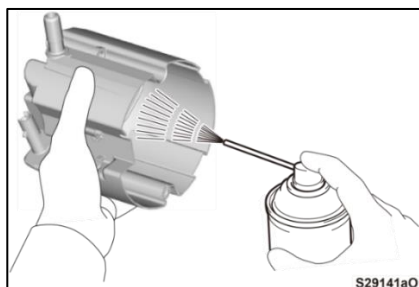

## IX. REASSEMBLE FUEL SUCTION TUBE ASSEMBLY

### REASSEMBLY TIPS: O-RINGS

The part kits may come with O-Rings of different sizes. They are very difficult to tell apart visually. To identify the different size O-Rings, they will be wrapped in individual plastic bags with a piece of **COLORED TAPE** sealing it. The **COLOR OF THE TAPE** will identify the O-Ring size.

**REFER TO THE COMPONENT DIAGRAMS IN THIS DOCUMENT TO DETERMINE TO CORRECT O-RING.**

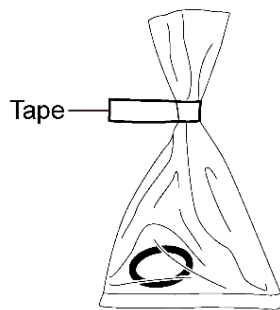

S38058aSU

### REASSEMBLY TIPS: FUEL TUBE

When assembling the upper and lower sections of the fuel pump assembly, be certain to correctly align the upper and lower sections as to not twist the fuel tube.



## REASSEMBLY TIPS: FUEL FILTER INSTALLATION

When assembling the fuel filter retainer to pump housing on some models, there is a possibility that the main valve will unseat itself from the housing. Be sure to inspect the complete assembly for the following issues:

- Crack in the retainer
- Claws are properly engaged
- O-Ring is properly seated
- No gap between the housing and main valve

### Filter Retainer Installation – Incorrect Assembly

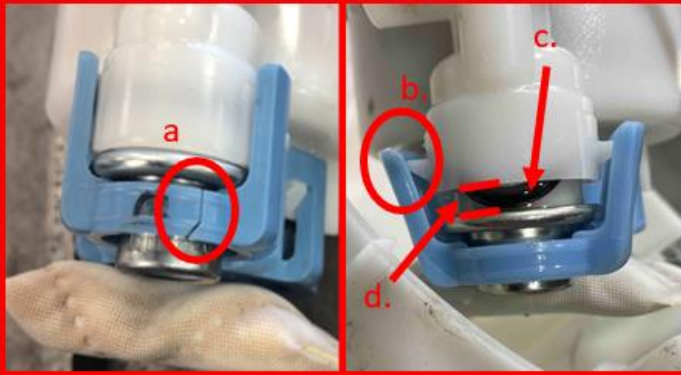

#### Incorrect Conditions:

- a. Crack in retainer
- b. Retainer claw below attachment point
- c. Incorrect position of O-Ring
- d. Gap visible between housing and valve

### Filter Retainer Installation – Correct Assembly



#### Good Condition

- e. Retainer claw secured above attachment point
- f. No visible gap or O-Ring between valve and housing



# 1. REASSEMBLE FUEL SUCTION TUBE ASSEMBLY WITH **NEW** FUEL PUMP

- a. Follow the TIS Repair Manual instructions to reassemble the Fuel Suction Tube Assembly with a **NEW** Fuel Pump.



Refer to the Component diagrams at the beginning of these Technical Instructions to confirm the location of each replacement part.

## Example Procedure:

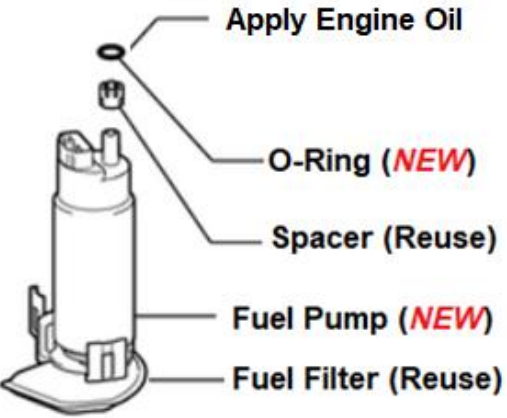
 <p><b>HINT:</b> The reused filter may be discolored.</p>	<ul style="list-style-type: none"><li>• Remove the original O-Ring, Spacer and Fuel Filter from the original Fuel Pump.</li><li>• Discard the original O-Ring and Fuel Pump, <u>saving the Spacer and Fuel Filter.</u></li><li>• Install the original Spacer onto the <b>NEW</b> Fuel Pump.</li><li>• Install the <b>NEW</b> O-Ring onto the <b>NEW</b> Fuel Pump. Refer to the Component Diagram to determine to proper O-Ring, as identified by the colored tape on the bag.</li><li>• Apply a small amount of engine oil to the <b>NEW</b> O-Ring to assure correct installation into the Tube Assembly.</li><li>• Install the original Fuel Filter onto the <b>NEW</b> Fuel Pump.</li><li>• Refer to the <u>Components diagrams</u> to review the other <b>NEW</b> parts to install.</li></ul>
--	--

- Apply engine oil to the **NEW** O-ring before assembly to assure correct installation into the Fuel Suction Tube.

**Note:** Fuel Pump O-Ring installation is critical to this repair. A visual inspection of the final assembly will confirm the correct installation.

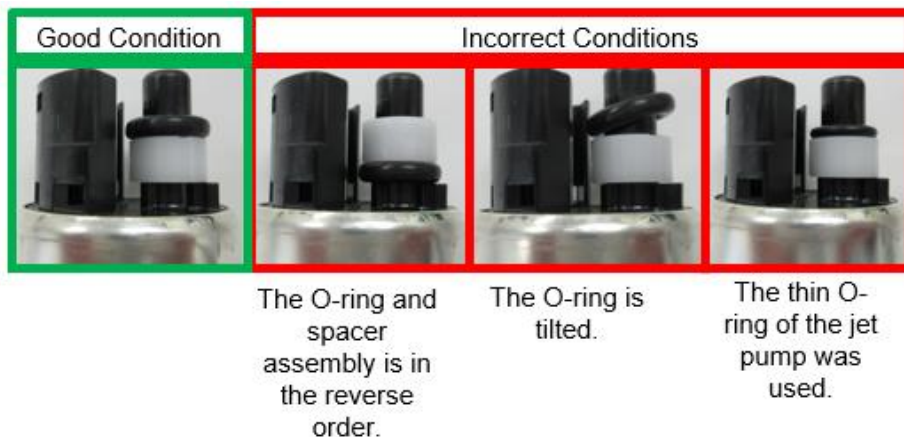

## 2. REASSEMBLE FUEL SUCTION TUBE ASSEMBLY

- a. Click the link below to access the repair manual instructions on TIS for reassembling the fuel suction tube assembly.

REASSEMBLY				
RX 450h	<a href="#">2017</a>	<a href="#">2018</a>	<a href="#">2019</a>	<a href="#">2020</a>
RX 450hL	<a href="#">2018</a>	<a href="#">2019</a>	<a href="#">2020</a>	
ES 300h	<a href="#">2019</a>			
GS 450h	<a href="#">2014</a>	<a href="#">2015</a>	<a href="#">2018</a>	
LS 600h	<a href="#">2013</a>	<a href="#">2014</a>	<a href="#">2015</a>	

## X. INSTALL FUEL SUCTION TUBE ASSEMBLY

### 1. INSTALL THE FUEL SUCTION TUBE ASSEMBLY INTO VEHICLE

- a. Click the link below to access the repair manual instructions on TIS for installing the fuel suction tube assembly into the vehicle.



**Refer to the Component diagrams at the beginning of these Technical Instructions to confirm the location of each replacement part.**

INSTALLATION				
RX 450h	<a href="#">2017</a>	<a href="#">2018</a>	<a href="#">2019</a>	<a href="#">2020</a>
RX 450hL	<a href="#">2018</a>	<a href="#">2019</a>	<a href="#">2020</a>	
ES 300h	<a href="#">2019</a>			
GS 450h	<a href="#">2014</a>	<a href="#">2015</a>	<a href="#">2018</a>	
LS 600h	<a href="#">2013</a>	<a href="#">2014</a>	<a href="#">2015</a>	

### 2. REMOVED FUEL

- a. If fuel was removed from the tank prior to disassembly, reinstall the originally recovered fuel into the tank.



### 3. CHECK FOR DTC'S

- a. Using a Techstream, perform a Health Check to check for Diagnostic Trouble Codes.

**Note:** *This Special Service Campaign covers only the replacement of the fuel pump and associated parts. It does not cover the diagnosis or replacement of any other parts on the vehicle.*



## ◀ VERIFY REPAIR QUALITY ▶

- Confirm that all parts listed in the Components Diagrams have been properly installed on the vehicle
- Confirm no fuel leaks from vehicle
- Confirm any fuel drained from the vehicle has been reinstalled
- Confirm no DTC's are present
- Test drive to confirm normal operation while under load

### XI. APPENDIX

#### A. PARTS DISPOSAL

In accordance with Federal law, please make sure all parts (original parts) removed from the vehicle are disposed of in a manner in which they will not be reused, **unless requested for parts recovery return.**

#### CAMPAIGN DESIGNATION DECORDER

