



Subject: Utilimaster has determined a defect relating to a crack at passenger's side interior door handle.

Customer: Multiple

Applies To: This bulletin applies to Velocity bodies built by Utilimaster on the Ford Transit chassis manufactured after October 8, 2019. Utilimaster Warranty Department to verify chassis VIN.

Correction: Add door plate to interior door handle.

Authorized to Perform the Work:

- Customer or customer contractor
- Utilimaster or Utilimaster contractor

Labor Allowance Up To: 0.25 hours **Job Op Code:** 03-GA-08-19-RW

Tools and Supplies Required:

Standard shop tools

⚠ CAUTION

Always wear safety glasses and other proper protective equipment (gloves, hearing protection, etc.) as appropriate to the process.

Parts Required:

BOM ID	Part Number	Description	Qty.
0	REFERENCE	DOOR CATCH 2-POS KIT (57552024C)	
10	06946278	DOOR PLATE	1
NS	03104479	DECAL SERVICED JOB CODE	1
NS	03105158-A007EN	DOOR PLATE INSTRUCTIONS	1

Technical Service Bulletins are intended for use by Professional Technicians only. They are written to guide Professional Technicians in performing service to vehicles of product specific nature in conjunction with industry standards. Professional Technicians are appropriately trained on industry standards and have the tools and equipment to perform procedures safely and properly.

Procedure:

1. Read and understand all the instructions before starting the repair.
2. Disassemble and remove passenger's side interior door handle. Exterior door handle does not need to be removed.
3. Align door plate to the interior of the door handle.
4. Assemble door handle to the door.
5. Torque 1/4-20 nuts to 7–8 lb•ft.
6. Cycle door to confirm latch secures with catch.

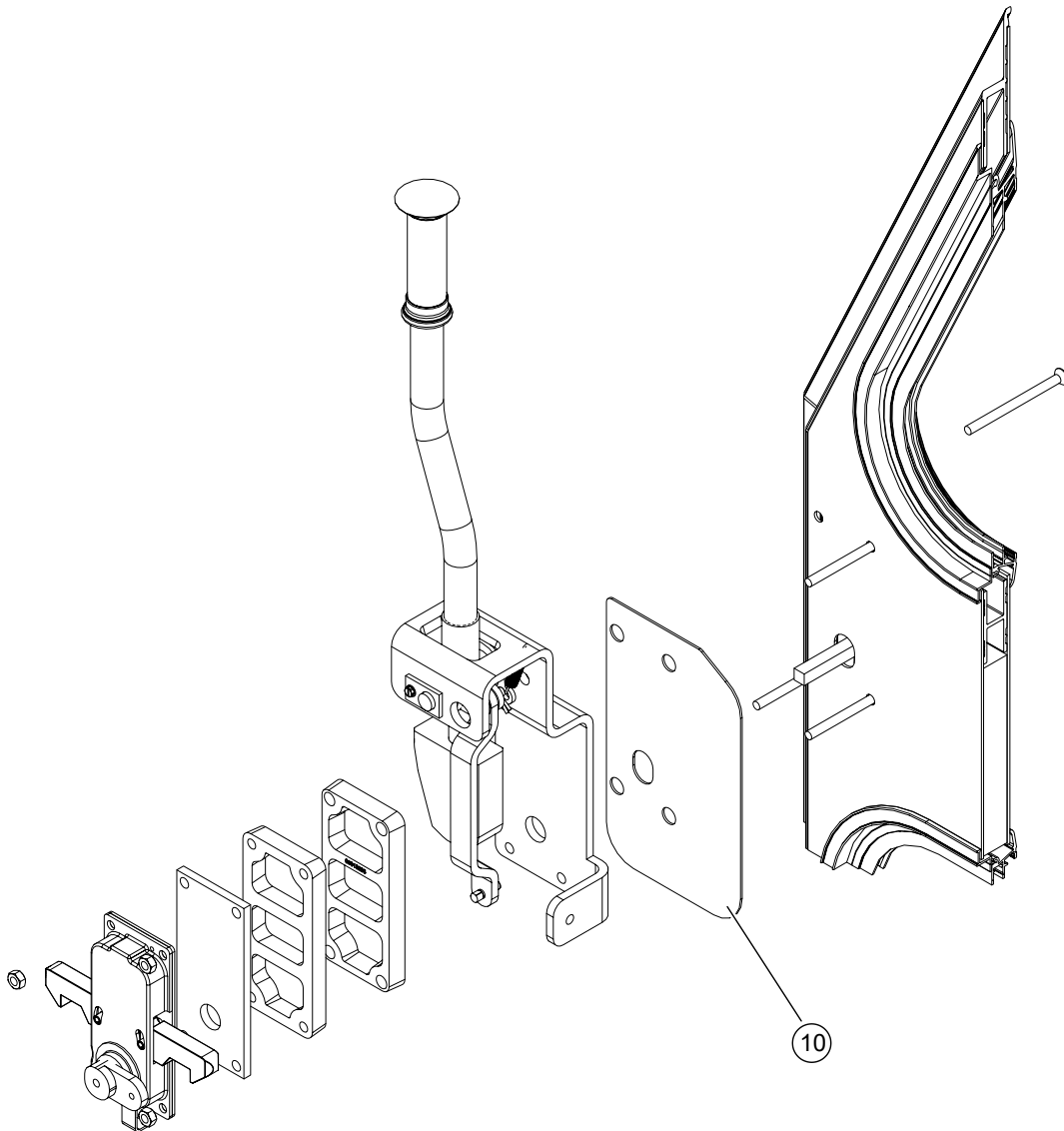

Handle Assembly

7. Use Job Code 03-GA-08-19-RW from this document to complete the SERVICED decal.
8. Adhere the decal to the upper right-hand corner of the driver's door pocket panel or sidewall next to the bulkhead wall. Do NOT cover any previously applied decals.



Service decal on driver's door pocket (cargo side)

NOTE: In order to be reimbursed for labor, the repair **MUST** be completed and warranty claim filed within one year from the initial date of this publication.

File Warranty By: August 5, 2022

Contact Utilimaster to Order Parts and File Warranty

Email: FVSWarranty@Utilimaster.com

Mail or Express Service:

Utilimaster
 Attn: Warranty Dept.
 603 Earthway Blvd.
 Bristol, IN 46507 USA

Phone: 800-237-7806

Fax: 574-848-2800

This material is confidential and the property of The Shyft Group, Inc. (Shyft) It is shared with your company for the sole purpose of helping you with the operation of the described equipment. Shyft makes no warranty of any kind with regard to this material, including, but not limited to, the implied warranties of merchantability and fitness for a particular purpose.

Shyft shall not be liable for errors contained herein or for incidental or consequential damages in connection with the furnishing, performance, or use of this material. Shyft expressly disclaims all responsibility and liability for the installation, use, performance, maintenance, and support of third-party products. Customers are advised to make their independent evaluation of such products. No part of this document may be photocopied, reproduced, or translated to another language without the prior written consent.

All products or name brands mentioned in this document are trademarks of their respective owners.