

Service Alert

Mazda North American Operations
Irvine, CA 92618-2922



Subject: CONNECTED VEHICLE REMOTE FUNCTIONS INOPERATIVE AND/OR ENGINE NO START DUE TO LOW BATTERY VOLTAGE	Service Alert No.: SA-045/21
	Last Issued : 08/02/2021

BULLETIN NOTES

This Service Alert supersedes the previously issued Service Alert(s) listed below: The changes are noted in Red.

Previous Service Alert(s):	Date(s) Issued:
SA-045/21	07/23/21

APPLICABLE MODEL(S)/VINS

- 2021 Mazda3 vehicles built July 1, 2021 and later
- 2021 CX30 vehicles built July 1, 2021 and later
- 2021 CX-5 vehicles built March 19, 2021 and later
- 2021 CX-9 vehicles built March 19, 2021 and later

DESCRIPTION

Some customers may experience the following symptoms:

- Connected Vehicle Remote Functions inoperative after SSPC6 repair.
- Connected Vehicle Remote Functions inoperative on vehicles built July 1, 2021 and later.
- Engine no start due to low battery voltage.

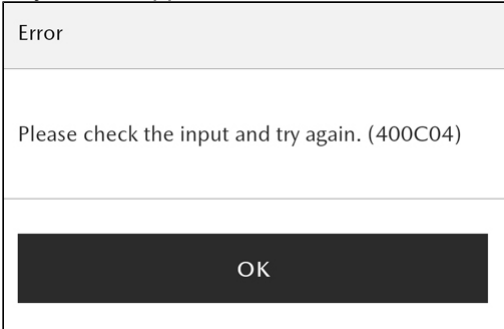
Connected Vehicle Remote function(s) inoperative. <ul style="list-style-type: none">• Engine Start / Stop• Door Lock / Unlock• Lights ON / OFF	The MyMazda App will show remote function error
	

CONSUMER NOTICE: The information and instructions in this bulletin are intended for use by skilled technicians. Mazda technicians utilize the proper tools/ equipment and take training to correctly and safely maintain Mazda vehicles. These instructions should not be performed by "do-it-yourselfers." Customers should not assume this bulletin applies to their vehicle or that their vehicle will develop the described concern. To determine if the information applies, customers should contact their nearest authorized Mazda dealership. Mazda North American Operations reserves the right to alter the specifications and contents of this bulletin without obligation or advance notice. All rights reserved. No part of this bulletin may be reproduced in any form or by any means, electronic or mechanical---including photocopying and recording and the use of any kind of information storage and retrieval system ---without permission in writing.

NOTE:

- Connected Vehicle reception strength icon shows normal.
- CV Viewer shows normal customer enrollment information.

**REPAIR PROCEDURE****Preparation**

1. Prepare four (4) individual USB memory sticks and label them as shown in the table.
2. Delete all files from the USB memory sticks.
3. Download the following files to each individual USB memory stick by model.

Model	File Name and Link	Software Version	USB Memory Stick
Mazda3	Coming Soon	10004	
CX-30	TCU_7000T11-0601_8004.kwi	10004	
CX-5	TCU_7000T11-0301_8014.kwi	10020	
CX-9	TCU_7000T11-0201_8014.kwi	10020	

NOTE:

- Each USB memory stick should only have one (1) file on it. If two or more files exist on the USB memory stick, no file is recognized for the reprogramming.
- Advise the customer to NOT use the remote control features (remote engine start/stop, remote door lock/unlock, turn on /off hazard warning lights) with the MyMazda App during the repair. The malfunction information may be sent for the DTC detected during the repair.

CONSUMER NOTICE: The information and instructions in this bulletin are intended for use by skilled technicians. Mazda technicians utilize the proper tools/ equipment and take training to correctly and safely maintain Mazda vehicles. These instructions should not be performed by "do-it-yourselfers." Customers should not assume this bulletin applies to their vehicle or that their vehicle will develop the described concern. To determine if the information applies, customers should contact their nearest authorized Mazda dealership. Mazda North American Operations reserves the right to alter the specifications and contents of this bulletin without obligation or advance notice. All rights reserved. No part of this bulletin may be reproduced in any form or by any means, electronic or mechanical--including photocopying and recording and the use of any kind of information storage and retrieval system ---without permission in writing.

Reprogramming the Telematics Communication Unit (TCU).

1. Maintain battery voltage using a the DCA8000 or GR8 battery charger. See SA-034/21.
2. Turn the ignition switch to ACC.
- CAUTION:** To avoid damaging the TCU, DO NOT turn the ignition switch to OFF or disconnect the battery terminal during reprogramming.
3. Insert the USB memory stick by model into the USB port located in the center console.

4. Press and hold the Volume knob, then press and hold the Entertainment and Favorites buttons at the same time for 3-5 seconds and the Factory/Service Inspection screen will appear.

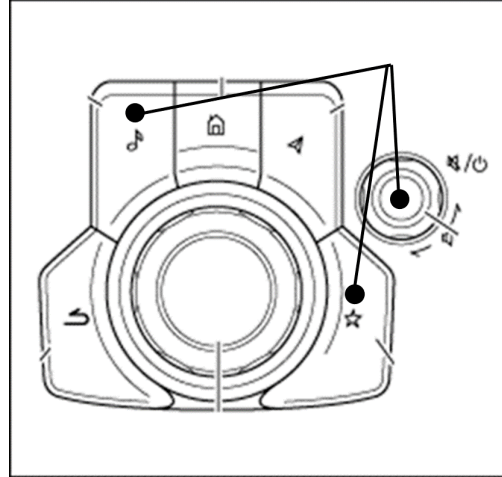

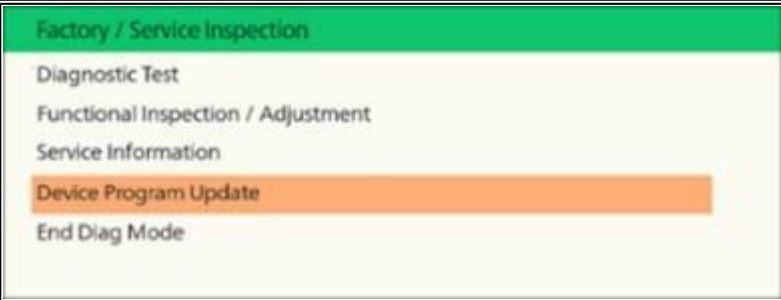

5. Select "Device Program Update".

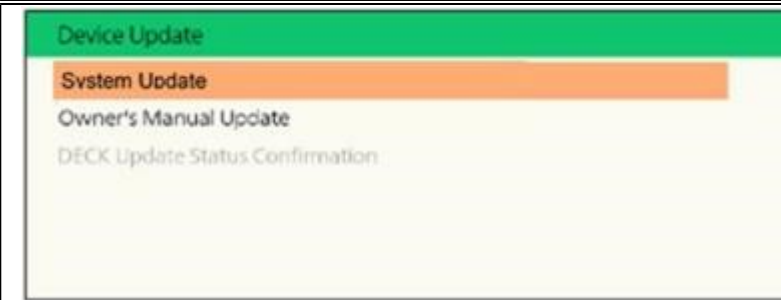

6. Select "System Update".

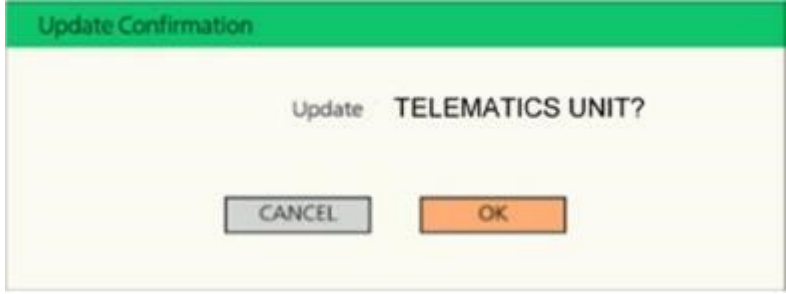
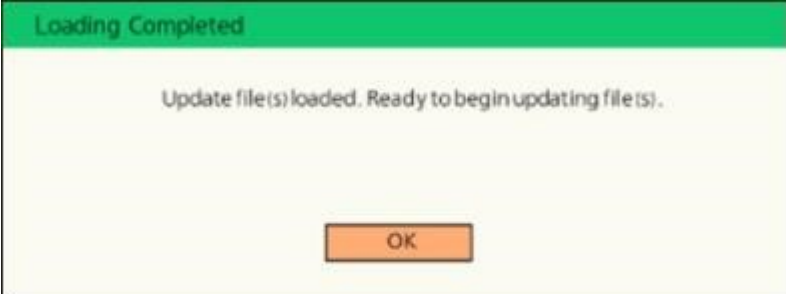
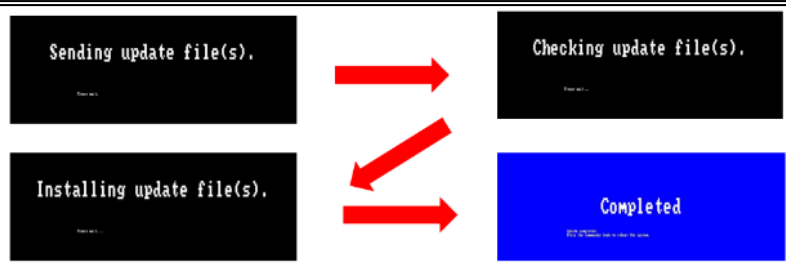

CONSUMER NOTICE: The information and instructions in this bulletin are intended for use by skilled technicians. Mazda technicians utilize the proper tools/ equipment and take training to correctly and safely maintain Mazda vehicles. These instructions should not be performed by "do-it-yourselfers." Customers should not assume this bulletin applies to their vehicle or that their vehicle will develop the described concern. To determine if the information applies, customers should contact their nearest authorized Mazda dealership. Mazda North American Operations reserves the right to alter the specifications and contents of this bulletin without obligation or advance notice. All rights reserved. No part of this bulletin may be reproduced in any form or by any means, electronic or mechanical---including photocopying and recording and the use of any kind of information storage and retrieval system ---without permission in writing.

<p>7. Select "USB" and the system will start checking for the update file.</p>	
<p>8. Confirm the correct software version is shown under "Update Version" and select "TELEMATICS UNIT".</p>	
<p>9. Select "OK" on the screen and wait until the update (loading) is completed. NOTE: DO NOT switch ignition OFF until the update (loading) is completed.</p>	
<p>10. Select "OK" on the screen. NOTE:</p> <ul style="list-style-type: none"> • The data update will start automatically after 10 seconds if "OK" is not selected. • After selecting "OK", the system will reboot and the display will turn black, followed by a "Verifying update file(s)" screen. 	
<p>11. Wait until update is completed. NOTE: The system will reboot several times during the update process.</p>	

CONSUMER NOTICE: The information and instructions in this bulletin are intended for use by skilled technicians. Mazda technicians utilize the proper tools/ equipment and take training to correctly and safely maintain Mazda vehicles. These instructions should not be performed by "do-it-yourselfers." Customers should not assume this bulletin applies to their vehicle or that their vehicle will develop the described concern. To determine if the information applies, customers should contact their nearest authorized Mazda dealership. Mazda North American Operations reserves the right to alter the specifications and contents of this bulletin without obligation or advance notice. All rights reserved. No part of this bulletin may be reproduced in any form or by any means, electronic or mechanical---including photocopying and recording and the use of any kind of information storage and retrieval system ---without permission in writing.

12. Press the commander knob to reboot the system.
13. After rebooting is completed, remove the USB memory stick from the USB port.
14. Same as step 4, move to Factory/Service Inspection screen.
15. Select Service Information.

16. Select TCU Linked Information, then scroll down to TCU Software Version.
17. Confirm that the TCU software version has been updated.

- CX-5, CX-9 - 10020
- Mazda3, CX-30 - 10004

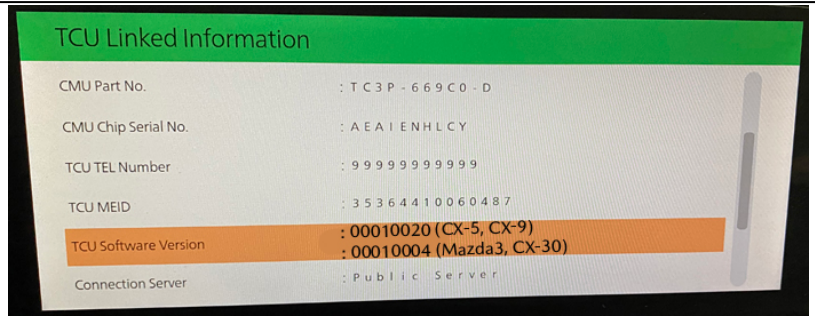

18. Push Return multiple times to return to the top page of Factory/Service Inspection screen, then select End Diag Mode to return to the normal infotainment screen.
19. Check for DTCs with the Mazda Modular Diagnostic System (M-MDS) using Mazda Diagnostic And Repair Software (MDARS). If any are present, clear them.
20. Switch the ignition OFF.

21. Verify repair.	Customer is enrolled into connected vehicle services.	<p>At vehicle pickup, use the customer's phone and the MyMazda App to confirm connected vehicle remote functions operate normally.</p> <ul style="list-style-type: none"> • Engine Start / Stop • Door Lock / Unlock • Lights ON / OFF
	Customer is not enrolled into connected vehicle services.	<p>Confirm connected vehicle reception strength icon shows good strength.</p>

CONSUMER NOTICE: The information and instructions in this bulletin are intended for use by skilled technicians. Mazda technicians utilize the proper tools/ equipment and take training to correctly and safely maintain Mazda vehicles. These instructions should not be performed by "do-it-yourselfers." Customers should not assume this bulletin applies to their vehicle or that their vehicle will develop the described concern. To determine if the information applies, customers should contact their nearest authorized Mazda dealership. Mazda North American Operations reserves the right to alter the specifications and contents of this bulletin without obligation or advance notice. All rights reserved. No part of this bulletin may be reproduced in any form or by any means, electronic or mechanical--including photocopying and recording and the use of any kind of information storage and retrieval system ---without permission in writing.

WARRANTY INFORMATION

Warranty Type	A
Symptom Code	64
Damage Code	9W
Part Number Main Cause	5555-21-005A
Quantity	0
Operation Number / Labor Hours:	YY823XRX / 0.4 Hrs

CONSUMER NOTICE: The information and instructions in this bulletin are intended for use by skilled technicians. Mazda technicians utilize the proper tools/ equipment and take training to correctly and safely maintain Mazda vehicles. These instructions should not be performed by "do-it-yourselfers." Customers should not assume this bulletin applies to their vehicle or that their vehicle will develop the described concern. To determine if the information applies, customers should contact their nearest authorized Mazda dealership. Mazda North American Operations reserves the right to alter the specifications and contents of this bulletin without obligation or advance notice. All rights reserved. No part of this bulletin may be reproduced in any form or by any means, electronic or mechanical---including photocopying and recording and the use of any kind of information storage and retrieval system ---without permission in writing.