



SIB 34 03 20 SERVICE ACTION: ABS Modulator Mounting Bolt

2021-06-14

This Service Information Bulletin replaces SI 34 03 20 **dated October 2020**.

Please perform the procedure outlined in this Service Information on all affected vehicles before customer delivery. In the event the customer has already taken delivery of the vehicle, please perform the procedure at the next service visit.

MODEL

E-Series	Model Description	Production Date
K69	S 1000 XR	before July 17, 2020

The affected vehicles have been marked with campaign number 0034780000

In order to determine if a specific vehicle is affected by this campaign it will be necessary to verify the vehicle VIN in AIR (Aftersales Information Research). Based on the response of the system, either proceed with the repair or take no further action. Please note, open campaigns may not appear in DCS Warranty Vehicle Inquiry or sales systems until 24-72 hours after they are announced, therefore AIR is always the recommended method for determining open campaigns.

SITUATION

During assembly, an additional mounting bolt was installed on the ABS pressure modulator instead of a plastic rivet. This changes the vibration behavior of the ABS modulator. When the motorcycle is frequently used at very high engine speeds, vibration damage to the components could occur.

CORRECTION

The additional bolt must be removed and a plastic fastener (rivet) must be installed in its place.

PROCEDURE

For vehicles that are affected, please replace the bolt by following repair instruction "00 60 369 – Screw connection ABS pressure modulator", attached.

PARTS INFORMATION

Part Number	Description	Quantity
61 21 7 659 147	Plastic Rivet	1

WARRANTY INFORMATION

Covered under the terms of the BMW New Vehicle Limited Warranty for Motorcycles and Scooters.

Defect code

00 34 78 00 00	Replacing ABS pressure modulator mounting bolt
----------------	--

Labor Operation

+00 60 869	Screw connection for ABS pressure modulator	11 FRU
------------	---	--------

FRUs includes all repair procedures to complete the task with allowance for necessary ancillary tasks (e.g., visual inspection, lubrication, cleaning parts etc.) and administrative tasks.

QUESTIONS REGARDING THIS BULLETIN

Technical inquires	Contact the BMW Technical Support Group via TSARA
Warranty inquires	Submit an IDS ticket to the Warranty Department
Parts inquires	Submit an IDS ticket to the Motorrad Parts Department

Supporting Materials

[picture_as_pdf 34 03 20 Service Action - ABS Modulator Mounting Bolt.pdf](#)

[picture_as_pdf RM_0060369_0034780000_EN.pdf](#)

Service Information Bulletin

Brakes

June 14, 2021

34 03 20

SERVICE ACTION: ABS MODULATOR MOUNTING BOLT



**BMW
MOTORRAD**

This Service Information Bulletin replaces SI 34 03 20 **dated October 2020**.

Please perform the procedure outlined in this Service Information on all affected vehicles before customer delivery. In the event the customer has already taken delivery of the vehicle, please perform the procedure at the next service visit.

MODEL

E-Series	Model Description	Production Date
K69	S 1000 XR	before July 17, 2020

The affected vehicles have been marked with campaign number 0034780000

In order to determine if a specific vehicle is affected by this campaign it will be necessary to verify the vehicle VIN in AIR (Aftersales Information Research). Based on the response of the system, either proceed with the repair or take no further action. Please note, open campaigns may not appear in DCS Warranty Vehicle Inquiry or sales systems until 24-72 hours after they are announced, therefore AIR is always the recommended method for determining open campaigns.

SITUATION

During assembly, an additional mounting bolt was installed on the ABS pressure modulator instead of a plastic rivet. This changes the vibration behavior of the ABS modulator. When the motorcycle is frequently used at very high engine speeds, vibration damage to the components could occur.

CORRECTION

The additional bolt must be removed and a plastic fastener (rivet) must be installed in its place.

PROCEDURE

For vehicles that are affected, please replace the bolt by following repair instruction "00 60 369 – Screw connection ABS pressure modulator", attached.

PARTS INFORMATION

Part Number	Description	Quantity
61 21 7 659 147	Plastic Rivet	1

WARRANTY INFORMATION

Covered under the terms of the BMW New Vehicle Limited Warranty for Motorcycles and Scooters.

Defect code

00 34 78 00 00	Replacing ABS pressure modulator mounting bolt
----------------	--

Labor Operation

+00 60 869	Screw connection for ABS pressure modulator	11 FRU
------------	---	--------

FRUs includes all repair procedures to complete the task with allowance for necessary ancillary tasks (e.g., visual inspection, lubrication, cleaning parts etc.) and administrative tasks.

QUESTIONS REGARDING THIS BULLETIN

Technical inquires	Contact the BMW Technical Support Group via TSARA
Warranty inquires	Submit an IDS ticket to the Warranty Department
Parts inquires	Submit an IDS ticket to the Motorrad Parts Department

0E41 - S 1000 XR

00 60 369 Screw connection for ABS pressure modulator

– without centre stand^{OE} (0636)

Additional work: 46 52 510 Removing and installing the rear-wheel stand special tool (motorcycles without centre stand)◇

1

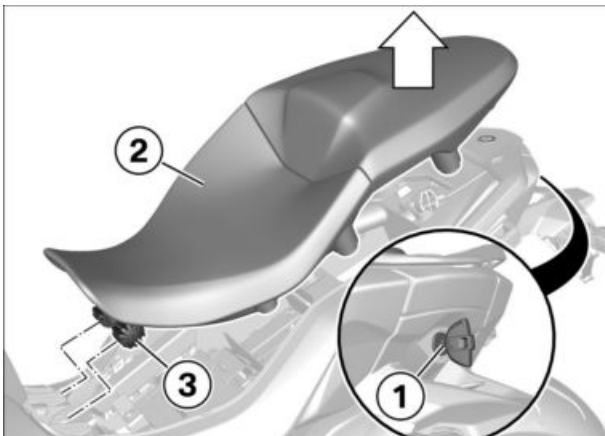

► Removing seat

- Unlock seat lock **(1)** with ignition key, lift seat **(2)** at rear and remove with buffers **(3)** from holder.



2

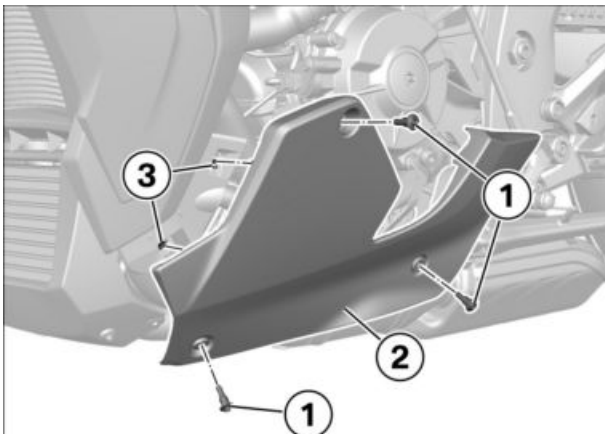

► Removing left engine spoiler

- Remove screws **(1)**.
- Loosen engine spoiler **(2)** from mounting clips **(3)** and remove.



3

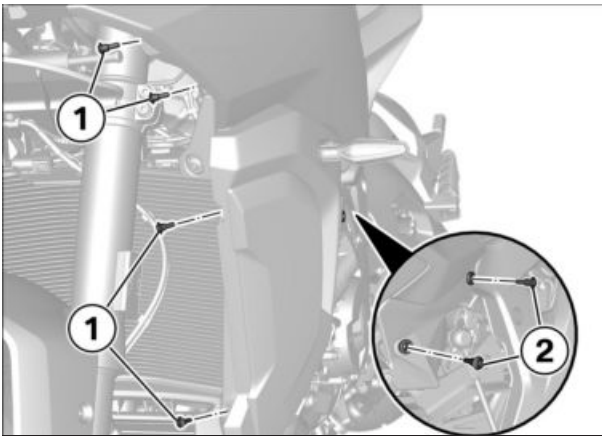

► Removing left side panel

- Remove screws (1) and screws (2).

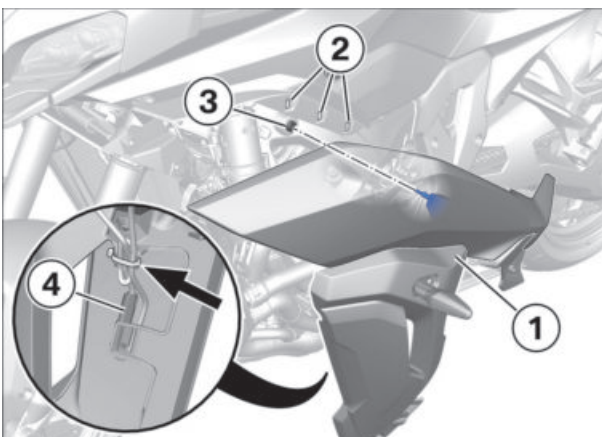

- Pull left fairing side panel (1) out of mounting clips (2) and rubber grommet (3).
- Open the cable strap (arrow).
- Remove and disconnect plug connection (4) for left turn indicator.

4

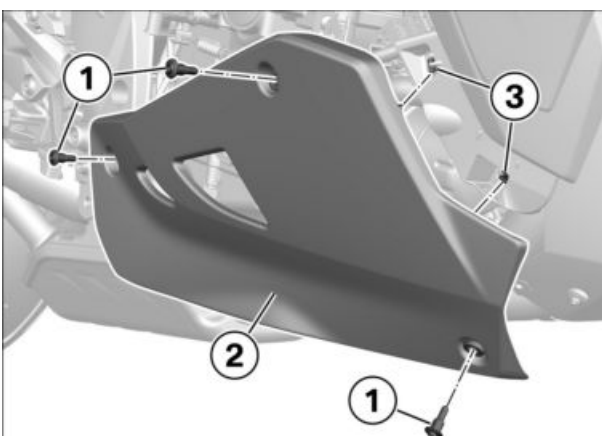

► Removing right engine spoiler

- Remove screws (1).
- Loosen engine spoiler (2) from mounting clips (3) and remove.

5

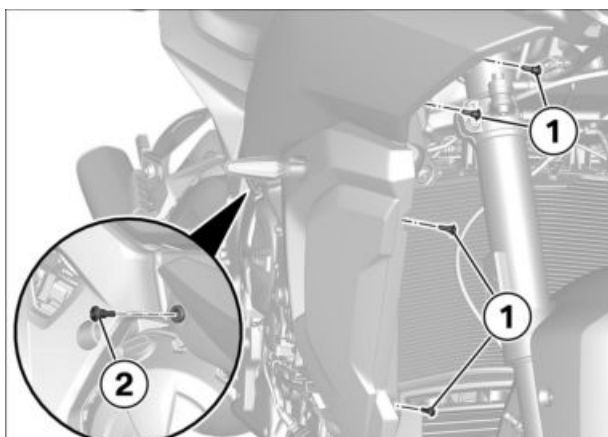

► Removing right side panel

- Remove nuts **(1)** and screws **(2)**.

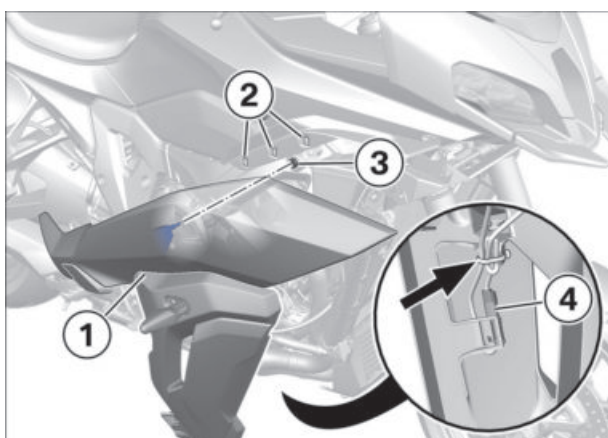

- Pull right fairing side panel **(1)** out of mounting clips **(2)** and rubber grommet **(3)**.
- Open the cable strap **(arrow)**.
- Remove and disconnect plug connection **(4)** for right turn indicator.

6

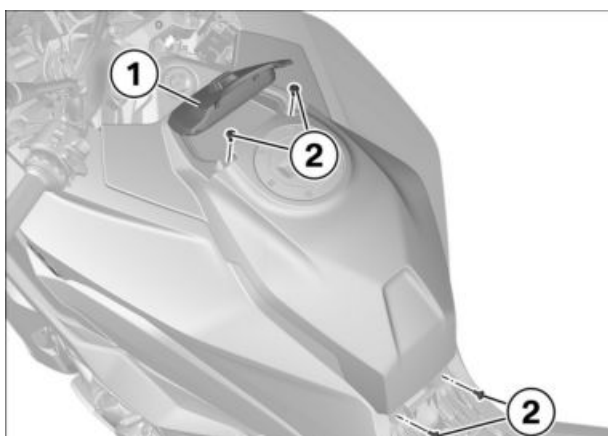

► Removing the centre cover of fuel tank

- Open storage compartment lid **(1)**.
- Remove screws **(2)**.

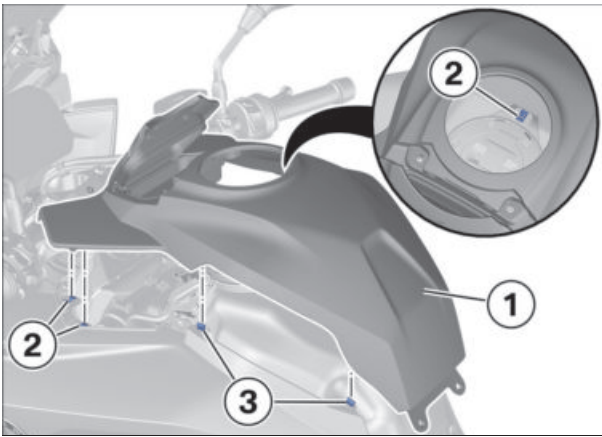

- Remove cover (1) to the top, detaching it from the retaining clips (2) and from the retaining lugs (3) on the left and right.

7

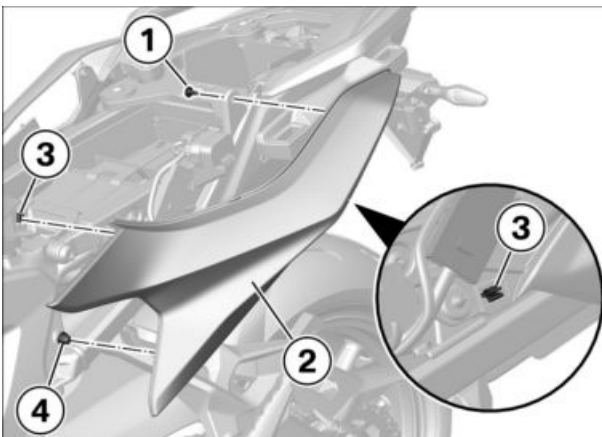

► **Removing left rear trim panel**

- Remove bolt (1).
- Detach rear trim panel (2) from retaining clips (3) and retaining pin (4) and remove.

8

► **Removing front left inner cover**

Requirement

Windscreen in upper position

ATTENTION

Use of hard or sharp-edged objects in proximity to component

Component damage

- Take care not to scratch components; cover or mask as necessary.

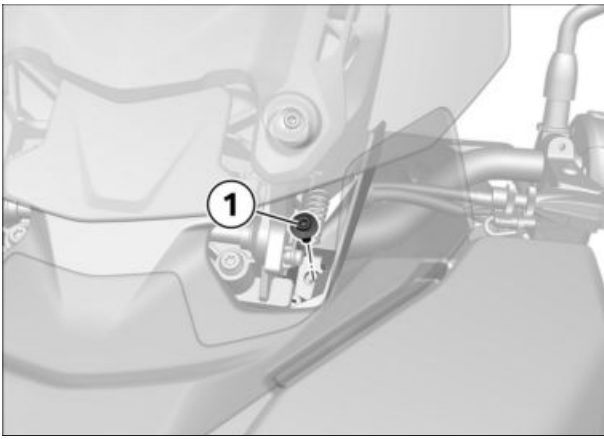

- Remove bolt **(1)**.

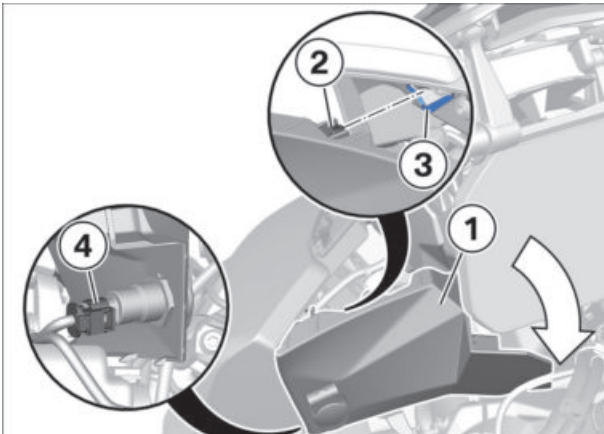

- Swing front left inner cover **(1)** to the back detaching mounting clip **(2)** from recess **(3)**.
- Pull inboard cover **(1)** to the back and disconnect connector **(4)** for 12 Volt power socket.
- Remove inboard cover **(1)**.



9

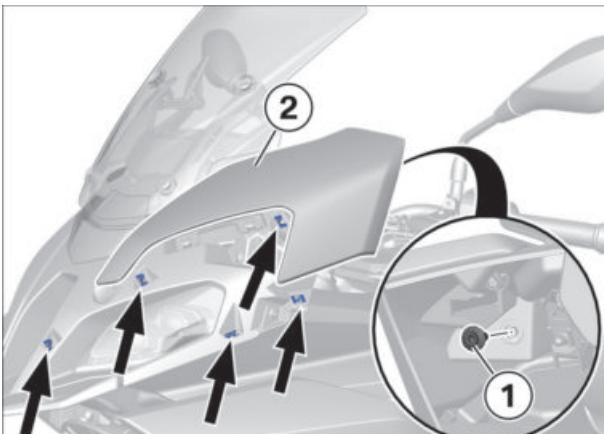

► Removing top trim panel, left

- Remove bolt **(1)**.
- Detach fairing top section **(2)** from retaining clips **(arrows)** and remove.



10

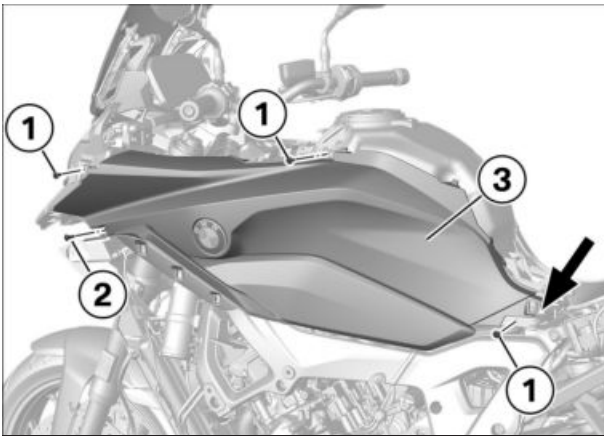

► Removing left cover of fuel tank

- Remove nuts **(1)** and screws **(2)**.
- Detach fuel tank cover **(3)** on left from fuel tank **(arrow)** and remove.

11

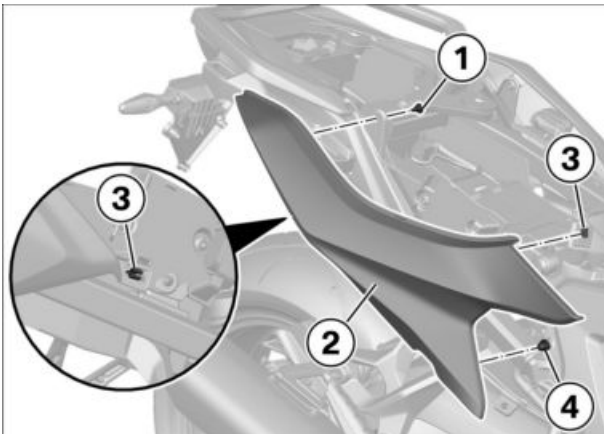

► Removing right rear trim panel

- Remove bolt **(1)**.
- Detach rear trim panel **(2)** from retaining clips **(3)** and retaining pin **(4)** and remove.

12

► Removing front right inner cover

Requirement

Windscreen in upper position

ATTENTION

Use of hard or sharp-edged objects in proximity to component

Component damage

- Take care not to scratch components; cover or mask as necessary.

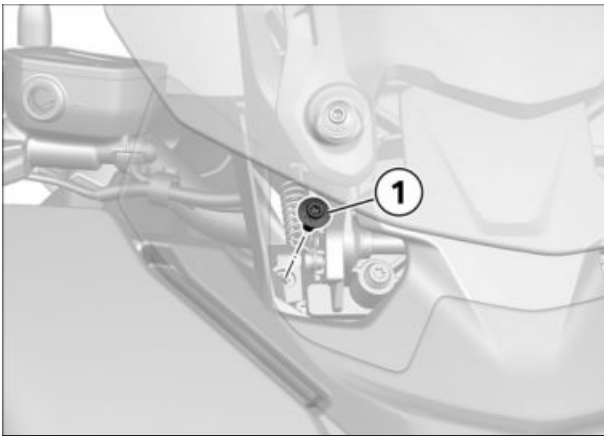

- Remove bolt **(1)**.

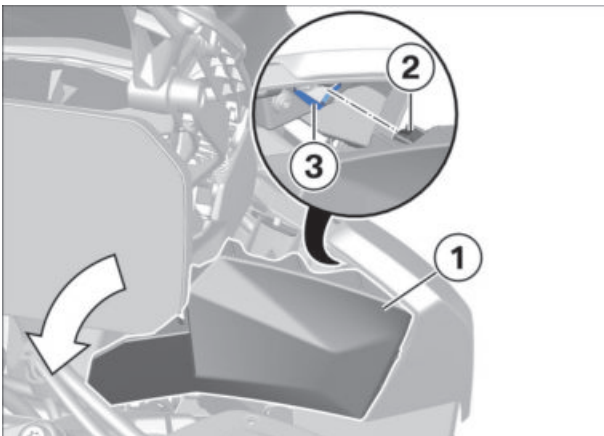

- Swing front right inner cover **(1)** to the back detaching mounting clip **(2)** from recess **(3)**.
- Remove inboard cover **(1)**.

13

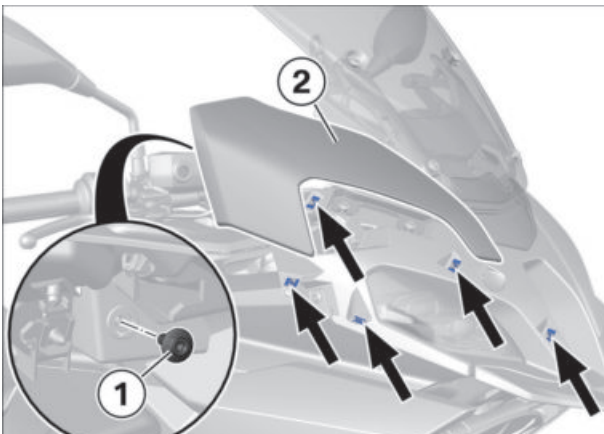

► Removing top section of fairing, right

- Remove bolt **(1)**.
- Detach fairing top section **(2)** from retaining clips **(arrows)** and remove.

14

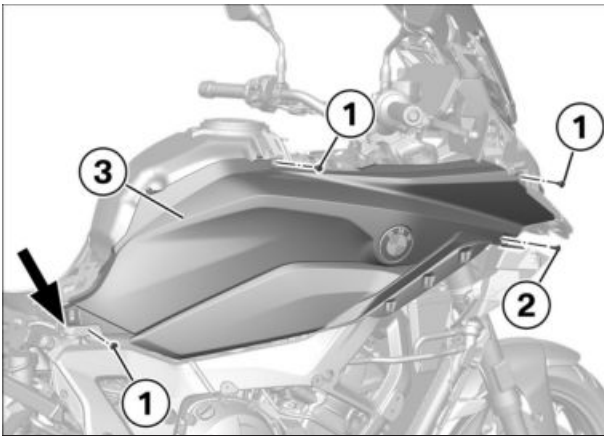

► Removing right fuel-tank cover

- Remove nuts **(1)** and screws **(2)**.
- Detach fuel tank cover **(3)** on right from fuel tank **(arrow)** and remove.

15

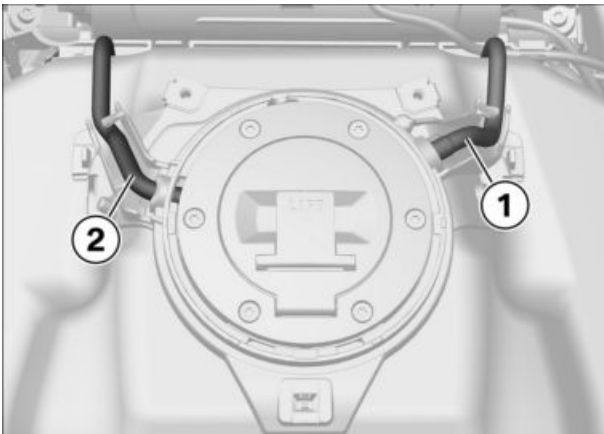

► Removing fuel tank

- Pull off hoses **(1)** for tank ventilation and **(2)** for waste water.

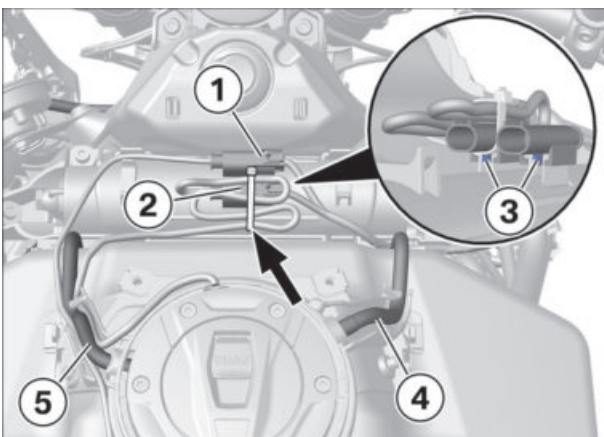

– with Keyless Ride^{OE} (0193)

- Remove cable strap **(arrow)**.
- Disconnect plug connection **(1)** for ring aerial and plug connection **(2)** for fuel filler cap.
- Unlock locks **(3)** and remove connector **(1)** for ring aerial and connector **(2)** for fuel filler cap.
- Pull off hoses **(4)** for tank ventilation and **(5)** for waste water.◊

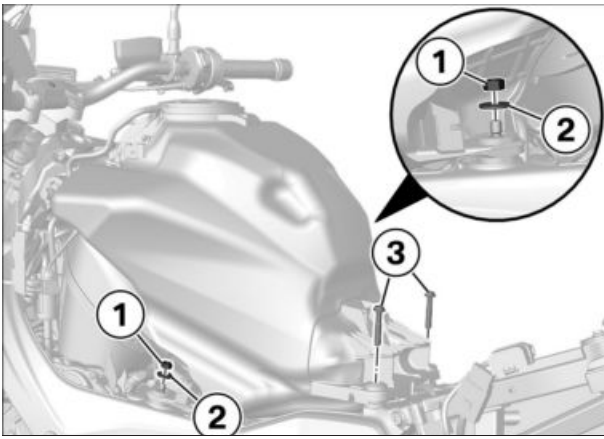

- Remove nuts **(1)** with washers **(2)**.
- Remove screws **(3)**.

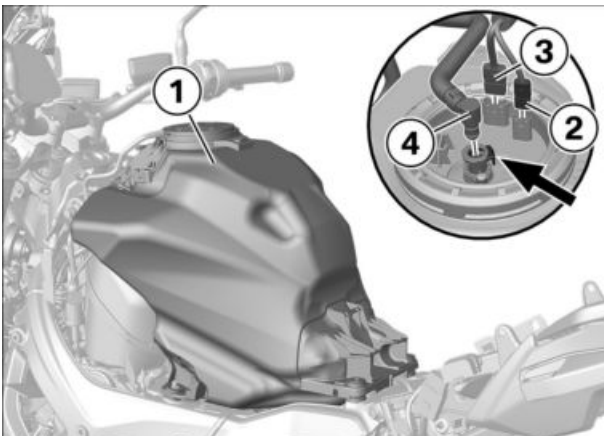

- Lift the fuel tank **(1)**.
- Disconnect plug connection **(3)** for fuel level sensor and plug connection **(2)** for electric fuel pump.
- Press open the lock of the fuel delivery line **(Arrow)** and disconnect fuel delivery line **(4)**.
- Remove fuel tank **(1)**.

16

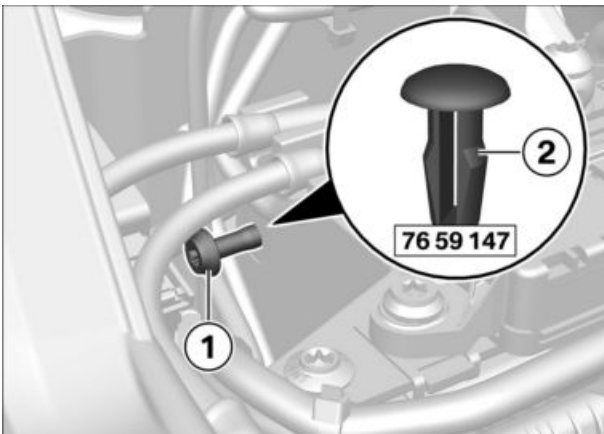

► Replacing bolt on holder for pressure modulator with plastic rivet

- Remove bolt **(1)** and close up bore hole with plastic rivet **(2)**.

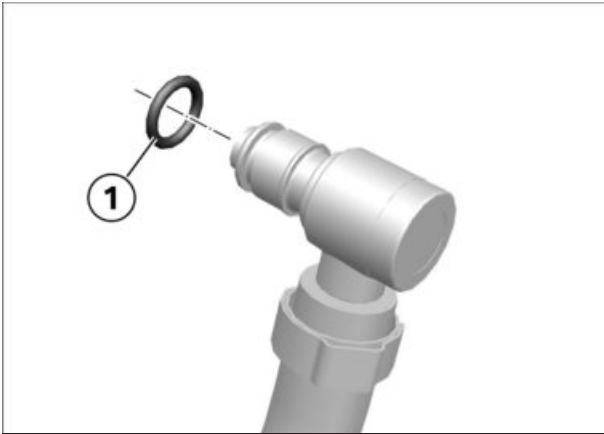

► Installing fuel tank

- Check O-ring of fuel delivery line **(1)** for damage; replace if necessary.

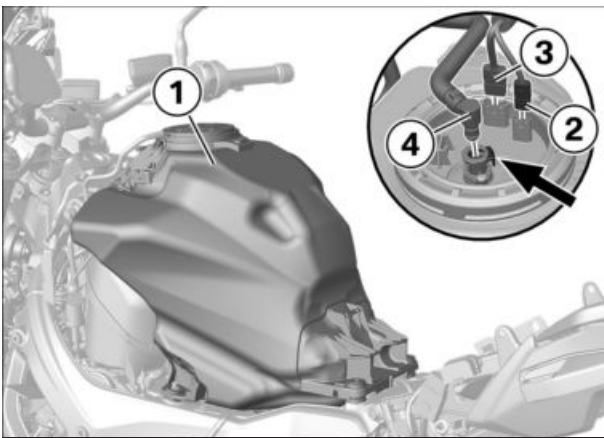

- Position fuel tank **(1)**.

ATTENTION

Application of force to close locked quick-action couplings

Leak due to damaged O-rings

- Close the quick-action coupling of the fuel line only with the latch open/pressed.
- Press open the lock for the fuel delivery line (**Arrow**) and push fuel delivery line **(4)** into bush with slight pressure. Release the latch and check that the delivery line is correctly seated.
- Connect plug connection **(3)** for fuel level sensor and plug connection **(2)** for electric fuel pump.
- Positioning fuel tank **(1)**.
- Install screws **(3)** and nuts **(1)** with washers **(2)**.

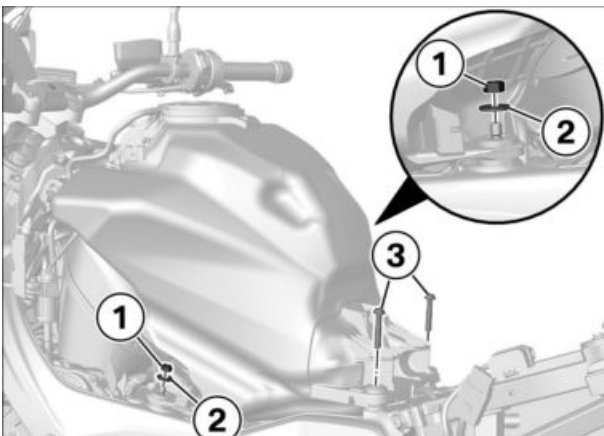

 Tightening torques		
Fuel tank to frame		
Nut, M8	19 Nm	
Screw, M8 x 45	19 Nm	

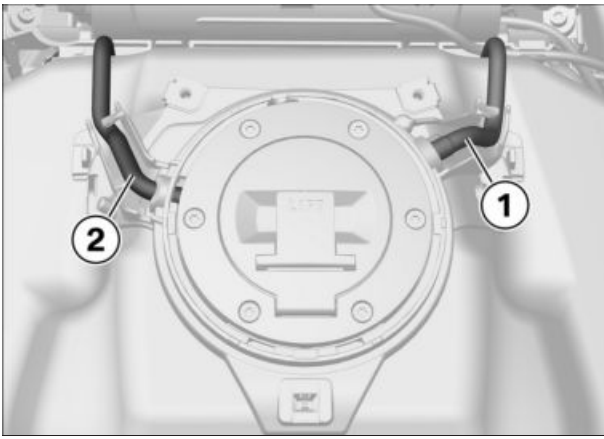

- Slide on hoses **(1)** for tank ventilation and **(2)** for waste water.

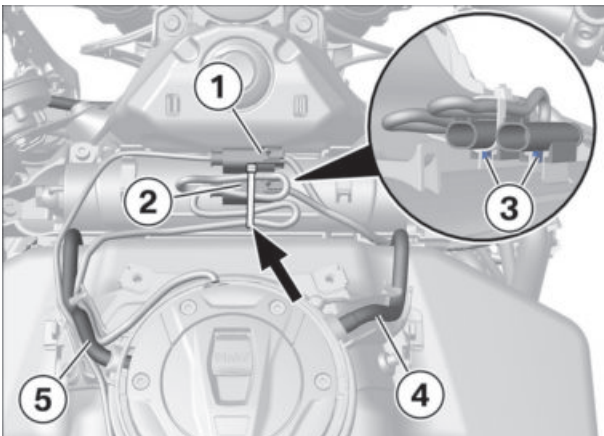

- with Keyless Ride^{OE} (0193)
- Slide on hoses **(4)** for tank ventilation and **(5)** for waste water.
- Install connector **(1)** for ring aerial and connector **(2)** for fuel filler cap making sure that locks **(3)** engage.
- Connect plug connection **(1)** for ring aerial and plug connection **(2)** for fuel filler cap.
- Secure the cable strap **(arrow)**.◇

18

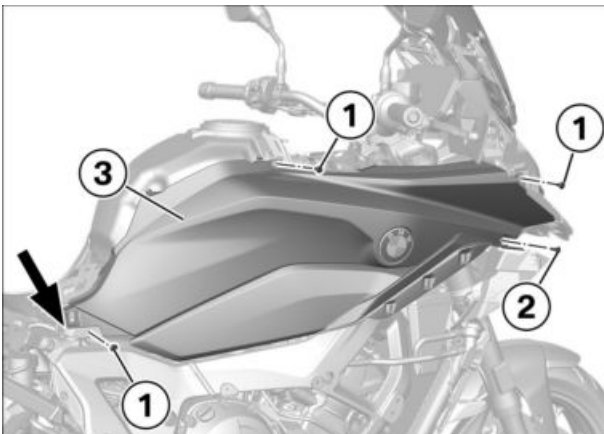

► Installing right fuel-tank cover

- Attach fuel tank cover **(3)** on right on fuel tank **(arrow)** and install.
- Install screws (short collar) **(1)** and screw (long collar) **(2)**.

19

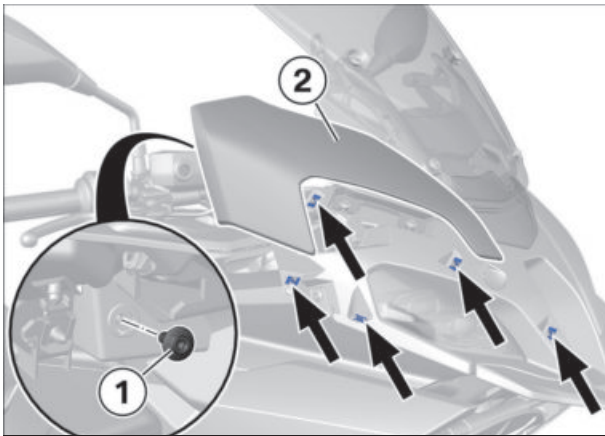

► **Installing top section of fairing, right**

- Secure fairing top section **(2)** in retaining clips **(arrows)** and install.
- Install bolt **(1)**.

20

► **Installing front right inner cover**

Requirement

Windscreen in upper position

ATTENTION

Use of hard or sharp-edged objects in proximity to component

Component damage

- Take care not to scratch components; cover or mask as necessary.
- Fit front right inner cover **(1)** and swing it inward engaging retaining clip **(2)** in recess **(3)**.

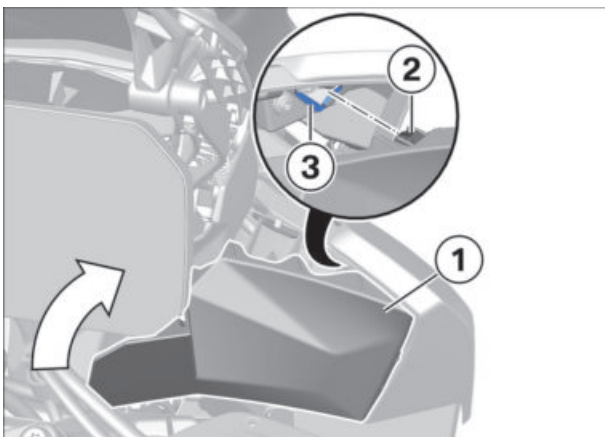

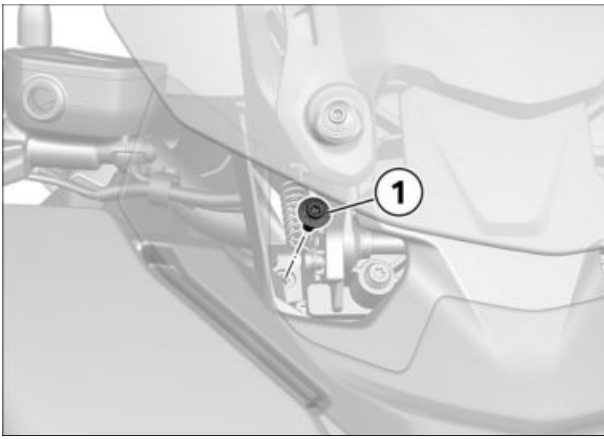

- Install bolt (1).

21

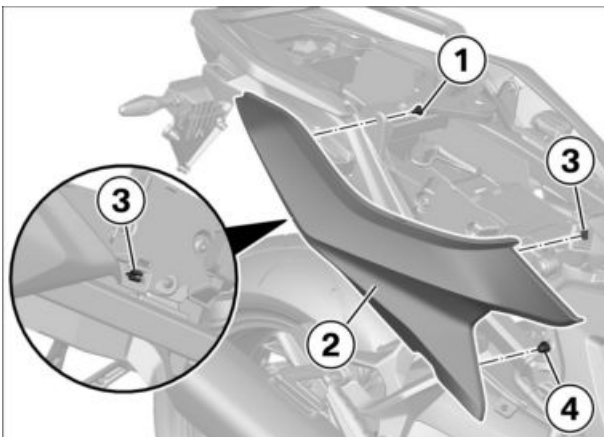

► Installing rear trim panel

- Install rear trim panel (2) and secure it in retaining clips (3) and on retaining pin (4).
- Install bolt (1).

22

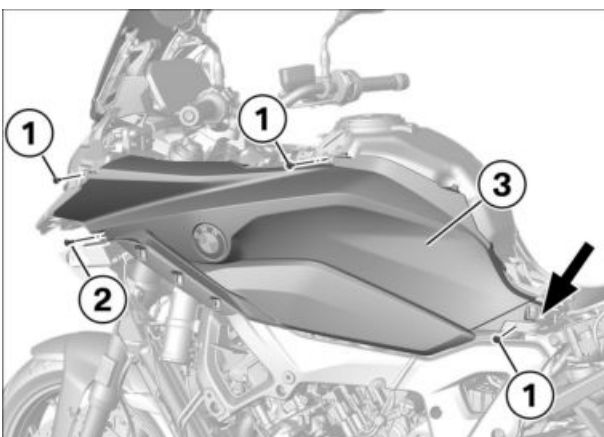

► Installing left cover of fuel tank

- Attach fuel tank cover (3) on left on fuel tank (arrow) and install.
- Install screws (short collar) (1) and screw (long collar) (2).

23

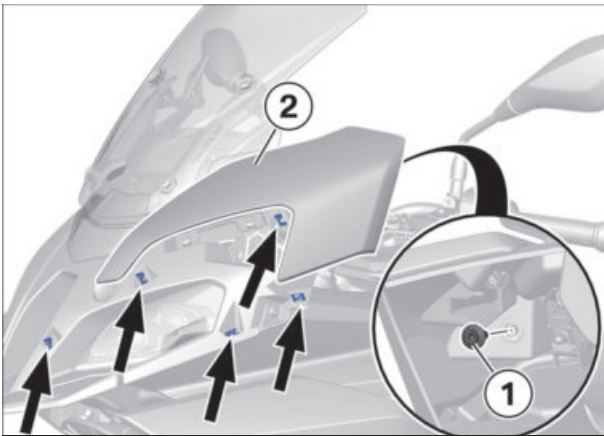

► Install the top section of fairing, left

- Secure fairing top section **(2)** in retaining clips **(arrows)** and install.
- Install bolt **(1)**.

24

► Installing front left inner cover

Requirement

Windscreen in upper position

ATTENTION

Use of hard or sharp-edged objects in proximity to component

Component damage

- Take care not to scratch components; cover or mask as necessary.

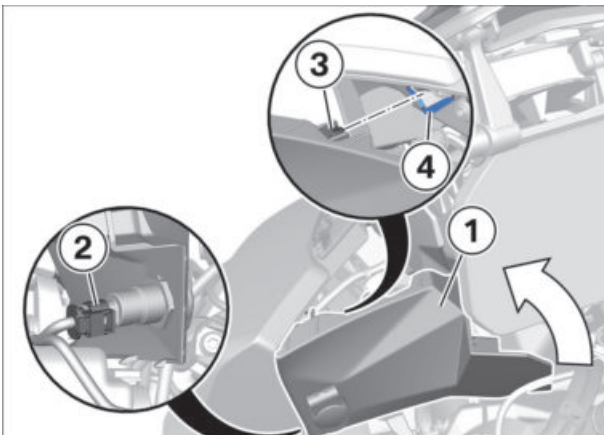

- Fit front left inner cover **(1)** and connect connector **(2)** for 12 V power socket.
- Swing inboard cover **(1)** inward engaging mounting clip **(3)** in recess **(4)**.

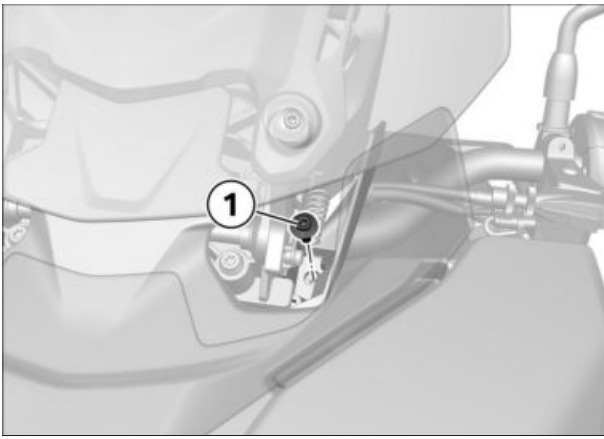

- Install bolt **(1)**.

25

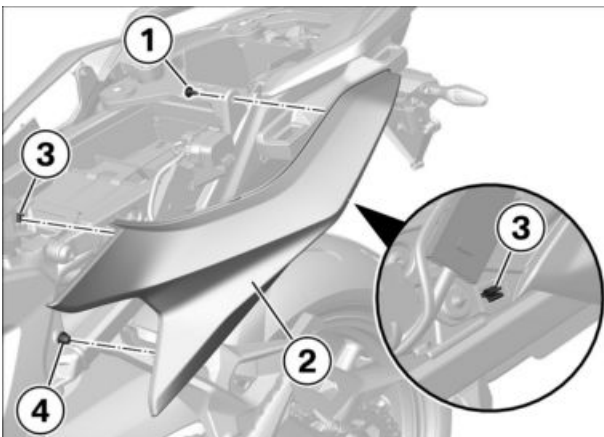

► Installing left rear trim panel

- Install rear trim panel **(2)** and secure it in retaining clips **(3)** and on retaining pin **(4)**.
- Install bolt **(1)**.

26

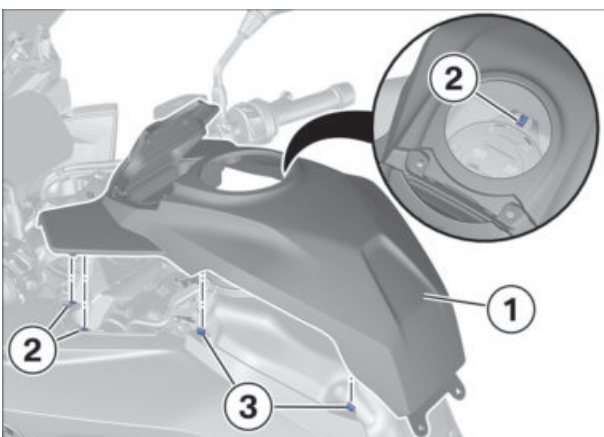

► Installing centre cover of fuel tank

- Install cover **(1)** securing it on left and right in retaining clips **(2)** and on retaining lugs **(3)**.

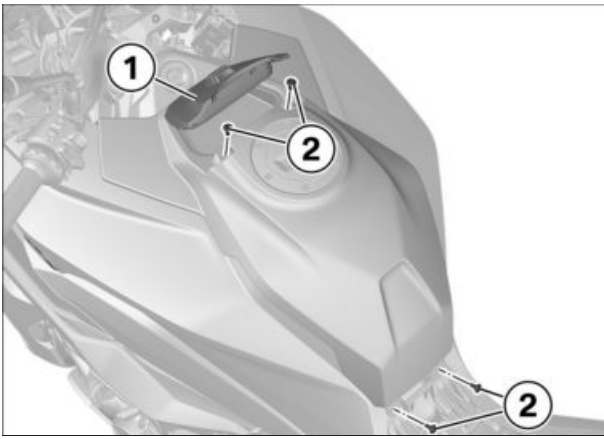

- Install screws **(2)**.
- Close storage compartment cover **(1)**.

27

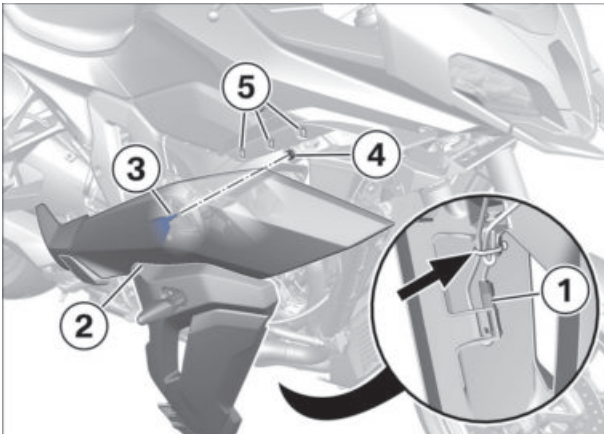

► Installing right side panel

- Connect plug connection **(1)** for right turn indicator and secure on fairing side panel **(2)**.
- Secure the cable strap **(arrow)**.
- Fit right fairing side panel **(2)** inserting guide pin **(3)** in rubber grommet **(4)**.
- Install fairing side panel **(2)** securing it in mounting clips **(5)**.

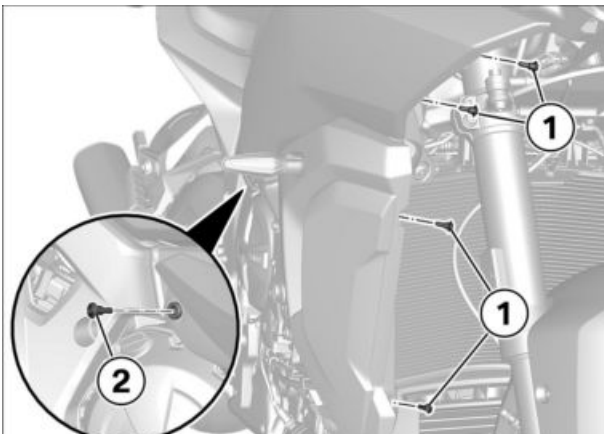

- Install screws (short collar) **(1)** and screw (long collar) **(2)**.

28

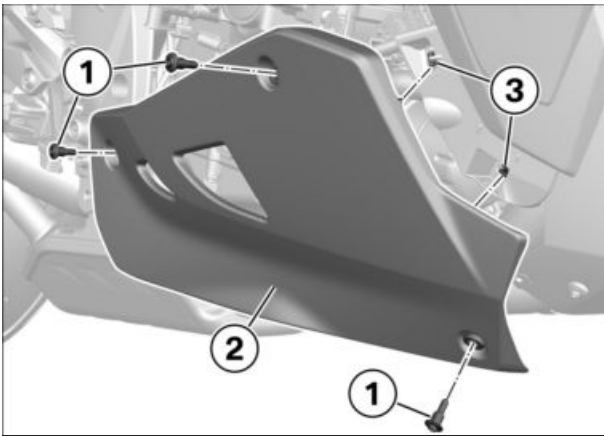

► Installing right engine spoiler

- Install engine spoiler (2) and secure in mounting clips (3).
- Install screws (1).



29

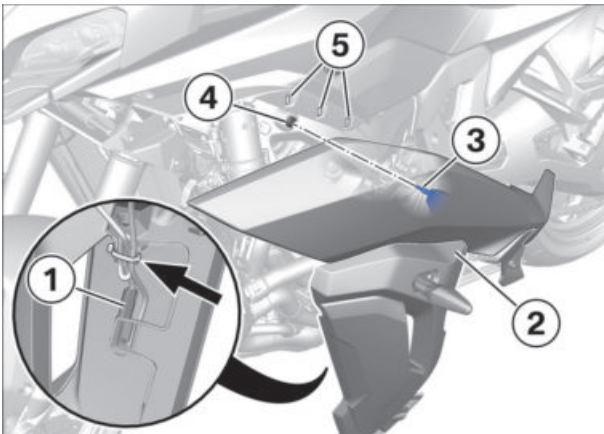

► Installing left side panel

- Connect plug connection (1) for left turn indicator and secure on fairing side panel (2).
- Secure the cable strap (arrow).
- Fit left fairing side panel (2) inserting guide pin (3) in rubber grommet (4).
- Install fairing side panel (2) securing it in mounting clips (5).

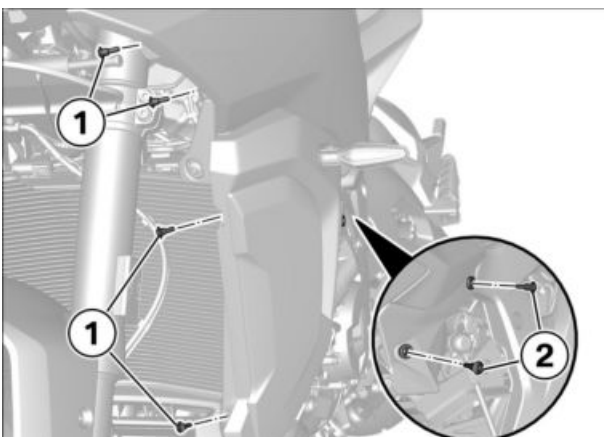

- Install screws (short collar) (1) and screws (long collar) (2).



30

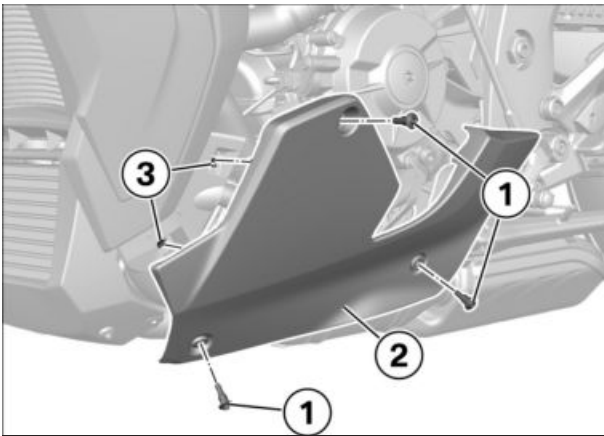

► Installing left engine spoiler

- Install engine spoiler (2) and secure in mounting clips (3).
- Install screws (1).

31

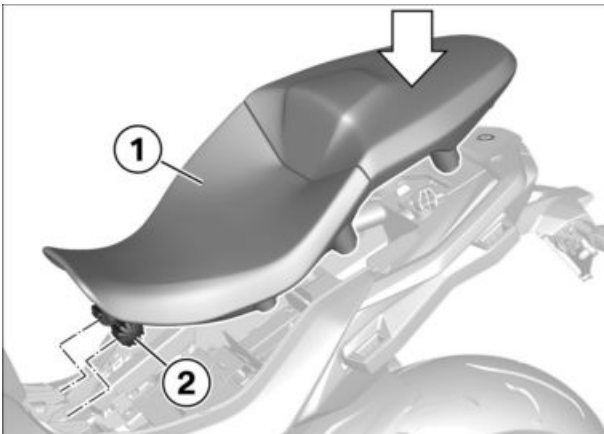

► Installing seat

- Insert seat (1) with buffers (2) in holder and install.
 - » Seat (1) engages with audible click.

32

► Final check of work performed

- Check the following:
 - The work as performed achieved the intended purpose.
 - All reservoirs and containers have been filled and all fluids and lubricants are at their correct levels.
 - All threaded fasteners released beforehand have been correctly retightened.
 - The fuel system is free of leaks.
 - The lights and signalling equipment are fully operational and the vehicle is roadworthy.
 - The brake pads of the front and rear brakes are bedded against the brake discs.

▷ Function test, engine start suppression

Check

- Set kill switch to "ON" position.

- Select neutral.
- Switch on the ignition.
 - » Neutral indicator light "N" lights up.
- Select a gear.
 - » Neutral indicator light "N" goes out.
- Press the starter button.
 - » Starter does **not** operate.
- Extend the side stand.
- Pull the clutch lever.
- Press the starter button.
 - » Starter does **not** operate.
- Retract the side stand.
- Press the starter button without releasing the clutch lever.
 - » Starter operates.

Result

Not all test steps completed successfully.

Measure

- Check the appropriate parts with the BMW Motorrad diagnostic system.

