



SIB 33 04 21 DRIVE CHAIN CONTACTS SWING ARM

2021-06-08

Model	Model Description	Production Date
K69	S 1000 XR	To May 31, 2021

SITUATION

Depending on the chassis and suspension adjustment, as well as vehicle load, the drive chain may make contact with the swing arm under certain conditions.

Figure 1: Location of damage on swing arm



CORRECTION

As of May 31, 2021, a chain-impact guard is installed at the factory.

PROCEDURE

For vehicles built before May 31, 2021, the chain impact guard can be retrofitted under warranty in the event of a complaint.

The swing arm should not be replaced due to damage from the chain, as described and pictured. This minimal impact mark does not affect the performance or operation of the swing arm.

The area to which the guard is applied must be thoroughly cleaned and free of dirt and chain grease. Please refer to the Figure 2 below for the correct attachment of the guard.

Figure 2: Installation location of chain guard

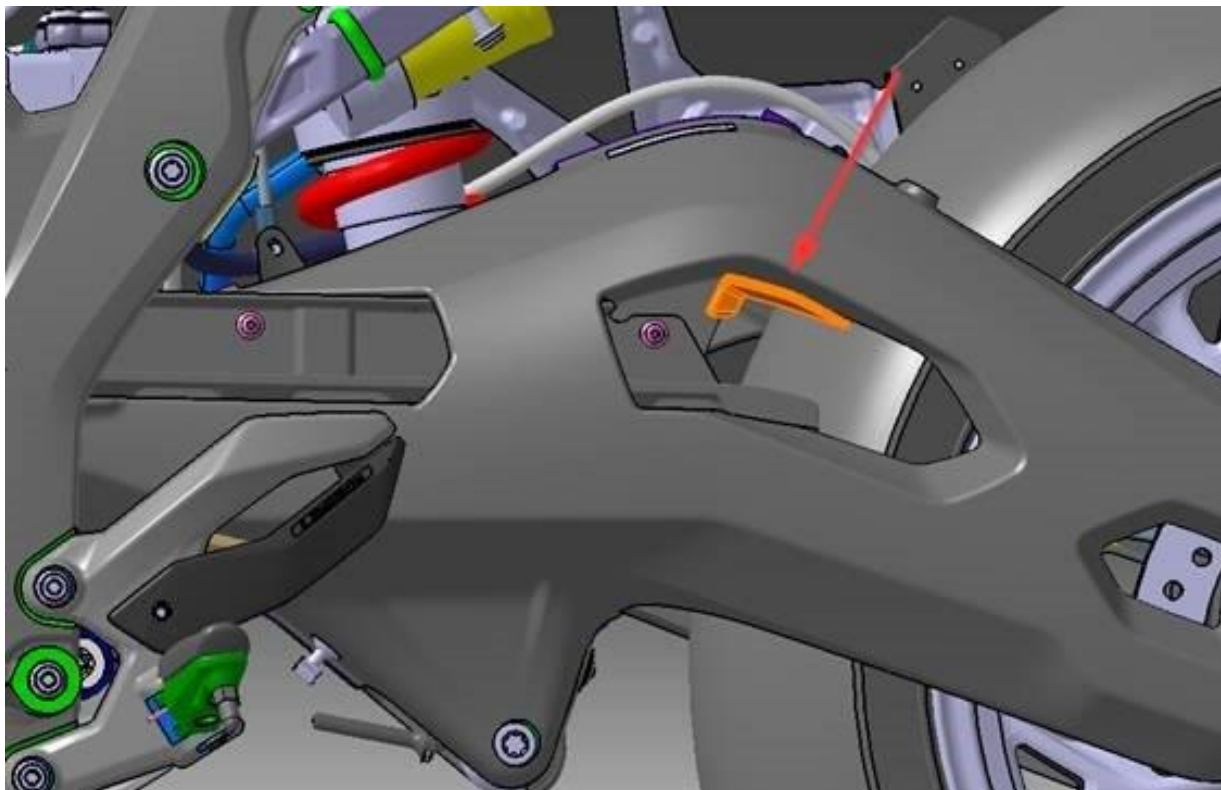

Please note, that a new impact guard must be installed any time the swing arm is replaced.

PARTS INFORMATION

Obtain and confirm the part numbers for your specific vehicle by entering the chassis number in ETK which takes into account specific equipment and/or options.

Additional parts like gaskets, hardware and chemicals may be required for the complete repair.

Part Number

33 35 1 696 865	Chain impact guard
-----------------	--------------------

Parts will be available end of June 2021.

WARRANTY INFORMATION

Covered under the terms of the BMW New Vehicle Limited Warranty for Motorcycles, if applicable.

Defect code

33 85 90 01 00	Retrofit chain impact guard
----------------	-----------------------------

Labor Operation

Copyright ©2021 MOTORRAD USA, a division of BMW of North America, LLC. All Rights Reserved	
--	--

33 85 001	Replacing chain slide rail	2 FRU
+33 85 501	Replacing chain slide rail	1 FRU

FRUs includes all repair procedures to complete the task with allowance for necessary ancillary tasks (e.g., visual inspection, lubrication, cleaning parts etc.) and administrative tasks.

QUESTIONS REGARDING THIS BULLETIN

Technical inquiries	Contact the BMW Technical Support Group via TSARA
Warranty inquiries	Submit an IDS ticket to the Warranty Department
Parts inquiries	Submit an IDS ticket to the Motorrad Parts Department

Supporting Materials

[picture_as_pdf 33 04 21 DRIVE CHAIN CONTACTS SWING ARM.pdf](#)

Service Information Bulletin

Rear Axle, Rear Drive

June 8, 2021

33 04 21

DRIVE CHAIN CONTACTS SWING ARM



MODEL

Model	Model Description	Production Date
K69	S 1000 XR	To May 31, 2021

SITUATION

Depending on the chassis and suspension adjustment, as well as vehicle load, the drive chain may make contact with the swing arm under certain conditions.

Figure 1: Location of damage on swing arm



CORRECTION

As of May 31, 2021, a chain-impact guard is installed at the factory.

PROCEDURE

For vehicles built before May 31, 2021, the chain impact guard can be retrofitted under warranty in the event of a complaint.

The swing arm should not be replaced due to damage from the chain, as described and pictured. This minimal impact mark does not affect the performance or operation of the swing arm.

The area to which the guard is applied must be thoroughly cleaned and free of dirt and chain grease. Please refer to the Figure 2 below for the correct attachment of the guard.

Figure 2: Installation location of chain guard

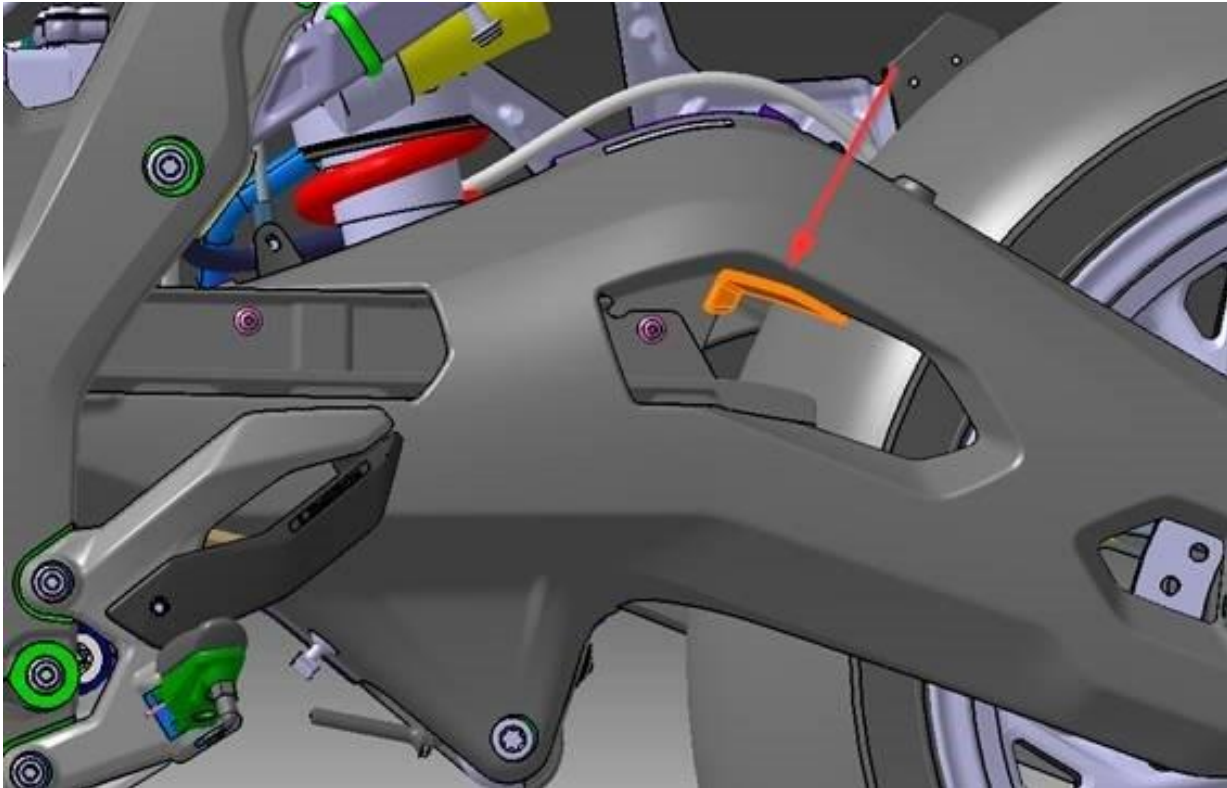

Please note, that a new impact guard must be installed any time the swing arm is replaced.

PARTS INFORMATION

Obtain and confirm the part numbers for your specific vehicle by entering the chassis number in ETK which takes into account specific equipment and/or options.

Additional parts like gaskets, hardware and chemicals may be required for the complete repair.

Part Number

33 35 1 696 865	Chain impact guard
-----------------	--------------------

Parts will be available end of June 2021.

WARRANTY INFORMATION

Covered under the terms of the BMW New Vehicle Limited Warranty for Motorcycles, if applicable.

© 2021, BMW of North America, LLC. The contents of this document are confidential and should not be shared with third parties for distribution. All pricing subject to change.

Defect code

33 85 90 01 00	Retrofit chain impact guard
----------------	-----------------------------

Labor Operation

33 85 001	Replacing chain slide rail	2 FRU
+33 85 501	Replacing chain slide rail	1 FRU

FRUs includes all repair procedures to complete the task with allowance for necessary ancillary tasks (e.g., visual inspection, lubrication, cleaning parts etc.) and administrative tasks.

QUESTIONS REGARDING THIS BULLETIN

Technical inquiries	Contact the BMW Technical Support Group via TSARA
Warranty inquiries	Submit an IDS ticket to the Warranty Department
Parts inquiries	Submit an IDS ticket to the Motorrad Parts Department