



Technical Service Bulletin

GROUP Fuel System	NUMBER 21-FL-003HG
DATE July, 2021	MODEL(S) G80 (DH)

SUBJECT: DTC U0109/U010900 FUEL PUMP CONTROL MODULE

Description: This TSB provides consolidated diagnosis and repair information, currently in the shop manual, to address DTC U0109 / U010900 related to a communication error with the Fuel Pump Control Module (FPCM).

DTC Information:

U0109 LOST COMMUNICATION WITH FUEL PUMP CONTROL MODULE

Applicable Vehicles: Certain 2017-2018MY G80 (DH) vehicles.

Parts Information:

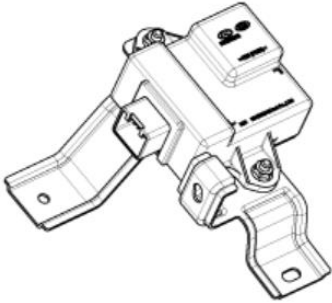
Parts Name	Part Number	Description	Note
Controller-Fuel Pump	33041-XXXXX		Refer to Electronic Parts Catalog for the applicable P/N based on VIN

Warranty Information:

Model	Op. Code	Operation	Op. Time	Causal Part	Nature Code	Cause Code
Genesis (DH)	33041R00	Fuel Pump Control Module Replacement	Refer to WEBLTS for current LTS time.	33041-XXXXX	I3T	ZZ3

NOTE 1: Normal warranty applies.

NOTE 2: Refer to Electronic Parts Catalog for full causal part number.

Inspection Procedure:

1. Connect GDS to the Data Link Connector (DLC).
2. If there are any FPCM DTC related codes, replace the FPCM.
3. Using a Voltmeter, check the Fuel Pressure Sensor (FPS) output voltage.

Specified Voltage: 5V



4. Using a Voltmeter, check the FPS output voltage at idle.

Specified Voltage: 1.4 – 3.2V



5. Test the fuel pressure at the fuel delivery line from the fuel tank.

Refer to the shop manual for complete test procedure:

Engine Control / Fuel System > Fuel Delivery System > Repair procedures

6. If FPCM out of specification, follow the Service Procedure in the next page to replace it.

Service Procedure:

1. Turn the ignition switch OFF and disconnect the vehicle's negative battery terminal.

NOTICE

- Be sure to record the radio presets prior to battery disconnection.

2. Remove the trunk rear transverse trim.
3. Fold the LH luggage side trim to access the FPCM.



4. To remove FPCM assembly from vehicle:

- Disconnect FPCM connector (A)
- Remove the mounting nuts (B)
- Remove FPCM (C)

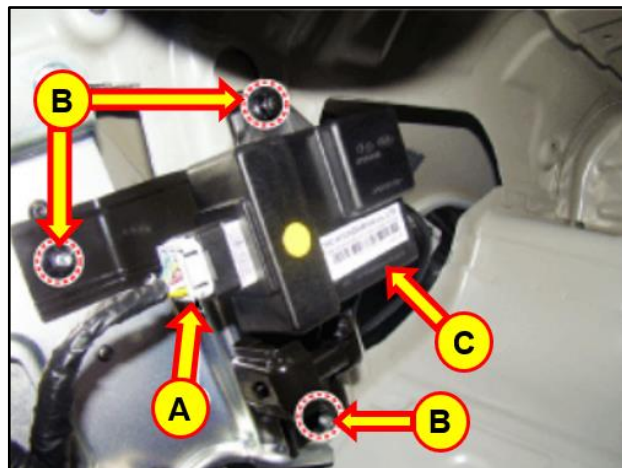

5. Reinstall all removed parts in reverse order of disassembly and reconnect the negative battery terminal.

NOTICE

- Reprogram the radio presets recorded from Service Procedure Step 1.

6. The service procedure is now complete.