

Approved Tires, Wheels and Spacers (73/20)



**Information**

The tire pressure applies only to the tire makes and types approved by Porsche, and is specified for cold tires (approx. 68° F/20°C). The tire pressures must never be lower than the specified values.



**Information**

Improper handling can damage the wheel surface.  
 Carry out tire removal and mounting using a bead holding-down device only.  
 Use a leather pad on the rim flange to support the valve insertion tool.  
 Only use the Porsche centering clamping set for balancing.  
 Do not use brushes to clean the wheels because brushes can cause deep scratches that cannot be removed by polishing.  
 Never use solvents or other chemical substances on tires.

Vehicle Types: **928, 928 S, 928 S4, 928 Club Sport, 928 GT, 928 GTS**

Model Year: **As of 1978 up to 1995**

Information: **Approved tires**



**Driving with different tires (mixed tires)**

- **Uncontrollable vehicle handling**
- ⇒ **Only use tires of the same make and type, with the same speed index and the same specification code (NO, N1, N2, ...) on a vehicle.**

Makes/Types:

Summer tire approvals		
Tire size	Tire make and type	Comments / Label value (link to EU database)

225/50 ZR16 (FA, RA)	Pirelli P Zero Asimmetrico N3	928 mod. 78 — 82 928 S mod 80 — 86 FA/RA: Label values currently not available
	Pirelli P Zero Rosso Asimmetrico N5	928 mod. 78 — 82 928 S mod 80 — 86 FA/RA: <a href="https://eprel.ec.europa.eu/qr/596144">https://eprel.ec.europa.eu/qr/596144</a>
	Continental ContiSport- Contact N2	928 mod. 78 — 82 928 S mod 80 — 86 FA/RA: Label values currently not available
	Michelin Pilot Exalto 2 NO	928 mod. 78 — 82 928 S mod 80 — 86 FA/RA: <a href="https://eprel.ec.europa.eu/qr/412732">https://eprel.ec.europa.eu/qr/412732</a>
	Pirelli P-Zero Trofeo R NO (UHP tires)	928 mod. 78 — 82 928 S mod 80 — 86 FA / RA: <a href="https://eprel.ec.europa.eu/qr/621931">https://eprel.ec.europa.eu/qr/621931</a>
	Pirelli P7 Cinturato N4	928 mod. 78 — 82 928 S mod 80 — 86 FA/RA: Label values currently not available
225/50 ZR16 (FA) 245/45 ZR16 (RA)	Continental ContiSport- Contact N2	928 S4 928 CS 928 GT 89 FA/RA: Label values currently not available
	Pirelli P Zero Rosso Asimmetrico N5	928 S4 928 CS 928 GT 89 FA: <a href="https://eprel.ec.europa.eu/qr/596144">https://eprel.ec.europa.eu/qr/596144</a> RA: <a href="https://eprel.ec.europa.eu/qr/596143">https://eprel.ec.europa.eu/qr/596143</a>
	Pirelli P-Zero Trofeo R NO (UHP tires)	928 S4 928 CS 928 GT 89 FA: <a href="https://eprel.ec.europa.eu/qr/621931">https://eprel.ec.europa.eu/qr/621931</a> RA: <a href="https://eprel.ec.europa.eu/qr/621932">https://eprel.ec.europa.eu/qr/621932</a>

	Pirelli P7 Cinturato N4	928 S4 928 CS 928 GT 89  FA/RA: Label values currently not available
225/45 ZR17 (FA) 255/40 ZR17 (RA)	Michelin Pilot Sport 2 N3	928 S4 928 CS 928 GT 89 928 GTS  FA: <a href="https://eprel.ec.europa.eu/qr/412319">https://eprel.ec.europa.eu/qr/412319</a> RA: <a href="https://eprel.ec.europa.eu/qr/412056">https://eprel.ec.europa.eu/qr/412056</a>
	Pirelli P Zero Rosso Asimmetrico N5	928 S4 928 CS 928 GT 89 928 GTS  FA: <a href="https://eprel.ec.europa.eu/qr/596141">https://eprel.ec.europa.eu/qr/596141</a> RA: <a href="https://eprel.ec.europa.eu/qr/596140">https://eprel.ec.europa.eu/qr/596140</a>
	Pirelli P-Zero Trofeo R NO (UHP tires)	928 S4 928 CS 928 GT 89 928 GTS  FA: <a href="https://eprel.ec.europa.eu/qr/621933">https://eprel.ec.europa.eu/qr/621933</a> RA: <a href="https://eprel.ec.europa.eu/qr/621934">https://eprel.ec.europa.eu/qr/621934</a>



**Information**

N... = Specification code of the tire, e.g. "N0", "N1", "N2" ... The complete "N ..." code of the tires in question must be shown on the tire sidewall near the tire type designation.

Instructions for correct mounting of the tires are also given on the tire sidewall. If there are no mounting instructions on the tire sidewall, the tire must be mounted so that the DOT marking is visible from the outside.



**Information**

If a tire is damaged and it is not possible to determine with absolute certainty that there is no ply damage - with all of its consequences - or if the tire was thermally and/or mechanically overloaded due to a loss of pressure or other prior damage, replace the tire in question for safety reasons.

Repairs to "V", "W", "Y" and "ZR" tires are not permissible, as well as the use of inner tubes in tubeless tires. Please inform your customers accordingly. It is advisable to mount winter tires at temperatures below **45° F/7°C**, because the driving characteristics of summer tires are reduced at low temperatures. Extremely low temperatures can cause permanent damage to summer tires.



**WARNING**

**Incorrect tire pressure**

- **Uncontrollable vehicle handling**
- ⇒ **Adjust the tire pressure according to specifications. Never allow the pressure to fall below the minimum pressure.**
- ⇒ **Check age of tires. Replace tires that are more than 6 years old.**
- ⇒ **Perform visual inspections.**
- ⇒ **Use new rubber valves at every tire change.**
- ⇒ **Use only tires approved by Porsche.**

Tire pressure:

	<b>16-inch wheels</b>	<b>17-inch wheels</b>
Front axle	2.5 bar (36 psi)	2.5 bar (36 psi)
Rear axle	3.0 bar (44 psi)	2.5 bar (36 psi)

Wheel  
Mounting:

The tightening torque for securing wheels and spacers is **130 Nm (96 ftlb.)**.

Sizes:

**Permissible summer tire and wheel sizes (RO = rim offset in mm)**

<b>Tires</b>	<b>Wheels</b>	<b>Notes</b>
225/50 ZR16 (FA, RA)	7Jx16, RO 65	928 mod. 78 — 82 928 S mod 80 — 86
225/50 ZR16 (FA) 245/45 ZR16 (RA)	7Jx16, RO 65 (FA) 8J x 16, RO 52.3 (RA)	928 S4, 928 CS, 928 GT 89
225/45 ZR17 (FA) 255/40 ZR17 (RA)	7.5Jx17, RO 65 (FA) 9J x 17, RO 55 (RA)	928 S4, 928 CS, 928 GT 89, 928 GTS

Further detailed information about permitted wheel and tire sizes as well as spacers that may be required can be found in the relevant parts certificates/manufacturer's certificates held by the Porsche partners.

Makes/types:

Winter tire approval			
Tire size	Tire make and type	Snow chain clearance (only without spacers)	Comments / Label value (link to EU database)
215/60 R15 90T M+S (FA, RA)  215/60 R15 93T M+S (FA, RA)	Continental TS 740	Yes Universal bar chain, quick assembly Part No.: 911 .361.909.00	928, 928 S, 928 S4 Area of application: Frequent highway trips FA/RA: Label values currently not available
	Goodyear Ultra Grip 3		928, 928 S, 928 S4 Area of application: Frequent highway trips FA/RA: Label values currently not available
	Semperit Top Grip		928, 928 S, 928 S4 Area of application: Frequent highway trips FA/RA: Label values currently not available
205/55 R16 88T M+S (FA, RA)	Bridgestone WT 04	Yes Universal bar chain, quick assembly Part No.: 911 .361.909.00	928, 928 S, 928 S4 Area of application: For all conditions FA/RA: Label values currently not available
	Continental TS 740		928, 928 S, 928 S4 Area of application: Frequent highway trips FA/RA: Label values currently not available
	Pirelli Winter 190		928, 928 S, 928 S4 Area of application: Frequent highway trips FA/RA: Label values currently not available
225/55 R16 92T M+S (FA, RA)	Pirelli Winter 190	Yes Universal bar chain, quick assembly Part No.: 911 .361.909.00 <b>No</b> snow-chain clearance on 8Jx16 wheels	928, 928 S, 928 S4 Area of application: For all conditions FA/RA: Label values currently not available
205/55 R16 94V M+S (FA, RA)	Pirelli W240 Sottozero Standard II N2	Yes	928, 928 S, 928 S4, 928 CS Up to model year 1988  FA/RA: <a href="https://eprel.ec.europa.eu/qr/596139">https://eprel.ec.europa.eu/qr/596139</a>

225/50 R16 96V M+S (FA, RA)	Pirelli W240 Sottozero Standard II N2	Yes	928, 928 S, 928 S4, 928 CS Up to model year 1988  FA/RA: <a href="https://eprel.ec.europa.eu/qr/596138">https://eprel.ec.europa.eu/qr/596138</a>
225/45 R17 94V M+S (FA, RA)	Pirelli Winter Sottozero 3 N2	Yes	928, 928 S, 928 S4, 928 CS Up to model year 1988  FA / RA: <a href="https://eprel.ec.europa.eu/qr/595708">https://eprel.ec.europa.eu/qr/595708</a>
225/45 R17 94V M+S (FA) 255/40 R17 98V M+S (RA)	Pirelli Winter Sottozero 3 N2	No	928, 928 S, 928 S4, 928 CS Up to model year 1988  FA: <a href="https://eprel.ec.europa.eu/qr/595708">https://eprel.ec.europa.eu/qr/595708</a> RA: <a href="https://eprel.ec.europa.eu/qr/595709">https://eprel.ec.europa.eu/qr/595709</a>
205/55 R16 94V M+S (FA) 225/50 R16 96V M+S (RA)	Pirelli W240 Sottozero Standard II N2	Yes	928, 928 S, 928 S4, 928 CS, 928 GT Mod. 89 – 93  FA: <a href="https://eprel.ec.europa.eu/qr/596139">https://eprel.ec.europa.eu/qr/596139</a> RA: <a href="https://eprel.ec.europa.eu/qr/596138">https://eprel.ec.europa.eu/qr/596138</a>
225/45 R17 94V M+S (FA, RA)	Pirelli Winter Sottozero 3 N2	Yes	928, 928 S, 928 S4, 928 CS, 928 GT Mod. 89 – 93  FA/RA: <a href="https://eprel.ec.europa.eu/qr/595708">https://eprel.ec.europa.eu/qr/595708</a>
225/45 R17 94V M+S (FA) 255/40 R17 98V M+S (RA)	Pirelli Winter Sottozero 3 N2	No	928, 928 S, 928 S4, 928 CS, 928 GT Mod. 89 – 93  FA: <a href="https://eprel.ec.europa.eu/qr/595708">https://eprel.ec.europa.eu/qr/595708</a> RA: <a href="https://eprel.ec.europa.eu/qr/595709">https://eprel.ec.europa.eu/qr/595709</a>
225/45 R17 94V M+S (FA, RA)	Pirelli Winter Sottozero 3 N2	Yes	928 GTS up to model year 1993  FA/RA: <a href="https://eprel.ec.europa.eu/qr/595708">https://eprel.ec.europa.eu/qr/595708</a>
225/45 R17 94V M+S (FA) 255/40 R17 98V M+S (RA)	Pirelli Winter Sottozero 3 N2	No	928 GTS up to model year 1993  FA: <a href="https://eprel.ec.europa.eu/qr/595708">https://eprel.ec.europa.eu/qr/595708</a> RA: <a href="https://eprel.ec.europa.eu/qr/595709">https://eprel.ec.europa.eu/qr/595709</a>
<b>Important:</b> Observe installation instructions from the chain manufacturer. For safety reasons, do not drive with snow chains at more than 50 km/h (30 mph) in Germany.			

Speed index: T = 190 km/h (118 mph), V = 240 km/h (150 mph)



### Information

N... = Specification code of the tire, e.g. "N0", "N1", "N2" ... The complete "N ..." code of the tires in question must be shown on the tire sidewall near the tire type designation.

Instructions for correct mounting of the tires are also given on the tire sidewall. If there are no mounting instructions on the tire sidewall, the tire must be mounted so that the DOT marking is visible from the outside.



### Information

If a tire is damaged and it is not possible to determine with absolute certainty that there is no ply damage - with all of its consequences - or if the tire was thermally and/or mechanically overloaded due to a loss of pressure or other prior damage, replace the tire in question for safety reasons.

Repairs to "V", "W", "Y" and "ZR" tires are not permissible, as well as the use of inner tubes in tubeless tires. Please inform your customers accordingly. It is advisable to mount winter tires at temperatures below **45° F/7°C**, because the driving characteristics of summer tires are reduced at low temperatures. Extremely low temperatures can cause permanent damage to summer tires.



### Incorrect tire pressure

- **Uncontrollable vehicle handling**
- ⇒ **Adjust the tire pressure according to specifications. Never allow the pressure to fall below the minimum pressure.**
- ⇒ **Check age of tires. Replace tires that are more than 6 years old.**
- ⇒ **Perform visual inspections.**
- ⇒ **Use new rubber valves at every tire change.**
- ⇒ **Use only tires approved by Porsche.**

Tire pressure:

	<b>16-inch wheels</b>	<b>17-inch wheels</b>
Front axle	2.5 bar (36 psi)	2.5 bar (36 psi)
Rear axle	3.0 bar (44 psi)	3.0 bar (44 psi)

Sizes: **Permissible winter tire and wheel sizes (RO = rim offset in mm)**

Tires	Wheels	Comments
215/60 R15 90T M+S (FA, RA) 215/60 R15 93T M+S (FA, RA)	7Jx15, RO 65	928, 928 S, 928 S4 up to and including MY 1985
205/55 R16 88T M+S (FA, RA)	7Jx16, RO 65 (FA) and 8Jx16, RO 52.3 (RA), or 7Jx16, RO 65 (FA, RA)	928, 928 S, 928 S4
225/55 R16 92T M+S (FA, RA)	7Jx16, RO 65 (FA) and 8Jx16, RO 52.3 (RA), or 7Jx16, RO 65 (FA, RA)	928, 928 S, 928 S4
205/55 R16 94V M+S (FA, RA)	7Jx16, RO 65 (FA, RA) 8J x 16, RO 52.3 (RA)	928, 928 S, 928 S4, 928 CS Up to model year 1988
205/55 R16 94V M+S (FA, RA)	7.5Jx16, RO 65	
225/50 R16 96V M+S (FA, RA)	7Jx16, RO 65	
225/50 R16 96V M+S (FA, RA)	7.5Jx16, RO 65 (FA) 8J x 16, RO 52.3 (RA)	
225/45 R17 94V M+S (FA, RA)	7.5Jx17, RO 65 (FA) 8Jx17, RO 52 (RA)	
225/45 R17 94V M+S (FA) 255/40 R17 98V M+S (RA)	7.5Jx17, RO 65 (FA) 9J x 17, RO 55 (RA)	
205/55 R16 94V M+S (FA, RA)	7Jx16, RO 65 (FA) 8J x 16, RO 52.3 (RA)	928, 928 S, 928 S4, 928 CS, 928 GT Mod. 89 – 93
225/50 R16 96V M+S (FA, RA)	7Jx16, RO 65 (FA) 8J x 16, RO 52.3 (RA)	
225/45 R17 94V M+S (FA, RA)	7.5Jx17, RO 65 (FA) 8Jx17, RO 52 (RA)	
225/45 R17 94V M+S (FA) 255/40 R17 98V M+S (RA)	7.5Jx17, RO 65 (FA) 9J x 17, RO 55 (RA)	
225/45 R17 94V M+S (FA, RA)	7.5Jx17, RO 65 (FA) 8Jx17, RO 52 (RA)	
225/45 R17 94V M+S (FA) 255/40 R17 98V M+S (RA)	7.5Jx17, RO 65 (FA) 9J x 17, RO 55 (RA)	928 GTS up to model year 1993
225/45 R17 94V M+S (FA, RA) 255/40 R17 98V M+S (RA)	7.5Jx17, RO 65 (FA) 9J x 17, RO 55 (RA)	

Wheels:

**Overview of Porsche wheels**

Identification on the inside/outside of the wheel disc:  
Wheel size, rim offset (RO) in mm, Part No. and Porsche logo

7J x 15 H2, RO 65  
928, 928 S up to MY 1985

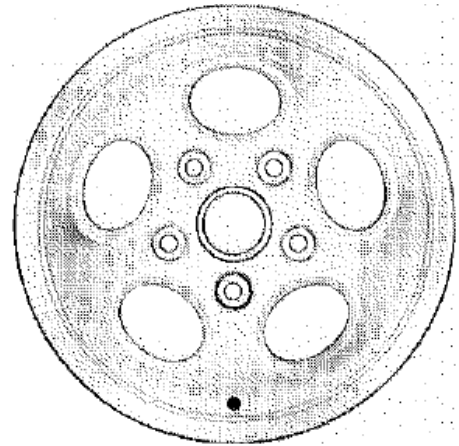

*Light alloy cast*

7J x 16 H2, RO 65  
8J x 16 H2, RO 52.3  
928, 928 S to MY 1985

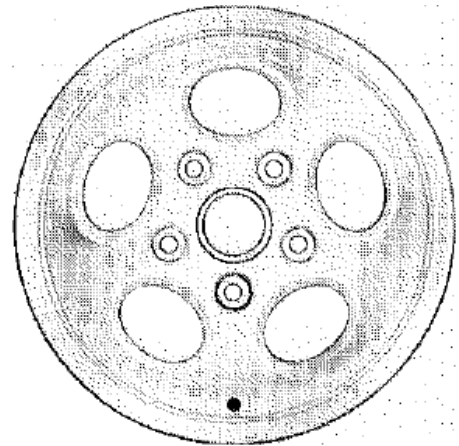

*Light alloy cast*

7J x 16 H2, RO 65  
8J x 16 H2, RO 52.3  
928, 928 S up to MY 1985,  
928 S, 928 S4 from MY 1986

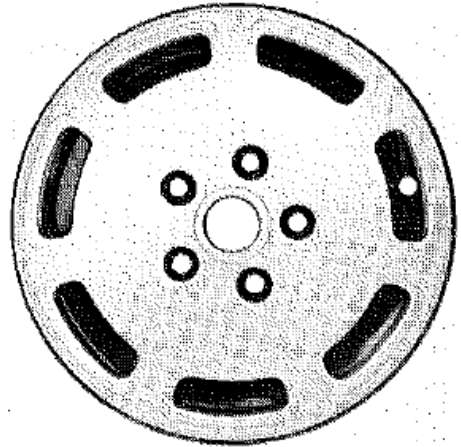

*Alloy, forged*

7J x 16 H2, RO 65  
928, 928 S up to MY 1985,  
928 S, 928 S4 from MY 1986

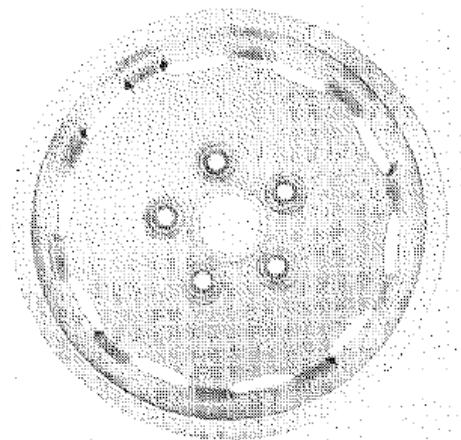

*Light alloy cast*

7J x 16 H2, RO 65  
8J x 16 H2, RO 52.3

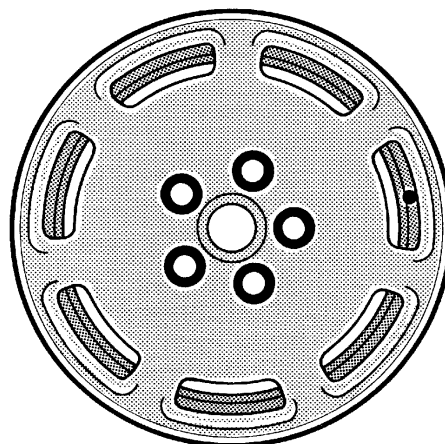

*Disc wheel, forged*

7.5J x 16 H2, RO 65  
8J x 16 H2, RO 60  
8J x 16 H2, RO 52.3  
9J x 16 H2, RO 52.3  
9J x 16 H2, RO 60

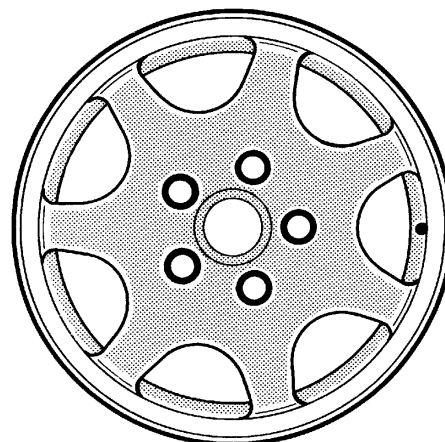

*Design 90 wheel*

7.5J x 17 AH, RO 65.0

8J x 17 AH, RO 52.0

9J x 17 AH, RO 55.0

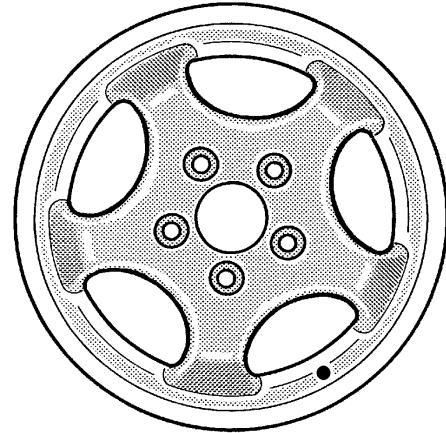

*17-inch Cup Design*

7.5J x 17 H2, RO 65.0

9J x 17 H2, RO 55.0

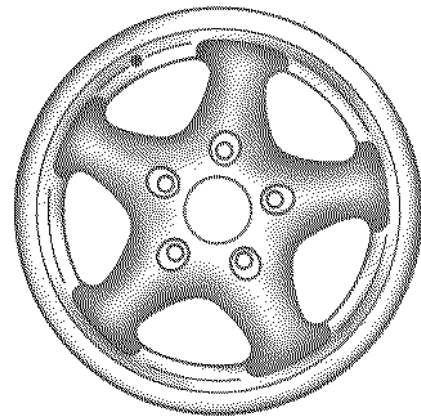

*Cup Design '93 wheel*

Wheel  
mounting:

The tightening torque for securing wheels and spacers is **130 Nm (96 ftlb.)**.

- Wheel Storage:
- Tires must be stored in a cool, dry and dark room with adequate ventilation.
  - Tires must never come into contact with fuel, oil, grease or chemicals.
  - Do not store summer tires in storage areas with ambient temperatures of less than 5° F (-15° C).
  - Complete wheel & tire assemblies can be stacked for storage; we recommend that you increase the tire pressure by approximately 6 psi (0.4 bar).
  - Optimum conditions for storage of the complete wheels are provided by the Original Porsche storage trolley, Part No. 000.044.000.38.
  - If the tires are not mounted on wheels, it is best to store them in a vertical position.

General  
Information:

- We recommend that you turn tires stored in this position every two weeks in order to prevent flat spots.
- Tires that are stacked in a horizontal position will become severely deformed and cannot be seated properly in the rim flange when they are mounted.
- Always use new valves when changing tires.
- Always observe any possible instructions concerning the rolling direction and/or specifying which side the tires must be mounted on.
- Coat the tire beads and humps with mounting lubricant before mounting the tire. This ensures that the tire beads will slide over the humps easily.
- In order to prevent the tire from turning on the wheel, avoid extreme driving maneuvers (acceleration and braking) during the first 100 to 200 miles with new or recently mounted tires.
- In order to optimize smoothness of rolling, it is appropriate - and necessary in individual cases - to mount the tire in a certain (favorable) position with respect to the wheel (matching).

**Matching (uncontrolled and controlled) is explained below: Uncontrolled matching:**

- Turning the tire on the wheel by 90° or 120° if necessary in order to achieve an acceptable value with regard to rolling smoothness (true running, imbalance and weight distribution of balance weights).

**Controlled matching:**

- With a balancing machine with matching program. In most cases, this produces an even better result with regard to the rolling smoothness (true running, imbalance and weight distribution of the balance weights) than can be achieved with uncontrolled matching.
- Maximum permissible radial runout and lateral runout of the wheels < 0.7 mm. Maximum permissible radial runout and lateral runout of the wheels with tires < 1.25 mm. Values < 1.50 mm -ideally approx. 0.5 mm - are desirable.
- The mounting pressure (seating pressure) of 58 psi/4.0 bar overpressure must not be exceeded before both tire beads are evenly seated on the rim flange.

**New Tires (Replacements):**

- If new tires are to be mounted or the tires of one axle are to be replaced, tires of the same make, type and with the same specification code must always be used on each of the two axles.
- If tires are replaced on one axle only, the different tread depth from that on the other axle can cause a noticeable change in the familiar handling.
- This is especially the case if new tires are mounted on the rear axle.
- This effect decreases with increasing tire mileage.

When replacing a tire on an axle, make sure that the tread depth of the new tire does not differ from that of the other tire on the same axle by more than 30 %.

Refer to WM 449503 for specific details of the vehicle you are working on.

- >The 2mm specification will be given here.
- > If there is none listed then the default is 30%.

**Repairs to Tires:**

- If a tire is damaged and it cannot be determined with absolute certainty that there is no ply damage - with all of its consequences - or if the tire was thermally or mechanically overloaded due to a loss of pressure or other prior damage, we recommend replacement of the tire in question for safety reasons.
- Repairs to "V", "W", "Y", and "ZR" tires are not permissible, as is the use of inner tubes in tubeless tires.

**Tire Aging:**

- Tires age due to chemical and physical processes, which can impair their function.
- Tires that are stored unused for an extended period harden and become brittle faster than tires that are in continual use.
- Hairline aging cracks can occur on older tires.
- On tires in continual use, the kneading action activates the plasticizer in the rubber and thereby prevents hardening and cracking.
- Therefore, attention should be paid not only to the tread depth but also to the age of the tire.
- Tires should not be older than 6 years.
- The age of the tire can be determined via the DOT code on the sidewall, which indicates the production date of the tire: e.g. DOT 2201 = 22nd week of 2001.

**Important Notice:** Technical Bulletins issued by Porsche Cars North America, Inc. are intended only for use by professional automotive technicians who have attended Porsche service training courses. They are written to inform those technicians of conditions that may occur on some Porsche vehicles, or to provide information that could assist in the proper servicing of a vehicle. Porsche special tools may be necessary in order to perform certain operations identified in these bulletins. Use of tools and procedures other than those Porsche recommends in these bulletins may be detrimental to the safe operation of your vehicle, and may endanger the people working on it. Properly trained Porsche technicians have the equipment, tools, safety instructions, and know-how to do the job properly and safely. Part numbers listed in these bulletins are for reference only. The work procedures updated electronically in the Porsche PIWIS diagnostic and testing device take precedence and, in the event of a discrepancy, the work procedures in the PIWIS Tester are the ones that must be followed.

© 2021 Porsche Cars North America, Inc.