

Technical Service Bulletin

Mazda North American Operations
Irvine, CA 92618-2922



Subject: WATER ENTRY FROM THE REAR DOOR	Bulletin No.: 09-020/21
	Last Issued : 07/07/2021

BULLETIN NOTES

This bulletin supersedes the previously issued bulletin(s) listed below: The changes are noted in Red.

Previous TSBs:	Date(s) Issued:
09-039/20	12/17/20

APPLICABLE MODEL(S)/VINS

2019-2021 Mazda3
2020-2021 CX-30

DESCRIPTION

Some vehicles may exhibit water leaking into the passenger compartment from the rear door through the bottom of the service hole behind the rear door trim during rain or when washing the vehicle.

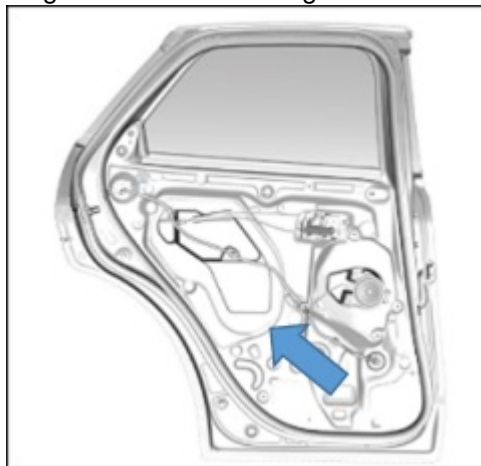

This is caused by one of the following:

- Since the material of the seal rubber is not resistant to surfactants, the rubber deteriorates when the vehicle is washed and allows water to penetrate into the seal rubber of the service hole cover.
- The lower tabs of the service hole cover may not have been completely engaged at the factory.

To eliminate this concern, the service-hole cover has been modified.

NOTE: It is a tentative change.

Customers having this concern should have their vehicle repaired using the following repair procedure.

Page 1 of 9

CONSUMER NOTICE: The information and instructions in this bulletin are intended for use by skilled technicians. Mazda technicians utilize the proper tools/ equipment and take training to correctly and safely maintain Mazda vehicles. These instructions should not be performed by "do-it-yourselfers." Customers should not assume this bulletin applies to their vehicle or that their vehicle will develop the described concern. To determine if the information applies, customers should contact their nearest authorized Mazda dealership. Mazda North American Operations reserves the right to alter the specifications and contents of this bulletin without obligation or advance notice. All rights reserved. No part of this bulletin may be reproduced in any form or by any means, electronic or mechanical--including photocopying and recording and the use of any kind of information storage and retrieval system ---without permission in writing.

REPAIR PROCEDURE

1. Verify customer concern.
2. Remove the service hole covers from the REAR DOOR LATCH AND LOCK ACTUATOR REMOVAL/INSTALLATION procedure on MGSS and replace with new ones, using the following steps when installing.

- Mazda3 (REAR DOOR LATCH AND LOCK ACTUATOR REMOVAL/INSTALLATION)
- CX-30 (REAR DOOR LATCH AND LOCK ACTUATOR REMOVAL/INSTALLATION)

There are 2 types of new covers: modified service-hole covers and non-modified ones. Images are for the left side door. Mazda3

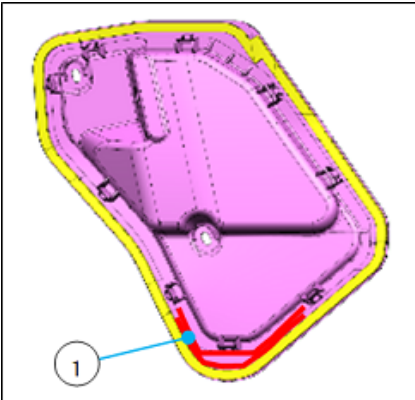

Modified service-hole cover with seal material (1)
B0J8-72-973 / B0J8-73-973

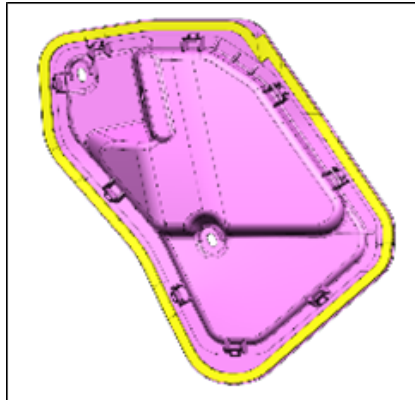

Non-modified service-hole covers
BCJH-72-973E / BCJH-73-973E
BDTS-72-973E / BDTS-73-973E

CX-30

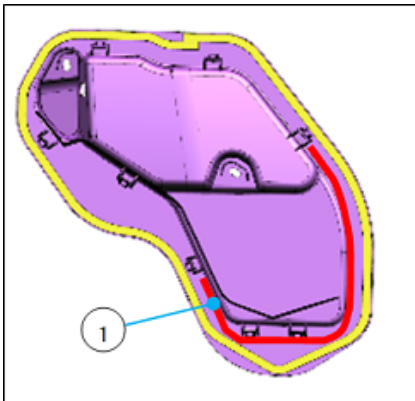

Modified service-hole cover
with a seal material (1)
DFR5-72-973 / DFR5-73-973

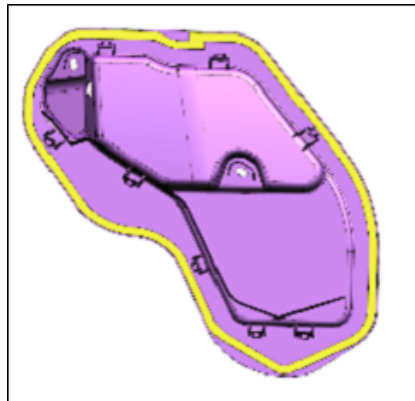

Non-modified service-hole cover
DFR5-72-973 / DFR5-73-973
DGH9-72-973 / DGH9-73-973

CONSUMER NOTICE: The information and instructions in this bulletin are intended for use by skilled technicians. Mazda technicians utilize the proper tools/ equipment and take training to correctly and safely maintain Mazda vehicles. These instructions should not be performed by "do-it-yourselfers." Customers should not assume this bulletin applies to their vehicle or that their vehicle will develop the described concern. To determine if the information applies, customers should contact their nearest authorized Mazda dealership. Mazda North American Operations reserves the right to alter the specifications and contents of this bulletin without obligation or advance notice. All rights reserved. No part of this bulletin may be reproduced in any form or by any means, electronic or mechanical--including photocopying and recording and the use of any kind of information storage and retrieval system ---without permission in writing.

Repair procedure depends on the type of the obtained part.

- Modified service-hole cover with seal materials: Replace the service-hole cover with a modified one.
- Non-modified service-hole covers: Apply butyl tapes as follows.

NOTE: Butyl tape is applied to the service hole covers to help prevent the water from seeping through. The product to use is 3M - 08610 Round Ribbon Sealer. Contact the local 3M distributor and order (1) roll. One roll will repair 7 vehicles.

a. Cut butyl tape to the following sizes:

NOTE: Use butyl tape with a width=1/4 in (6.4mm) and thickness=1/8 in (3.2mm).

Mazda3	CX-30
TAPE-1: 6 in (150mm) x 1pcs.	TAPE-1: 8 in (200mm) x 1pc.
TAPE-2: 4 in (100mm) x 1pcs.	TAPE-2: 4-3/4 in (120mm) x 1pc.

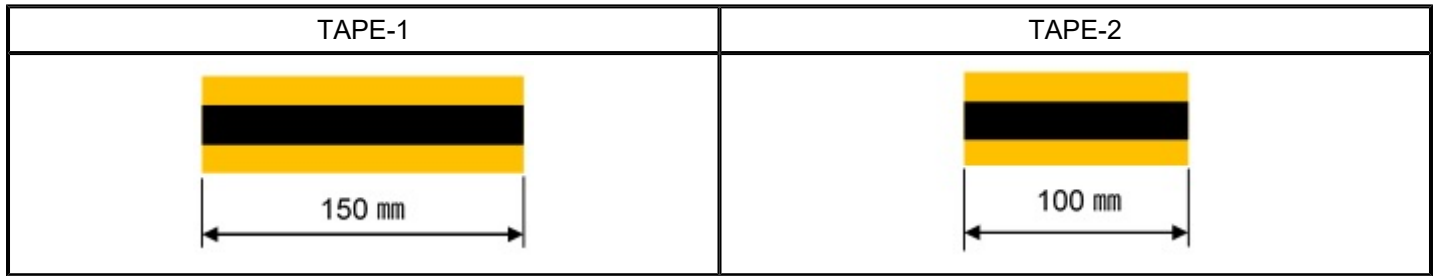

CX-30

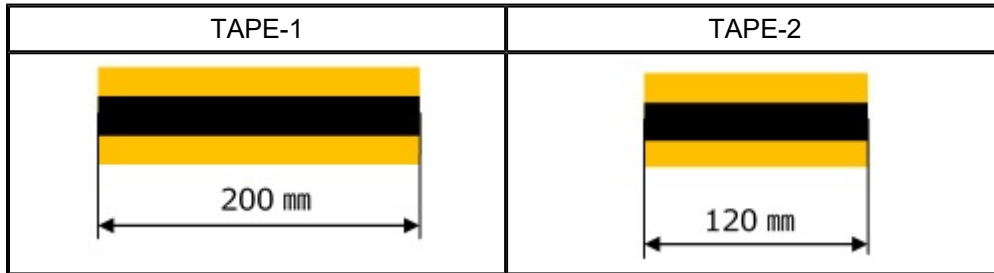

CONSUMER NOTICE: The information and instructions in this bulletin are intended for use by skilled technicians. Mazda technicians utilize the proper tools/ equipment and take training to correctly and safely maintain Mazda vehicles. These instructions should not be performed by "do-it-yourselfers." Customers should not assume this bulletin applies to their vehicle or that their vehicle will develop the described concern. To determine if the information applies, customers should contact their nearest authorized Mazda dealership. Mazda North American Operations reserves the right to alter the specifications and contents of this bulletin without obligation or advance notice. All rights reserved. No part of this bulletin may be reproduced in any form or by any means, electronic or mechanical--including photocopying and recording and the use of any kind of information storage and retrieval system ---without permission in writing.

b. Remove any oil/grease from the area highlighted in green (images shown are the left side door).
Mazda3

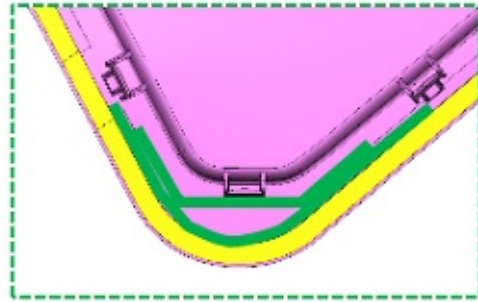
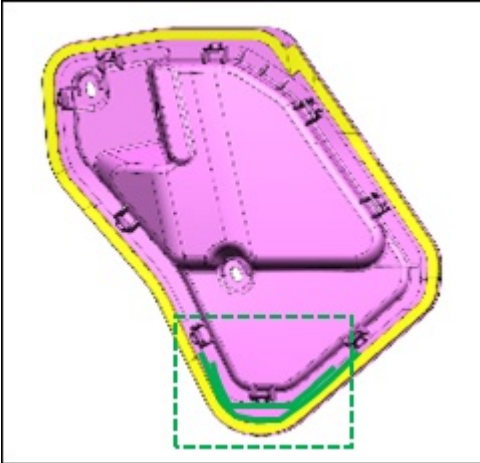

CX-30

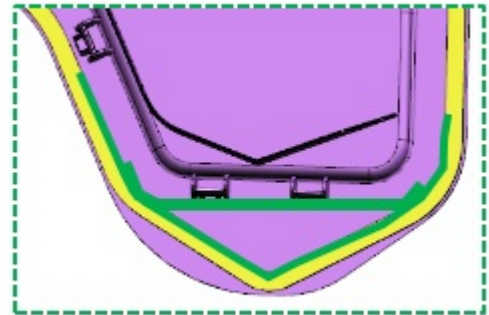
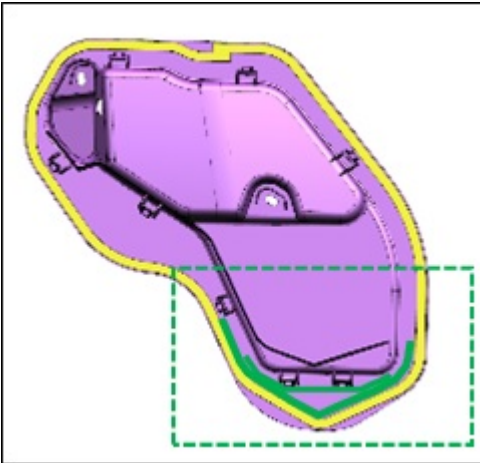

CONSUMER NOTICE: The information and instructions in this bulletin are intended for use by skilled technicians. Mazda technicians utilize the proper tools/ equipment and take training to correctly and safely maintain Mazda vehicles. These instructions should not be performed by "do-it-yourselfers." Customers should not assume this bulletin applies to their vehicle or that their vehicle will develop the described concern. To determine if the information applies, customers should contact their nearest authorized Mazda dealership. Mazda North American Operations reserves the right to alter the specifications and contents of this bulletin without obligation or advance notice. All rights reserved. No part of this bulletin may be reproduced in any form or by any means, electronic or mechanical---including photocopying and recording and the use of any kind of information storage and retrieval system ---without permission in writing.

c. Apply TAPE-1 (6) as per the green line below along with the seal rubber (5).

NOTE:

- Using water on your hands will make working with the butyl tape easier as the tape will not stick to hands with water on them.
- Be careful not to apply TAPE-1 to the front part of the tabs as it is difficult to apply TAPE-1 near the tabs.

1) Start applying TAPE-1 (6) at the edge (1) of the tab.

2) Using the release paper (4), press the tape hard (2) to fill the gap (3) between TAPE-1 (6) and the seal rubber (5) / service hole cover (7).

Mazda3

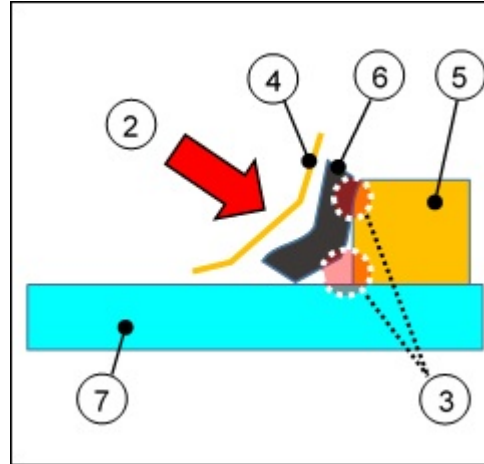
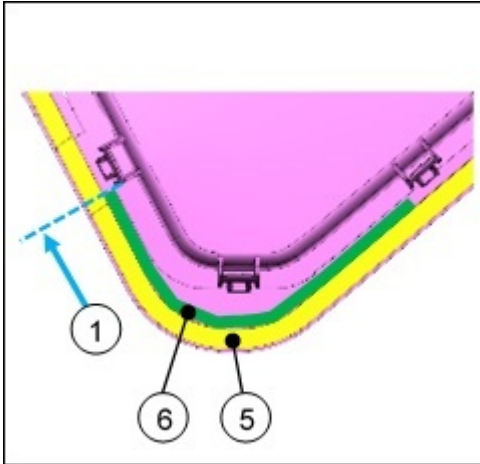

CX-30

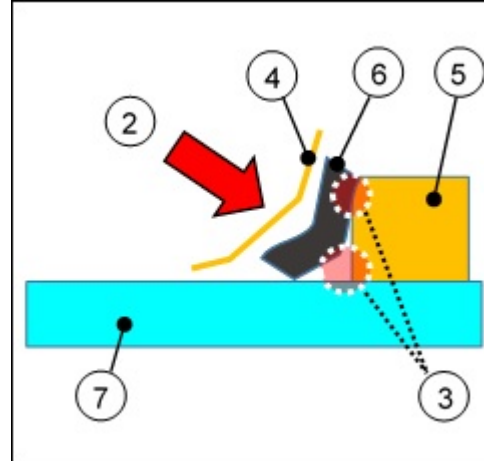
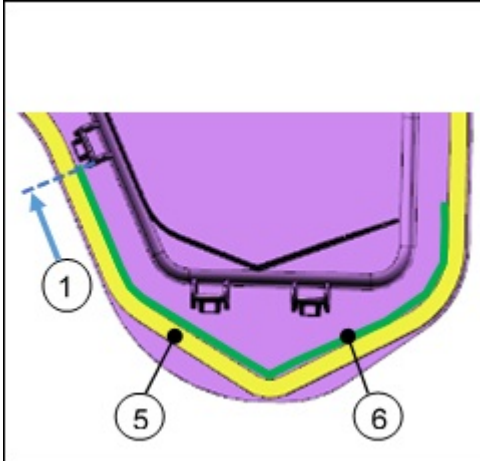

CONSUMER NOTICE: The information and instructions in this bulletin are intended for use by skilled technicians. Mazda technicians utilize the proper tools/ equipment and take training to correctly and safely maintain Mazda vehicles. These instructions should not be performed by "do-it-yourselfers." Customers should not assume this bulletin applies to their vehicle or that their vehicle will develop the described concern. To determine if the information applies, customers should contact their nearest authorized Mazda dealership. Mazda North American Operations reserves the right to alter the specifications and contents of this bulletin without obligation or advance notice. All rights reserved. No part of this bulletin may be reproduced in any form or by any means, electronic or mechanical---including photocopying and recording and the use of any kind of information storage and retrieval system ---without permission in writing.

CORRECT (image is of CX-30)

The butyl tape (2) IS sticking up at or above the height of seal rubber (1).

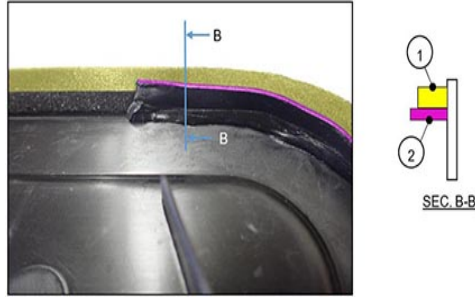

d. Apply TAPE-2 as per the blue line below.

NOTE:

- DO NOT fill area (1) to avoid blocking the drain hole on the door panel.
- Apply TAPE-2 along the bottom edge of the ribs (2) of the tab.
- Make sure TAPE-1 and TAPE-2 make good contact with each other when they overlap.

Mazda3

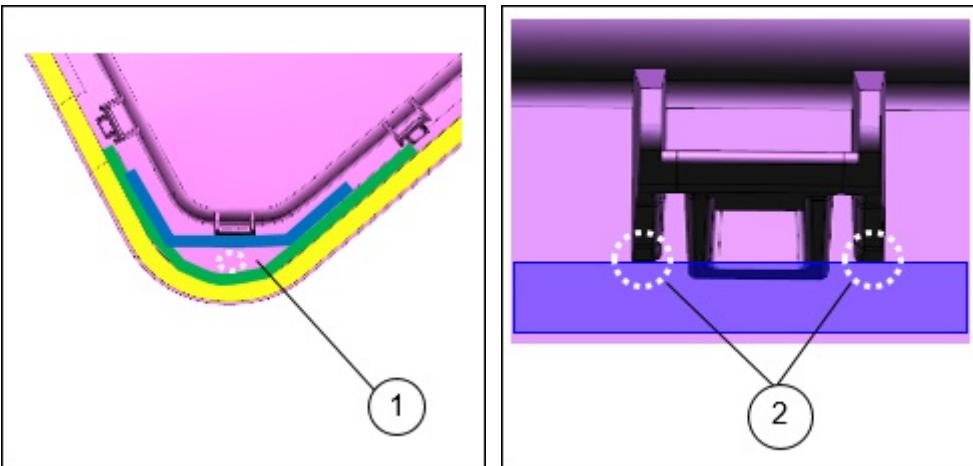

CONSUMER NOTICE: The information and instructions in this bulletin are intended for use by skilled technicians. Mazda technicians utilize the proper tools/ equipment and take training to correctly and safely maintain Mazda vehicles. These instructions should not be performed by "do-it-yourselfers." Customers should not assume this bulletin applies to their vehicle or that their vehicle will develop the described concern. To determine if the information applies, customers should contact their nearest authorized Mazda dealership. Mazda North American Operations reserves the right to alter the specifications and contents of this bulletin without obligation or advance notice. All rights reserved. No part of this bulletin may be reproduced in any form or by any means, electronic or mechanical---including photocopying and recording and the use of any kind of information storage and retrieval system ---without permission in writing.

CX-30

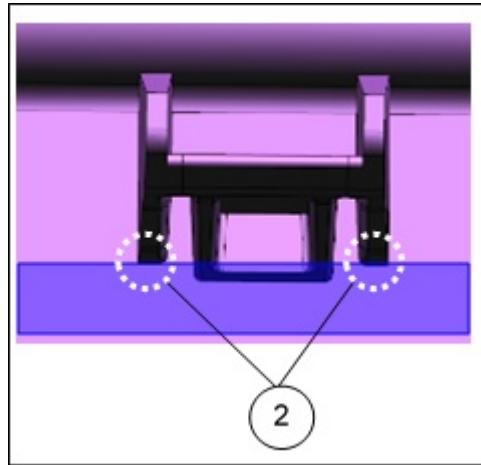
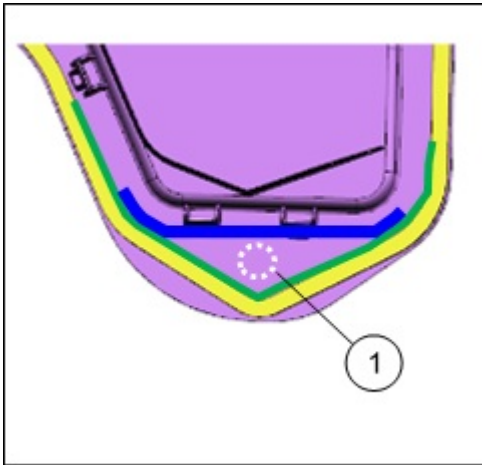

Examples of NOT CORRECT placement of tapes (image is of CX-30)

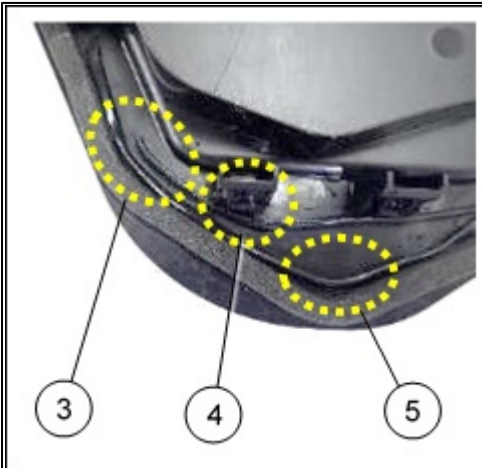

- (3) TAPE-2 does not adhere to TAPE-1.
- (4) TAPE-2 is away from the tab.
- (5) TAPE-1 does not adhere to the seal rubber.

CONSUMER NOTICE: The information and instructions in this bulletin are intended for use by skilled technicians. Mazda technicians utilize the proper tools/ equipment and take training to correctly and safely maintain Mazda vehicles. These instructions should not be performed by "do-it-yourselfers." Customers should not assume this bulletin applies to their vehicle or that their vehicle will develop the described concern. To determine if the information applies, customers should contact their nearest authorized Mazda dealership. Mazda North American Operations reserves the right to alter the specifications and contents of this bulletin without obligation or advance notice. All rights reserved. No part of this bulletin may be reproduced in any form or by any means, electronic or mechanical---including photocopying and recording and the use of any kind of information storage and retrieval system ---without permission in writing.

e. Press (1) the release paper (2) against TAPE-2 (5) to adhere the butyl tape to the service hole cover (4) [seal rubber (3)].

Mazda3

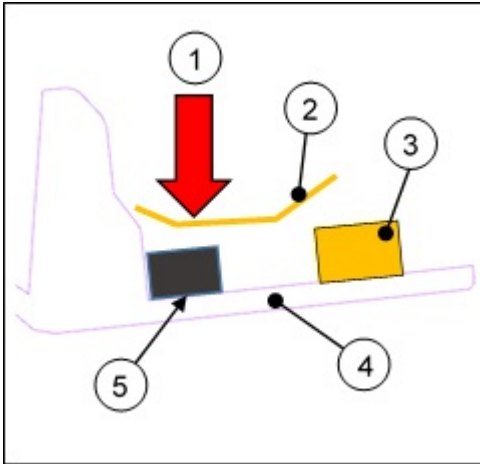

CX-30

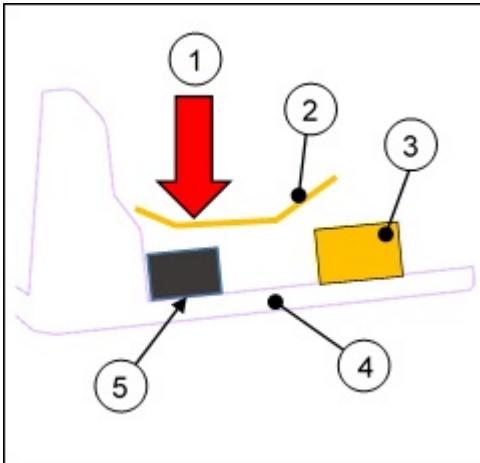

f. Repeat these steps on the other side.

3. Verify repair.

CONSUMER NOTICE: The information and instructions in this bulletin are intended for use by skilled technicians. Mazda technicians utilize the proper tools/ equipment and take training to correctly and safely maintain Mazda vehicles. These instructions should not be performed by "do-it-yourselfers." Customers should not assume this bulletin applies to their vehicle or that their vehicle will develop the described concern. To determine if the information applies, customers should contact their nearest authorized Mazda dealership. Mazda North American Operations reserves the right to alter the specifications and contents of this bulletin without obligation or advance notice. All rights reserved. No part of this bulletin may be reproduced in any form or by any means, electronic or mechanical---including photocopying and recording and the use of any kind of information storage and retrieval system ---without permission in writing.

PARTS INFORMATION

Parts Number	Description	Qty.	Notes
B0J8-72-973 or BCJH-72-973E	Cover (RR, R), Hole-Door In	1	Mazda3 (Japan built)
B0J8-73-973 or BCJH-73-973E	Cover (RR, L), Hole-Door In	1	Mazda3 (Japan built)
BDTS-72-973E	Cover (RR, R), Hole-Door In	1	Mazda3 (Mexico built)
BDTS-73-973E	Cover (RR, L), Hole-Door In	1	Mazda3 (Mexico built)
DGH9-72-973	Cover (RR, R), Hole-Door In	1	CX-30
DGH9-73-973	Cover (RR, L), Hole-Door In	1	CX-30

WARRANTY INFORMATION**NOTE:**

- This warranty information applies only to verified customer complaints on vehicles eligible for warranty repair.
- This repair will be covered under Mazda's New Vehicle Limited Warranty term.
- Additional diagnostic time cannot be claimed for this repair.

Warranty Type	A
Symptom Code	77
Damage Code	9B
Part Number Main Cause	****-72-973* or ****-73-973*
Quantity	1
Operation Number / Labor Hours:	XXS6KARX / 0.4 Hrs. (when the obtained parts have seal materials applied for both sides)
	XXS6KBRX / 0.6 Hrs. (when the obtained parts has one side with seal materials applied and the other side does not)
	XXS6KXRX / 0.8 Hrs. (when the obtained parts required butyl tape application for both sides)

NOTE: Claim 1/7 of the roll per repair as a sublet Z9 for \$5.00.

CONSUMER NOTICE: The information and instructions in this bulletin are intended for use by skilled technicians. Mazda technicians utilize the proper tools/ equipment and take training to correctly and safely maintain Mazda vehicles. These instructions should not be performed by "do-it-yourselfers." Customers should not assume this bulletin applies to their vehicle or that their vehicle will develop the described concern. To determine if the information applies, customers should contact their nearest authorized Mazda dealership. Mazda North American Operations reserves the right to alter the specifications and contents of this bulletin without obligation or advance notice. All rights reserved. No part of this bulletin may be reproduced in any form or by any means, electronic or mechanical--including photocopying and recording and the use of any kind of information storage and retrieval system ---without permission in writing.