

Manufacturer's Certificate

Freigabe/Approval

28/21 ENU 4400

4

Approved: Tires, Wheels and Spacers (28/21)

Vehicle Types **944, 944 S, 944 S2, 944 Turbo**

Model Year: **As of 1987 up to 1991**

Information: **Tire approval**



Driving with different tires (mixed tires)

- **Uncontrollable vehicle handling**

⇒ **Only use tires of the same make and type, with the same speed index and the same specification code (NO, N1, N2, ...) on a vehicle.**

Sizes:

Summer tire approval for 944, 944 S and 944 Turbo (engine power 162 kW), each with standard or sports chassis, as well as 944 S2 with standard chassis		
Tire size	Wheels	Notes
195/65 R15 (FA, RA)	7Jx15, RO 52.3	not for 944 S2 and 944 Turbo
215/60 R15 (FA, RA)	7Jx15, RO 52.3	not for 944 S2 and 944 Turbo
205/55 R16 (FA) 225/50 R 16 (RA)	7Jx16, RO 52.3/55 (FA) 8Jx16, RO 52.3/52 (RA)	Anti-roll bar required on rear axle
225/45 ZR 17 (FA) 255/40 ZR 17 (RA)	7.5Jx17, RO 65 (RA) 9Jx17, RO 55 (RA)	Anti-roll bar required on rear axle; The wing seam on the front and rear axle must be flared; only for vehicles with sports chassis (exception: 944 S2 also with standard chassis) When converting to 17-inch, the rubber mounts must be replaced with 951.341.023.01 and the eccentric pins with 951.341.431.01. Snow chains cannot be installed
225/45 ZR 17 (FA)	8Jx17, RO 52 (FA)	not for cabriolet vehicles; Anti-roll bar required on rear axle;

255/40 ZR 17 (RA)	9.5Jx17, RO 68 (RA)	<p>The wing seam on the front and rear axle must be flared; only for vehicles with sports chassis (exception: 944 S2 also with standard chassis);</p> <p>When converting to 17-inch, the rubber mounts must be replaced with 951.341.023.01 and the eccentric pins with 951.341.431.01.</p> <p>Snow chains cannot be installed</p>
-------------------	---------------------	---

Summer tire approval for 944 Turbo (engine power 184 kW) and 944 S2 with chassis R01		
Tire size	Wheels	Comments
225/45 ZR 17 (FA) 255/40 ZR 17 (RA)	8Jx17, RO 52 (FA) 9.5Jx17, RO 68 (RA)	<p>The wing seam on the rear axle must be flared; snow chains cannot be installed</p> <p>9.5Jx17, RO 68: Only with a spacer ring of 17 mm per wheel on the rear axle, Part No 951.331.611.02 or 993.361.617.00. The spacer ring must be removed when mounting the spare wheel.</p>
225/50 ZR 16 (FA) 245/45 ZR 16 (RA)	7 J x 16, RO 65 (FA) 9 J x 16, RO 60 (RA)	The wing seam on the rear axle must be flared; snow chains cannot be installed
	7.5 J x 16, RO 65 (FA) 9 J x 16, RO 52.3 (RA)	The wing seam on the rear axle must be flared; snow chains cannot be installed

225/45 ZR 17 (FA) 255/40 ZR 17 (RA)	7.5Jx17, RO 65 (RA) 9Jx17, RO 55 (RA)	The wing seam on the rear axle must be flared; snow chains cannot be installed When converting to 17-inch, the rubber mounts must be replaced with 951.341.023.01 and the eccentric pins with 951.341.431.01.
	8Jx17, RO 52 (FA) 9.5Jx17, RO 68 (RA)	The wing seam on the rear axle must be flared; snow chains cannot be installed When converting to 17-inch, the rubber mounts must be replaced with 951.341.023.01 and the eccentric pins with 951.341.431.01. 9.5Jx17 RO 68: Only permitted with a spacer ring of 17 mm per wheel on the rear axle; Part No. 951.331.611.02 or 993.361.617.00 The spacer ring must be removed when installing the mounting the spare wheel not for cabriolet vehicles

Winter tire approvals for the Porsche series vehicles of the 944, 944 S and 944 Turbo (engine power 162 kW), each with standard or sport chassis, as well as 944 S2 with standard chassis		
Tire size	Wheels	Comments
195/65 R15 (FA, RA)	7Jx15, RO 52.3	not for 944 S2 and 944 Turbo
215/60 R15 (FA, RA)	7Jx15, RO 52.3	not for 944 S2 and 944 Turbo

205/55 R16 M+S (FA, RA)	7Jx16, RO 52.3/55 (FA) 8 J x 16, RO 52.3/52 (RA)	Anti-roll bar required on rear axle
205/55 R16 (FA) 225/50 R 16 (RA)	7Jx16, RO 52.3/55 (FA) 8 J x 16, RO 52.3/52 (RA)	
205/50 R17 M+S (FA) 225/45 R17 M+S (RA)	7.5Jx17, RO 65 (FA) 8Jx17, RO 52 (RA)	Anti-roll bar required on rear axle; The wing seam on the front and rear axle must be flared only for vehicles with sports chassis (exception: 944 S2 also with standard chassis) When converting to 17-inch, the rubber mounts must be replaced with 951.341.023.01 and the eccentric pins with 951.341.431.01.

Winter tire approval for 944 Turbo (engine power 184 kW) and 944 S2 with chassis R01		
Tire size	Wheels	Comments
205/55 R 16 M+S	7Jx16, RO 65 (FA) 8 J x 16, RO 52.3/60 (RA)	
	7.5Jx16, RO 65 (FA) 8 J x 16, RO 52.3 (RA)	
205/55 R 16 M+S (FA) 225/50 R 16 M+S (RA)	7Jx16, RO 65 (FA) 8 J x 16, RO 52.3 (RA)	
	7.5Jx16, RO 65 (FA) 8 J x 16, RO 52.3 (RA)	
205/50 R 17 M+S (FA) 225/45 R 17 M+S (RA)	7.5Jx17, RO 65 (FA) 8Jx17, RO 52 (RA)	The wing seam on the rear axle must be flared When converting to 17-inch, the rubber mounts must be replaced with 951.341.023.01 and the eccentric pins with 951.341.431.01.

Further detailed information about permitted wheel and tire sizes as well as spacers that may be required can be found in the relevant parts certificates/manufacturer's certificates held by the Porsche partners.



Information

If a tire is damaged and it is not possible to determine with absolute certainty that there is no ply damage - with all of its consequences - or if the tire was thermally and/or mechanically overloaded due to a loss of pressure or other prior damage, replace the tire in question for safety reasons.

Repairs to "V", "W", "Y" and "ZR" tires are not permissible, as well as the use of inner tubes in tubeless tires. Please inform your customers accordingly. It is advisable to mount winter tires at temperatures below **45° F/7°C**, because the driving characteristics of summer tires are reduced at low temperatures. Extremely low temperatures can cause permanent damage to summer tires.



Incorrect tire pressure

- **Uncontrollable vehicle handling**
 - ⇒ **Adjust the tire pressure according to specifications. Never allow the pressure to fall below the minimum pressure.**
 - ⇒ **Check age of tires. Replace tires that are more than 6 years old.**
 - ⇒ **Perform visual inspections.**
 - ⇒ **Use new rubber valves at every tire change.**
 - ⇒ **Use only tires approved by Porsche.**



Information

N... = Specification code of the tire, e.g. "N0", "N1", "N2" ... The complete "N ..." code of the tires in question must be shown on the tire sidewall near the tire type designation.

Instructions for correct mounting of the tires are also given on the tire sidewall. If there are no mounting instructions on the tire sidewall, the tire must be mounted so that the DOT marking is visible from the outside.



Information

The tire pressure applies only to the tire makes and types approved by Porsche, and is specified for cold tires (approx. **68° F/20°C**). The tire pressures must never be lower than the specified values.



Information

Improper handling can damage the wheel surface.
Carry out tire removal and mounting using a bead holding-down device only.
Use a leather pad on the rim flange to support the valve insertion tool.
Only use the Porsche centering clamping set for balancing.
Do not use brushes to clean the wheels because brushes can cause deep scratches that cannot be removed by polishing.
Never use solvents or other chemical substances on tires.

Wheels:

Overview of Porsche wheels

Identification on the inside/outside of the wheel disc:
Wheel size, rim offset (RO) in mm, Part No. and Porsche logo

7J x 15 H2, RO 52.3

8J x 16 H2, RO 52.3

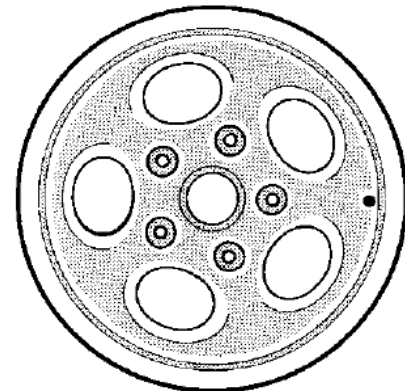

Light alloy cast

7J x 16 H2, RO 65

8J x 16 H2, RO 52.3

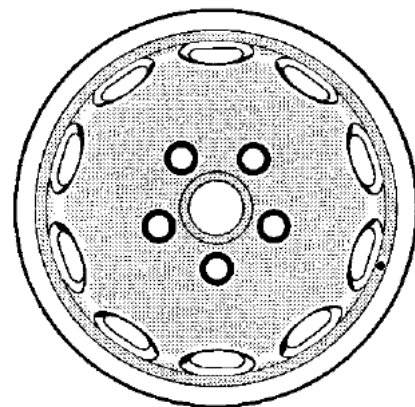

Light alloy cast

7J x 16 H2, R0 55
7.5J x 16 H2, R0 65
8J x 16 H2, R0 52.3
9J x 16 H2, R0 52.3

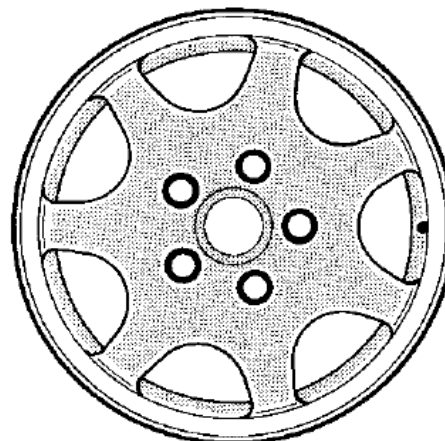

Design 90

7J x 16 H2, R0 65
8J x 16 H2, R0 60
9J x 16 H2, R0 60

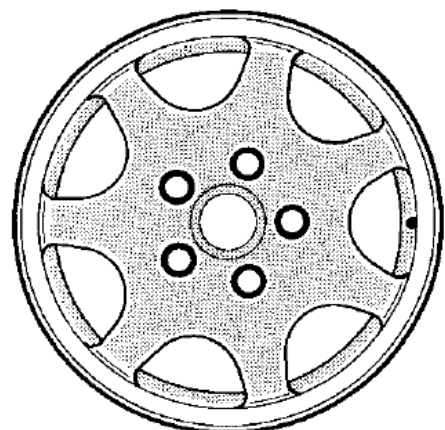

CS Design

7J x 16 H2, R0 52.3
7J x 16 H2, R0 65
8J x 16 H2, R0 52.3

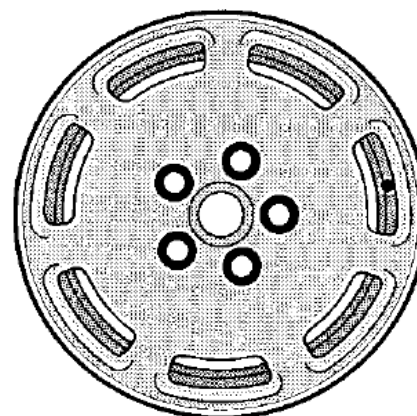

Forged light alloy

4

Freigabe/Approval

4400 ENU 28/21

Manufacturer's Certificate

7J x 16 H2, R0 55
8J x 16 H2, R0 52

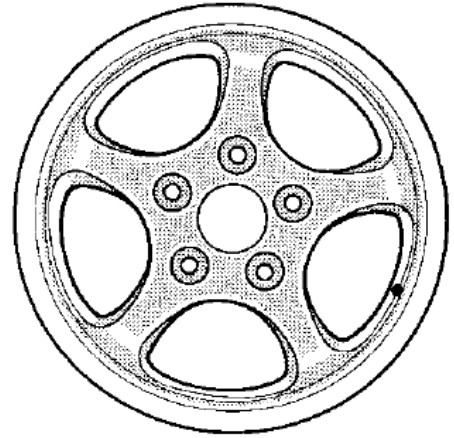

Cup Design

7.5J x 17 AH, RO 65
 8J x 17 AH, RO 52
 9J x 17 AH, RO 55
 9.5J x 17 AH, RO 68

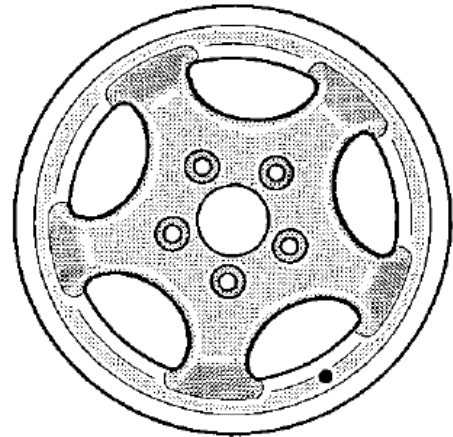

Cup Design

7.5J x 17 H2, RO 65
 8J x 17 H2, RO 52
 9J x 17 H2, RO 55

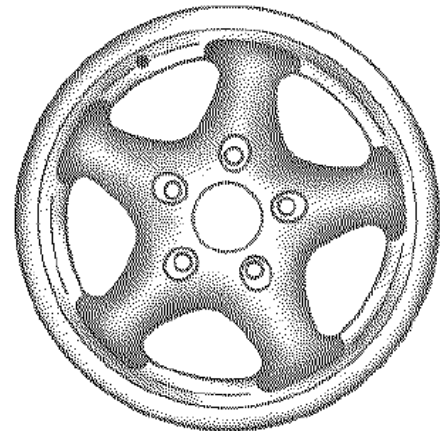

Cup Design 93

Tire pressure
 air:

944	15-inch and 16-inch wheels	17-inch wheels
Front axle	2.0 bar	2.5 bar
Rear axle	2.5 bar	2.5 bar

944 S, 944 S2, 944 Turbo	15-inch and 16-inch wheels	17-inch wheels
Front axle	2.0 bar	2.5 bar
Rear axle	2.5 bar	2.5 bar
	3.0 bar optionally 944 S2 Mod. 90; 944 Turbo from Mod. 90	

Wheel Mounting: The tightening torque for securing wheels and spacers is **130 Nm (96 ftlb.)**.

- Wheel Storage:
- Tires must be stored in a cool, dry and dark room with adequate ventilation.
 - Tires must never come into contact with fuel, oil, grease or chemicals.
 - Do not store summer tires in storage areas with ambient temperatures of less than 5° F (-15° C).
 - Complete wheel & tire assemblies can be stacked for storage; we recommend that you increase the tire pressure by approximately 6 psi (0.4 bar).
 - Optimum conditions for storage of the complete wheels are provided by the Original Porsche storage trolley, Part No. 000.044.000.38.
 - If the tires are not mounted on wheels, it is best to store them in a vertical position.
 - We recommend that you turn tires stored in this position every two weeks in order to prevent flat spots.
 - Tires that are stacked in a horizontal position will become severely deformed and cannot be seated properly in the rim flange when they are mounted.

- General Information:
- Always use new valves when changing tires.
 - Always observe any possible instructions concerning the rolling direction and/or specifying which side the tires must be mounted on.
 - Coat the tire beads and humps with mounting lubricant before mounting the tire. This ensures that the tire beads will slide over the humps easily.
 - In order to prevent the tire from turning on the wheel, avoid extreme driving maneuvers (acceleration and braking) during the first 100 to 200 miles with new or recently mounted tires.
 - In order to optimize smoothness of rolling, it is appropriate - and necessary in individual cases - to mount the tire in a certain (favorable) position with respect to the wheel (matching).

Matching (uncontrolled and controlled) is explained below: Uncontrolled matching:

- Turning the tire on the wheel by 90° or 120° if necessary in order to achieve an acceptable value with regard to rolling smoothness (true running, imbalance and weight distribution of balance weights).

Controlled matching:

- With a balancing machine with matching program. In most cases, this produces an even better result with regard to the rolling smoothness (true running, imbalance and weight distribution of the balance weights) than can be achieved with uncontrolled matching.
- Maximum permissible radial runout and lateral runout of the wheels < 0.7 mm. Maximum permissible radial runout and lateral runout of the wheels with tires < 1.25 mm. Values < 1.50 mm -ideally approx. 0.5 mm - are desirable.
- The mounting pressure (seating pressure) of 58 psi/4.0 bar overpressure must not be exceeded before both tire beads are evenly seated on the rim flange.

New Tires (Replacements):

- If new tires are to be mounted or the tires of one axle are to be replaced, tires of the same make, type and with the same specification code must always be used on each of the two axles.

- If tires are replaced on one axle only, the different tread depth from that on the other axle can cause a noticeable change in the familiar handling.
- This is especially the case if new tires are mounted on the rear axle.
- This effect decreases with increasing tire mileage.

When replacing a tire on an axle, make sure that the tread depth of the new tire does not differ from that of the other tire on the same axle by more than 30 %.

Refer to WM 449503 for specific details of the vehicle you are working on.

- >The 2mm specification will be given here.
- > If there is none listed then the default is 30%.

Repairs to Tires:

- If a tire is damaged and it cannot be determined with absolute certainty that there is no ply damage - with all of its consequences - or if the tire was thermally or mechanically overloaded due to a loss of pressure or other prior damage, we recommend replacement of the tire in question for safety reasons.
- Repairs to "V", "W", "Y" and "ZR" tires are not permissible, as is the use of inner tubes in tubeless tires.

Tire Aging:

- Tires age due to chemical and physical processes, which can impair their function.
- Tires that are stored unused for an extended period harden and become brittle faster than tires that are in continual use.
- Hairline aging cracks can occur on older tires.
- On tires in continual use, the kneading action activates the plasticizer in the rubber and thereby prevents hardening and cracking.
- Therefore, attention should be paid not only to the tread depth but also to the age of the tire.
- Tires should not be older than 6 years.
- The age of the tire can be determined via the DOT code on the sidewall, which indicates the production date of the tire: e.g. DOT 2201 = 22nd week of 2001.

Important Notice: Technical Bulletins issued by Porsche Cars North America, Inc. are intended only for use by professional automotive technicians who have attended Porsche service training courses. They are written to inform those technicians of conditions that may occur on some Porsche vehicles, or to provide information that could assist in the proper servicing of a vehicle. Porsche special tools may be necessary in order to perform certain operations identified in these bulletins. Use of tools and procedures other than those Porsche recommends in these bulletins may be detrimental to the safe operation of your vehicle, and may endanger the people working on it. Properly trained Porsche technicians have the equipment, tools, safety instructions, and know-how to do the job properly and safely. Part numbers listed in these bulletins are for reference only. The work procedures updated electronically in the Porsche PIWIS diagnostic and testing device take precedence and, in the event of a discrepancy, the work procedures in the PIWIS Tester are the ones that must be followed.

© 2021 Porsche Cars North America, Inc.