

06/16/2021
CAL WS 31-001

Subject: 4-Hook Chain Hanger Replacement

Models Affected: Specific Western Star 5700 vehicles equipped with 22 inch 4-hook chain hangers manufactured between September 15, 2020 and March 22, 2021

Parts

Replacement 6-Hook Chain Hanger Part Numbers	
4-Hook Hanger Part Numbers	6-Hook Hanger Part Numbers
22-78429-000	PRT35 5962GH
22-78429-001	PRT35 5951GH
22-78429-002	PRT35 5950GH

Table 1, Replacement 6-Hook Chain Hanger Part Numbers

Work Instructions

1. Park the vehicle on a level surface, shut down the engine, and set the parking brake. Chock the rear tires.
2. Locate the chain hanger in the mid-chassis area of the vehicle. The chain hanger will be either on the left-hand or right-hand side of the chassis, forward of the rear axle. See **Fig. 1**.

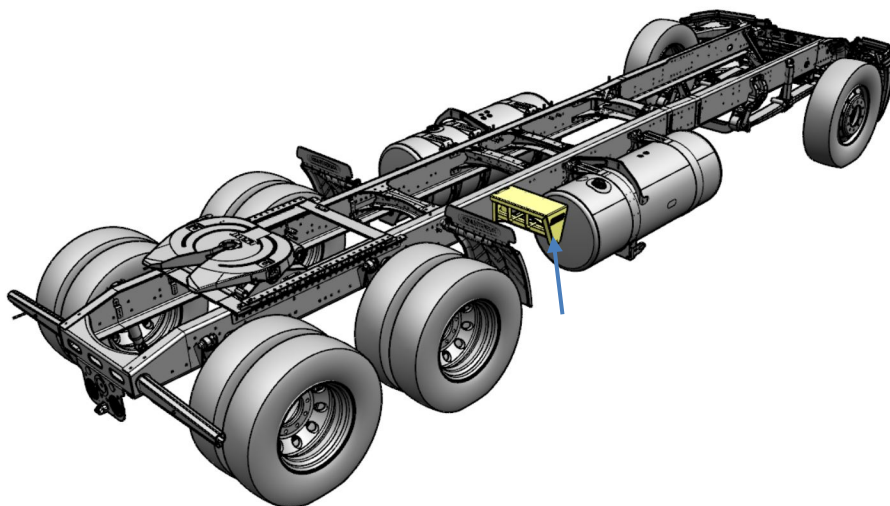
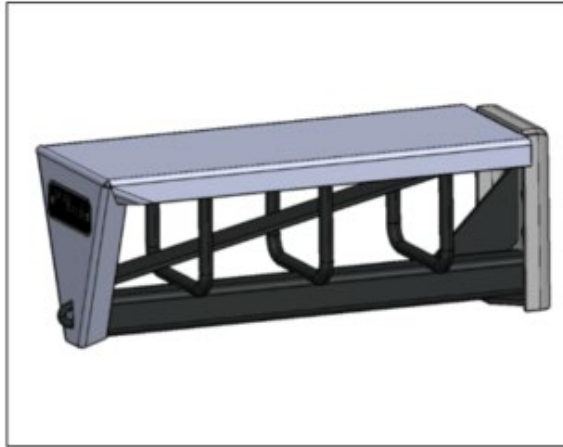
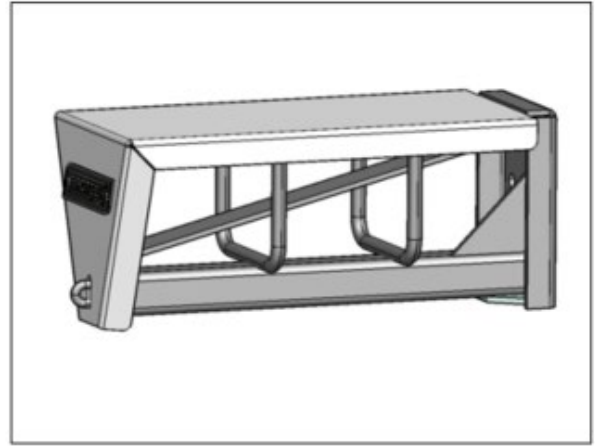

Fig. 1, Chain Hanger (right-hand location shown)

- The 22 inch long chain hanger has four hooks to accommodate tire chains. The replacement 24 inch long chain hanger has six hooks to accommodate tire chains. See **Fig. 2**.



24" long 6-hook hanger



22" long 4-hook hanger

Fig. 2, Six and Four Hook Tire Chain Hangers

- Loosen the four fasteners attaching the chain hanger to the frame rail, then remove the 4-hook chain hanger. Discard the fasteners.
- Clean the frame rail area where the chain hanger was installed.
- Install the new 6-hook chain hanger to the frame rail with new bolts and nuts. See **Table 1** for part numbers. Tighten the nuts to the torque values listed in **Table 2**.

6-Hook Chain Hanger Fastener Torque Values		
Nut Thread	Coating Color	Torque
M16 x 1.5	VLh Blue	174 lbf•ft (235 N•m)
M16 x 1.5	XL Black	129 lbf•ft (175 N•m)
5/8" - 11	VLh Green	174 lbf•ft (235 N•m)
5/8" - 11	XL Silver	129 lbf•ft (175 N•m)

Table 2, 6-Hook Chain Hanger Fastener Torque Values