

June 18, 2021

Version 6

Warranty Extension: 2016-21 Civic A/C CondenserSupersedes 19-091, dated May 28, 2021, to revise the information in **yellow**.**AFFECTED VEHICLES**

Year	Model	Trim Level	VIN Range
2016-20	Civic 2- and 4-Door	ALL	Check the iN VIN status for eligibility.
2017-21	Civic 5-Door (except Type R)*	ALL	Check the iN VIN status for eligibility.

*For Civic Type R, see 21-014, *Warranty Extension: 2017-21 Civic Type R A/C Condenser*.**REVISION SUMMARY**

- Under PARTS INFORMATION, new part numbers were added.
- Under WARRANTY CLAIM INFORMATION, new claim information was added.

BACKGROUND

American Honda is extending the warranty on the A/C condenser to 10 years from the original date of purchase with unlimited miles.

This warranty extension only covers vehicles that have a defective A/C condenser from the factory. The A/C condenser was not manufactured to specification. As a result, corrosion may develop in the form of tiny holes in the condenser tube walls that allow the refrigerant to leak out.

This does not apply to any vehicle that has a leaking condenser due to foreign object damage.

It also does not apply to any vehicle that has ever been declared a total loss or sold for salvage by a financial institution or insurer, or has a branded or similar title under any state's law.

CUSTOMER NOTIFICATION

Owners of affected vehicles will be sent a notification of this campaign.

Do an iN VIN status inquiry to make sure the vehicle is shown as eligible.

CORRECTIVE ACTION

Do the inspection procedure and, only if there is a leak in the A/C condenser caused by corrosion or other manufacturing condition, replace it.

CUSTOMER INFORMATION: The information in this bulletin is intended for use only by skilled technicians who have the proper tools, equipment, and training to correctly and safely maintain your vehicle. These procedures should not be attempted by "do-it-yourselfers," and you should not assume this bulletin applies to your vehicle, or that your vehicle has the condition described. To determine whether this information applies, contact an authorized Honda automobile dealer.

PARTS INFORMATION

Part Name	Part Number	Quantity
Condenser Assembly (2.0 L)	80100-TBA-A01 or 80100-TBA-A02	1
Condenser Assembly (1.5T)	80100-TBC-A01 or 80100-TBC-A02	
O-Ring (1/2 in)	80872-SN7-003	1
O-Ring (8 mm)	80873-ST7-000	1

REQUIRED MATERIALS

NOTE: Once you open the POE Compressor Oil container, dispose of it. Do not store it or reuse.

Part Name	Part Number	Quantity
POE Compressor Oil	38899-RLV-A01	1
1234yf Refrigerant	08799-0003	Refer to service bulletin 16-064 for calculation instructions.

TOOL INFORMATION

Tool Name	Part Number	Quantity
R-1234yf A/C Recover, Recycle, Recharge Machine	ROB421234	1
R-1234yf Leak Detection Kit	TRP1234YFA	1
Marksman II Ultrasonic Leak Detector	TRPT9367L	1

WARRANTY CLAIM INFORMATION

Civic 1.5T & 2.0 L

Operation Number	Description	Flat Rate Time	Defect Code	Symptom Code	Template ID	Failed Part Number
6165A3	Inspect the A/C system for leaks.	1.1 hr	6C300	G5O00	A19091D	80100-TBA-A01

Civic 1.5T Only (Using replacement P/N 80100-TBC-A02)

Operation Number	Description	Flat Rate Time	Defect Code	Symptom Code	Template ID	Failed Part Number
6161M3	Inspect the A/C system for leaks.	1.1 hr	6C300	G5O00	A19091E	80100-TBC-A01
A	1.5T - Replace the condenser (Includes refrigerant evacuation and recharge).	1.1 hr				

Civic 2.0 L Only (Using replacement P/N 80100-TBA-A02)

Operation Number	Description	Flat Rate Time	Defect Code	Symptom Code	Template ID	Failed Part Number
6161M3	Inspect the A/C system for leaks.	1.1 hr	6C300	G5O00	A19091F	80100-TBA-A01
B	2.0 L - Replace the condenser (Includes refrigerant evacuation and recharge).	1.2 hr				

Civic 1.5T Only (Using replacement P/N 80100-TBC-A01)

Operation Number	Description	Flat Rate Time	Defect Code	Symptom Code	Template ID	Failed Part Number
6161M3	Inspect the A/C system for leaks.	1.1 hr	6C300	G5O00	A19091G	80100-TBC-A01
A	1.5T - Replace the condenser (Includes refrigerant evacuation and recharge).	1.1 hr				

Civic 2.0 L Only (Using replacement P/N 80100-TBA-A01)

Operation Number	Description	Flat Rate Time	Defect Code	Symptom Code	Template ID	Failed Part Number
6161M3	Inspect the A/C system for leaks.	1.1 hr	6C300	G5O00	A19091H	80100-TBA-A01
B	2.0 L - Replace the condenser (Includes refrigerant evacuation and recharge).	1.2 hr				

Skill Level: Repair Technician

INSPECTION PROCEDURE

NOTE: Make sure you review the precautions when working with the A/C system.

1. Evacuate and recharge the A/C system with the appropriate dye for the vehicle.

NOTE:

- When using the Robinair R-1234yf A/C Recover, Recycle, Recharge Machine, a system vacuum is automatically done when it recharges the system. Use the automatic vacuum check for this bulletin.
 - For additional information on how to check if the condenser is leaking, go to service bulletin 07-030 *A/C Leak Detection*.
 - If the refrigerant level is low, the compressor may not activate. Fill the system with enough refrigerant to engage the compressor.
 - If there is a large leak in the system, the vacuum leak test may fail and you will be unable to add refrigerant to the system. In that case, continue to step 3, and use the ultrasonic leak detector with the system under vacuum to identify where the leak is. For details on how to use it, watch the *Tech2Tech* video, "Check for A/C Leaks with the Ultra Sonic Leak Detector."
2. Turn on the A/C, set the climate control to MAX COOL. If equipped, make sure the ECO switch is turned to OFF.

NOTE:

- Allow the dye to circulate in the A/C system for a minimum of **60 minutes** before inspecting for leaks. Continue to step 3 while the A/C system is circulating the dye.
 - If the customer is unable to leave the vehicle for an extended period, have the service advisor schedule a follow-up appointment 24 to 48 hours later.
3. Remove the front grille cover.

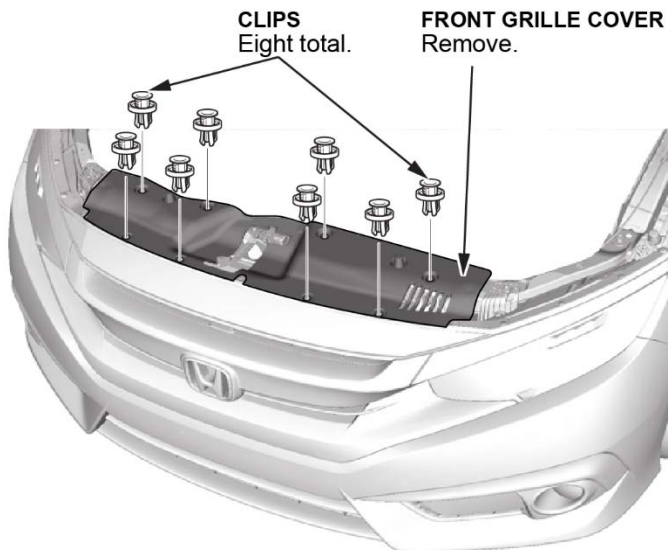

4. Remove the clips and hardware securing the front bumper.

2/4 DOOR

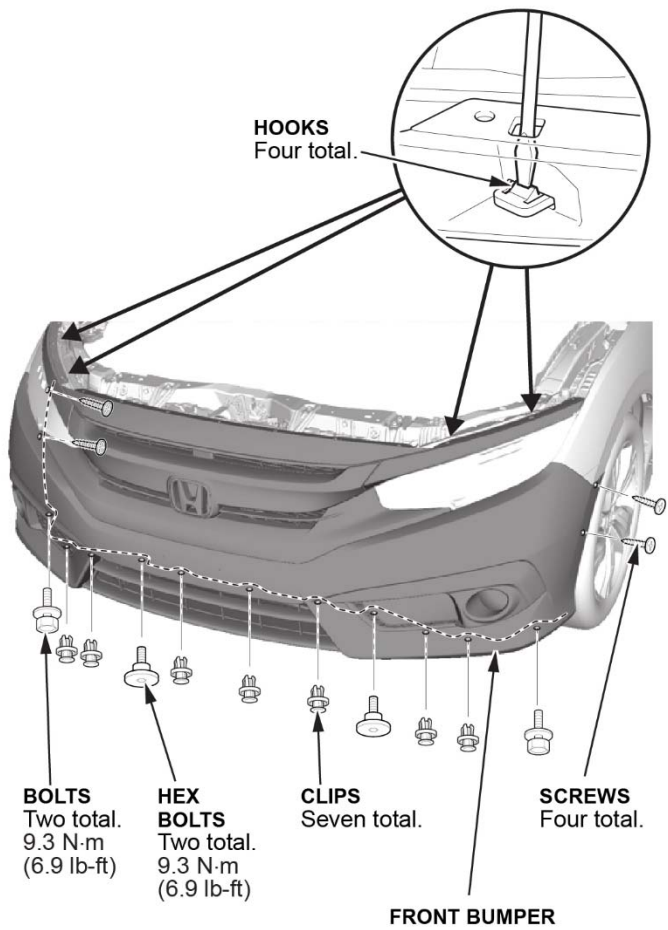

5 Door

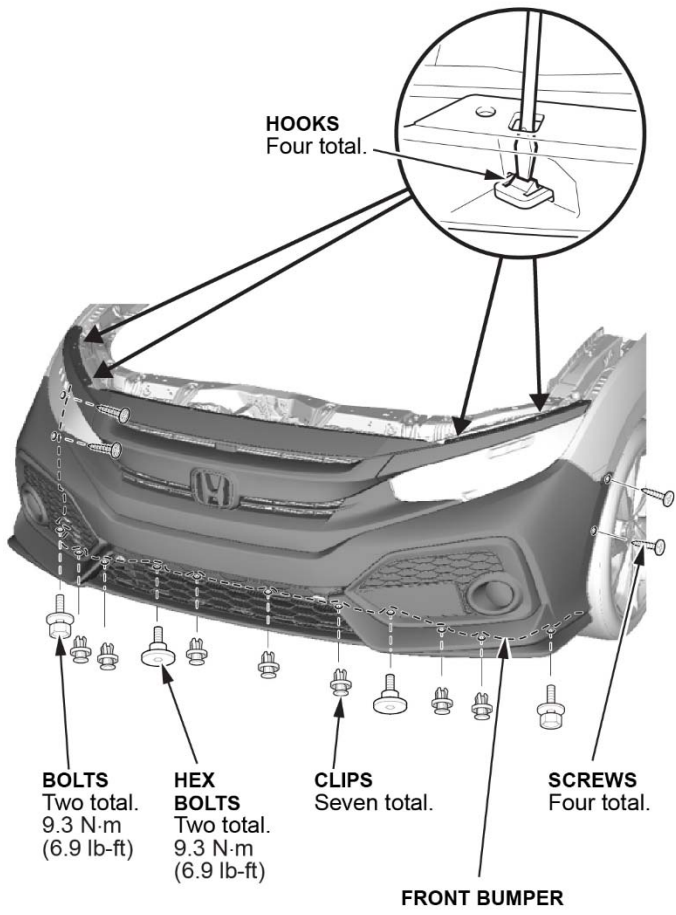

5. Pull the bumper out by both wheel wells to release it from the hooks on the side spacers.

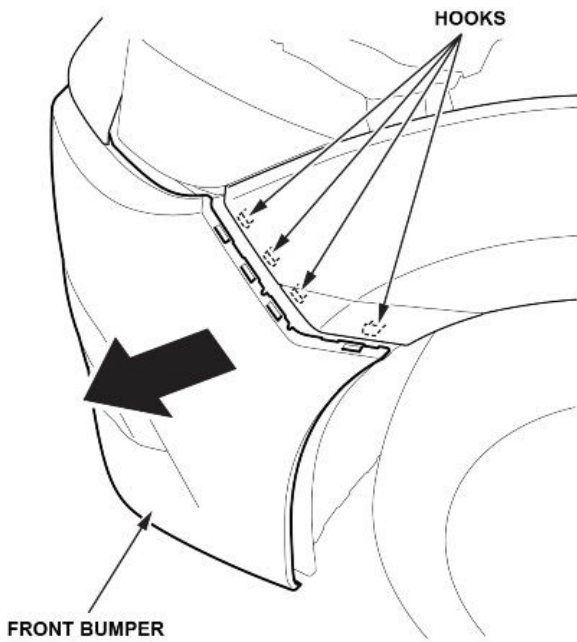

6. With the help of an assistant, pull the front bumper away from the side spacers, then release the bumper from the hooks on the upper beam.

With fog lights only: Disconnect the connectors.

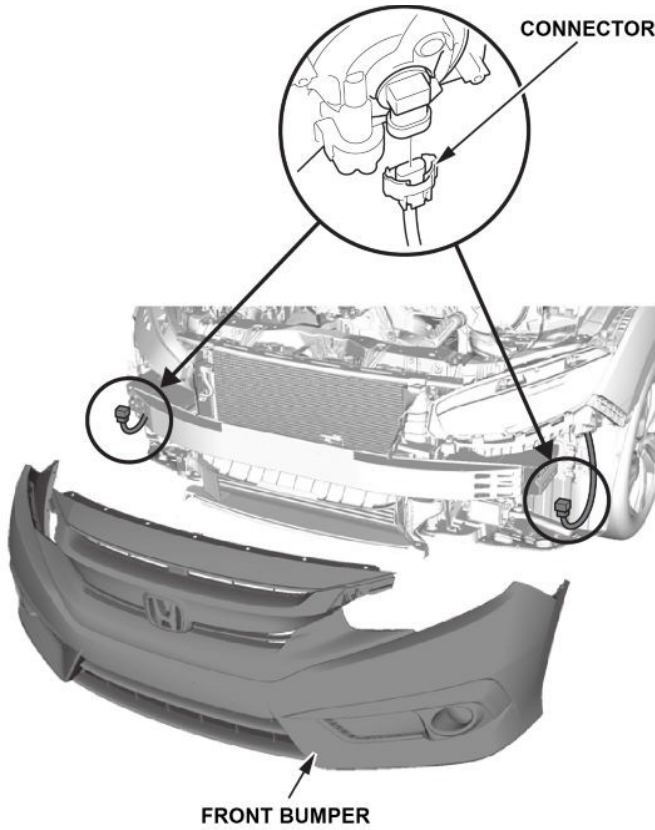

7. Check for leaks in the central condenser area.

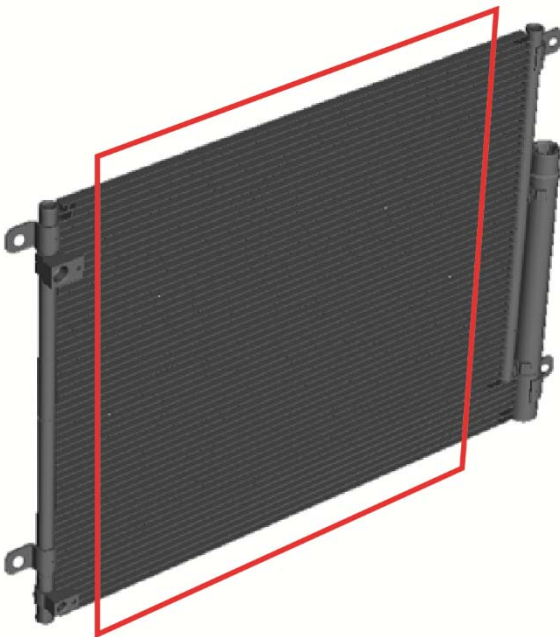

8. Check the joints between the horizontal tubes and the vertical pipes.

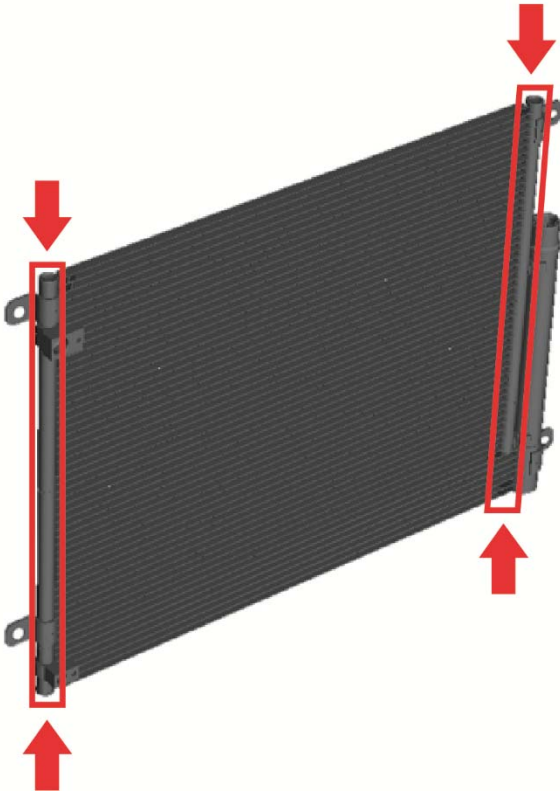

9. Check the inlet and outlet joints and the dryer cap for leaks.

NOTE: Leaks from the O-rings or the receiver/dryer cap are not covered by this bulletin.

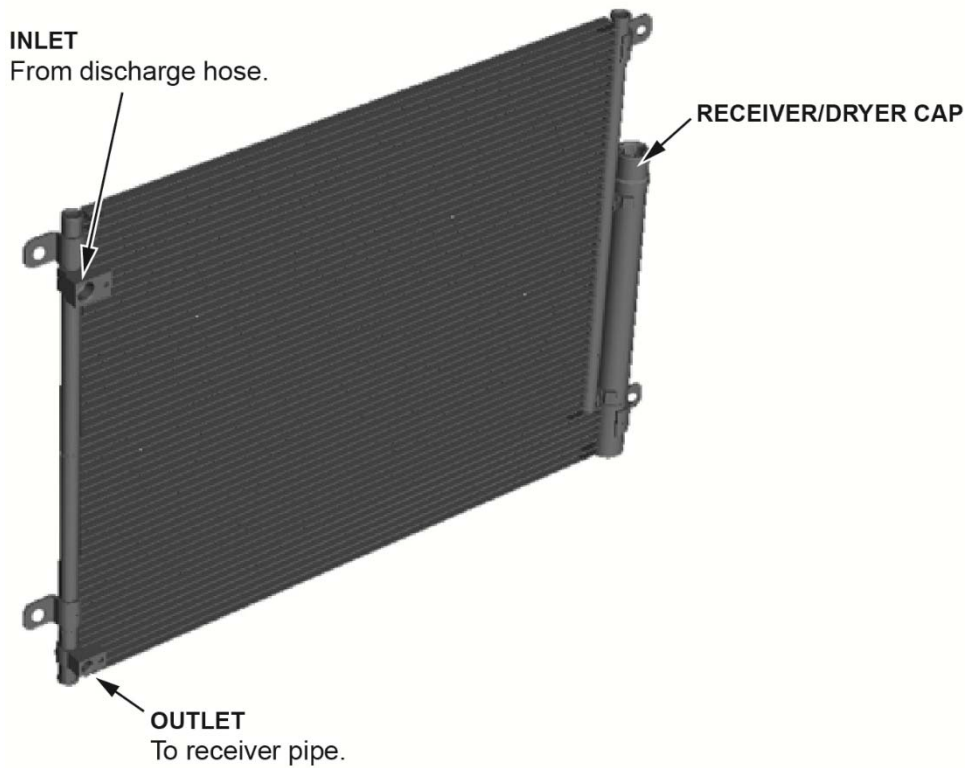

Examples of leaks detected with dye

Leaks will appear fluorescent green/yellow under UV light.

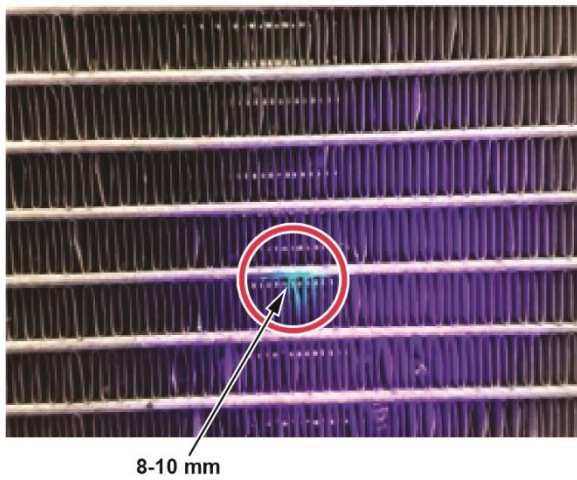

Some leaks are visible with the correct angle of UV light. This leak is deep in the groove between fins.

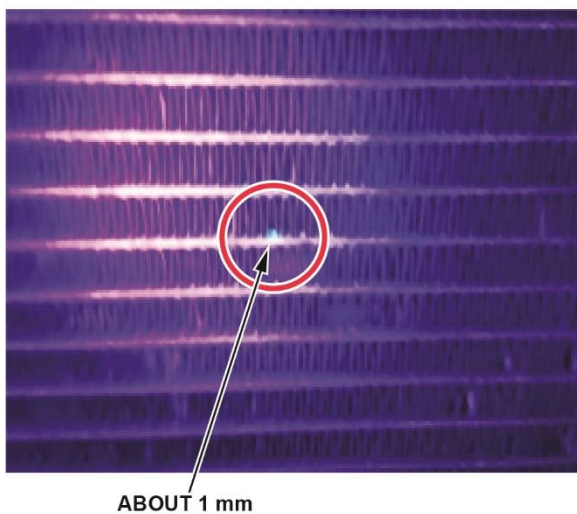

Some leaks may not be visible from certain angles. Aim the UV light from different angles to detect leaks on horizontal tube surfaces.

UV LIGHT POINTING DOWN

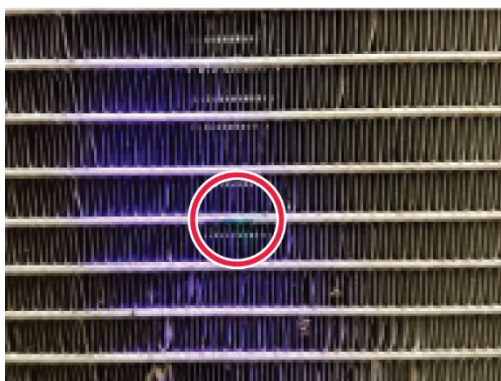

UV LIGHT POINTING UP



Some condensers may have multiple leaks.

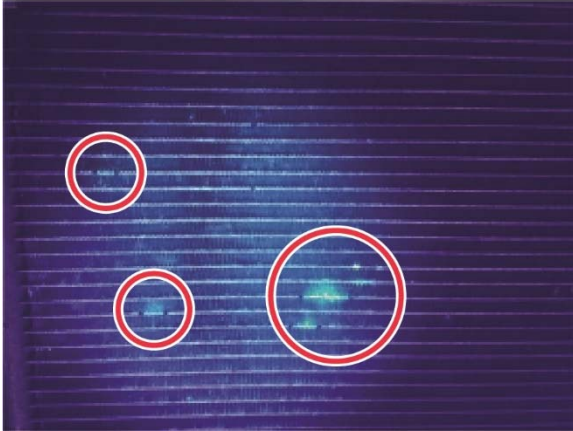

- *If the condenser is leaking, go to the next step.*
- *If the condenser is not leaking, this bulletin does not apply. Continue with normal troubleshooting.*

10. Check whether the leak was caused by a foreign object.

There are several types of damage that can result in a leak. This bulletin is for leaks that are caused by the manufacturing process. Damage like those caused by foreign objects that break the tube face are not covered under this warranty extension. A foreign object may damage the fins, but as long as the tube face is not impacted, the leak is covered under this warranty extension.

- Tube face damaged by foreign object – This bulletin does not apply. Continue with normal system troubleshooting.
- Foreign object damage but tube face is not damaged, or the tube face is corroded – Go to REPAIR PROCEDURE.
- No damage or corrosion found but the condenser is leaking – Go to REPAIR PROCEDURE.

***Foreign Object Did Not Damage Tube Face
Covered Under Warranty Extension***

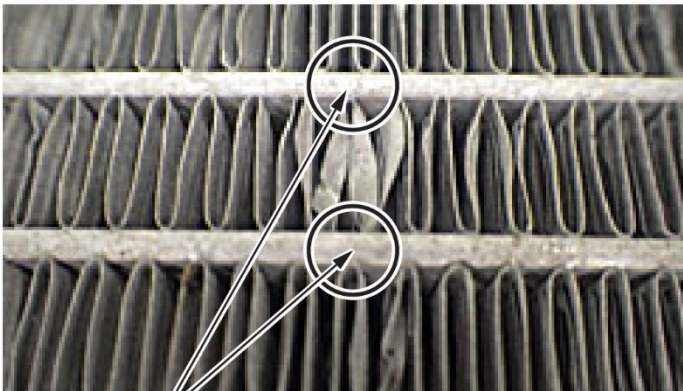

Fin damage without impact damage to the tube face.

***Foreign Object Damaged Tube Face
Not Covered Under Warranty Extension***

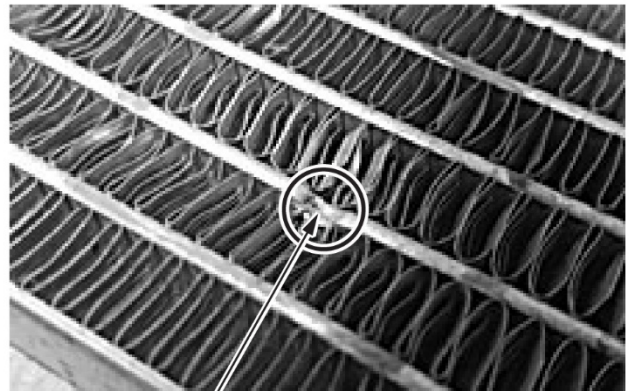

Impact damage on the tube face.

REPAIR PROCEDURE

NOTE:

- Only replace the A/C condenser under this warranty extension if it is leaking due to corrosion or manufacturing defect.
 - Make sure you review the precautions when working with the A/C system.
1. Follow the equipment manufacturer's instructions, and connect the A/C recover/recycle/recharge machine to the high-pressure service port and the low-pressure service port.

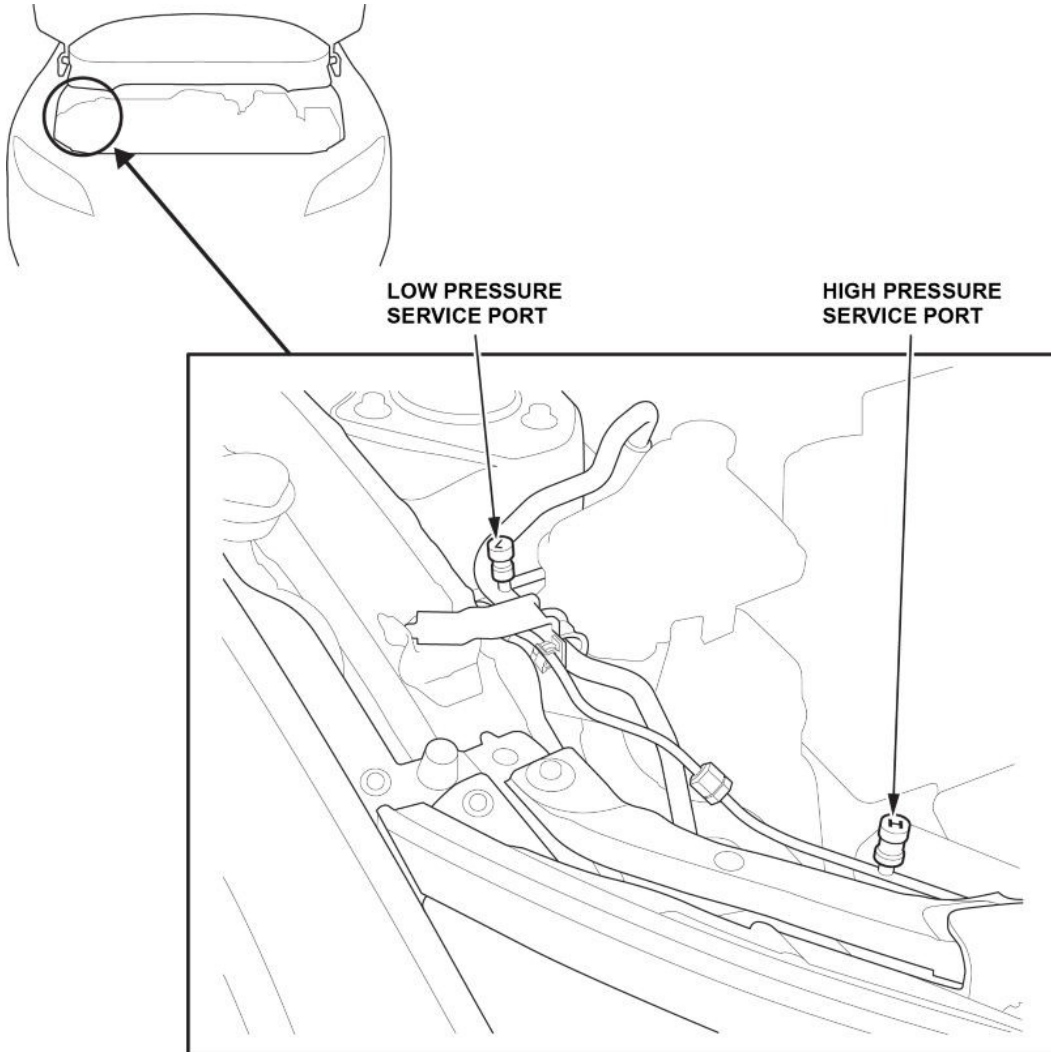

2. Recover the refrigerant from the A/C system.
3. Measure the amount of refrigerant oil removed from the A/C system after the recovery process is completed. Make sure to put the same amount of new refrigerant oil back into the A/C system before charging.

4. Remove the front bumper upper beam.

2.0 L

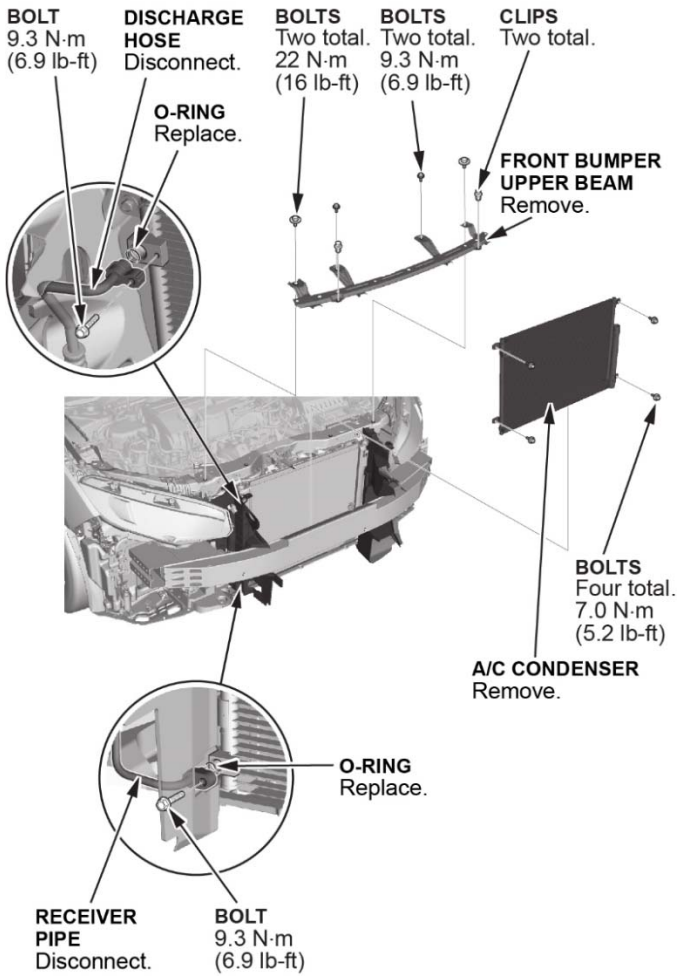

1.5 L

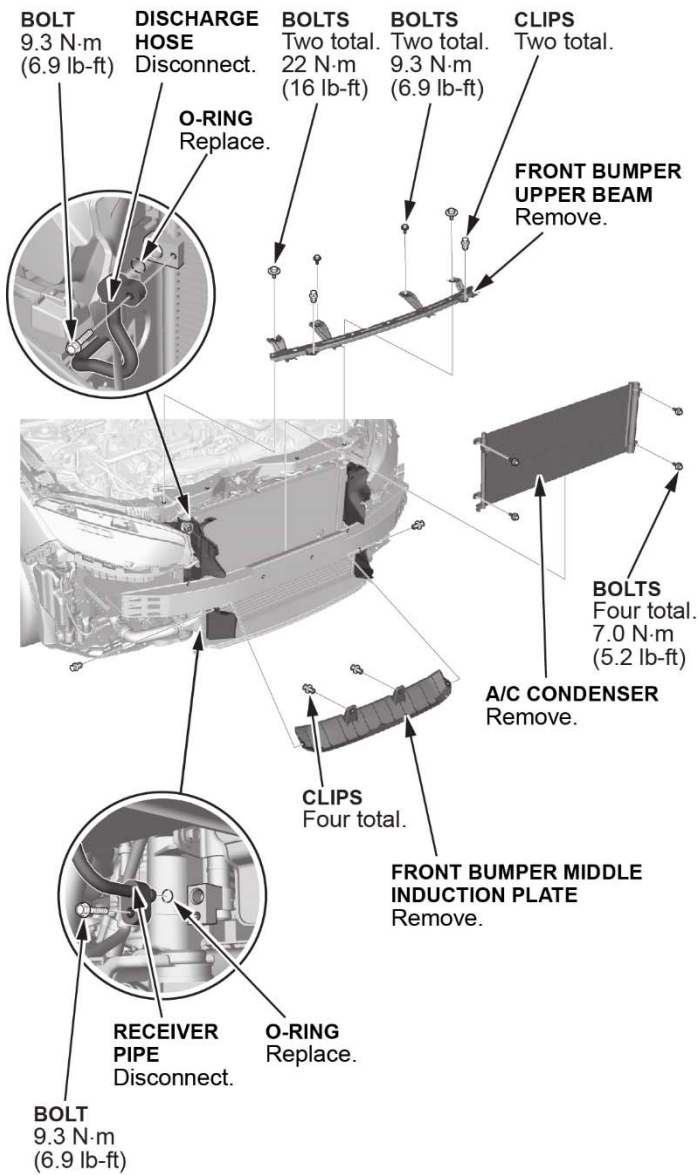

5. *With front bumper middle induction plate only:* Remove the front bumper middle induction plate.
6. Remove the discharge hose from the condenser.
7. Remove the receiver pipe from the condenser.
8. Remove the A/C condenser.
9. Install the new A/C condenser assembly.

10. Install all the removed parts in the reverse order of removal.

- Receiver pipe – replace the 8 mm O-ring (80873-ST7-000)
- Discharge hose – replace the 1/2 in O-ring (80872-SN7-003)
- Front bumper middle induction plate (if removed)
- Front bumper upper beam
- Fog light (Connect if disconnected)
- Front bumper
- Front grille cover

NOTE: Torque all fasteners to specification.

11. Add the necessary amount of refrigerant oil to the A/C system. Refer to A/C Refrigerant Oil Replacement in the service information.

12. Add the necessary amount of refrigerant to the A/C system. Refer to A/C Refrigerant Recovery/Evacuation/Charging in the service information.

13. Make sure there are no refrigerant leaks and the A/C system functions properly.

END