



**S-Series™**  
BACKED BY McNEILUS

# Technical Service Information Bulletin

## 2.0 Electrical Connections

**Date:** May 12, 2021

**Bulletin Name:** FDM-TSIB-024

**Model:** Oshkosh S-Series

**Units Affected:** 2.0 Front Discharge Mixers

### Purpose:

This bulletin provides instruction for checking electrical connections at various critical locations. Loose electrical connections can cause false readings and lead to electrical system errors.

### Notice:

- This bulletin should be read and understood in its entirety before performing this procedure.
- All procedures outlined in the bulletin must be performed by skilled service personnel. Refer to the product service manual for descriptions of maintenance procedures.

### SAFETY NOTICE

Perform your company's Lockout/Tagout procedure. If your company does not have a Lockout/Tagout procedure, follow OSHA 1910.147 and 1910.146 Confined Space as appropriate.

### SAFETY NOTICE

Use appropriate Personal Protective Equipment (PPE) as required by your company.

### Tools and Equipment Required:

Customer to supply:

- Hand Tools
- Electrical sealant

### Procedure:

#### *Lockout/Tagout*

1. Place unit on a flat surface, block truck tires, and perform your company's Lockout/Tagout procedure. If your company does not have a Lockout/Tagout procedure, follow OSHA 1910.147 and 1910.146 Confined Space as appropriate.
2. The vehicle's BATTERY DISCONNECT switch is located on the left-hand side of the battery box. Use the battery disconnect switch when performing any maintenance so the vehicle cannot accidentally be started.
  - a. Turn the battery disconnect switch (Figure A, Item 1) counterclockwise so the hole on the switch aligns with the hole in the bracket (Figure A, Item 2).
  - b. Install the safety lockout device ring (Figure B, Item 1) through the holes on the battery disconnect switch and the bracket.
  - c. Install a padlock (Figure B, Item 2) onto the safety lockout device ring, lock it, and put the key in your pocket. If more than one person is working on the vehicle, each person must install his or her own padlock.

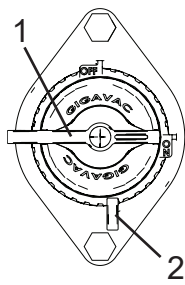

Figure A

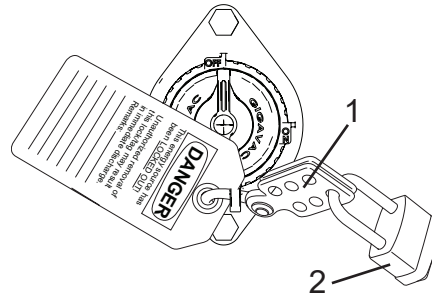

Figure B

### Cab Connections

#### NOTE

It may be necessary to remove electrical sealant from some connections to verify torques. Reapply an electrical sealant after verifying torque to protect the connection.

3. Check the power distribution modules (PDMs), large cab relay, and cab pass-thru connector nuts (both inside and outside under the cab) torques. See Figure 1.

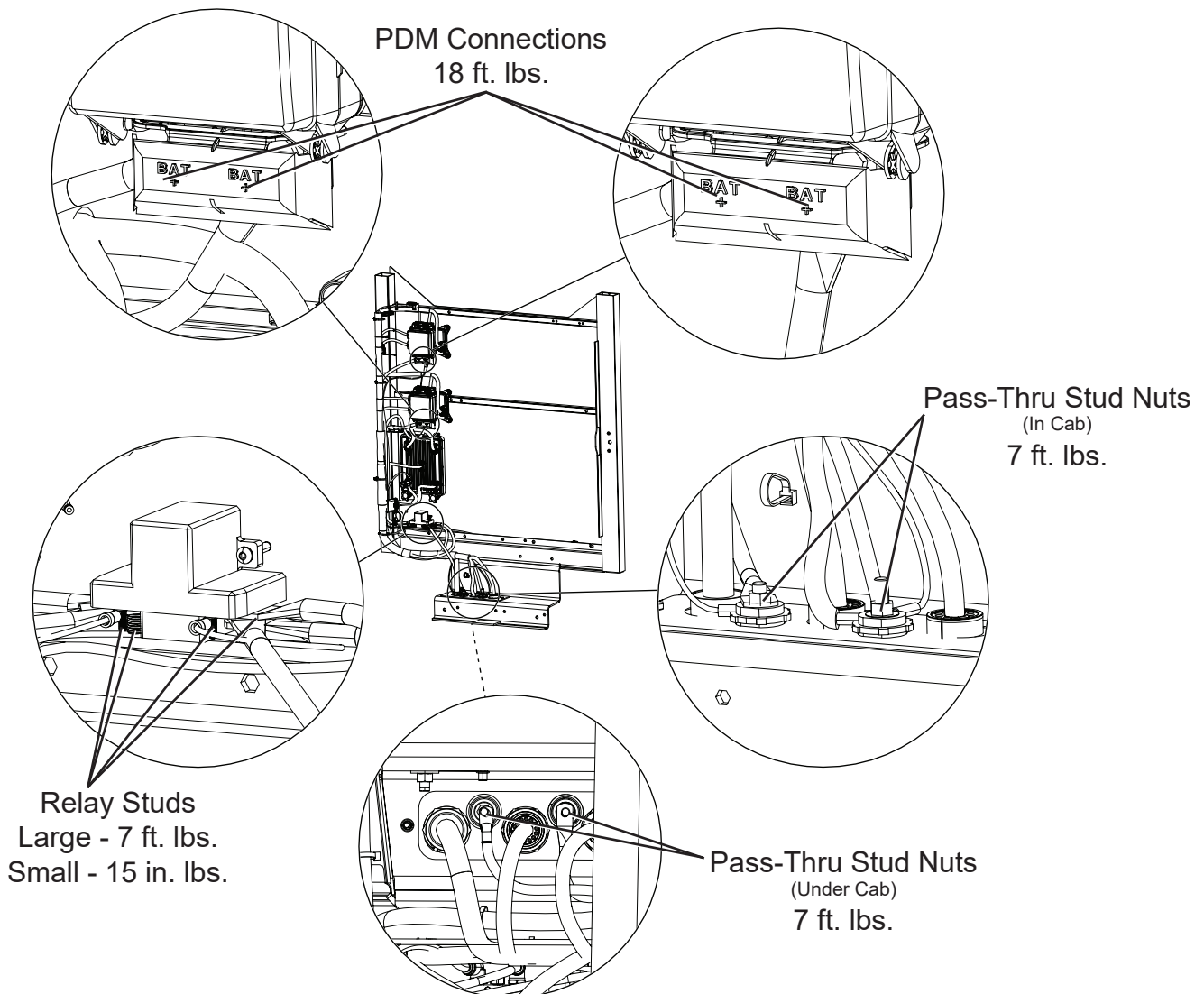

Figure 1

**Rear of Truck Connections**

- 4. Check the rear PDM connections (located on the back of the cooling support) torque, see Figure 2.

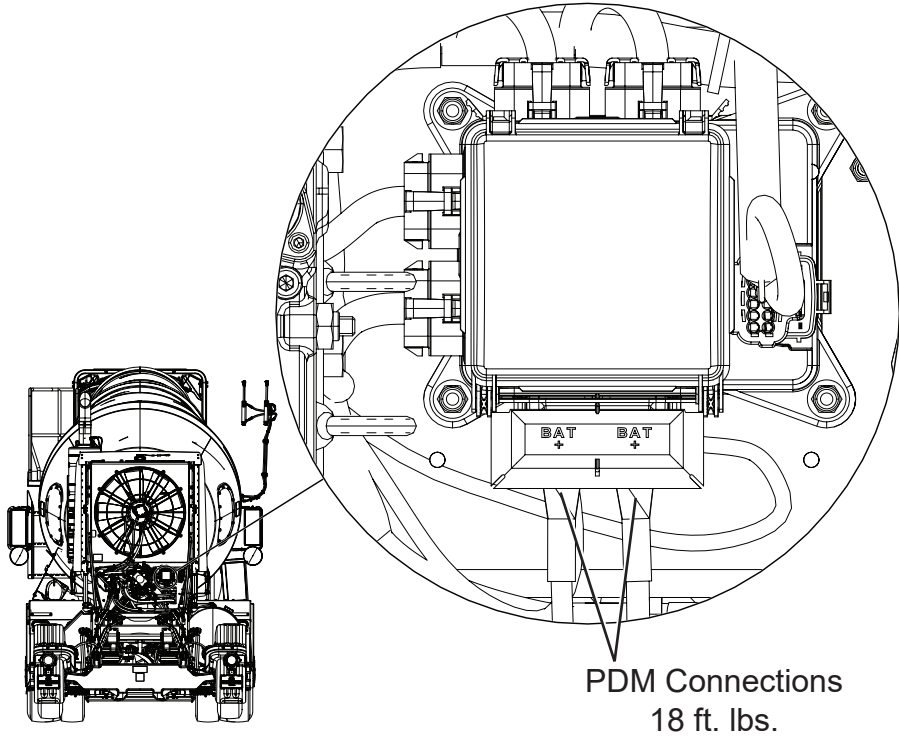

Figure 2

- 5. Check the battery terminal nuts and the bar terminal connections torque, see Figure 3.

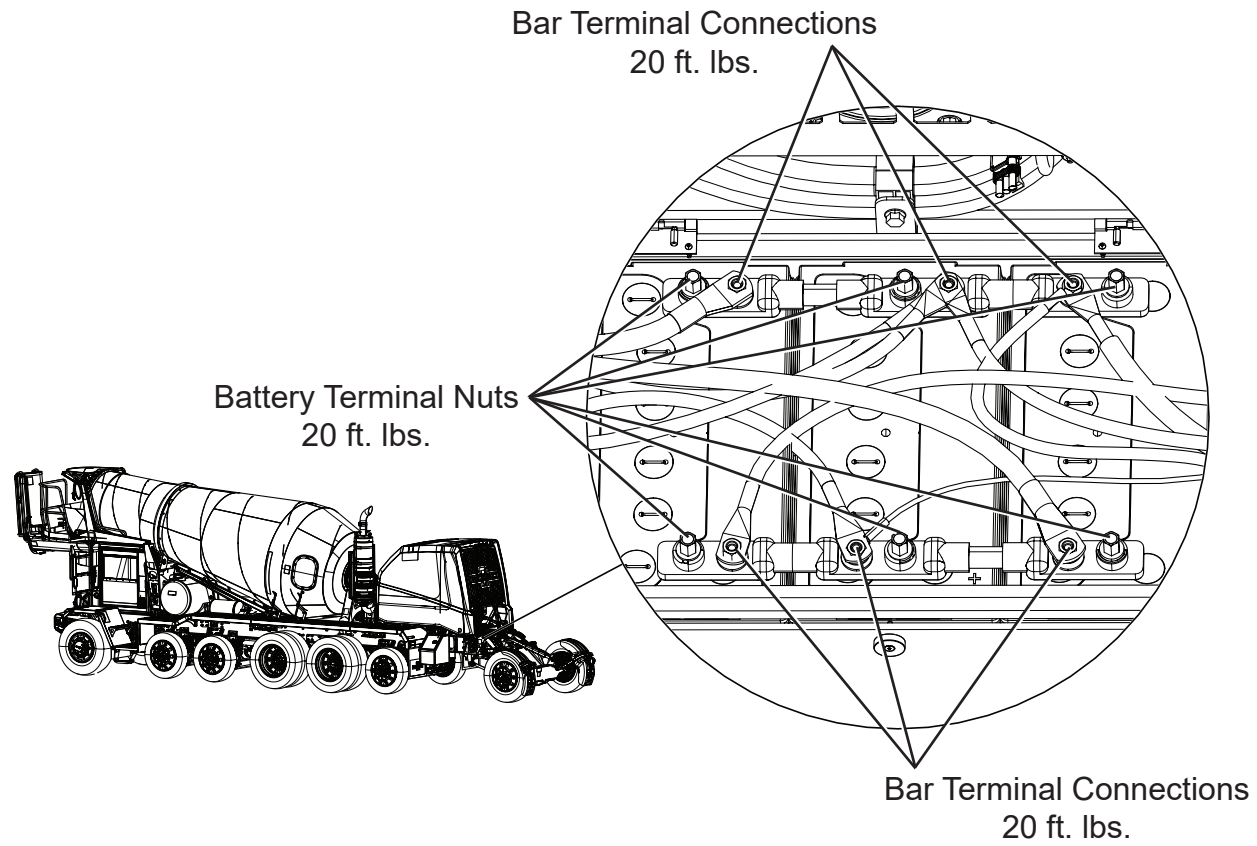

Figure 3

6. Check the frame grounding stud nut (located on the right-hand frame rail forward of the battery box) torque, see Figure 4.

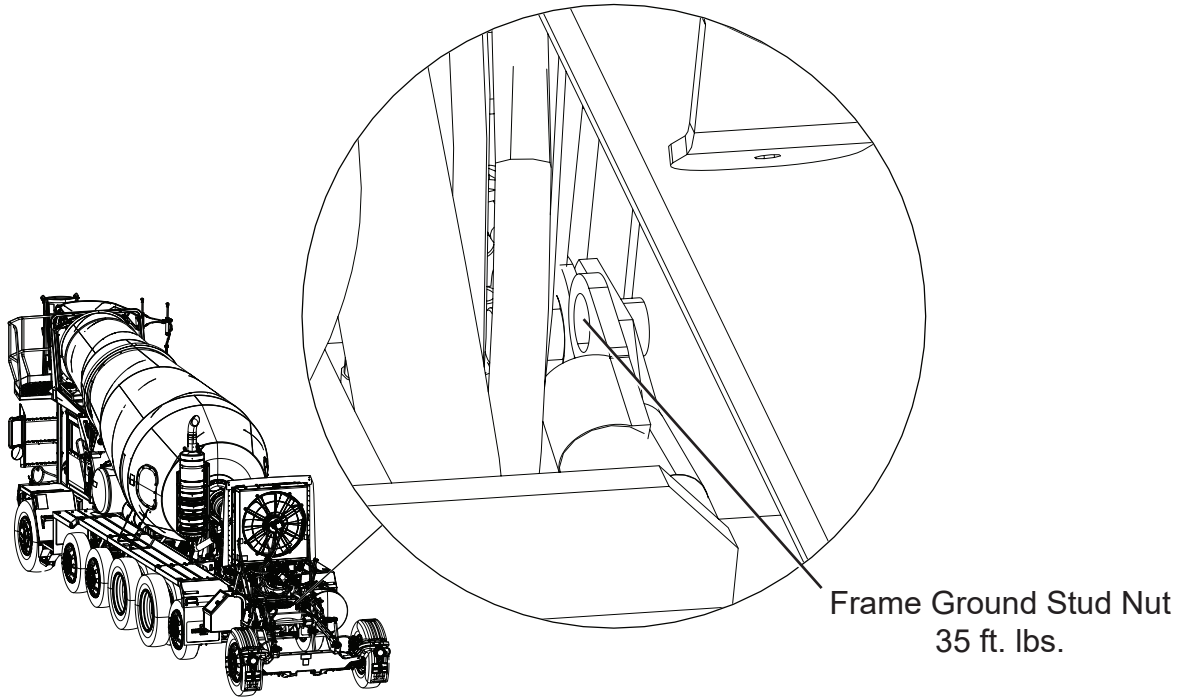

Figure 4

7. Check the positive (+) and negative (-) starter stud nuts torque, see Figure 5.

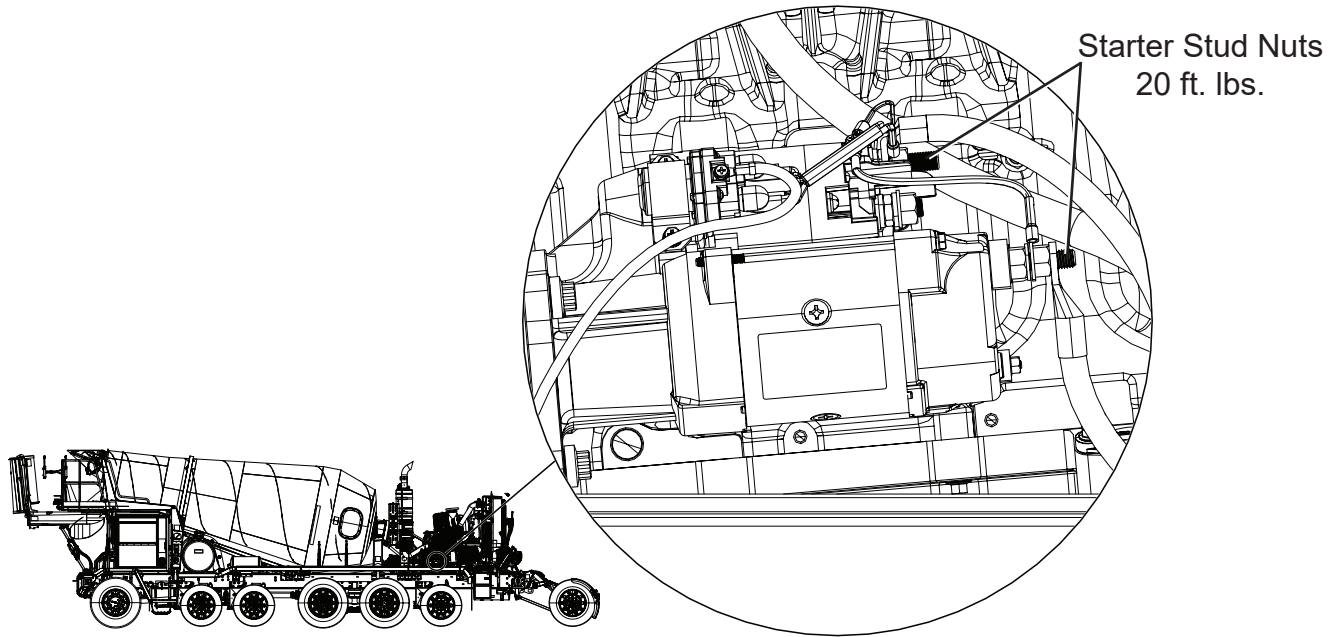

Figure 5

8. Check the battery disconnect stud nuts and fuse stud nuts torque, see Figure 6.

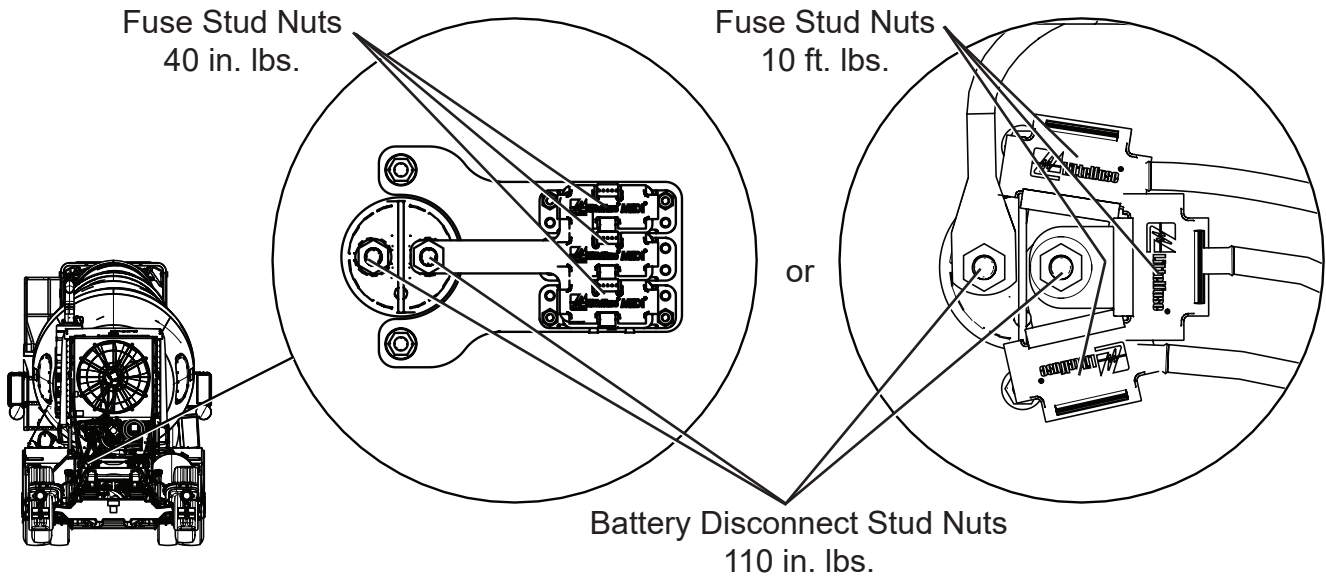

Figure 6

9. Check the small and large stud nuts on the battery box relay (located inside the battery box) torque, see Figure 7.

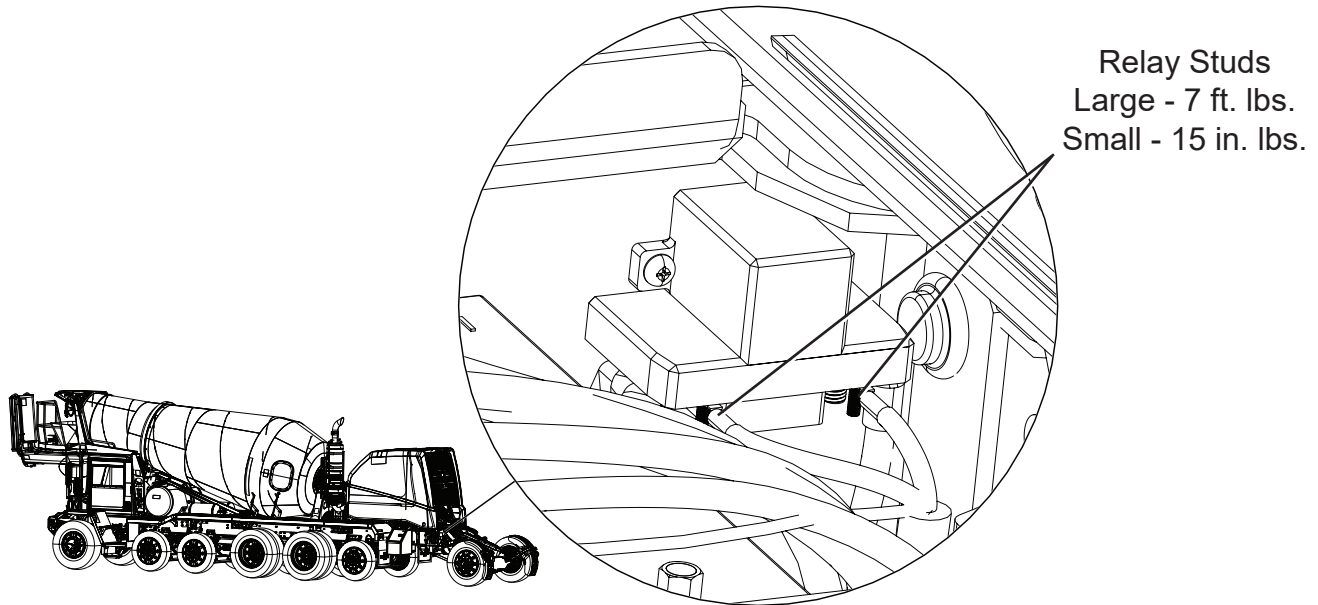

Figure 7

10. Remove lockout/tagout.

### Continuous Improvement:

The change included in this document is part of the McNeilus Continuous Improvement Process.

*McNeilus's quality policy is providing customer satisfaction through innovative products, dedicated service, and a constant focus on continuous improvement.*



(888) 686-7278

[www.streetsmartparts.com](http://www.streetsmartparts.com)