

AMA4 - Replacing or Repairing Engine (Stop Delivery/Recall Campaign)

Vehicle Type: **718 Spyder (982) / 718 Boxster GTS 4.0 (982)
718 Cayman GT4 (982) / 718 Cayman GTS 4.0 (982)**

Model Year: **2021**

- Equipment:
- **Engine type DWAA**
 - **Engine type DWAB**
 - **Engine type DWAC**
 - **Engine type DWAD**
 - **Engine type DKDA**
 - **Engine type DKDC**

Concerns: **Connecting rod bolts**

Information: **Connecting rods that were not manufactured according to specifications may have been installed in the engines of the affected vehicles. We cannot therefore rule out the possibility of the connecting rod bolts loosening over the service life of the vehicle.**

If this happens, you may hear noises from the crank drive while driving and the oil pressure warning in the instrument would come on. If the customer continues to drive the vehicle, however, oil can start leaking from the engine, and engine damage cannot be ruled out.

- Action required:
- Replacing engine
 - Replace vehicle-specific stickers showing the allocation of vehicle identification number to engine number



Information

For parts availability reasons, only the campaign scope "Replacing engine" is available for vehicles that have already been delivered to customers (Scope 1 – Scope 10).

Affected Vehicles: Only vehicles assigned to the campaign (see also PCSS Vehicle Information). This campaign affects 190 vehicles.

Parts required

Parts Info:

Part No.	Designation - Use	Qty.
V04015003J	⇒ Replacement engine (engine type DWAA/DKDA) - 718 Spyder/718 Cayman GT4 - with 6-speed manual gearbox (M-no. 480)	1 ea.
or		
V04015003K	⇒ Replacement engine (engine type DWAB) - 718 Spyder/718 Cayman GT4 - with Porsche Doppelkupplung (PDK) (M-no. 250)	1 ea.
or		
V04015003L	⇒ Replacement engine (engine type DWAC/DKDC) - 718 Boxster GTS 4.0/718 Cayman GTS 4.0 - with 6-speed manual gearbox (M-no. 480)	1 ea.
or		
V04015003M	⇒ Replacement engine (engine type DWAD) - 718 Boxster GTS 4.0/718 Cayman GTS 4.0 - with Porsche Doppelkupplung (PDK) (M-no. 250)	1 ea.

Additional parts required – all scopes:

V04014001AJ	⇒ Thatcham stickers (3 ea.) - Vehicle-specific stickers showing the allocation of vehicle identification number to engine number	1 ea.
99907283701	⇒ Hexagon-head bolt, AM10 x 1.5 x 55-PA - Rear-axle transverse strut	2 ea.
99907284001	⇒ Hexagon-head bolt, M10 x 35 - Rear-axle strut to body	2 ea.
90037815901	⇒ Hexagon-head bolt, AM8 x 60 - Anti-roll bar to rear-axle carrier	4 ea.
PAF105234	⇒ Cheese head bolt with multiple-tooth head, M10 x 52 - Drive shaft to transmission flange	12 ea.

9A740735700	⇒ Plate – Drive shaft to transmission flange	6 ea.
90091000303	⇒ Hexagon nut, M8 – Exhaust flange	6 ea.
N 10769401	⇒ Spring band clamp, 13.5 x 8.4 – Differential pressure hose	2 ea.
PAF906651	⇒ Cheese head bolt with multiple-tooth head, M10 x 1 x 29 – Flywheel	10 ea.
9A700846400	⇒ External hexalobular screw, BM12 x 1.5 x 55 – Transmission flange	6 ea.
90037824901	⇒ Hexagon-head bolt, AM10 x 55 – Transmission mount bracket to transmission housing	4 ea.
PAF008660	⇒ Hexagon nut, M10 – Engine carrier	3 ea.
99970765340	⇒ O-ring, 16.70 x 2.50N – Refrigerant line	1 ea.
99970755741	⇒ O-ring, 11.00 x 2.50NX – Refrigerant line	1 ea.

Additional parts required – Vehicle-specific/equipment-specific:

- **718 Spyder/718 Cayman GT4**

PAF007957	⇒ Hexagon self-clinching nut, M10 – Anti-roll bar to connecting link – 718 Spyder/718 Cayman GT4	2 ea.
982251263B	⇒ Seal – Exhaust flange – 718 Spyder/718 Cayman GT4	2 ea.
PAF909664	⇒ Hexagon collar nut, self-locking, M12 x 1.5 – Rear-axle camber and toe eccentric adjuster – 718 Spyder/718 Cayman GT4	4 ea.
PAF009242	⇒ Multiple-tooth flange screw, BM8 x 19 – Clutch pressure plate – 6-speed manual gearbox (M-no. 480)	6 ea.

Additional parts required – Vehicle-specific/equipment-specific:• **718 Boxster GTS 4.0/718 Cayman GTS 4.0**

99908412309	⇒ Hexagon nut, M10 – Anti-roll bar to connecting link – 718 Boxster GTS 4.0/718 Cayman GTS 4.0	2 ea.
982251263B	⇒ Seal – Exhaust flange – 718 Boxster GTS 4.0/718 Cayman GTS 4.0	2 ea.
99908444501	⇒ Lock nut, M12 x 1.5 – Rear-axle camber and toe eccentric adjuster – 718 Boxster GTS 4.0/718 Cayman GTS 4.0	4 ea.
PAF009242	⇒ Multiple-tooth flange screw, BM8 x 19 – Clutch pressure plate – 6-speed manual gearbox (M-no. 480)	6 ea.

Materials:

Required materials (usually already available at the Porsche dealer):

Part No.	Designation – Use	Qty.
00004330516	⇒ Antifreeze, 20 liter/ 5.28 gal container – Cooling system	As much as required (approx. 2 liter/ 0.53 gal required per vehicle)
00004330539	⇒ Klüberplus Gel grease, 100 g/ 3.53 oz tube – O-rings, coolant hoses	As much as required (approx. 10 g/ 0.35 ozrams required per vehicle)
00004330508	⇒ Optimol Paste TA grease, 100 g/ 3.53 oz tube – Wheel centring surface to wheel hub	As much as required (approx. 10 g/ 0.35 ozrams required per vehicle)
Other materials: Clean, lint-free cloth Cleaning agent (e.g. isopropanol)		

Required tools - Replacing engine

Tools:

Special tools:

Designation/Comment	Use
VAS 581 007 - Suction device for R1234yf 6096/2 Vacuum pump	Draining/filling coolant and bleeding the cooling system
9696 - Filling device	
VAS 6889 Spring Band Clamp Pliers	
VAS 6832 Master Gear unit elevating platform	Removing and installing engine
9454 - 9454 - Strapping belts	
9769 - 9769 - Retainer plate	
9769/1 - 9769/1 - Support	
9769/2 - 9769/2 - Support	
9822 - 9822 - Assembly tool	
VAS 6890 - Spring band clamp pliers	
VAS 6933 - Disassembly tool	
VAS 6100 - Workshop crane	Removing and mounting transmission
3033 - 3033 - Lifting tackle	Removing and mounting Porsche Doppelkupplung (PDK)
VAS 6123 - Tension belts	
VAS 6832/6 - Assembly fixture - Boxster	
VAS 6932 - Transport system	
VAS 6953 - Ring spanner insert, E18	
3176 - 3176 - Centring mandrel	Removing and installing clutch
VAS 6766 - Counter-hold tool	
T10172A - T10172A - Counter-hold tool	Removing and installing flywheel
9538/1 - 9538/1 - Toothed segment	Removing and installing flywheel DSG
9538/2 - 9538/2 - Bracket	
VAS 6942 - Torque/torque angle wrench, 20-400 Nm (15-296 ftlb.)	
VAS 6931 - Engine and gearbox jack	Removing and installing transmission mount
V.A.G 1331/13 - Ring wrench insert, a/f 10	Removing and installing rear-axle cross member

9827 - 9827 - Release tool	Checking the cooling system
T10007B - T10007B - Refractometer	
V.A.G 1274B - Cooling system tester	
9229/1 - 9229/1 - Puller hook	Suspension alignment, complete
9626 - 9626 - Insert for torque wrench	
9647 - 9647 - Hook wrench	
9730 - 9730 - Socket-wrench insert	
9847 - 9847 - Socket-wrench insert	
VAS 6826 - Steering wheel balance	
VAS 6918 - Quick-clamping unit	
VAS 6292 - Wheel-alignment system with Hawkeye sensors	Calibrating control unit for distance measuring sensor
V.A.G 1813F - Wheel alignment computer	
VAS 6430/1A - Adjustment device with reflector	
VAS 6430/3 - Mirror for adjustment device	
VAS 6190/2 - T-bar setting tool for ACC sensor	
9900 - PIWIS Tester 3	On-board diagnosis (OBD)
VAS 5908 Battery Charger, 90 A	

General tools:

- Torque wrench, 2 – 10 Nm (1.5 – 7.5 ftlb.), e.g. **VAG 1783 Torque wrench, 2-10 Nm (1.5-7.5 ftlb.)**
- Torque wrench, 6 – 50 Nm (4.5 – 37 ftlb.), e.g. **VAG 1331A Torque wrench, 6-50 Nm (4.5-37 ftlb.)**
- Torque wrench, 40 – 200 Nm (30 – 148 ftlb.), e.g. **VAG 1332 Torque wrench, 40-200 Nm (30-148 ftlb.)**
- Torque angle torque wrench, e.g. **9768 - Electronic torque wrench, 2 - 100 Nm/1.5 - 74 ftlb.**

Preparatory work - Replacing engine

Work Procedure: 1 Allocate the new engine to the vehicle and request vehicle-specific stickers and certificate from Porsche AG.



Information

Given that the engines are being replaced, the vehicle-specific stickers showing the allocation of vehicle identification number to engine number must be replaced by updated stickers showing the allocation of vehicle identification number to the **new** engine number.

As the production of the vehicle-specific stickers at Porsche AG takes approx. **4 working days plus shipping**, the vehicle-specific stickers (Thatcham) specified below should be requested as soon as a new engine has been allocated to a certain vehicle:

Part No.	Designation	Qty.
V04014001AJ	Thatcham sticker (contains 3 ea.)	1 ea.

To ensure that your request is processed quickly and efficiently, always use the following procedure when ordering the vehicle-specific stickers and certificate:

The vehicle-specific stickers must be requested from Porsche AG through your contact person responsible for parts enquiries at Porsche Cars North America via PRMS ticket:

PCNA_Parts_Support : Attn Joseph Boudreau

As soon as the new engine been received, inspected for any damages and allocated to the vehicle, send the following information and details via a PRMS ticket:

- **Vehicle identification number**
- **Exact mileage (km or miles) of the vehicle** (use last known mileage if vehicle is not yet available)
- **Engine number** of the **old** engine that was removed from the vehicle (can be found within PCSS)
- **Engine number** of the **new** engine, which will be installed in the vehicle
- Order no. (630...)
- **Delivery address** and **name of the contact person at the Porsche dealer** to whom the documents must be sent
- Campaign name **AMA4 Recall campaign – Replacing engine**

A certificate of engine replacement will be provided to customers separately by PCNA.

**Information**

The **engine number** is located on the crankcase towards the rear of the oil pan:

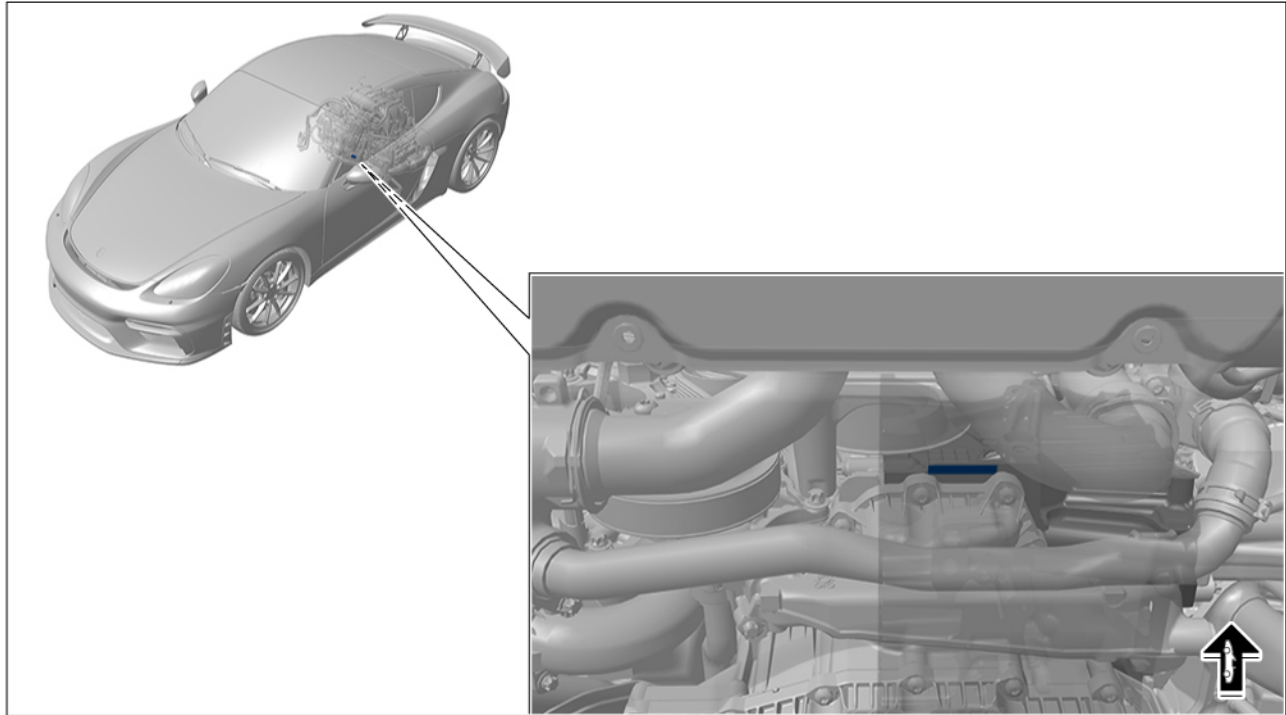

Engine number on crankcase

The engine number previously assigned to the VIN in the PAG systems is replaced with the new engine number in the PAG systems.

- 2 Before starting working on a vehicle, use the PIWIS Tester to read out the fault memories and create a Vehicle Analysis Log (VAL).
Mark the vehicle analysis log you have just created with the attribute "Initial VAL" and after carrying out the campaign, return it using the PIWIS Tester.

- 2.1 Connect a battery charger with a current rating of **at least 40 A**, e.g. **Battery charger 90 A** to the jump-start terminals and switch it on ⇒ *External power connection*.
- 2.2 Switch on the ignition using the original vehicle key.
For vehicles with "Porsche Entry & Drive", replace the control panel in the ignition lock with the original vehicle key, if necessary.
- 2.3 Connect **9900 - PIWIS Tester 3** to the vehicle communication module (VCI) via the **USB cable**. Then connect the communication module to the vehicle and switch on the PIWIS Tester.

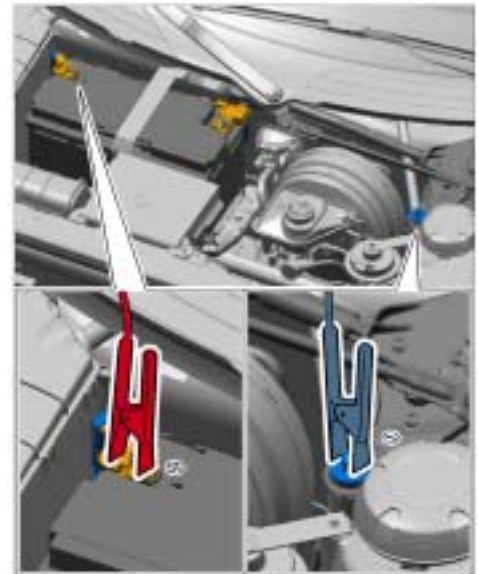

External power connection

Replacing engine

NOTICE

Engine/transmission unit lowered or inserted incorrectly.

- Risk of damage to engine/transmission unit
 - Cables and coolant hoses can be stretched and torn
- ⇒ Gradually lower or raise the engine using a jack.
- ⇒ Always check that all necessary cables were disconnected when lowering the engine/transmission unit.
- ⇒ Make sure that no cables or hoses are damaged when installing the engine/transmission unit.
- ⇒ Get one or two more persons to help.

WARNING

Danger of objects or loads falling down

- Risk of squashing or crushing
- ⇒ Secure components to prevent them from falling down.

**Information**

Please note that different preliminary and subsequent work is required, depending on the vehicle type and body shape.

For more information, refer to the relevant instructions in the Workshop Manuals.

- Work Procedure: 1 Drain engine oil from the engine to be replaced and from the oil filter on the engine to be replaced. Then install the completely empty oil filter and the previously used oil drain plugs back on the engine. For instructions, see:
⇒ *Workshop Manual '170117 Draining and filling engine oil'*
⇒ *Workshop Manual '173055 Changing oil filter'*
- 2 Remove engine/transmission unit.
For instructions on removing the engine/transmission unit, see ⇒ *Workshop Manual '100119 Removing and installing engine'*.

**Information**

After opening the refrigerant line connections, close them off immediately using stoppers.

- 3 Remove transmission from the engine to be replaced and place it on a suitable surface. Make sure that the PDK transmission is not set down on the oil pan. For instructions for manual transmission, see: ⇒ *Workshop Manual '343527 Removing and mounting transmission'*. For instructions for the PDK transmission, see: ⇒ *Workshop Manual '373427 Removing and mounting Porsche Doppelkupplung (PDK)'*.
- 4 Remove peripheral parts, e.g. clutch or flywheel (depending on vehicle equipment) from the engine to be replaced.
- 4.1 **On vehicles with manual transmission:** Remove clutch from the engine to be replaced.
⇒ *Workshop Manual '305019 Removing and installing clutch'*
- 4.2 Remove flywheel on the engine to be replaced.
⇒ *Workshop Manual '136019 Removing and installing flywheel'*
⇒ *Workshop Manual '136019 Removing and installing flywheel for double clutch transmission'*
- 5 Place the engine to be replaced on a suitable surface.

**Information**

The engines to be replaced must be scrapped by certified scrapping companies in the market, if not requested back by Porsche.

- 6 Remove transport packaging on the new engine.

- 7 Lift new engine out of the transport packaging and position on the elevating platform.
⇒ *Workshop Manual '1001IN Tools for removing/installing: units and working on assembly support'*
- 8 Verify and document new engine number on the repair order.
- 9 Install the previously removed peripheral parts to the new engine as described in the Workshop Manual.
 - 9.1 Install the flywheel to the new engine using new fastening screws.
⇒ *Workshop Manual '136019 Removing and installing flywheel'*
⇒ *Workshop Manual '136019 Removing and installing flywheel for double clutch transmission'*
 - 9.2 **On vehicles with manual transmission:** Install the clutch to the new engine using new fastening screws.
⇒ *Workshop Manual '305019 Removing and installing clutch'*

- 10 Before installing the engine/transmission unit, read off and note down the **IMA values of the new fuel injectors**.
To do this, remove the corresponding heat shield for ignition coils, then release and disconnect the plug connection on the injector.
Finally, connect and lock the relevant plug connection again and install the corresponding heat shield for ignition coils.

The IMA value can be read off the injector at the positions shown in the illustration ⇒ Fuel injector with individual parts and marking -4-.

- 4 – Code (IMA value for coding in the PIWIS Tester)

- 11 Mount the transmission on the new engine using new fastening screws.
For instructions for manual transmission, see: ⇒ *Workshop Manual '343527 Removing and mounting transmission'*.
For instructions for the PDK transmission, see: ⇒ *Workshop Manual '373427 Removing and mounting Porsche Doppelkupplung (PDK)'*.

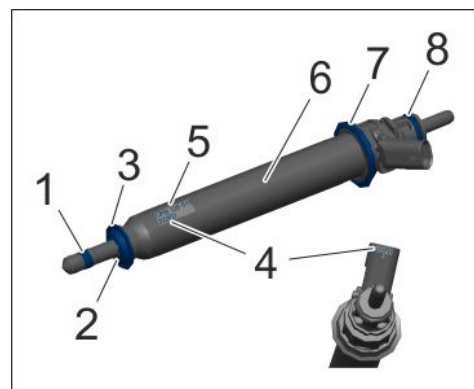

Fuel injector with individual parts and marking

- 12 Install engine/transmission unit.
For instructions on installing the engine/transmission unit, see ⇒ *Workshop Manual '100119 Removing and installing engine'*.
- 13 Perform on-board diagnosis using the PIWIS Tester.
 - 13.1 Assign the IMA values you wrote down earlier to the relevant cylinder under **Maintenance/repairs ⇒ Injectors ⇒ Install new injectors** on the **PIWIS Tester**.

- 13.2 Read out the fault memory and check any existing fault memory entries ⇒ *Workshop Manual '033500 Fault memory for on-board diagnosis'*.
 - 13.3 Delete fault memory entries and return to the control unit selection screen.
 - 13.4 Select the **DME control unit** in the control unit selection screen ('Overview' menu) and press •F12" ("Next") to confirm your selection.
 - 13.5 Call up the '**Drive links/checks**' menu.
 - 13.6 Select the '**Adaptations**' function and press •F12" ("Next") to confirm your selection.
 - 13.7 Select **all** functions listed under 'Adaptations' **individually** and perform them **one after the other**.
Then press •F12" ("Next") and •F11" ("Back") to return to the control unit selection screen.
 - 13.8 Read out the engine-oil level using the PIWIS Tester and add engine oil if necessary ⇒ *Workshop Manual '170101 Checking engine-oil level'*.
 - 13.9 Switch off ignition.
- 14 Perform suspension alignment and make adjustments.
For instructions, see:
⇒ *Workshop Manual '449503 Suspension alignment, complete'*
⇒ *Workshop Manual '4495TW Adjustment values for suspension alignment'*
 - 15 After correcting the wheel alignment values, carry out the following work.
 - 15.1 Calibrate steering-angle sensor ⇒ *Workshop Manual '456005 Initialising and calibrating PSM steering-angle sensor'*.
 - 15.2 Calibrating PASM
 - 15.2.1 Select the **PASM control unit** in the control unit selection screen ('Overview' menu) and press •F12" ('Next') to confirm your selection.
 - 15.2.2 Once the PASM control unit has been found and is displayed in the overview, select the '**Maintenance/repairs**' menu.
 - 15.2.3 Select 'Calibration' in the menu and press •F12" ('Next') to confirm. Follow the instructions on the PIWIS Tester and complete calibration.
 - 15.3 Teach steering lock settings for the power-steering gear ⇒ *Workshop Manual '489025 Power-steering gear: Teaching steering lock settings'*.
 - 15.4 If installed: Calibrate front camera ⇒ *Workshop Manual '963855 Replacing front camera'*.
 - 15.5 If installed: Calibrate control unit for distance measuring sensor (ACC sensor) ⇒ *Workshop Manual '278515 Adjusting control unit for distance measuring sensor'*.
 - 15.6 Adjust the headlights ⇒ *Workshop Manual '941516 Adjusting headlights'*.

Concluding work - Replacing engine



Information

Once the engine in the vehicle has been replaced, the stickers affixed to the vehicle showing the vehicle identification number and engine number must be replaced with updated stickers showing the engine number of the **newly installed engine**.

- 1 Affix new vehicle identification stickers over the stickers showing the allocation of vehicle identification number to engine number.

The stickers must be affixed at the following positions on the **right-hand side of the vehicle in direction of travel**:

- Lid, front right inside
- A-pillar, front right
- Lid, rear right inside (only for 718 Spyder: lid, top rear)

- 1.1 Check that the vehicle identification number and engine number shown on the **new** stickers match the vehicle identification number of the vehicle and the engine number of the **newly installed engine**.

- 1.2 Affix new sticker over existing sticker on **front lid**.

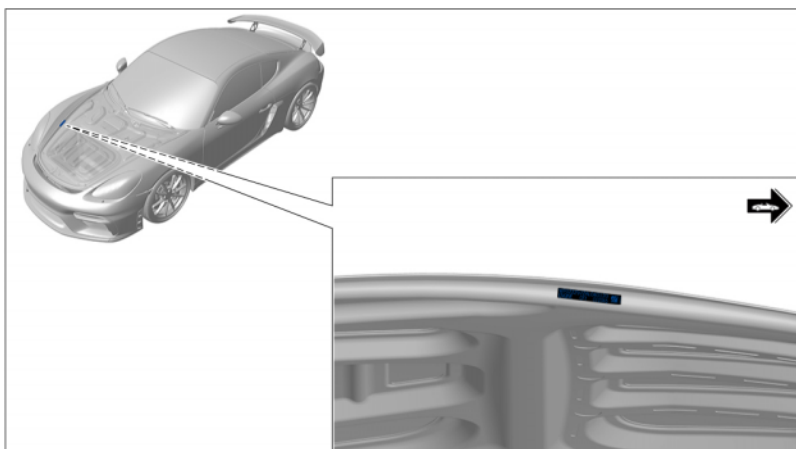

Sticker on lid, front right

- 1.2.1 Clean the sticker ⇒ *Sticker on lid, front right* affixed to the front lid using a suitable cleaning agent (e.g. isopropanol) and then rub it dry with a clean, lint-free cloth.
- 1.2.2 Affix a new sticker over the existing sticker in such a way that the existing sticker is **covered exactly** by the new sticker. When affixing the new sticker, make sure that the new sticker is affixed with the **same text alignment** as the existing sticker.
- 1.2.3 Close the front lid.

- 1.3 Affix new sticker over existing sticker on the **front right A-pillar**.

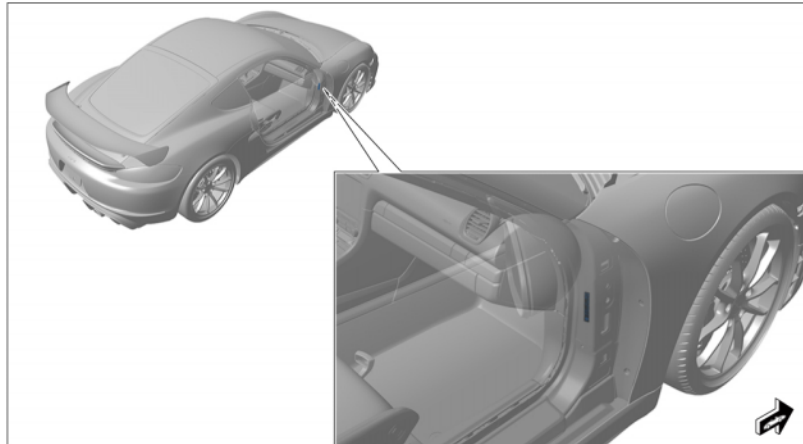

Sticker on A-pillar, front right

- 1.3.1 Open front right door.
- 1.3.2 Clean the sticker \Rightarrow *Sticker on A-pillar, front right* affixed to the A-pillar using a suitable cleaning agent (e.g. isopropanol) and then rub it dry with a clean, lint-free cloth.
- 1.3.3 Affix a new sticker over the existing sticker in such a way that the existing sticker is **covered exactly** by the new sticker. When affixing the new sticker, make sure that the new sticker is affixed with the **same text alignment** as the existing sticker.
- 1.3.4 Close front right door.
- 1.4 Affix new sticker over existing sticker on the **rear right lid**.

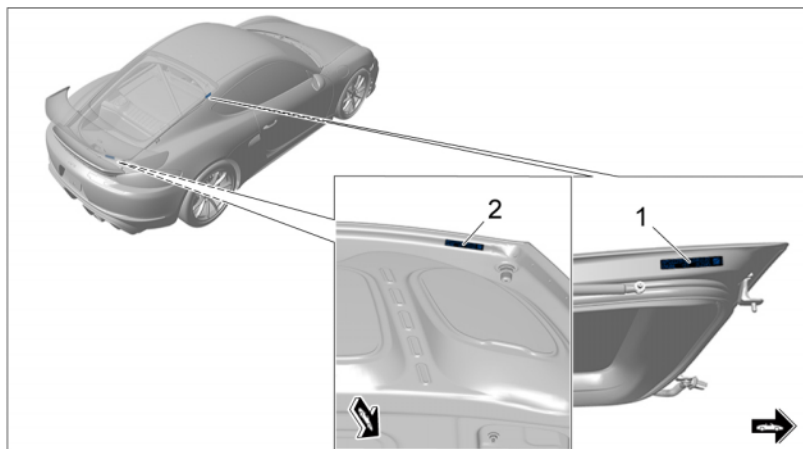

Sticker on rear lid

- 1.4.1 Open the luggage compartment lid.

- 1.4.2 Clean the sticker ⇒ *Sticker on rear lid* affixed to the side of the rear right side of the lid ⇒ *Sticker on rear lid-1-* (except 718 Spyder ⇒ *Sticker on rear lid-2-*) using a suitable cleaning agent (e.g. isopropanol) and then rub it dry with a clean, lint-free cloth.
 - 1.4.3 Affix a new sticker over the existing sticker in such a way that the existing sticker is **covered exactly** by the new sticker. When affixing the new sticker, make sure that the new sticker is affixed with the **same text alignment** as the existing sticker.
 - 1.4.4 Close the luggage compartment lid.
- 2 Carry out an extended test drive according to the criteria for a test drive during the sales check. Observe the following specifications during the extended test drive:
 - Only allow service advisors or workshop staff with the relevant qualification and experience (e.g. workshop managers) to test-drive the vehicle.
 - The vehicle should be driven for a distance of approx. **12 miles** with a **normal** driving profile.
 - **Do not exceed a maximum engine speed of 6,500 rpm.**
 - Check the vehicle for unusual handling behavior, vibrations and noise.
 On vehicles with PDK transmission, also pay particular attention to the following points:
 - Only drive with the selector lever in position "D".
 - **Do not drive in kickdown mode** in order to ensure that a maximum engine speed of 6,500 rpm is not exceeded.
 - 3 After the test drive, let the vehicle cool down until the coolant temperature is max. 60 °C. Then check the coolant level and engine-oil level and add coolant or engine oil as required.
 - 4 Create vehicle analysis log (VAL) using the PIWIS Tester.
Mark the vehicle analysis log you have just created with the attribute "Final VAL" and after carrying out the campaign, return it using the PIWIS Tester.
 - 5 Disconnect the PIWIS Tester from the vehicle.
 - 6 Switch off and disconnect the battery charger.
 - 7 Raise the vehicle on a lifting platform again and check the engine for leaks or other problems.
 - 8 Enter the campaign in the Warranty and Maintenance booklet.

Warranty processing

- Scope 1: **Replacing engine**
- 718 Cayman GT4
 - With 6-speed manual gearbox (M-no. 480)

Working time:

Replacing engine

Labor time: **1567 TU**

Includes:

- Removing and installing engine/transmission unit
- Removing and mounting transmission
- Removing engine to be replaced and mounting new engine
- Removing peripheral parts on engine to be replaced and installing them on new engine
- Checking engine-oil level
- Connecting and disconnecting battery charger (several times)
- Connecting and disconnecting PIWIS Tester (several times)
- Performing on-board diagnosis using the PIWIS Tester
- Performing suspension alignment and adjusting the vehicle
- Calibrating steering-angle sensor and teaching limit stops
- Calibrating front camera (if installed)
- Replacing vehicle identification stickers
- Carrying out an extended test drive

Parts required:

V04015003J	Replacement engine (engine type DWAA/DKDA) - 718 Cayman GT4 - with 6-speed manual gearbox (M-no. 480)	1 ea.
V04014001AJ	Thatcham stickers	1 ea.
99907283701	Hexagon-head bolt, AM10 x 1.5 x 55-PA	2 ea.
99907284001	Hexagon-head bolt, M10 x 35	2 ea.
90037815901	Hexagon-head bolt AM8 x 60	4 ea.
PAF007957	Hexagon self-clinching nut, M10	2 ea.
PAF105234	Cheese head bolt with multiple-tooth head, M10 x 52	12 ea.
9A740735700	Plate	6 ea.
982251263B	Seal	2 ea.
90091000303	Hexagon nut, M8	6 ea.
N 10769401	Spring band clamp, 13.5 x 8.4	2 ea.
PAF009242	Multiple-tooth flange screw, BM8 x 19	6 ea.
PAF906651	Cheese head bolt with multiple-tooth head, M10 x 1 x 29	10 ea.
9A700846400	External hexalobular screw, BM12 x 1.5 x 55	6 ea.

90037824901	Hexagon-head bolt, AM10 x 55	4 ea.
PAF008660	Hexagon nut, M10	3 ea.
99970765340	O-ring 16.70 x 2.50N	1 ea.
99970755741	O-ring 11.00 x 2.50NX	1 ea.
PAF909664	Hexagon collar nut, self-locking, M12 x 1.5	4 ea.
Materials required:		
00004330516	Antifreeze (20 liter/ 5.28 gal container)	0.1 ea. (= approx. 2 liter/ 0.53 gal)
00004330539	Klüberplus Gel grease (100 g/ 3.53 oz tube)	0.1 ea. (= approx. 10 g/ 0.35 oz)
00004330508	Optimol Paste TA grease (100 g/ 3.53 oz tube)	0.1 ea. (= approx. 10 g/ 0.35 oz)
⇒ Damage Code AMA4 099 000 2		

Scope 2:

Replacing engine

- 718 Spyder
- With 6-speed manual gearbox (M-no. 480)

Working time:		
Replacing engine		Labor time: 1527 TU
Includes:	Removing and installing engine/transmission unit Removing and mounting transmission Removing engine to be replaced and mounting new engine Removing peripheral parts on engine to be replaced and installing them on new engine Checking engine-oil level Connecting and disconnecting battery charger (several times) Connecting and disconnecting PIWIS Tester (several times) Performing on-board diagnosis using the PIWIS Tester Performing suspension alignment and adjusting the vehicle Calibrating steering-angle sensor and teaching limit stops Calibrating front camera (if installed) Replacing vehicle identification stickers Carrying out an extended test drive	

Parts required:

V04015003J	Replacement engine (engine type DWAA/DKDA) - 718 Spyder - with 6-speed manual gearbox (M-no. 480)	1 ea.
V04014001AJ	Thatcham stickers	1 ea.
99907283701	Hexagon-head bolt, AM10 x 1.5 x 55-PA	2 ea.
99907284001	Hexagon-head bolt, M10 x 35	2 ea.
90037815901	Hexagon-head bolt AM8 x 60	4 ea.
PAF007957	Hexagon self-clinching nut, M10	2 ea.
PAF105234	Cheese head bolt with multiple-tooth head, M10 x 52	12 ea.
9A740735700	Plate	6 ea.
982251263B	Seal	2 ea.
90091000303	Hexagon nut, M8	6 ea.
N 10769401	Spring band clamp, 13.5 x 8.4	2 ea.
PAF009242	Multiple-tooth flange screw, BM8 x 19	6 ea.
PAF906651	Cheese head bolt with multiple-tooth head, M10 x 1 x 29	10 ea.
9A700846400	External hexalobular screw, BM12 x 1.5 x 55	6 ea.
90037824901	Hexagon-head bolt, AM10 x 55	4 ea.
PAF008660	Hexagon nut, M10	3 ea.
99970765340	O-ring 16.70 x 2.50N	1 ea.
99970755741	O-ring 11.00 x 2.50NX	1 ea.
PAF909664	Hexagon collar nut, self-locking, M12 x 1.5	4 ea.

Materials required:

00004330516	Antifreeze (20 liter/ 5.28 gal container)	0.1 ea. (= approx. 2 liter/ 0.53 gal)
00004330539	Klüberplus Gel grease (100 g/ 3.53 oz tube)	0.1 ea. (= approx. 10 g/ 0.35 oz)
00004330508	Optimol Paste TA grease (100 g/ 3.53 oz tube)	0.1 ea. (= approx. 10 g/ 0.35 oz)

⇒ Damage Code AMA4 099 000 2

Scope 3: **Replacing engine**

- 718 Boxster GTS 4.0
- With 6-speed manual gearbox (M-no. 480)

Working time:

Replacing engine

Labor time: **1485 TU**

- Includes:
- Removing and installing engine/transmission unit
 - Removing and mounting transmission
 - Removing engine to be replaced and mounting new engine
 - Removing peripheral parts on engine to be replaced and installing them on new engine
 - Checking engine-oil level
 - Connecting and disconnecting battery charger (several times)
 - Connecting and disconnecting PIWIS Tester (several times)
 - Performing on-board diagnosis using the PIWIS Tester
 - Performing suspension alignment and adjusting the vehicle
 - Calibrating steering-angle sensor and teaching limit stops
 - Calibrating PASM
 - Calibrating front camera (if installed)
 - Replacing vehicle identification stickers
 - Carrying out an extended test drive

Parts required:

V04015003L	Replacement engine (engine type DWAC/DKDC) - 718 Boxster GTS 4.0 - with 6-speed manual gearbox (M-no. 480)	1 ea.
V04014001AJ	Thatcham stickers	1 ea.
99907283701	Hexagon-head bolt, AM10 x 1.5 x 55-PA	2 ea.
99907284001	Hexagon-head bolt, M10 x 35	2 ea.
90037815901	Hexagon-head bolt AM8 x 60	4 ea.
99908412309	Hexagon nut, M10	2 ea.
PAF105234	Cheese head bolt with multiple-tooth head, M10 x 52	12 ea.
9A740735700	Plate	6 ea.
982251263B	Seal	2 ea.
90091000303	Hexagon nut, M8	6 ea.
N 10769401	Spring band clamp, 13.5 x 8.4	2 ea.
PAF009242	Multiple-tooth flange screw, BM8 x 19	6 ea.

PAF906651	Cheese head bolt with multiple-tooth head, M10 x 1 x 29	10 ea.
9A700846400	External hexalobular screw, BM12 x 1.5 x 55	6 ea.
90037824901	Hexagon-head bolt, AM10 x 55	4 ea.
PAF008660	Hexagon nut, M10	3 ea.
99970765340	O-ring 16.70 x 2.50N	1 ea.
99970755741	O-ring 11.00 x 2.50NX	1 ea.
99908444501	Lock nut, M12 x 1.5	4 ea.
Materials required:		
00004330516	Antifreeze (20 liter/ 5.28 gal container)	0.1 ea. (= approx. 2 liter/ 0.53 gal)
00004330539	Klüberplus Gel grease (100 g/ 3.53 oz tube)	0.1 ea. (= approx. 10 g/ 0.35 oz)
00004330508	Optimol Paste TA grease (100 g/ 3.53 oz tube)	0.1 ea. (= approx. 10 g/ 0.35 oz)
⇒ Damage Code AMA4 099 000 2		

Scope 4:

Replacing engine

- 718 Cayman GTS 4.0
- With 6-speed manual gearbox (M-no. 480)

Working time:

Replacing engine

Labor time: **1525 TU**

Includes:

- Removing and installing engine/transmission unit
- Removing and mounting transmission
- Removing engine to be replaced and mounting new engine
- Removing peripheral parts on engine to be replaced and installing them on new engine
- Checking engine-oil level
- Connecting and disconnecting battery charger (several times)
- Connecting and disconnecting PIWIS Tester (several times)
- Performing on-board diagnosis using the PIWIS Tester
- Performing suspension alignment and adjusting the vehicle
- Calibrating steering-angle sensor and teaching limit stops
- Calibrating PASM
- Calibrating front camera (if installed)

Replacing vehicle identification stickers
 Carrying out an extended test drive

Parts required:

V04015003L	Replacement engine (engine type DWAC/DKDC) - 718 Boxster GTS 4.0 - with 6-speed manual gearbox (M-no. 480)	1 ea.
V04014001AJ	Thatcham stickers	1 ea.
99907283701	Hexagon-head bolt, AM10 x 1.5 x 55-PA	2 ea.
99907284001	Hexagon-head bolt, M10 x 35	2 ea.
90037815901	Hexagon-head bolt AM8 x 60	4 ea.
99908412309	Hexagon nut, M10	2 ea.
PAF105234	Cheese head bolt with multiple-tooth head, M10 x 52	12 ea.
9A740735700	Plate	6 ea.
982251263B	Seal	2 ea.
90091000303	Hexagon nut, M8	6 ea.
N 10769401	Spring band clamp, 13.5 x 8.4	2 ea.
PAF009242	Multiple-tooth flange screw, BM8 x 19	6 ea.
PAF906651	Cheese head bolt with multiple-tooth head, M10 x 1 x 29	10 ea.
9A700846400	External hexalobular screw, BM12 x 1.5 x 55	6 ea.
90037824901	Hexagon-head bolt, AM10 x 55	4 ea.
PAF008660	Hexagon nut, M10	3 ea.
99970765340	O-ring 16.70 x 2.50N	1 ea.
99970755741	O-ring 11.00 x 2.50NX	1 ea.
99908444501	Lock nut, M12 x 1.5	4 ea.

Materials required:

00004330516	Antifreeze (20 liter/ 5.28 gal container)	0.1 ea. (= approx. 2 liter/ 0.53 gal)
00004330539	Klüberplus Gel grease (100 g/ 3.53 oz tube)	0.1 ea. (= approx. 10 g/ 0.35 oz)

00004330508	Optimol Paste TA grease (100 g/ 3.53 oz tube)	0.1 ea. (= approx. 10 g/ 0.35 oz)
-------------	---	--------------------------------------

⇒ **Damage Code AMA4 099 000 2**

Scope 5:

Replacing engine

- 718 Cayman GT4
- With Porsche Doppelkupplung (PDK) (M-no. 250)

Working time:

Replacing engine

Labor time: **1548 TU**

Includes:

- Removing and installing engine/transmission unit
- Removing and mounting transmission
- Removing engine to be replaced and mounting new engine
- Removing peripheral parts on engine to be replaced and installing them on new engine
- Checking engine-oil level
- Connecting and disconnecting battery charger (several times)
- Connecting and disconnecting PIWIS Tester (several times)
- Performing on-board diagnosis using the PIWIS Tester
- Performing suspension alignment and adjusting the vehicle
- Calibrating steering-angle sensor and teaching limit stops
- Calibrating front camera (if installed)
- Replacing vehicle identification stickers
- Carrying out an extended test drive

Parts required:

V04015003K	Replacement engine (engine type DWAB) - 718 Cayman GT4 - with Porsche Doppelkupplung (PDK) (M-no. 250)	1 ea.
V04014001AJ	Thatcham stickers	1 ea.
99907283701	Hexagon-head bolt, AM10 x 1.5 x 55-PA	2 ea.
99907284001	Hexagon-head bolt, M10 x 35	2 ea.
90037815901	Hexagon-head bolt AM8 x 60	4 ea.
PAF007957	Hexagon self-clinching nut, M10	2 ea.
PAF105234	Cheese head bolt with multiple-tooth head, M10 x 52	12 ea.

9A740735700	Plate	6 ea.
982251263B	Seal	2 ea.
90091000303	Hexagon nut, M8	6 ea.
N 10769401	Spring band clamp, 13.5 x 8.4	2 ea.
PAF906651	Cheese head bolt with multiple-tooth head, M10 x 1 x 29	10 ea.
9A700846400	External hexalobular screw, BM12 x 1.5 x 55	6 ea.
90037824901	Hexagon-head bolt, AM10 x 55	4 ea.
PAF008660	Hexagon nut, M10	3 ea.
99970765340	O-ring 16.70 x 2.50N	1 ea.
99970755741	O-ring 11.00 x 2.50NX	1 ea.
PAF909664	Hexagon collar nut, self-locking, M12 x 1.5	4 ea.
Materials required:		
00004330516	Antifreeze (20 liter/ 5.28 gal container)	0.1 ea. (= approx. 2 liter/ 0.53 gal)
00004330539	Klüberplus Gel grease (100 g/ 3.53 oz tube)	0.1 ea. (= approx. 10 g/ 0.35 oz)
00004330508	Optimol Paste TA grease (100 g/ 3.53 oz tube)	0.1 ea. (= approx. 10 g/ 0.35 oz)
⇒ Damage Code AMA4 099 000 2		

Scope 6:

Replacing engine

- 718 Spyder
- With Porsche Doppelkupplung (PDK) (M-no. 250)

Working time:	
Replacing engine	Labor time: 1508 TU
Includes:	Removing and installing engine/transmission unit Removing and mounting transmission Removing engine to be replaced and mounting new engine Removing peripheral parts on engine to be replaced and installing them on new engine Checking engine-oil level Connecting and disconnecting battery charger (several times) Connecting and disconnecting PIWIS Tester (several times)

Performing on-board diagnosis using the PIWIS Tester
 Performing suspension alignment and adjusting the vehicle
 Calibrating steering-angle sensor and teaching limit stops
 Calibrating front camera (if installed)
 Replacing vehicle identification stickers
 Carrying out an extended test drive

Parts required:

V04015003K	Replacement engine (engine type DWAB) - 718 Spyder - with Porsche Doppelkupplung (PDK) (M-no. 250)	1 ea.
V04014001AJ	Thatcham stickers	1 ea.
99907283701	Hexagon-head bolt, AM10 x 1.5 x 55-PA	2 ea.
99907284001	Hexagon-head bolt, M10 x 35	2 ea.
90037815901	Hexagon-head bolt AM8 x 60	4 ea.
PAF007957	Hexagon self-clinching nut, M10	2 ea.
PAF105234	Cheese head bolt with multiple-tooth head, M10 x 52	12 ea.
9A740735700	Plate	6 ea.
982251263B	Seal	2 ea.
90091000303	Hexagon nut, M8	6 ea.
N 10769401	Spring band clamp, 13.5 x 8.4	2 ea.
PAF906651	Cheese head bolt with multiple-tooth head, M10 x 1 x 29	10 ea.
9A700846400	External hexalobular screw, BM12 x 1.5 x 55	6 ea.
90037824901	Hexagon-head bolt, AM10 x 55	4 ea.
PAF008660	Hexagon nut, M10	3 ea.
99970765340	O-ring 16.70 x 2.50N	1 ea.
99970755741	O-ring 11.00 x 2.50NX	1 ea.
PAF909664	Hexagon collar nut, self-locking, M12 x 1.5	4 ea.

Materials required:

00004330516	Antifreeze (20 liter/ 5.28 gal container)	0.1 ea. (= approx. 2 liter/ 0.53 gal)
-------------	---	--

00004330539	Klüberplus Gel grease (100 g/ 3.53 oz tube)	0.1 ea. (= approx. 10 g/ 0.35 oz)
00004330508	Optimol Paste TA grease (100 g/ 3.53 oz tube)	0.1 ea. (= approx. 10 g/ 0.35 oz)
⇒ Damage Code AMA4 099 000 2		

Scope 7:

Replacing engine

- 718 Boxster GTS 4.0
- With Porsche Doppelkupplung (PDK) (M-no. 250)

Working time:		
Replacing engine		Labor time: 1466 TU
Includes:	Removing and installing engine/transmission unit Removing and mounting transmission Removing engine to be replaced and mounting new engine Removing peripheral parts on engine to be replaced and installing them on new engine Checking engine-oil level Connecting and disconnecting battery charger (several times) Connecting and disconnecting PIWIS Tester (several times) Performing on-board diagnosis using the PIWIS Tester Performing suspension alignment and adjusting the vehicle Calibrating steering-angle sensor and teaching limit stops Calibrating PASM Calibrating front camera (if installed) Replacing vehicle identification stickers Carrying out an extended test drive	
Parts required:		
V04015003M	Replacement engine (engine type DWAD) - 718 Boxster GTS 4.0 - with Porsche Doppelkupplung (PDK) (M-no. 250)	1 ea.
V04014001AJ	Thatcham stickers	1 ea.
99907283701	Hexagon-head bolt, AM10 x 1.5 x 55-PA	2 ea.
99907284001	Hexagon-head bolt, M10 x 35	2 ea.
90037815901	Hexagon-head bolt AM8 x 60	4 ea.

99908412309	Hexagon nut, M10	2 ea.
PAF105234	Cheese head bolt with multiple-tooth head, M10 x 52	12 ea.
9A740735700	Plate	6 ea.
982251263B	Seal	2 ea.
90091000303	Hexagon nut, M8	6 ea.
N 10769401	Spring band clamp, 13.5 x 8.4	2 ea.
PAF906651	Cheese head bolt with multiple-tooth head, M10 x 1 x 29	10 ea.
9A700846400	External hexalobular screw, BM12 x 1.5 x 55	6 ea.
90037824901	Hexagon-head bolt, AM10 x 55	4 ea.
PAF008660	Hexagon nut, M10	3 ea.
99970765340	O-ring 16.70 x 2.50N	1 ea.
99970755741	O-ring 11.00 x 2.50NX	1 ea.
99908444501	Lock nut, M12 x 1.5	4 ea.
Materials required:		
00004330516	Antifreeze (20 liter/ 5.28 gal container)	0.1 ea. (= approx. 2 liter/ 0.53 gal)
00004330539	Klüberplus Gel grease (100 g/ 3.53 oz tube)	0.1 ea. (= approx. 10 g/ 0.35 oz)
00004330508	Optimol Paste TA grease (100 g/ 3.53 oz tube)	0.1 ea. (= approx. 10 g/ 0.35 oz)
⇒ Damage Code AMA4 099 000 2		

Scope 8: **Replacing engine**

- 718 Cayman GTS 4.0
- With Porsche Doppelkupplung (PDK) (M-no. 250)

Working time:

Replacing engine

Labor time: **1506 TU**

- Includes:
- Removing and installing engine/transmission unit
 - Removing and mounting transmission
 - Removing engine to be replaced and mounting new engine
 - Removing peripheral parts on engine to be replaced and installing them on new engine
 - Checking engine-oil level
 - Connecting and disconnecting battery charger (several times)
 - Connecting and disconnecting PIWIS Tester (several times)
 - Performing on-board diagnosis using the PIWIS Tester
 - Performing suspension alignment and adjusting the vehicle
 - Calibrating steering-angle sensor and teaching limit stops
 - Calibrating PASM
 - Calibrating front camera (if installed)
 - Replacing vehicle identification stickers
 - Carrying out an extended test drive

Parts required:

V04015003M	Replacement engine (engine type DWAD) - 718 Cayman GTS 4.0 - with Porsche Doppelkupplung (PDK) (M-no. 250)	1 ea.
V04014001AJ	Thatcham stickers	1 ea.
99907283701	Hexagon-head bolt, AM10 x 1.5 x 55-PA	2 ea.
99907284001	Hexagon-head bolt, M10 x 35	2 ea.
90037815901	Hexagon-head bolt AM8 x 60	4 ea.
99908412309	Hexagon nut, M10	2 ea.
PAF105234	Cheese head bolt with multiple-tooth head, M10 x 52	12 ea.
9A740735700	Plate	6 ea.
982251263B	Seal	2 ea.
90091000303	Hexagon nut, M8	6 ea.
N 10769401	Spring band clamp, 13.5 x 8.4	2 ea.
PAF906651	Cheese head bolt with multiple-tooth head, M10 x 1 x 29	10 ea.
9A700846400	External hexalobular screw, BM12 x 1.5 x 55	6 ea.

90037824901	Hexagon-head bolt, AM10 x 55	4 ea.
PAF008660	Hexagon nut, M10	3 ea.
99970765340	O-ring 16.70 x 2.50N	1 ea.
99970755741	O-ring 11.00 x 2.50NX	1 ea.
99908444501	Lock nut, M12 x 1.5	4 ea.
Materials required:		
00004330516	Antifreeze (20 liter/ 5.28 gal container)	0.1 ea. (= approx. 2 liter/ 0.53 gal)
00004330539	Klüberplus Gel grease (100 g/ 3.53 oz tube)	0.1 ea. (= approx. 10 g/ 0.35 oz)
00004330508	Optimol Paste TA grease (100 g/ 3.53 oz tube)	0.1 ea. (= approx. 10 g/ 0.35 oz)
⇒ Damage Code AMA4 099 000 2		

Scope 9:

Replacing engine

- 718 Boxster GTS 4.0
- With Porsche Doppelkupplung (PDK) (M-no. 250)
- With adaptive cruise control (ACC) (M-no. 456)

Working time:

Replacing engine

Labor time: **1494 TU**

Includes:

- Removing and installing engine/transmission unit
- Removing and mounting transmission
- Removing engine to be replaced and mounting new engine
- Removing peripheral parts on engine to be replaced and installing them on new engine
- Checking engine-oil level
- Connecting and disconnecting battery charger (several times)
- Connecting and disconnecting PIWIS Tester (several times)
- Performing on-board diagnosis using the PIWIS Tester
- Performing suspension alignment and adjusting the vehicle
- Calibrating steering-angle sensor and teaching limit stops
- Calibrating PASM
- Calibrating front camera (if installed)
- Calibrating control unit for distance measuring sensor
- Replacing vehicle identification stickers
- Carrying out an extended test drive

Parts required:

V04015003M	Replacement engine (engine type DWAD) - 718 Boxster GTS 4.0 - with Porsche Doppelkupplung (PDK) (M-no. 250)	1 ea.
V04014001AJ	Thatcham stickers	1 ea.
99907283701	Hexagon-head bolt, AM10 x 1.5 x 55-PA	2 ea.
99907284001	Hexagon-head bolt, M10 x 35	2 ea.
90037815901	Hexagon-head bolt AM8 x 60	4 ea.
99908412309	Hexagon nut, M10	2 ea.
PAF105234	Cheese head bolt with multiple-tooth head, M10 x 52	12 ea.
9A740735700	Plate	6 ea.
982251263B	Seal	2 ea.
90091000303	Hexagon nut, M8	6 ea.
N 10769401	Spring band clamp, 13.5 x 8.4	2 ea.
PAF906651	Cheese head bolt with multiple-tooth head, M10 x 1 x 29	10 ea.
9A700846400	External hexalobular screw, BM12 x 1.5 x 55	6 ea.
90037824901	Hexagon-head bolt, AM10 x 55	4 ea.
PAF008660	Hexagon nut, M10	3 ea.
99970765340	O-ring 16.70 x 2.50N	1 ea.
99970755741	O-ring 11.00 x 2.50NX	1 ea.
99908444501	Lock nut, M12 x 1.5	4 ea.

Materials required:

00004330516	Antifreeze (20 liter/ 5.28 gal container)	0.1 ea. (= approx. 2 liter/ 0.53 gal)
00004330539	Klüberplus Gel grease (100 g/ 3.53 oz tube)	0.1 ea. (= approx. 10 g/ 0.35 oz)
00004330508	Optimol Paste TA grease (100 g/ 3.53 oz tube)	0.1 ea. (= approx. 10 g/ 0.35 oz)

⇒ Damage Code AMA4 099 000 2

Scope 10: **Replacing engine**

- 718 Cayman GTS 4.0
- With Porsche Doppelkupplung (PDK) (M-no. 250)
- With adaptive cruise control (ACC) (M-no. 456)

Working time:

Replacing engine

Labor time: **1534 TU**

Includes:

- Removing and installing engine/transmission unit
- Removing and mounting transmission
- Removing engine to be replaced and mounting new engine
- Removing peripheral parts on engine to be replaced and installing them on new engine
- Checking engine-oil level
- Connecting and disconnecting battery charger (several times)
- Connecting and disconnecting PIWIS Tester (several times)
- Performing on-board diagnosis using the PIWIS Tester
- Performing suspension alignment and adjusting the vehicle
- Calibrating steering-angle sensor and teaching limit stops
- Calibrating PASM
- Calibrating front camera (if installed)
- Calibrating control unit for distance measuring sensor
- Replacing vehicle identification stickers
- Carrying out an extended test drive

Parts required:

V04015003M	Replacement engine (engine type DWAD) - 718 Cayman GTS 4.0 - with Porsche Doppelkupplung (PDK) (M-no. 250)	1 ea.
V04014001AJ	Thatcham stickers	1 ea.
99907283701	Hexagon-head bolt, AM10 x 1.5 x 55-PA	2 ea.
99907284001	Hexagon-head bolt, M10 x 35	2 ea.
90037815901	Hexagon-head bolt AM8 x 60	4 ea.
99908412309	Hexagon nut, M10	2 ea.
PAF105234	Cheese head bolt with multiple-tooth head, M10 x 52	12 ea.

9A740735700	Plate	6 ea.
982251263B	Seal	2 ea.
90091000303	Hexagon nut, M8	6 ea.
N 10769401	Spring band clamp, 13.5 x 8.4	2 ea.
PAF906651	Cheese head bolt with multiple-tooth head, M10 x 1 x 29	10 ea.
9A700846400	External hexalobular screw, BM12 x 1.5 x 55	6 ea.
90037824901	Hexagon-head bolt, AM10 x 55	4 ea.
PAF008660	Hexagon nut, M10	3 ea.
99970765340	O-ring 16.70 x 2.50N	1 ea.
99970755741	O-ring 11.00 x 2.50NX	1 ea.
99908444501	Lock nut, M12 x 1.5	4 ea.
Materials required:		
00004330516	Antifreeze (20 liter/ 5.28 gal container)	0.1 ea. (= approx. 2 liter/ 0.53 gal)
00004330539	Klüberplus Gel grease (100 g/ 3.53 oz tube)	0.1 ea. (= approx. 10 g/ 0.35 oz)
00004330508	Optimol Paste TA grease (100 g/ 3.53 oz tube)	0.1 ea. (= approx. 10 g/ 0.35 oz)
⇒ Damage Code AMA4 099 000 2		

Important Notice: Technical Bulletins issued by Porsche Cars North America, Inc. are intended only for use by professional automotive technicians who have attended Porsche service training courses. They are written to inform those technicians of conditions that may occur on some Porsche vehicles, or to provide information that could assist in the proper servicing of a vehicle. Porsche special tools may be necessary in order to perform certain operations identified in these bulletins. Use of tools and procedures other than those Porsche recommends in these bulletins may be detrimental to the safe operation of your vehicle, and may endanger the people working on it. Properly trained Porsche technicians have the equipment, tools, safety instructions, and know-how to do the job properly and safely. Part numbers listed in these bulletins are for reference only. The work procedures updated electronically in the Porsche PIWIS diagnostic and testing device take precedence and, in the event of a discrepancy, the work procedures in the PIWIS Tester are the ones that must be followed.

© 2021 Porsche Cars North America, Inc.