

PREVOST

Instruction Sheet

IS-19037A

PREVOST DRIVER ASSIST SYSTEM CAMERA & HEAD-UP-DISPLAY INSTALLATION ON H3 SERIES

APPLICABLE FROM: Vehicles equipped with ABS-8
H3-41, H3-45 coaches from K-0185
H3-41 VIP, H3-45 VIP from K-0295

Revision: A Added on page 16: Proceed to the alignment of the radar sensor May 26, 2021
using Maintenance Information MI14-34.

1. KITS REQUIRED.....	2
2. MATERIAL.....	3
3. INSTALLATION PROCEDURE.....	5
4. PREVOST DRIVER ASSIST™ - INSTALLATION SUMMARY.....	31
5. ADDITION OF PARAMETERS FOR THE INTEGRATION OF PREVOST DRIVER ASSIST™ SYSTEM	32
6. WINDSHIELD CAMERA CALIBRATION	47
7. PARTS / WASTE DISPOSAL.....	57
8. APPENDIX A.....	58

PREVOST

1. KITS REQUIRED

All cases	order kit 0610440
-----------	-------------------

then



H3-41 & H3-45 coaches not previously equipped with ACB option	order supplemental kit 0610442
H3-41 VIP & H3-45 VIP not previously equipped with ACB (Active Cruise with Braking) option	order supplemental kit 0610441

then



H3-41 & H3-45 coaches from VIN K-0185 (incl) up to M-1109 (incl)	order supplemental kits 0610462 & 0611016
H3-41 VIP & H3-45 VIP from VIN K-0295 (incl) up to M-1109 (incl)	order supplemental kits 0610462 & 0611016
H3-41 VIP & H3-45 VIP from VIN M-1110 (incl)	order supplemental kit 0610462

PREVOST

2. MATERIAL

Kit #0610440 (WINDSHIELD CAMERA, HUD, FLR21 RADAR SENSOR) includes the following parts:

Part No.	Description	Qty
380362	KIT HUD CPA	1
380367	KIT HUD HOLDER CPA	1
564257	STAND-OFF ADJUSTER KIT, FLR20/21	1
880060	BRACKET, WINDSHIELD CAMERA	1
880061	RADAR SENSOR FLR21- COMPATIBLE WITH WINDSHIELD CAMERA	1
880062	WINDSHIELD CAMERA - SERVICE	1
3211135	CABLE COVER	1
3211136	CABLE COVER	1
5002198	SCREW, TAPPING PAN PH N500 4-20 X 5/16	6
IS-19037	INSTRUCTION SHEET	1
FI-19037	FEUILLE D'INSTRUCTION	1

Kit #0610442 (FLR 21 RADAR SUPPORT KIT - COACH) includes the following parts:

Part No.	Description	Qty
145223	STRIP, METAL	2
145225	SUPPORT, RADAR SENSOR	1
5001868	WASHER BELLEVILLE SS 8.4X18X2 (M8,5/16)	4
502780	SCREW, CAP HEX SS NSS M8X25	4

Kit #0610441 (FLR 21 RADAR SUPPORT KIT - VIP) includes the following parts:

Part No.	Description	Qty
145223	STRIP, METAL	2
145225	SUPPORT, RADAR SENSOR	1
145226	HARNESS PROTECTOR	1
5001648	SCREW, CAP HEXS SS NSS M6-1.0 X18MM LG	3
5001868	WASHER BELL SS 8.4X18X2 (M8,5/16)	4
500356	WASHER LOCK SERR N500 6.1X16X.9 (M6)	3
502780	SCREW, CAP HEX SS NSS M8X25	4

Kit #0610462 includes the following parts:

Part No.	Description	Qty
0610245	ACB GENERATION-2 HARNESS	1
563883	TOGGLE CAP, LANE DEPARTURE WARNING NGR53	1
562698	SWITCH, NGR EATON 8961K681 MO	1

Kit #0611016 includes the following parts:

Part No.	Description	Qty
0610405	HARNESS ACC LANE DEPARTURE WARNING SERVICE H3	1

Other parts that may be required:

Part No.	Description	Qty
504637	CABLE TIE, NYLON BLK (STD)	1
8631155	CABLE TIE 200X4.6 TREE MOUNT (30 POUNDS)	4
G37407	TEMPLATE USED TO CUT DASHBOARD COVER FOR HUD INSTALLATION	1
G37362	TEMPLATE, CAMERA POSITION MARKINGS if windshield doesn't already have position markings	1
G37363	WINDSHIELD CAMERA CALIBRATION TOOL	1
640048	CALIBRATION TARGET, WINDSHIELD CAMERA	1
MI14-34	RADAR SENSOR ALIGNMENT PROCEDURE	1
MI20-14	MAINTENANCE INFORMATION - PREVOST DRIVER ASSIST™ - WINDSHIELD REPLACEMENT EQUIPPED WITH CAMERA	1

Mandatory equipment:

Description	Qty
SERVICE CENTER LAPTOP COMPUTER with PTT & Bendix ESP	1
FORMATION LAPTOP COMPUTER with SPTAC & ACom only	1
VOCOM-1 USB COMMUNICATION INTERFACE	1

NOTE

Material can be obtained through regular channels.

3. INSTALLATION PROCEDURE



DANGER

Park vehicle safely, apply parking brake, stop the engine. Prior to working on the vehicle, set the ignition switch to the OFF position and trip the main circuit breakers equipped with a trip button. On Commuter type vehicles, set the battery master switch (master cut-out) to the OFF position.

Lock out & Tag out (LOTO) must be performed during set-up, maintenance or repair activities. Refer to your local procedure for detailed information regarding the control of hazardous energy.

3.1. HEAD-UP-DISPLAY INSTALLATION

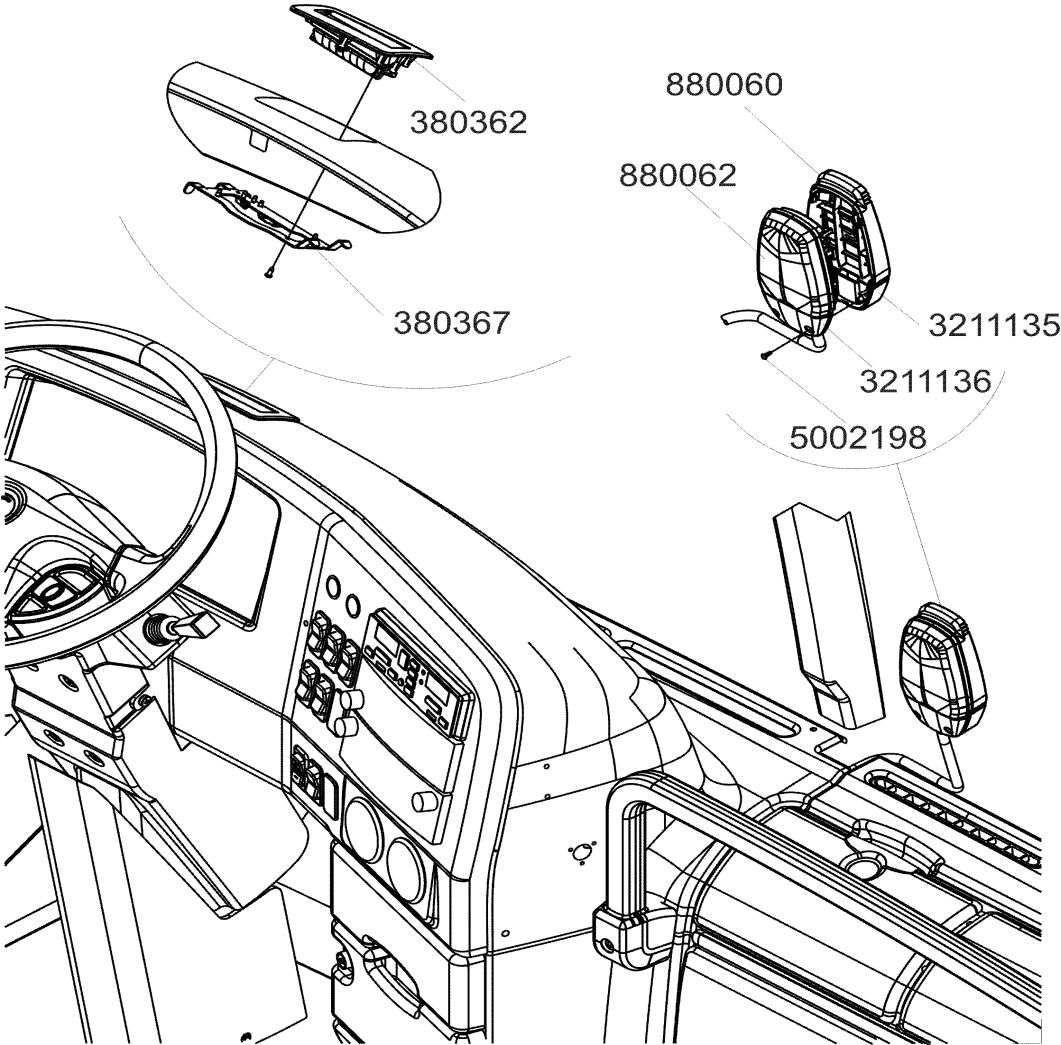

FIGURE 1: WINDSHIELD CAMERA (RIGHT) & HEAD-UP DISPLAY (LEFT)

1. Remove the dashboard cover and place on a workshop table.

- Place template G37407 on the dashboard, aligning the tab on the template with the tab found at the center of the dashboard cover.



G37407 TEMPLATE USED TO CUT DASHBOARD COVER FOR HUD INSTALLATION

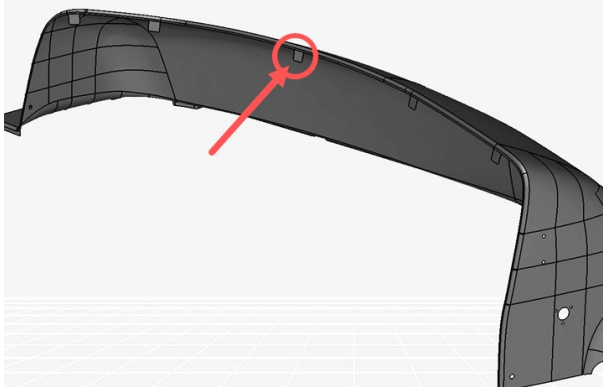

FIGURE 2



FIGURE 3

- Cut along the inner rectangle of the template to remove a piece of the dashboard cover. The result should look as shown on the image.

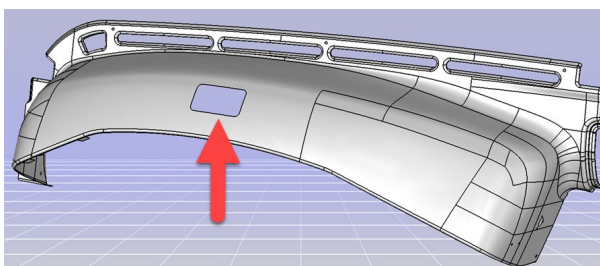

FIGURE 4

- Take a look at Figure 1.
- Install HUD module 380362 and secure with HUD holder 380367 and screws 5002198.

- MAKE SURE THE CONNECTOR IS ROUTED TOWARD THE WINDSHIELD AS SHOWN**
- DO NOT REINSTALL THE DASHBOARD COVER YET**

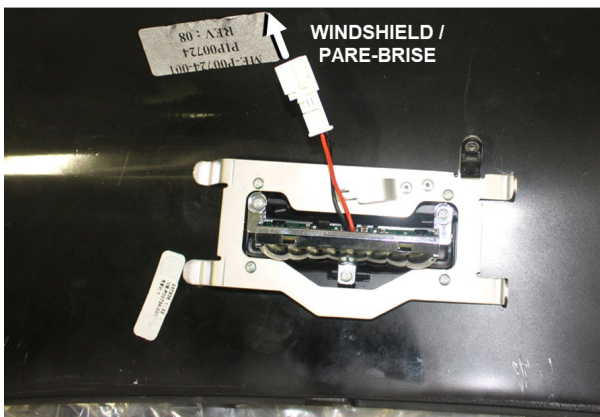
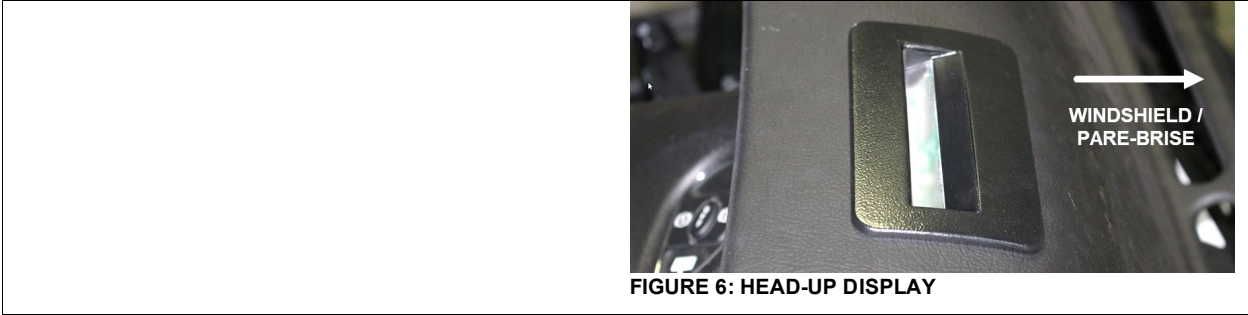

FIGURE 5



PREVOST

3.2. WINDSHIELD CAMERA INSTALLATION

6. Install the windshield camera bracket along with the camera. To do so, follow the procedure on **Maintenance Information MI20-14** found on Prevost technical Publications site.

<https://techpub.prevostcar.com/en/bulletins>

PREVOST

3.3. FLR21 RADAR SENSOR INSTALLATION

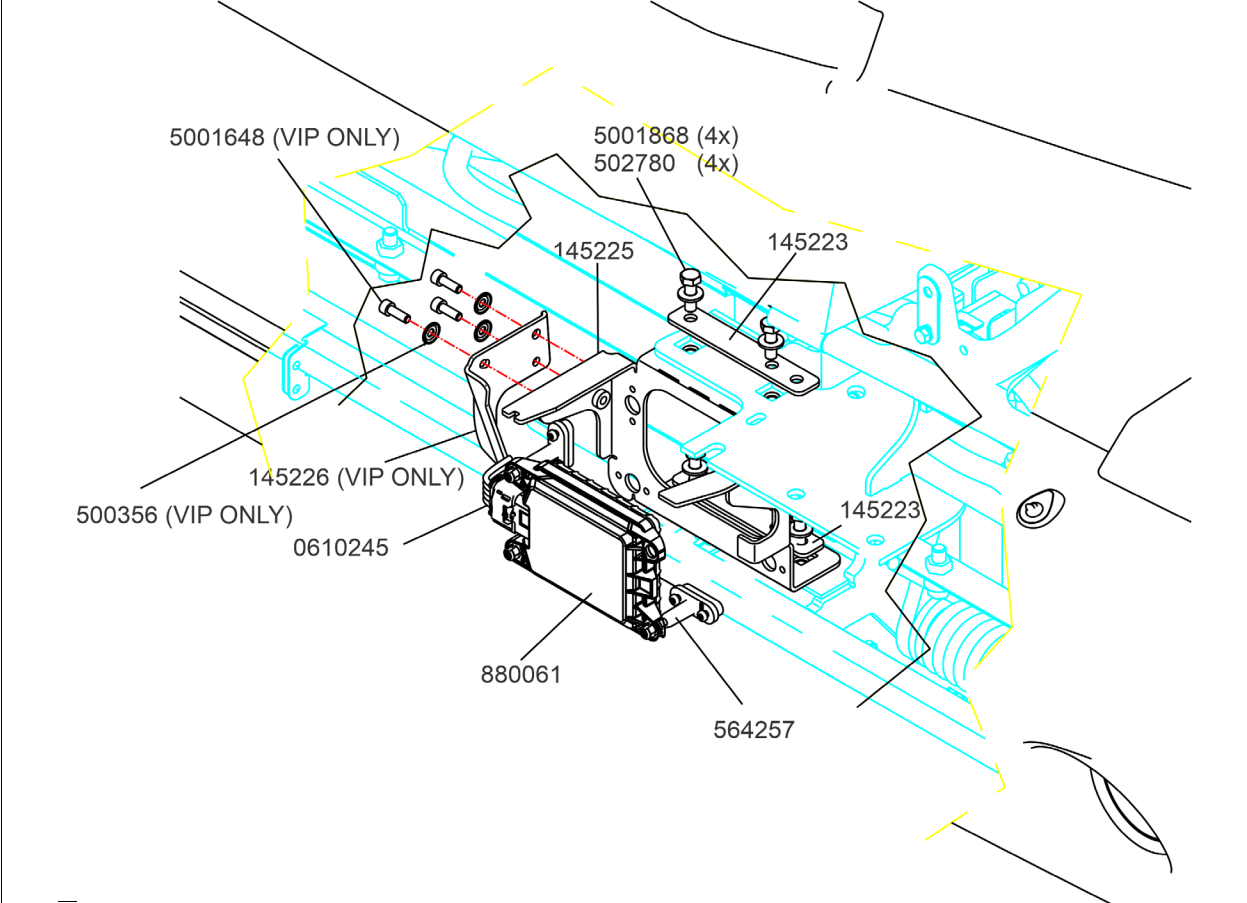
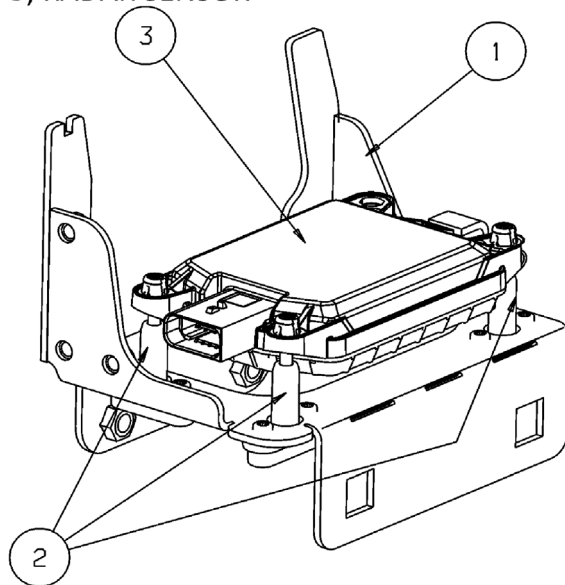

FIGURE 7: FLR21 RADAR INSTALLATION OVERVIEW

If already equipped with ACB system, the existing radar sensor must be replaced with radar sensor 880061 that is compatible with the windshield camera.

- 1) SUPPORT
- 2) STAND-OFF ADJUSTERS
- 3) RADAR SENSOR



STAND-OFF ADJUSTERS ARE NOT REUSABLE. DO NOT SEPARATE THE RADAR SENSOR FROM THE STAND-OFF ADJUSTERS IN ORDER TO REPLACE A DEFECTIVE RADAR SENSOR.

STAND-OFF ADJUSTOR ASSEMBLIES ARE PRE-ADJUSTED BEFORE DELIVERY IN ORDER TO RESPECT A PRECISE MEASUREMENT BETWEEN THE RADAR SENSOR AND THE SUPPORT, **DO NOT SCREW, UNSCREW OR ALTER THE INITIAL POSITION OF THE STAND-OFFS ADJUSTMENT SCREW.** DO NOT SEPARATE THE STAND-OFF CLIP FROM THE RADAR SENSOR RECEPTACLE. DOING SO WILL DAMAGE THE STAND-OFF CLIP.

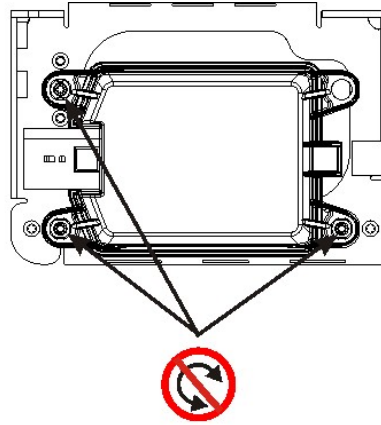

PRE-ADJUSTED STAND-OFF SCREWS

DO NOT SCREW, UNSCREW OR ALTER THE INITIAL POSITION OF THE STAND-OFFS ADJUSTMENT SCREW

IMPORTANT NOTES

BEFORE PROCEEDING TO THE REPLACEMENT, MAKE SURE THAT THE BUMPER IS PROPERLY POSITIONED, IF NOT THE RADAR SENSOR AND ACB SYSTEM MAY OPERATE IMPROPERLY.

IF THE BUMPER SUFFERS DAMAGES AFTER A SHOCK AND IS IMPROPERLY POSITIONED, A REPOSITIONING OR ADJUSTMENT OF THE BUMPER WILL BE NECESSARY PRIOR PROCEEDING TO THE ALIGNMENT OF THE RADAR SENSOR. RADAR SENSOR ALIGNMENT IS DONE IN RELATION TO THE BUMPER, IF THE BUMPER POSITION IS NOT ADEQUATE, THE RADAR AND ACB SYSTEM MAY OPERATE IMPROPERLY.

IF THE BUMPER POSITION ADJUSTMENT IS DONE, THEN THE RADAR SENSOR ALIGNMENT PROCEDURE MUST BE DONE. **IN THIS CASE, REFER TO MAINTENANCE INFORMATION MI14-34.**

Vehicle already equipped with ACB only

7. Unscrew 4 mounting screws and then remove the radar sensor mounting support and disconnect the radar sensor harness. **Keep existing hardware for reuse.** If needed, cut one or two nylon ties securing the harness to ease removal.

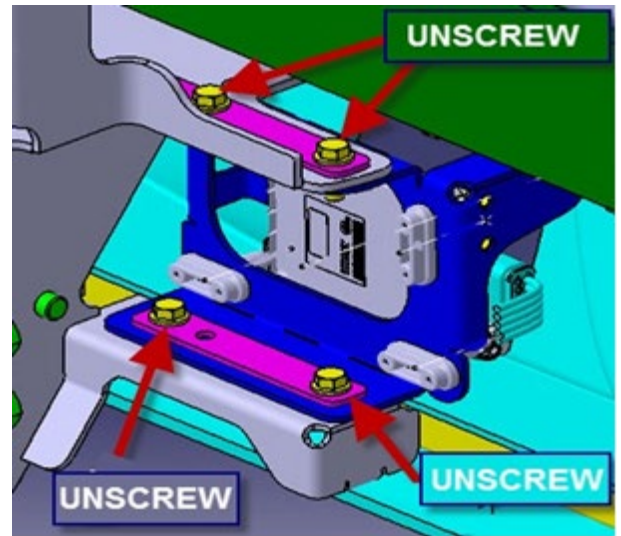

FIGURE 8

Vehicle already equipped with ACB only

8. Detach the existing radar sensor from its support.
9. Discard the existing radar sensor cable. It will not be reused because it is missing 1 circuit.

Vehicle already equipped with ACB only

10. Remove the existing stand-off adjusters from the support and discard the adjusters.

Vehicle not previously equipped with ACB only

11. Using the template (Figure 10), cut the bumper skin as shown on Figure 9.

NOTE: opening to be centered vertically on the surface.

Using an oscillating multi-tool gives good results.



NOTE: Print the template (Figure 10) on a sheet of paper. Set the printing size (%) so that the measurement center to center between the holes respects 137 mm when measuring with a ruler on the printing.

12. Drill two (2) holes of 7mm diameter.

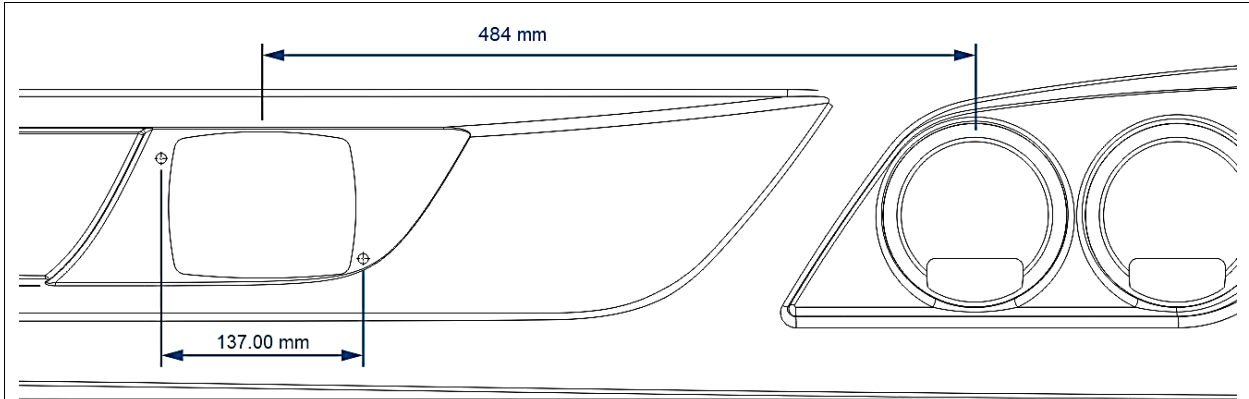

FIGURE 9: FRONT BUMPER

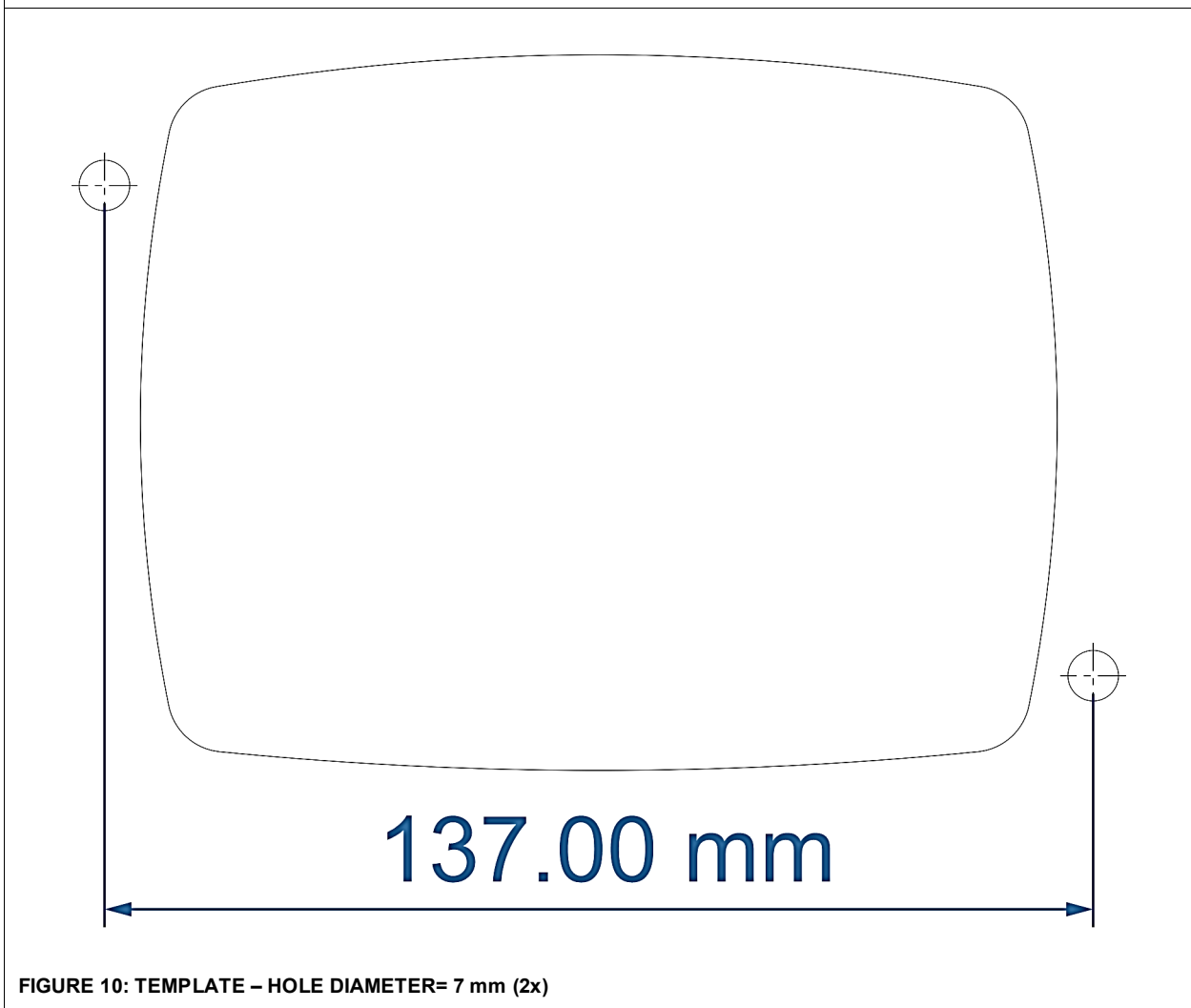

FIGURE 10: TEMPLATE – HOLE DIAMETER= 7 mm (2x)

13. Secure three (3) stand-off adjusters to the radar sensor mounting support 145225. Use the six (6) mounting screws included with the stand-off adjuster kit.

Prescribed torque: 25 lb-ft

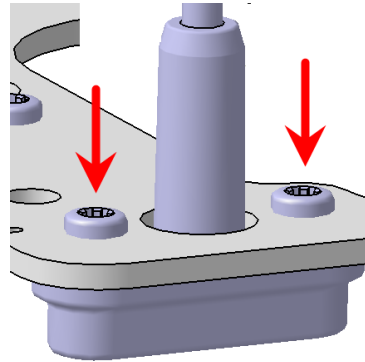

FIGURE 11

14. Engage the stand-off adjusters in the radar sensor assembly receptacles, placing the side that has no decal on top and the connector on L.H. side.



= no decal on this side

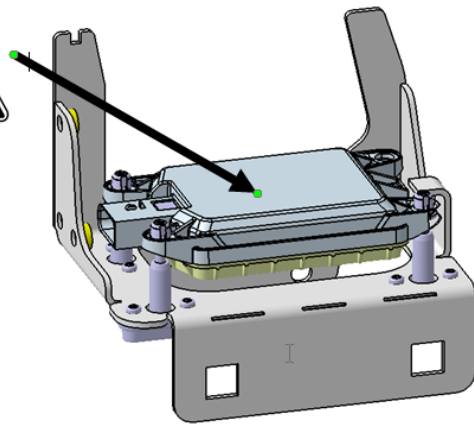

FIGURE 12

15. Stand-off adjusters height is pre-adjusted. However, validate dimension A at the three stand-off adjusters and adjust the height only if necessary.

A = 39.5 mm \pm 0.5 (1.55 in \pm 0.02)

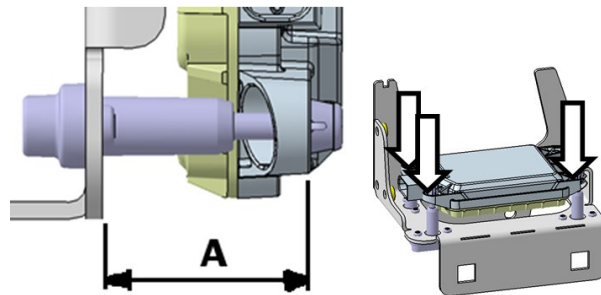

FIGURE 13

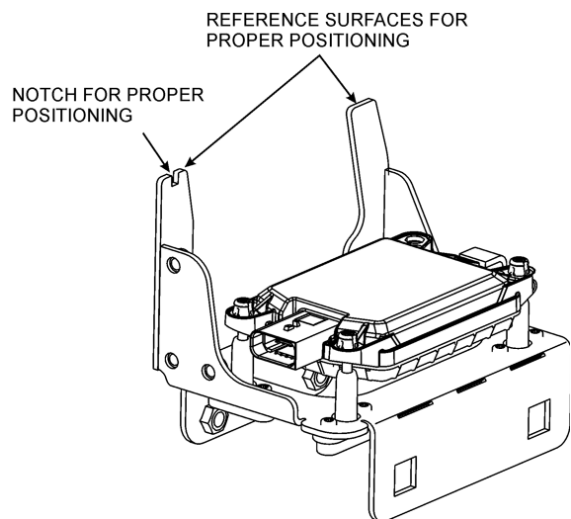

FIGURE 14

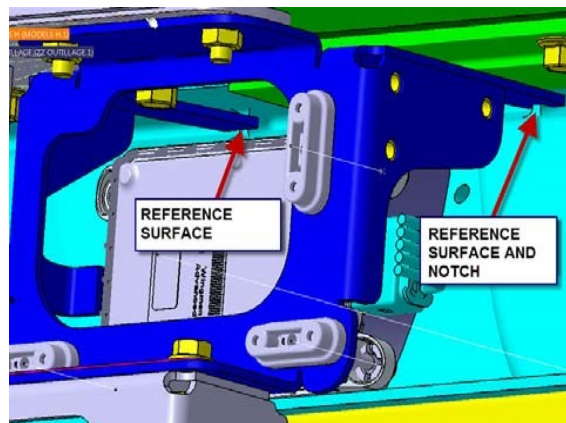

FIGURE 15

16. Radar sensor installed.

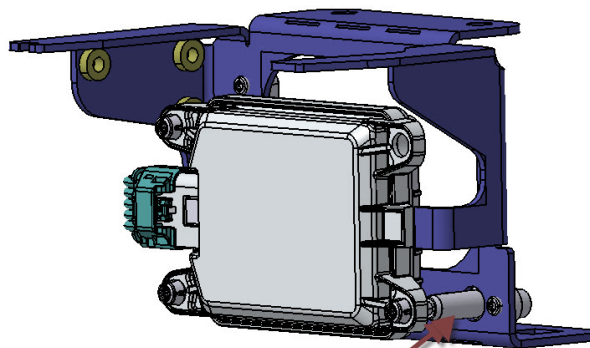

FIGURE 16

17. Reinstall the radar sensor complete with mounting support onto the bumper.

Use:

Cap screw 502780 qty: 4

Washer belleville 5001868 qty: 4

Metal strip 145223 qty: 2

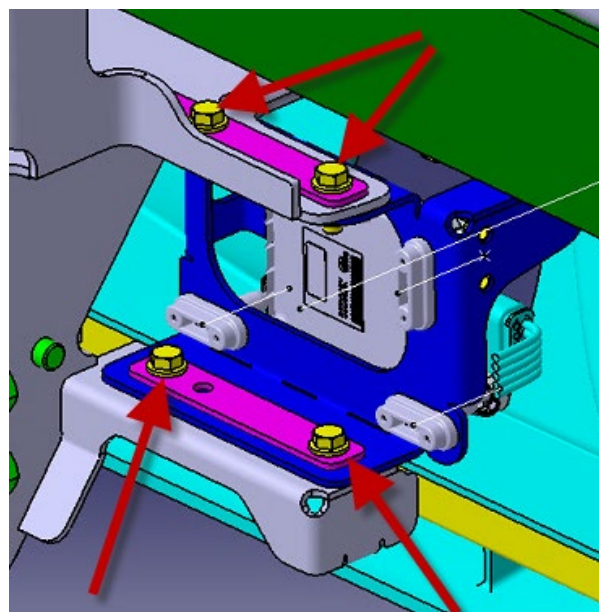

FIGURE 17

18. Plug connector A114A of cable 0610245 to the radar sensor.
19. Route cable as shown and secure with 1 nylon tie 50463 and 3 cable tie tree mounts 8631155.

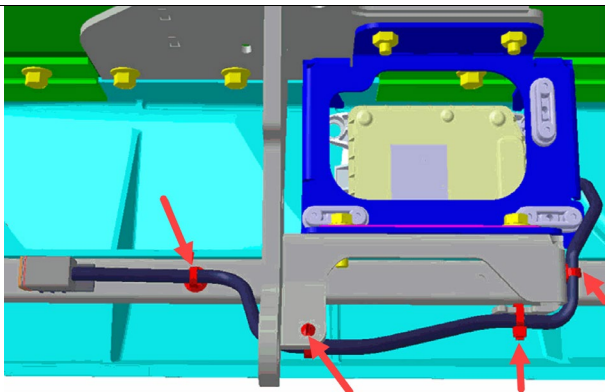

FIGURE 18

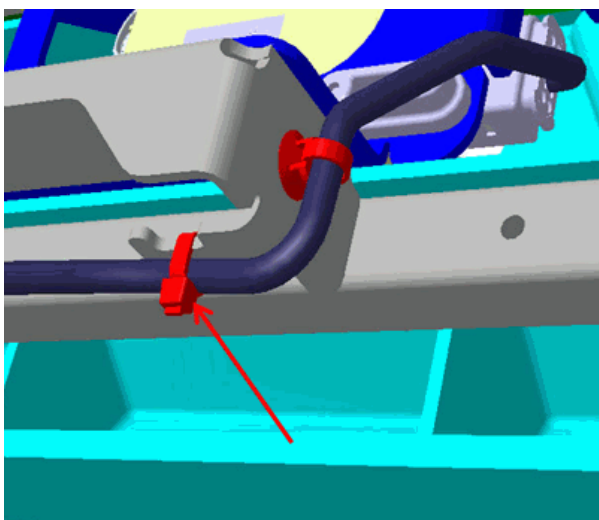

FIGURE 19

20. Proceed to the alignment of the radar sensor using Maintenance Information MI14-34.

3.4. ELECTRICAL HOOK-UPS

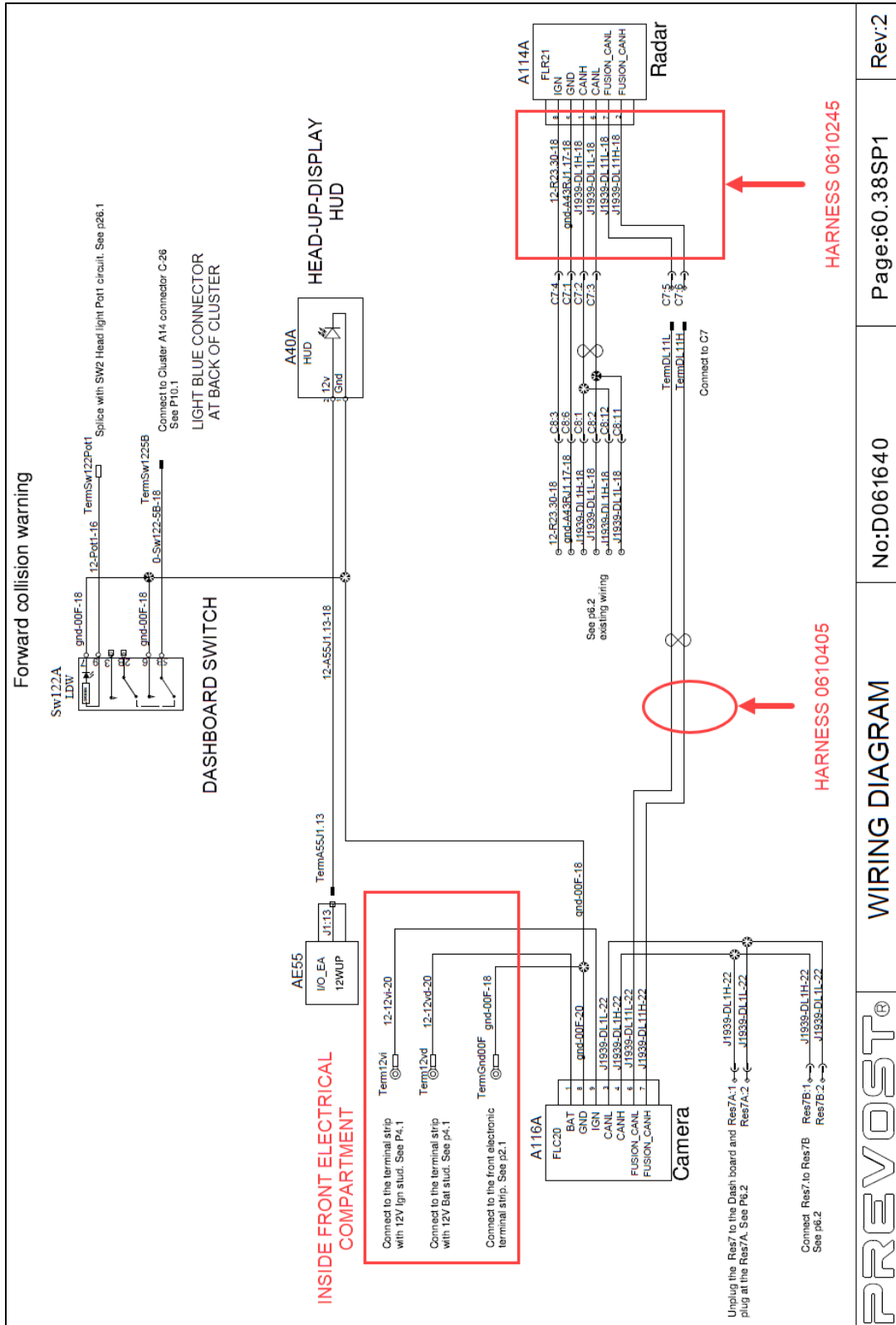

FIGURE 20: ELECTRICAL HOOK-UPS OVERVIEW 1

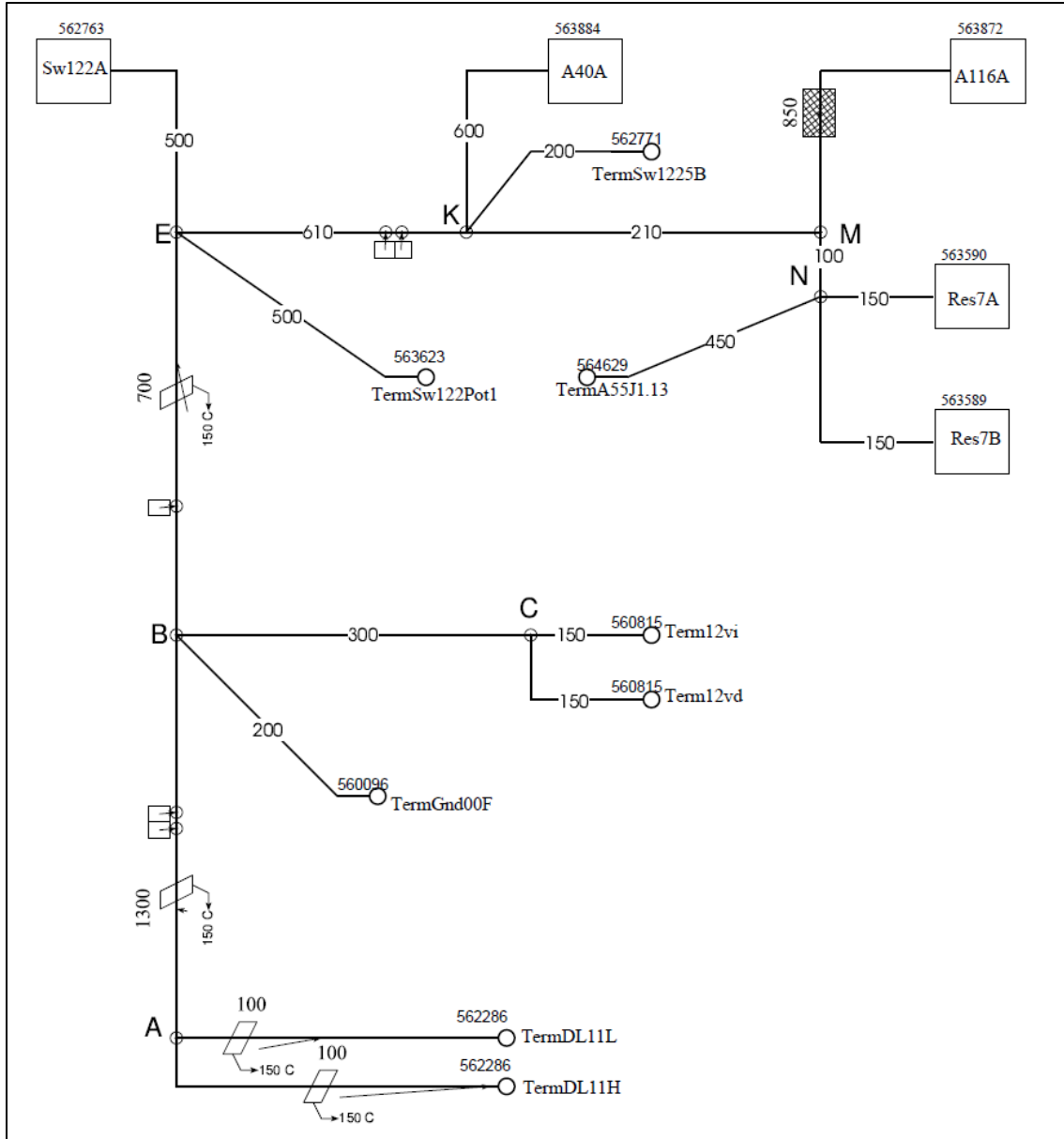

FIGURE 21: 0610405 HARNESS

PREVOST

RADAR SENSOR

21. Starting from behind the dashboard, route twisted circuits DL11L (green) & DL11H (yellow) of harness 0610405 up to the radar sensor vehicle-side harness C7 pin-housing connector.

22. Insert DL11L (green) & DL11H (yellow) pin terminals into C7 pin-housing connector as shown on the images.

DL11L (green) to C7 cavity 5

DL11H (yellow) to C7 cavity 6

See Appendix A Deutsch DT connector

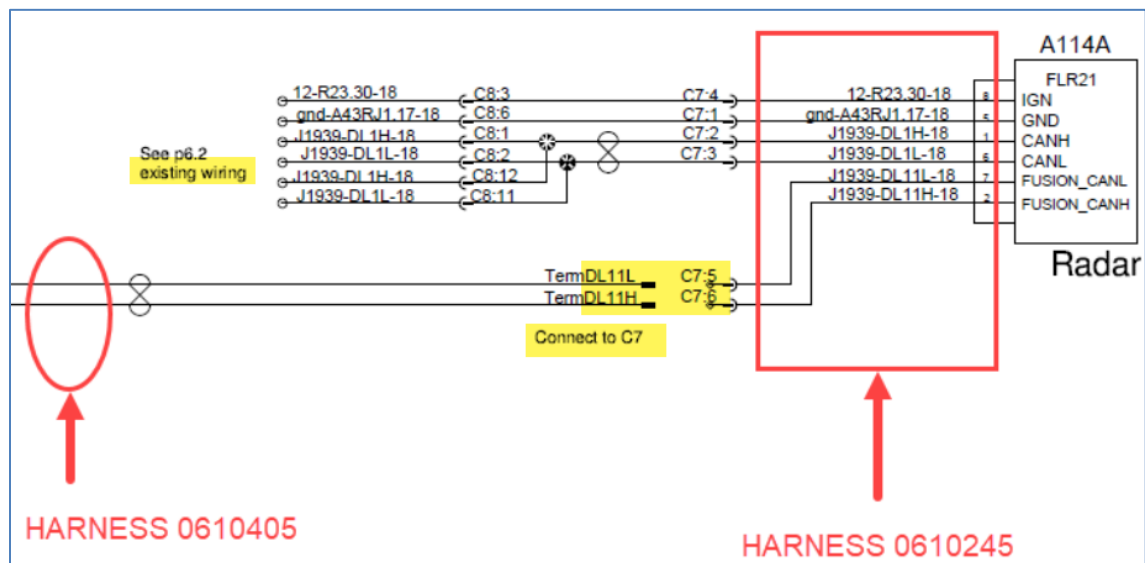

FIGURE 22

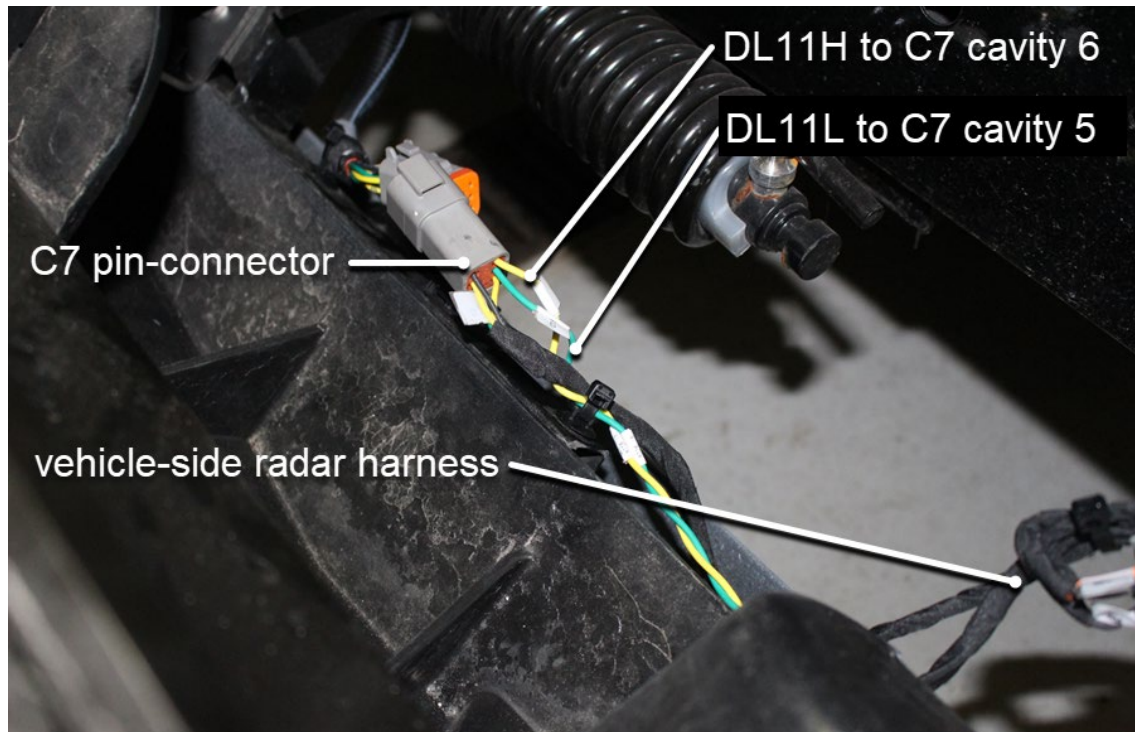

FIGURE 23: RADAR SENSOR HARNESS – NOTE THE INSTALLATION OF A CABLE TIE TREE MOUNTS 8631155

PREVOST

WINDSHIELD CAMERA

23. Connect the proper branch of harness 0610405 to the windshield camera.

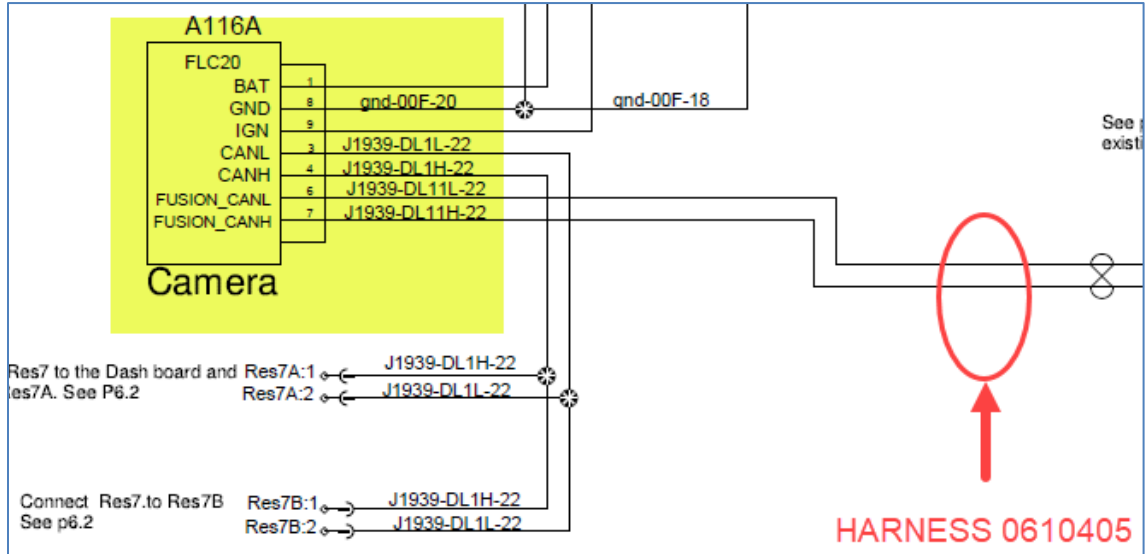

FIGURE 24

PREVOST

FRONT ELECTRICAL COMPARTMENT

24. Route harness 0610405 circuits 12-12VI, 12-12VD & GND-00F up to the front electrical compartment.
25. Connect 12-12VI to the 12V Ign terminal block.
26. Connect 12-12VD to the 12V Bat terminal block.
27. Connect GND-00F to the electronic ground stud.

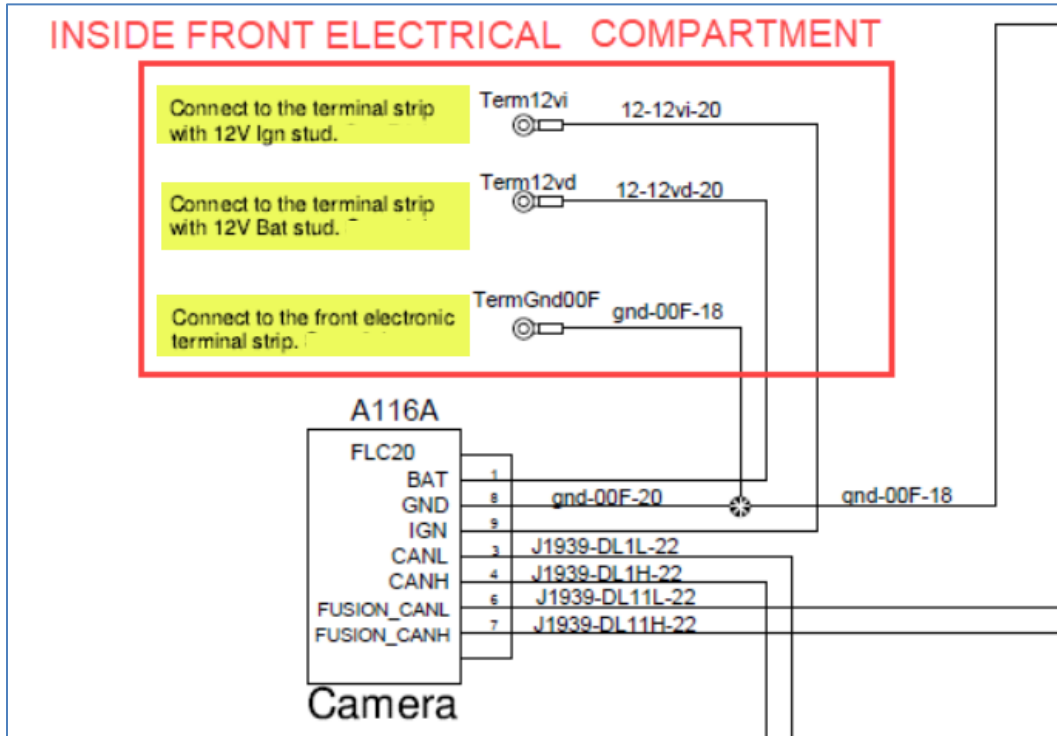

FIGURE 25

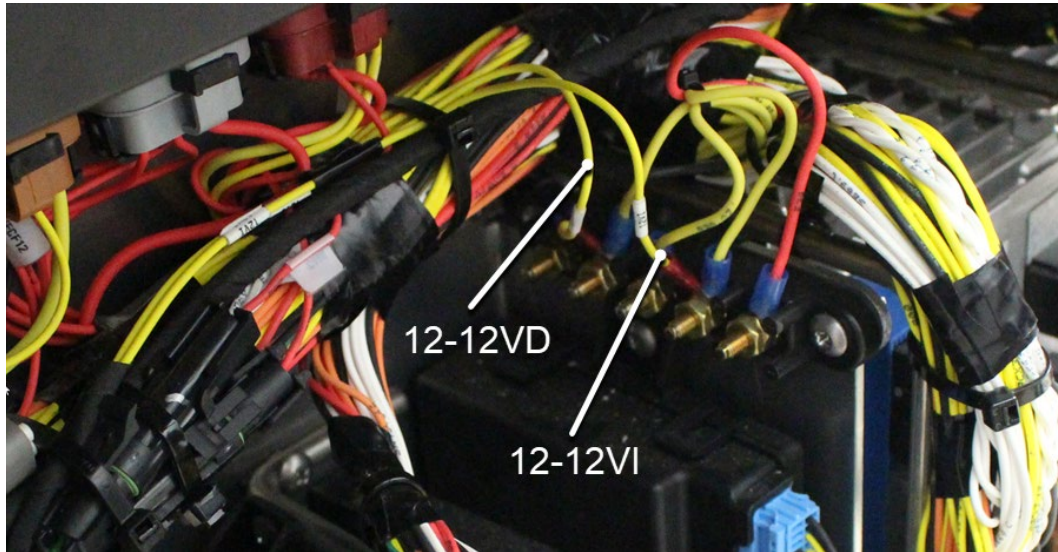

FIGURE 26: INSIDE THE FRONT ELECTRICAL COMPARTMENT - 12V IGN & 12V BAT TERMINAL BLOCK



FIGURE 27: ELECTRONIC GROUND STUD

PREVOST

DASHBOARD MULTIPLEX MODULE AE55

28. Connect circuit A55 J1.13 to connector J1 cavity 13 (brown connector) of Multiplex module AE55 located behind the dashboard.

See Appendix A Electronic Module connector

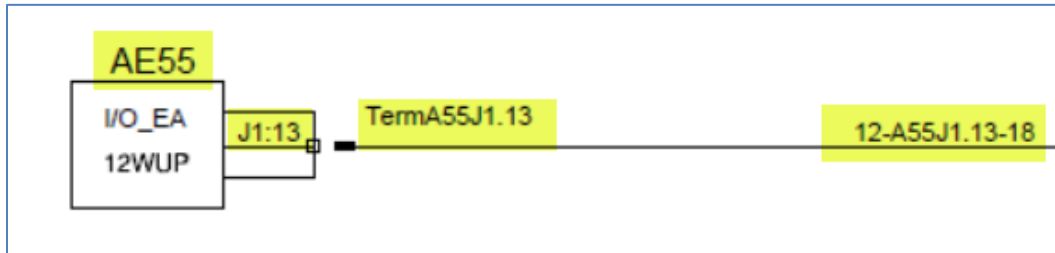

FIGURE 28

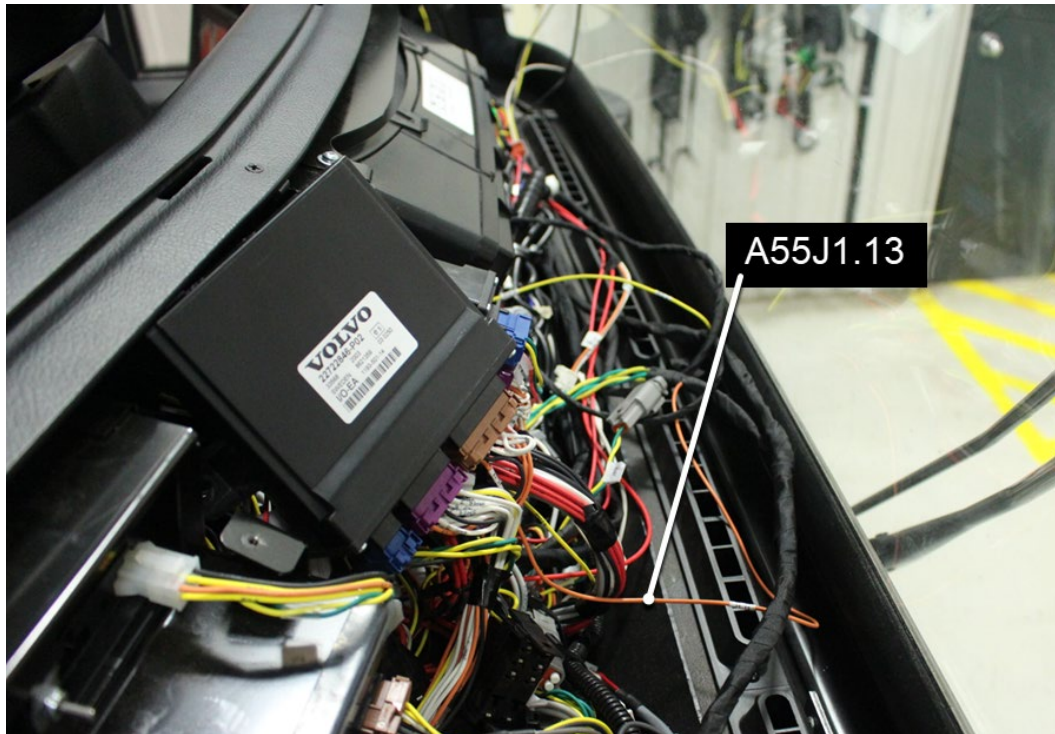

FIGURE 29

PREVOST

RESISTOR 7

29. Among the dashboard harnesses, locate resistor 7 (RES7).

30. Unplug RES7 from its connector.

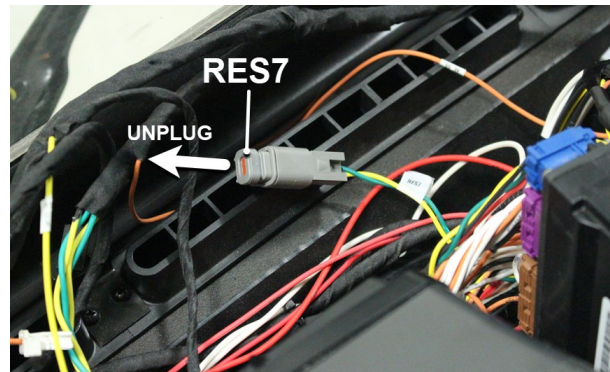

FIGURE 30

31. Plug RES7A connector of harness 0610405 to former RES7 connector.

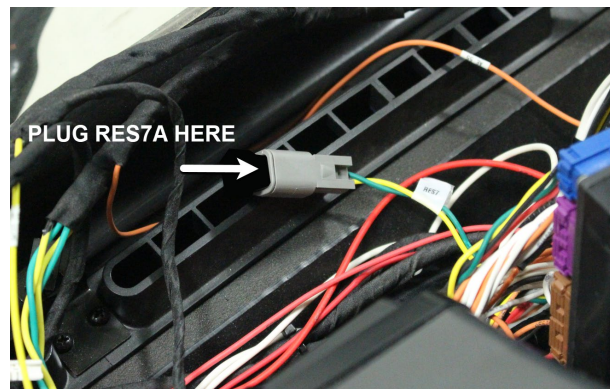

FIGURE 31

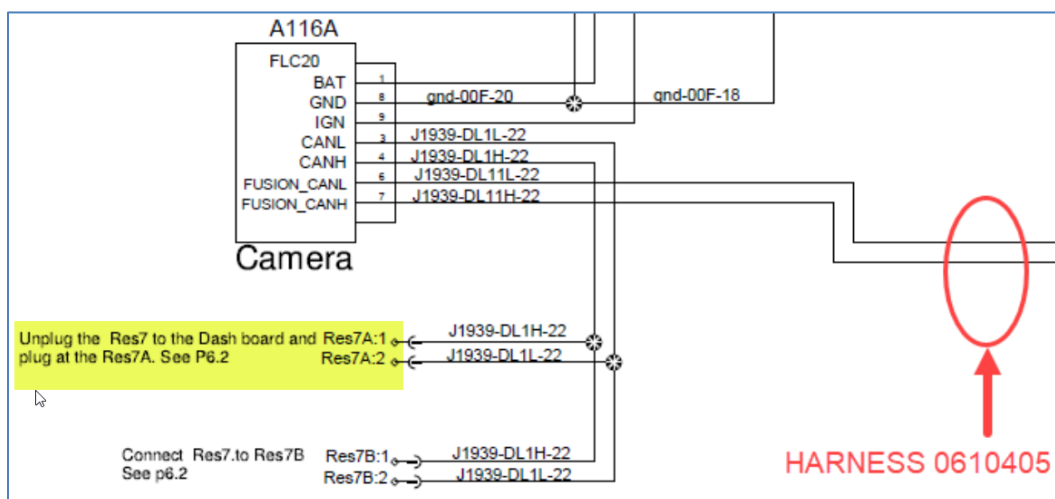

FIGURE 32

32. Plug RES7 to connector RES7B of harness 0610405.

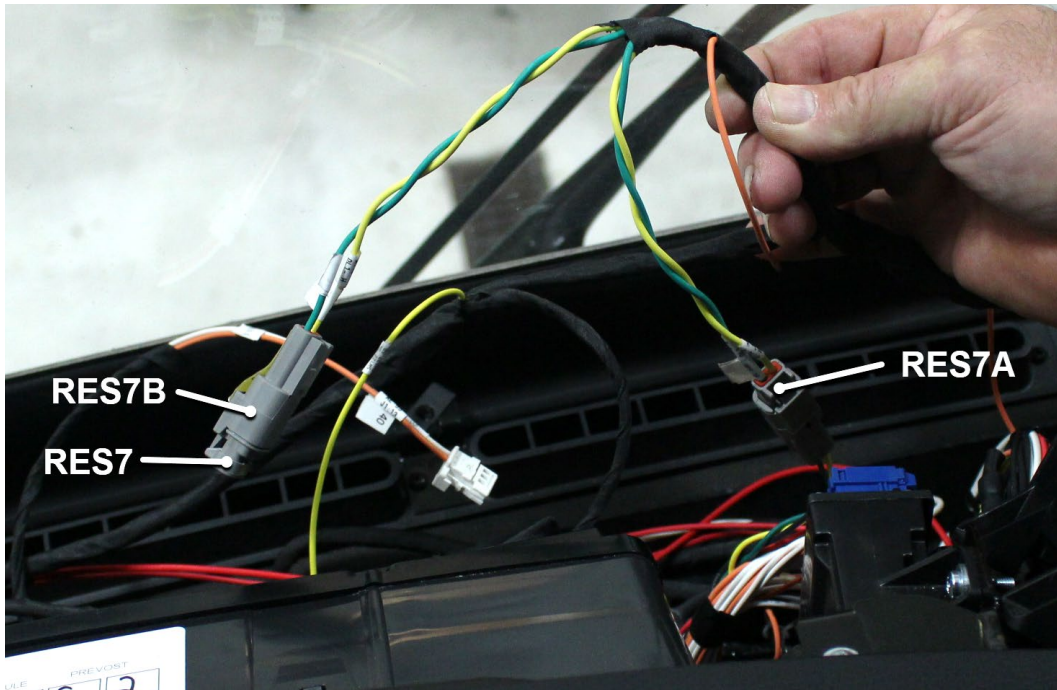

FIGURE 33

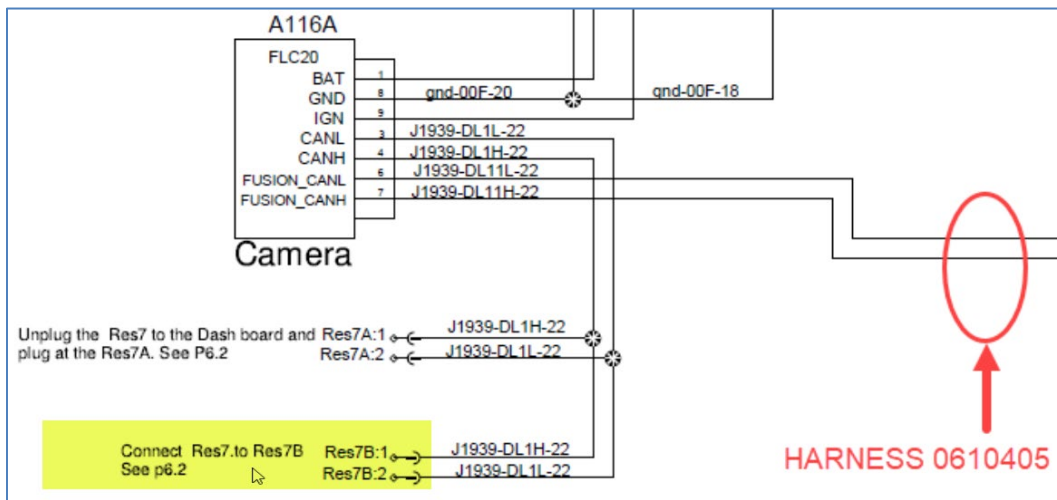
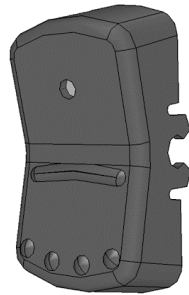

FIGURE 34

PREVOST

SWITCH SW122A



563883

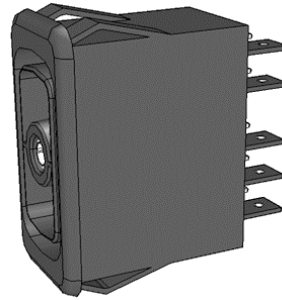

562698 SW122

33. Install switch SW122A onto the dashboard, located where shown on the image.



FIGURE 35

34. Connect SW122A to harness 0610406 as shown.

- Circuits GND-00F-18 to pin no. 6 & no. 7
- 12-POT1-16 to pin 9
- 0-SW122-5B-18 to pin 5B

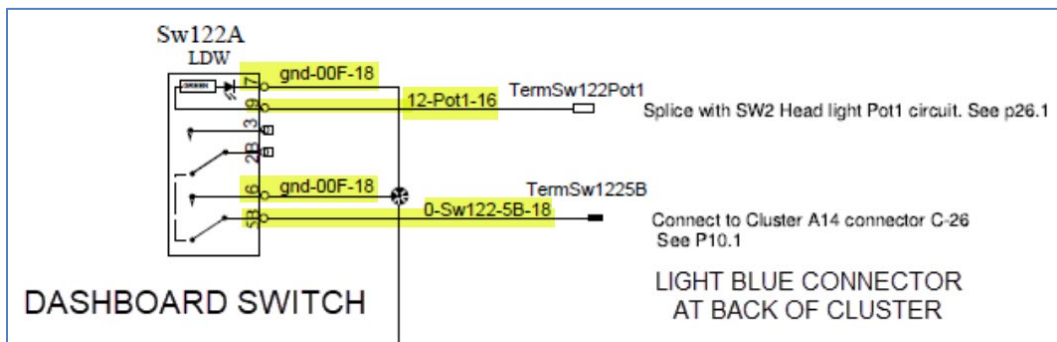

FIGURE 36

35. To provide illumination to switch SW122A, hook it up to another switch's lighting circuit controlled by the potentiometer rotary switch on the dashboard. Splice circuit 12-POT1-16 of harness 0610405 to circuit 12-POT1-18 of the headlights switch SW2.

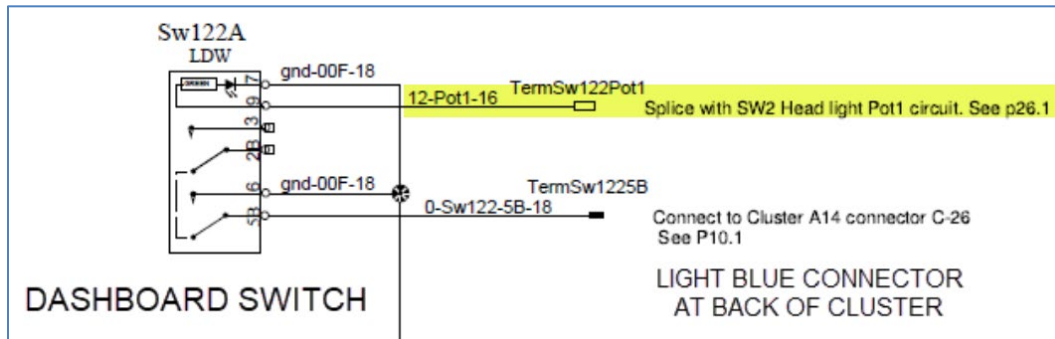

FIGURE 37

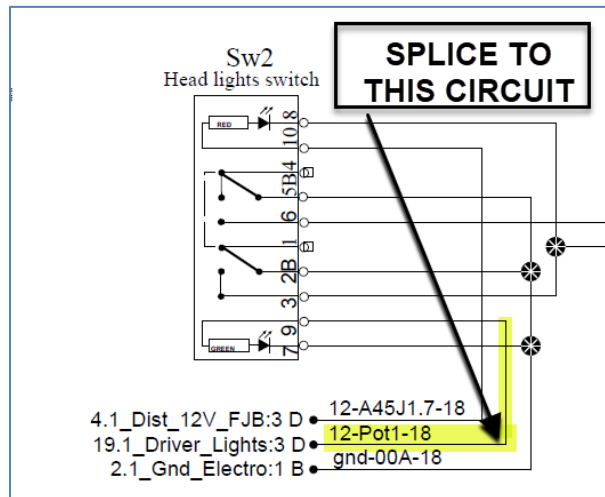

FIGURE 38: SWITCH SW2 HEADLIGHTS

36. Connect circuit 0-SW122-5B-18 of harness 0610405 to the cluster connector C pin 26 (blue connector behind the cluster).

See Appendix A JAE connector

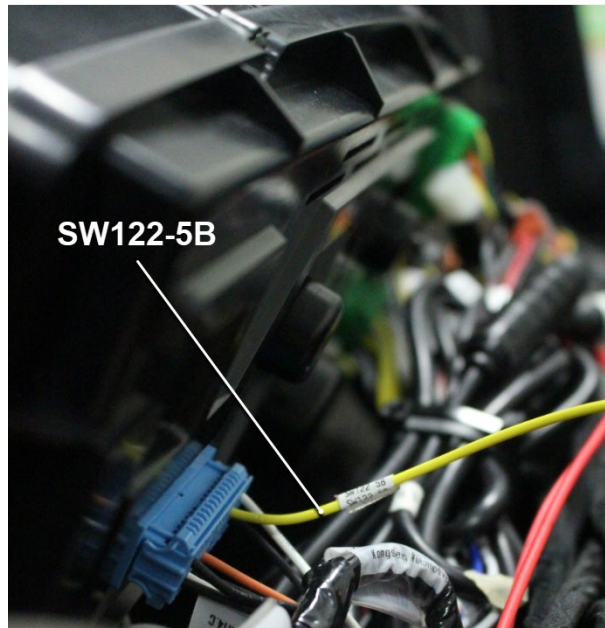

FIGURE 39

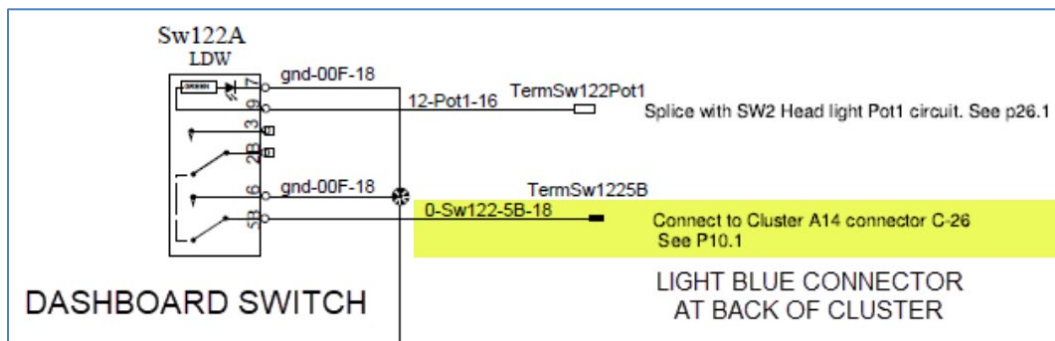

FIGURE 40

37. Install the toggle cap 563883.

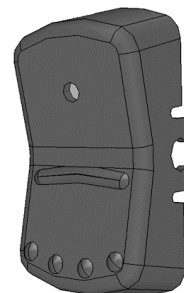

FIGURE 41

PREVOST

HEAD-UP-DISPLAY HUD

38. Connect circuit A55J1.13 & GND-00F-18 of harness 0610405 to the HUD module connector and reinstall the dashboard cover.



FIGURE 42: A55J1.13 & GND-00F-18

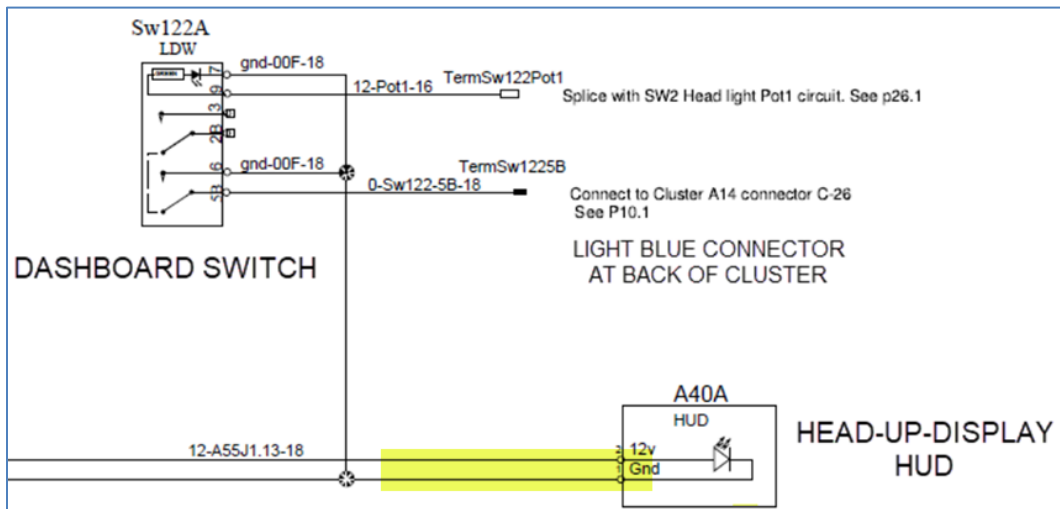

FIGURE 43

PREVOST

4. PREVOST DRIVER ASSIST™ - INSTALLATION SUMMARY



PREVOST

5. ADDITION OF PARAMETERS FOR THE INTEGRATION OF PREVOST DRIVER ASSIST™ SYSTEM

5.1. WITH SERVICE LAPTOP - Addition of parameters for the instrument cluster – running ACCESSORY KIT

1. Launch Premium TechTool software tool. In PROGRAM tab, select operation: 1700-22-03-06 Accessory Kit, then click START.

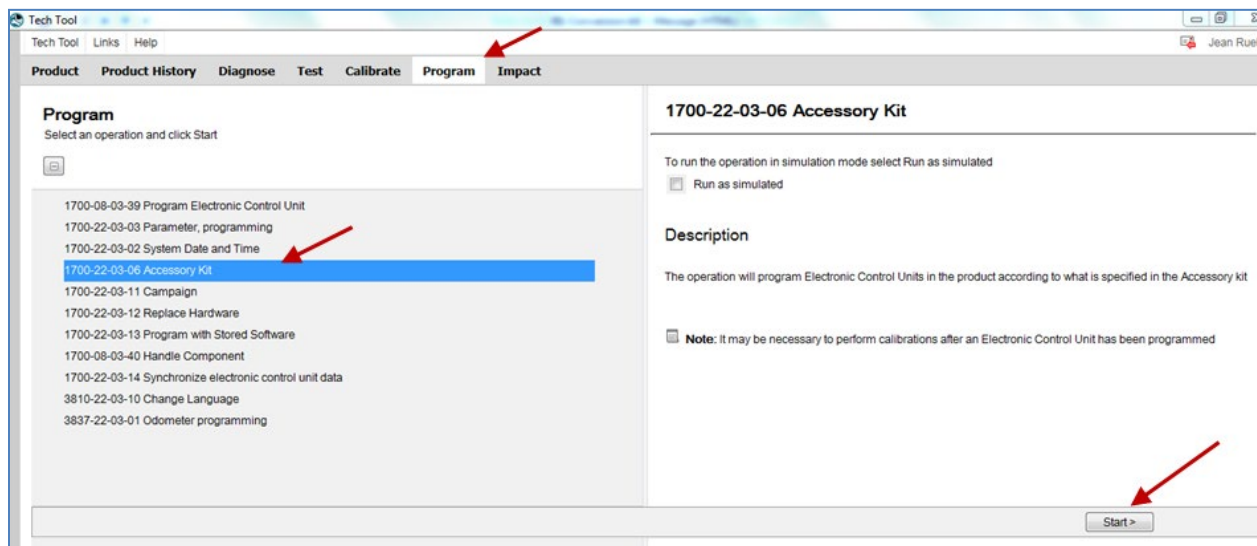
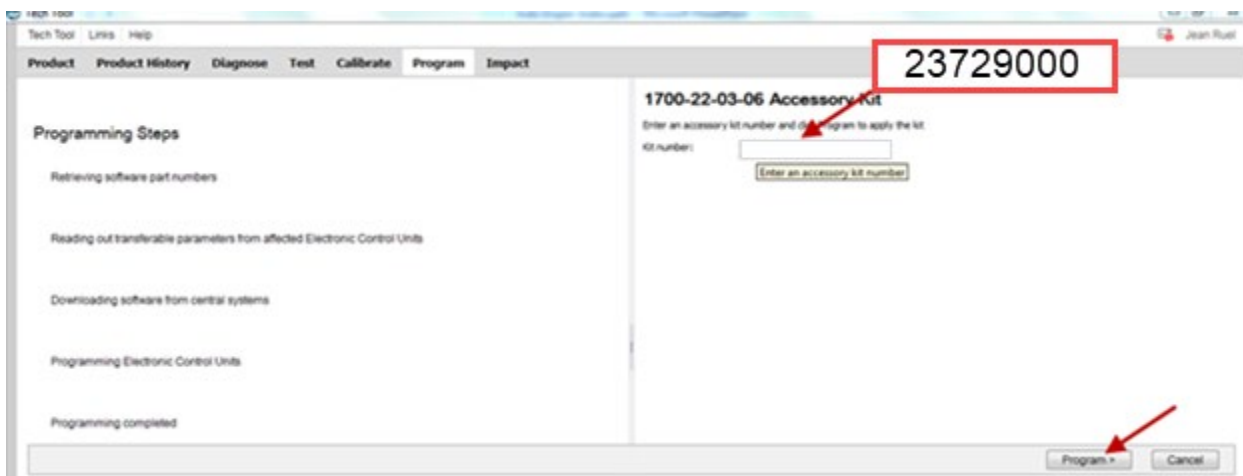

FIGURE 44

2. **Vehicles not previously equipped with ACB only:** Enter the accessory kit number **23729000**.
3. **Vehicles not previously equipped with ACB only:** Click on PROGRAM button below and then follow the instructions. The programming process will start.



4. **All vehicles:** Enter the accessory kit number **24035821**.

5. Click on PROGRAM button below and then follow the instructions. The programming process will start.

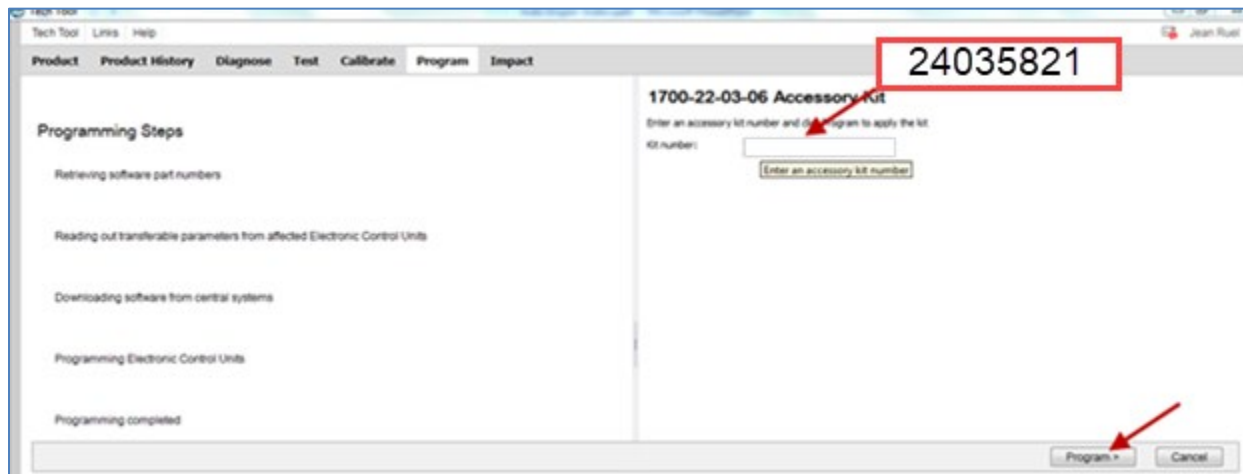

FIGURE 45

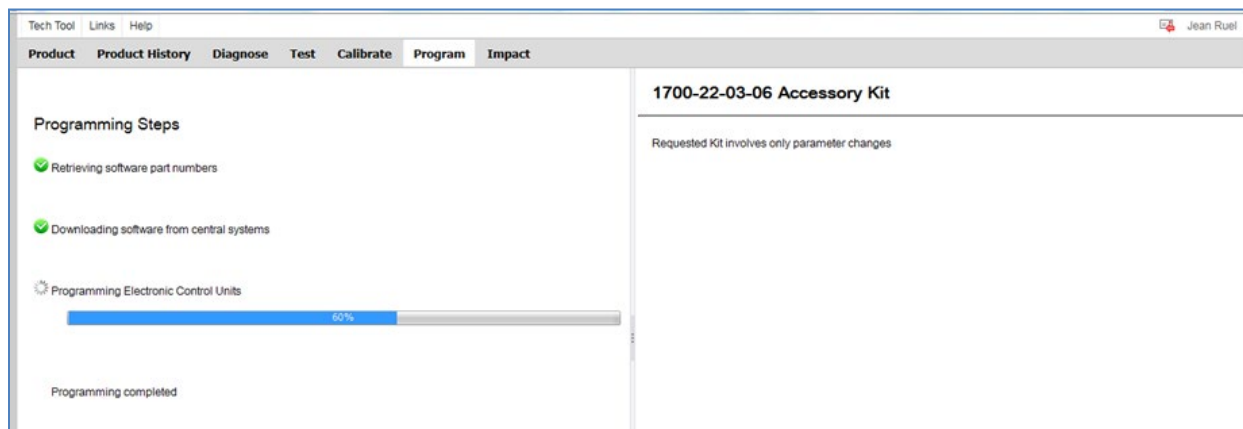

FIGURE 46

6. Program MID140 to the latest software version.

PREVOST

Vehicles not previously equipped with ACB only

5.2. WITH SERVICE LAPTOP - Addition of parameter ACB in Multiplex program for integration of ACB system

1. Connect VPG (Vehicle Program Generator) on the multiplex DB9 port.
2. Open VPG, enter vehicle ID, click SEARCH and select VEHICLE PARAMETERS tab.
3. Find parameter ACBCWS.
4. Select NEW VALUE and change value to YES in the drop-down list then click on SELECT.

Para	Description	S	Default Value	Previous Value	Current Value	New Value
ACBCWS	ACB		No	No	No	No
ALTTYP	Alternator type		Bosch	DelcoRemy	DelcoRemy	DelcoRemy
AXLMON	Front Axle Monitor		No	No	No	No
BATCNT	Battery Cycle Charge Count (0 to 20)		0	0	0	0
BKRLSW	Park Brake Release Switch		No	No	No	No
BRKTYP	Engine Brk or Retarder		Jacob	Jacob	Jacob	Jacob
BUPMON	Backup Monitor		Yes	Yes	Yes	Yes
CCCANC	CC Cancel with Wiper		No	No	No	No
CORDO	RH Cornering ON when door open (No	No	No	No
CORNLP	Cornering Lamp		No	No	No	No
CRKDIS	Crank Disable		No	No	No	No
CTRIGA	Coolant Temperature Regulation Pr		1	1	1	1
CTRPGA	Coolant Temperature Regulation Pr		17	17	17	17
CURBFL	Curbs Lights ON With RH Flasher		No	No	No	No
DAYTIM	Daytime Running Light		Yes	Yes	Yes	Yes
DECELL	Deceleration Feature on Engine Bra		Yes	Yes	Yes	Yes
DEFOST	Upper Defroster		No	No	No	No
DOCFLS	Rear docking with flasher		No	No	No	No

User: Jean Ruel (Service Rep.) Profile: Service Network: On-Line MID : Disconnected Last Update: 2021/03/12 14:26:14

5. Select the PROGRAM GENERATION tab and follow instructions according to the usual procedure.
6. Select the TRANSFER TO THE VEHICLE tab and follow instructions according to the usual procedure.

PREVOST

5.3. WITH SERVICE LAPTOP - Addition of parameters with BENDIX ESP software for integration of Prevost Driver Assist™ system

1. The computer must be connected (WIFI) to Volvo network.
2. Connect VOCOM-1 USB communication interface cable to the dashboard DDR (diagnostic data reader) connector.
3. Launch ESP software.



4. Enter the vehicle short VIN format (ex.: L-1092). Click SEARCH to access the vehicle General info tab.

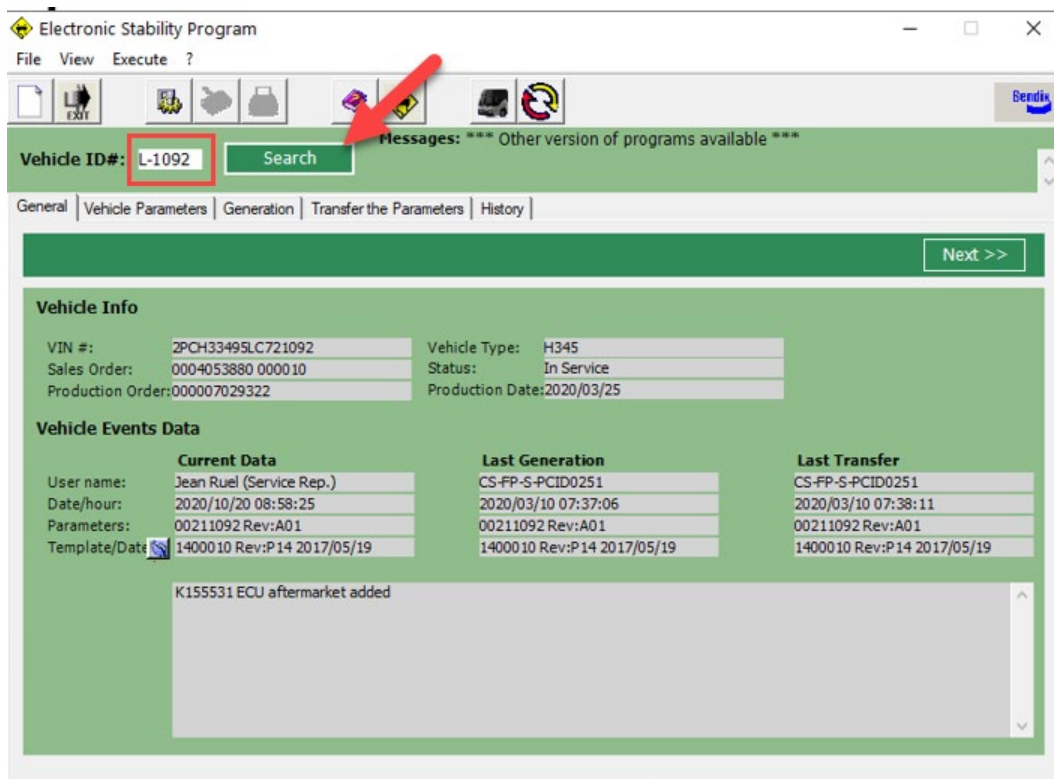

FIGURE 47

5. Select the icon shown on the image below to view available program version.

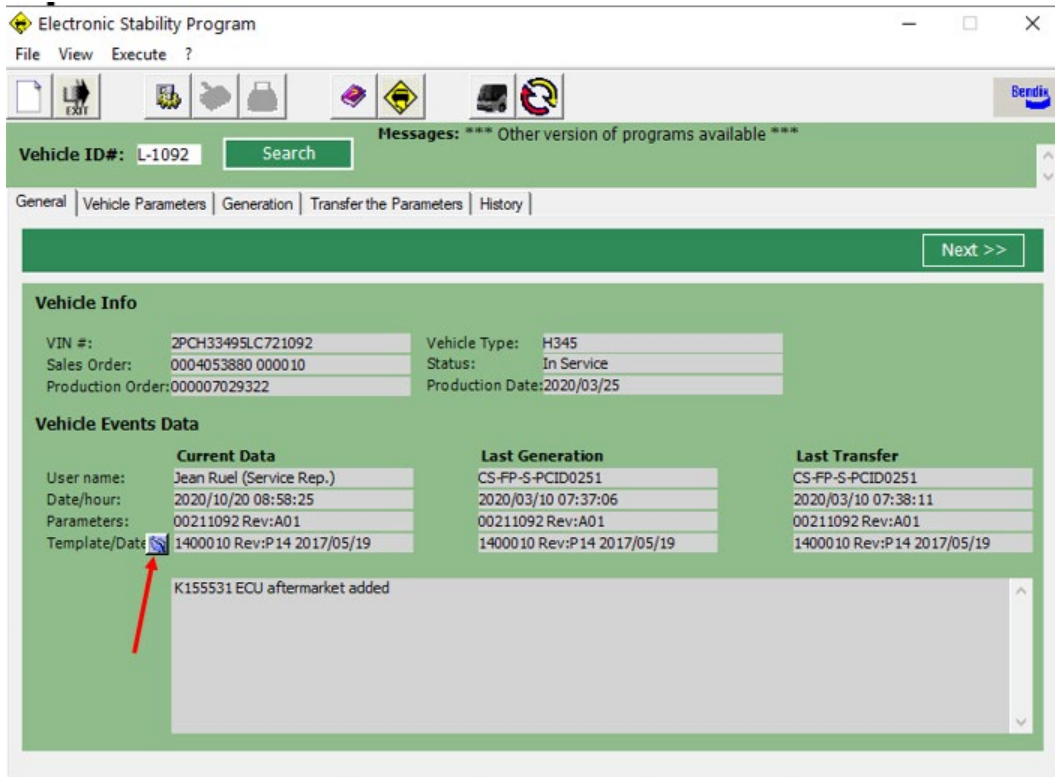

FIGURE 48

6. Program version must be updated from 1400010 to 1400011. Select 1400011 and then confirm by clicking on **YES**.

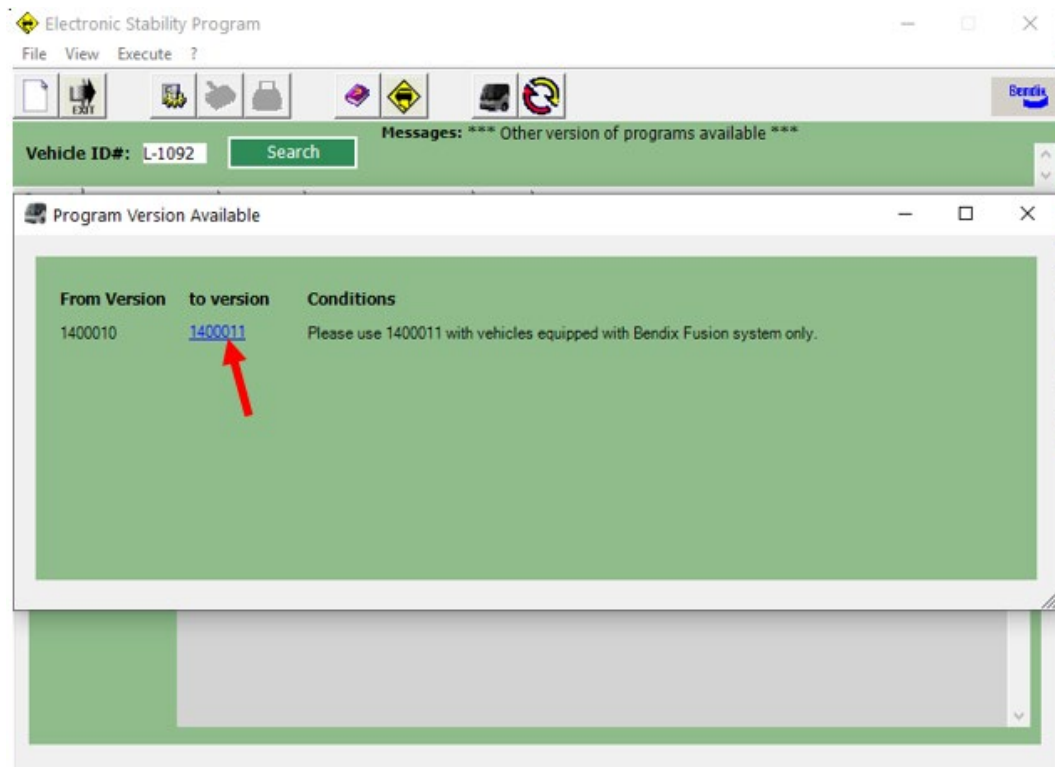

FIGURE 49

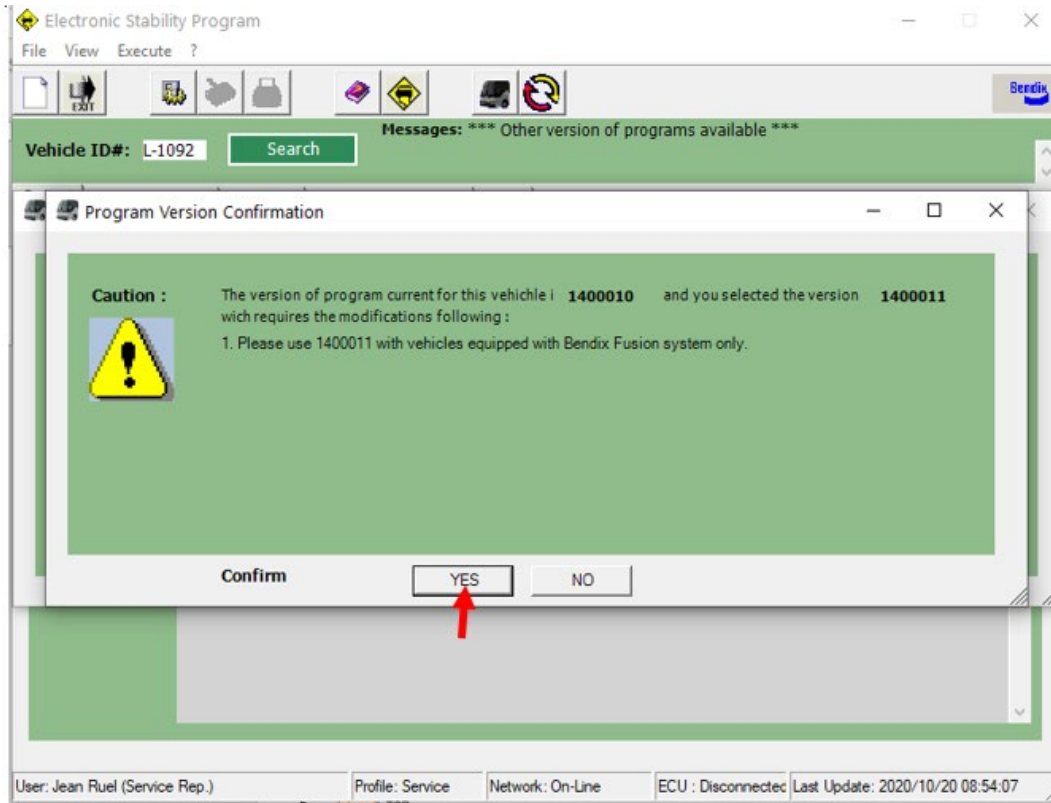

FIGURE 50

7. Return to **General tab** and check that the program current version is 1400011.

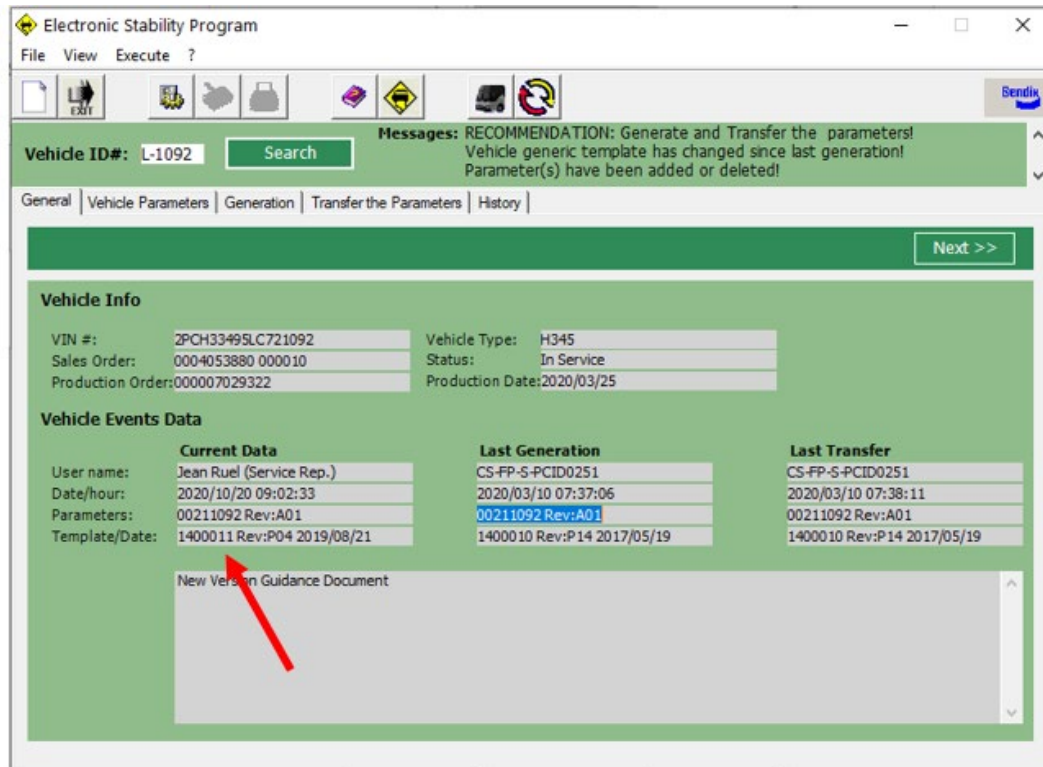

FIGURE 51

8. Select **Vehicle Parameters** tab.

9. Change the following parameters new value. Refer to the following table.

No	Parameter ID	Description	Change reason	H3-45 Parameter new value
1	ACBEN1	Enable ACB	add radar	1
2	ACFG22	ACB CONFIG 2	refresh	251
3	ACFG33	ACB CONFIG 3	refresh	191
4	AEBB82	conf ACC AEB	new	1
5	AEBSB4	AEBS AVAILABLE	new	1
6	ATCPAR	ATC Parameter	new	0
7	AUTCFG	EEP_FIXED.ACFG_CONF.B_ST.CONF_	new	0
8	AXDRT1	Axel drive tire 1	refresh	Select value to match DRIVE tire type
9	AXDRT2	Axel drive tire 2	refresh	Select value to match DRIVE tire type
10	AXDRT3	Axel drive tire 3	new	Select value to match DRIVE tire type
11	AXSTT1	Axel steer tire 1	refresh	Select value to match FRONT tire type
12	AXSTT2	Axel steer tire 2	refresh	Select value to match FRONT tire type
13	AXSTT3	Axel steer tire 3	new	Select value to match FRONT tire type
14	AXTGT1	Axel tag tire 1	refresh	Select value to match TAG tire type
15	AXTGT2	Axel tag tire 2	refresh	Select value to match TAG tire type
16	AXTGT3	Axel tag tire 3	new	Select value to match TAG tire type
17	CALSTA	CALSTATUS	new	Parameter value will be implemented automatically at calibration step (170)
18	CAMHGH	CAMERAHEIGHT	new	Parameter value will be implemented automatically at calibration step (192)
19	CO4B22	ACB parameter	add radar	1
20	COIDXX	ACB CONFIG INDEX	add radar	8
21	CONECU	EEP_FIXED.CONF_ECU_TYPE	new	2
22	DKMBR2	DEF_K_M_BRAKE_RA2	refresh	-5500
23	DXKINE	XBR K_I NEG	add radar	0.4
24	DXKPAD	XBR K_P ADD	add radar	0.4
25	DXKPNE	XBR K_P NEG	add radar	0.4
26	ETC7EN	EEP_FIXED.CAN_CONF_ETC7_VP15.B	new	0
27	FLC1B8	Msg PROP BDR	new	1

28	FLC2B8	CAMERA RECORDING FUSION EVENT	new	1
29	FLCANG	FLC IMAGERRAKEANGLE	new	2
30	FLCEDR	FLC ACTIVATEEDR	new	3
31	FLCLHW	FLC LEFTWHEEL	new	136
32	FLCOEX	CONF FLC FOEX	new	0
33	FLCOEY	CONF FLC FOEY	new	Parameter value will be implemented automatically at calibration step (60)
34	FLCRFX	FLC REFPOINTX	new	18
35	FLCRFY	FLC REFPOINTY	new	-13
36	FLCRHW	FLC RIGHTWHEEL	new	110
37	FSSLSC	EEP_FIXED.FS_SLS_CONF.B_ST.FS_	new	1
38	GRABSH	GRABBINGSHIFT	new	Parameter value will be implemented automatically at calibration step (27)
39	GRAPS_	DEF_P_SENSOR_GRADIENT	refresh	12920
40	HSAM2S	EEP_FIXED.CONF_BENDIX_HSA_OPTI	new	1
41	KAUF11	Press grad build steer	refresh	0.02646
42	KAUF22	Press grad build DRIVE	refresh	0.02744
43	KAUF33	Press grad build Tag	refresh	0.01666
44	KBAB11	Press grad exaust steer	refresh	0.02548
45	KBAB22	Press grad exaust DRIVE	refresh	0.02352
46	KBAB33	Press grad exaust TAG	refresh	0.0196
47	KOF3B2	KONF3EE.BIT2	refresh	2
48	LATOFF	ACB LATERAL OFFSET	add radar	0.419
49	MAXPS_	DEF_MAX_P_SENSOR	refresh	245.504
50	MINPS_	DEF_MIN_P_SENSOR	refresh	15.36
51	OFFPS_	DEF_P_SENSOR_OFFSET	refresh	1292
52	PCAAVG	EEP_FIXED.CONF_PC_T_INFL_AA_V	new	3
53	PCDAVG	EEP_FIXED.CONF_PC_T_INFL_DA_V	new	3
54	PCSAVG	EEP_FIXED.CONF_PC_T_INFL_SA_V	new	2
55	RA2AVA	EEP_FIXED.RA2_AVAILABLE	new	1
56	RA2DRI	EEP_FIXED.RA2_DRIVEN	new	0
57	ROANGL	ROLLANGLE	new	Parameter value will be implemented automatically at calibration step (0.005)
58	TCMNEE	ACB parameter	add radar	30
59	TCMXEE	ACB parameter	add radar	45
60	VANCEE	ACB parameter	add radar	38
61	VAXCEE	ACB parameter	add radar	45
62	VEHTYP	EEP_FIXED.VEHICLE_TYPE	new	2
63	VP15EN	EEP_FIXED.CAN_CONF_ETC7_VP15.B	new	1

10. Select **Generation** tab and then click on **Start Generation**.

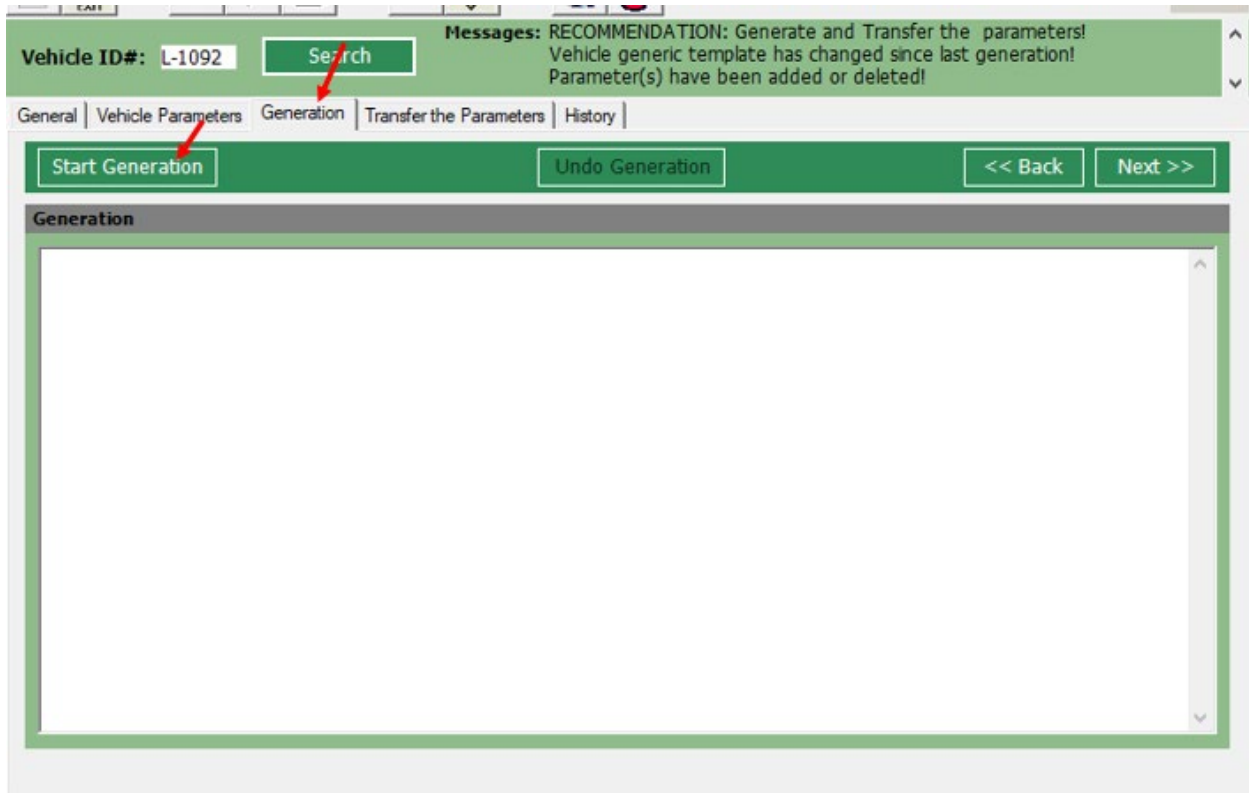

FIGURE 52

11. In the example below, the parameters file generated as an error i.e. the first parameter does not begin with an F. Do not transfer, select NO.

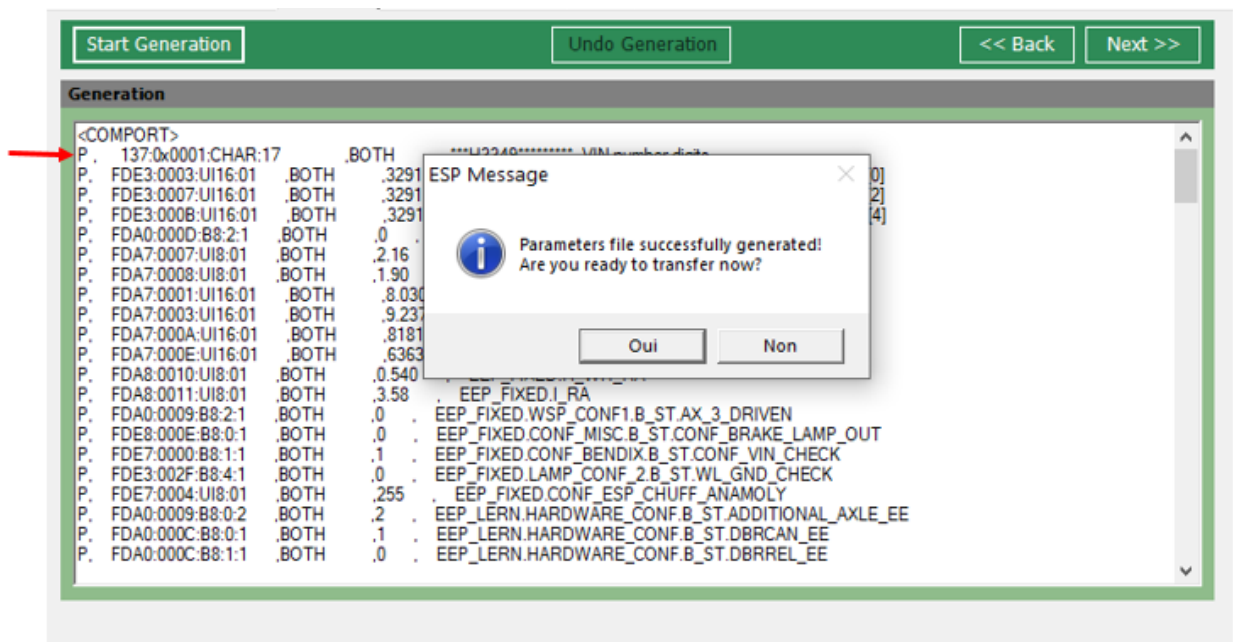

FIGURE 53

12. Generate de Parameter file once again by clicking on Start Generation. Check that all parameters listed begin with F. Click **NO**.

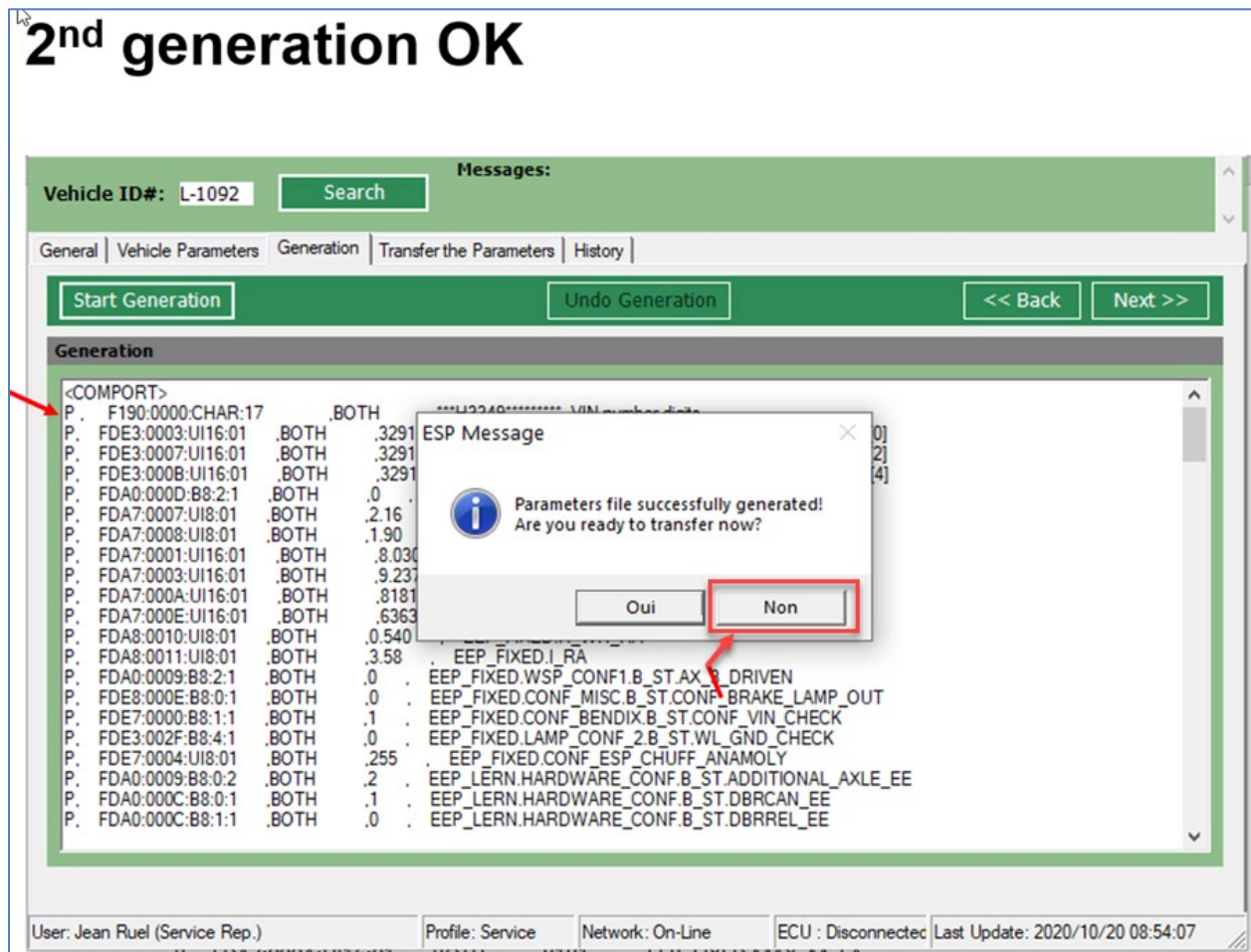

FIGURE 54

13. Select **Transfer the Parameters** tab. Select **Setting...**, then **VOCOM-1 J1939** and then **OK**.

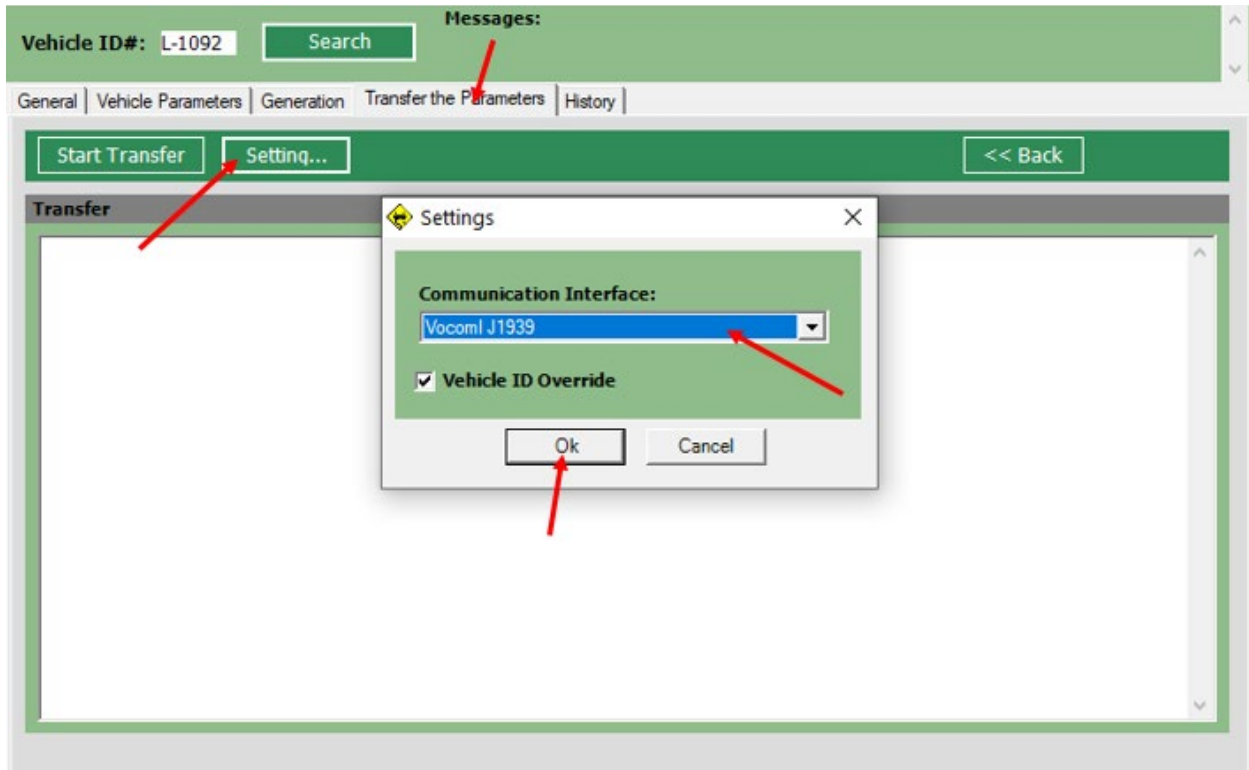

FIGURE 55

14. Select **Start Transfer**, then **OK**.

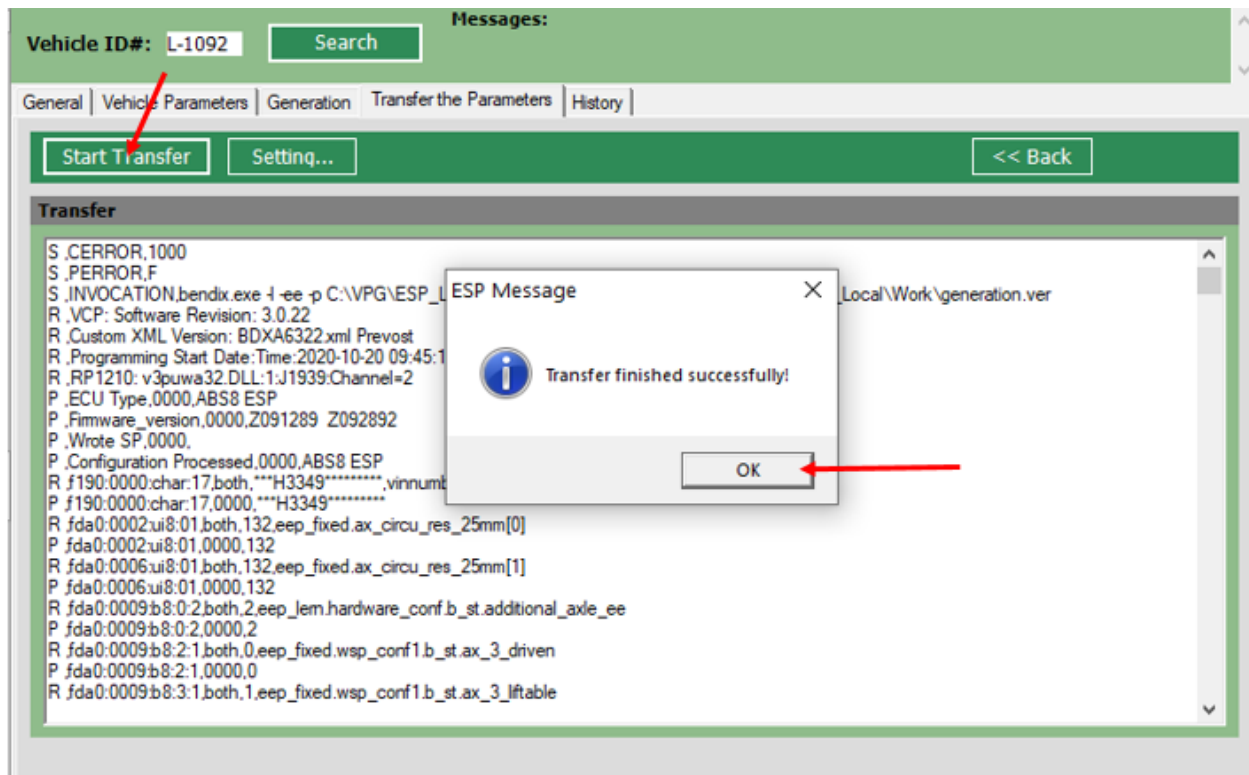

FIGURE 56

PREVOST

5.4. WITH FORMATION LAPTOP - Calibration of ESP sensors with Bendix ACOM software

1. Connect to Bendix ACom software.
2. Select: EC-80 CAN/J1939

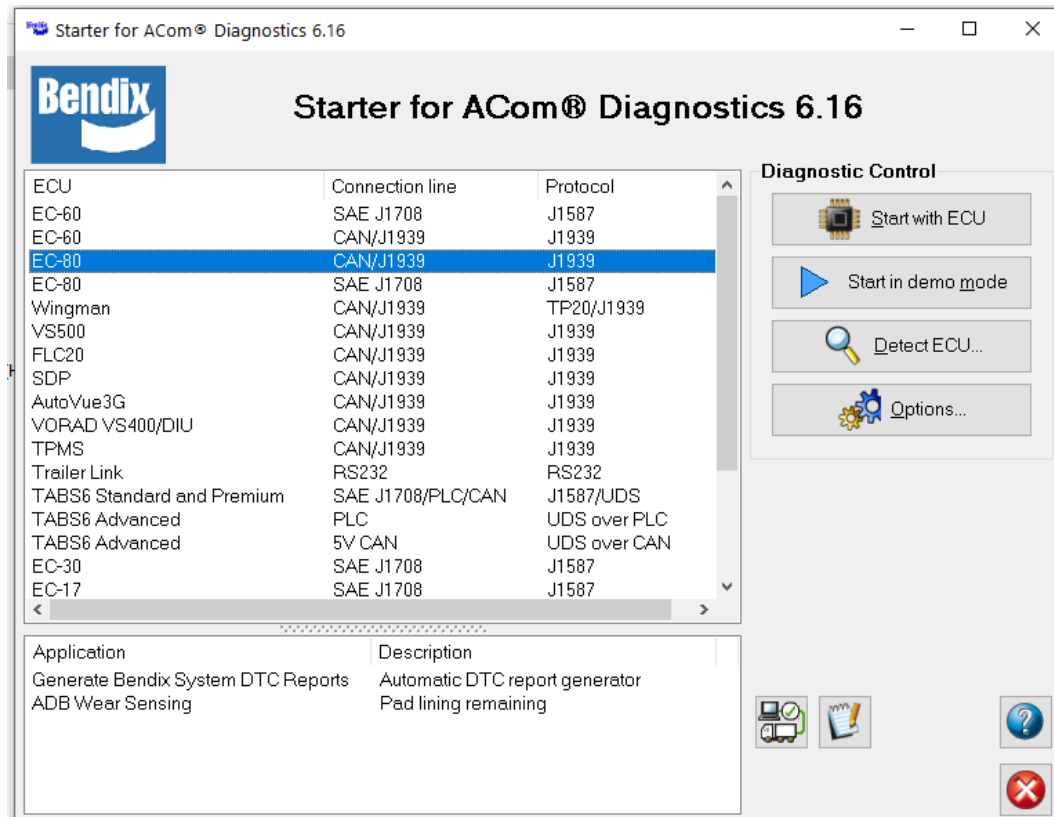

FIGURE 57

3. Select the appropriate communication hardware interface. In this case, VOCOM-1.

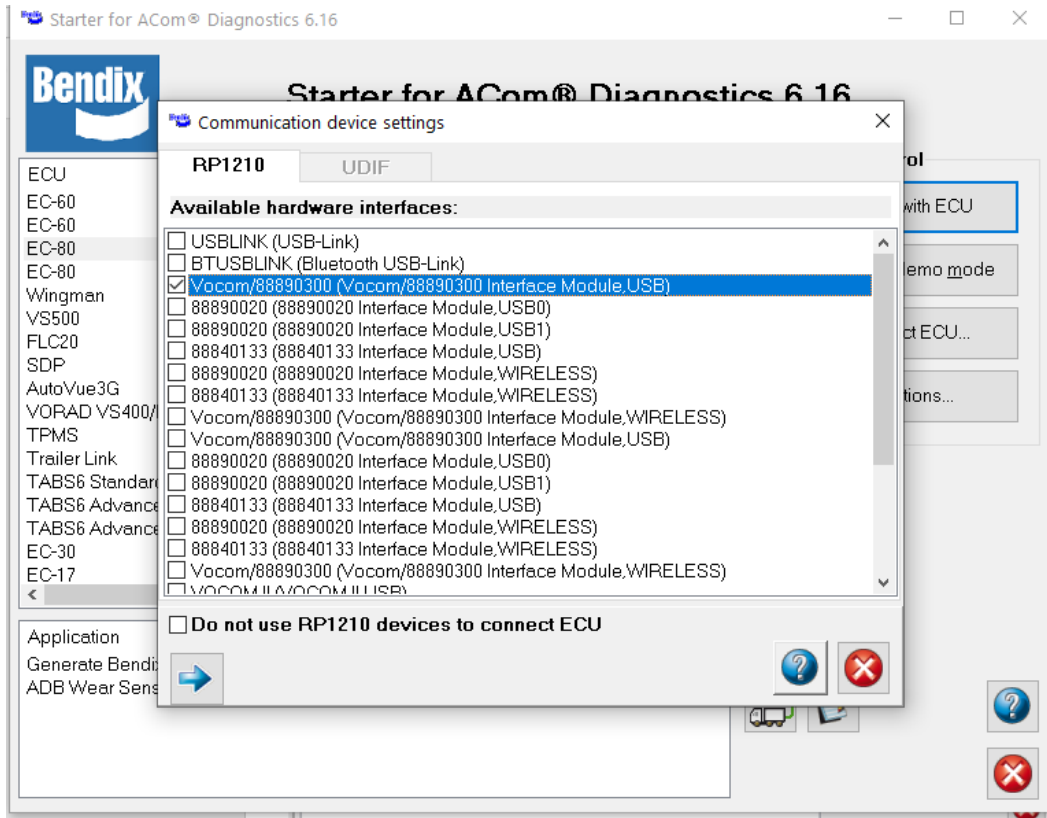

FIGURE 58

4. Select **CALIBRATE ESP SENSORS** tab and then **LATERAL ACCELERATION**. Click on **START**.

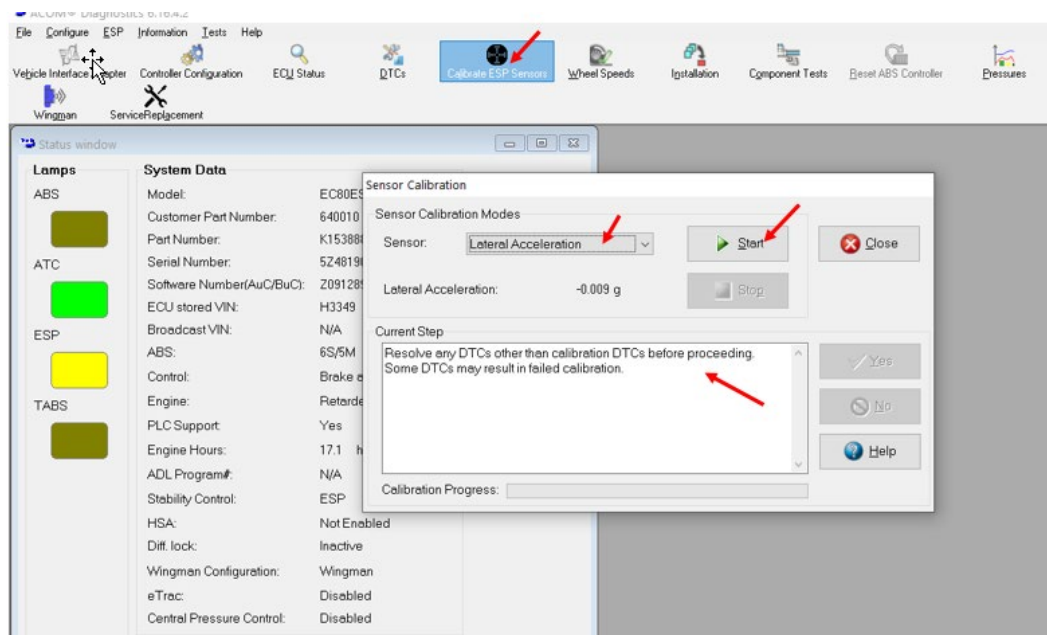

FIGURE 59

5. Read the current step message and validate.

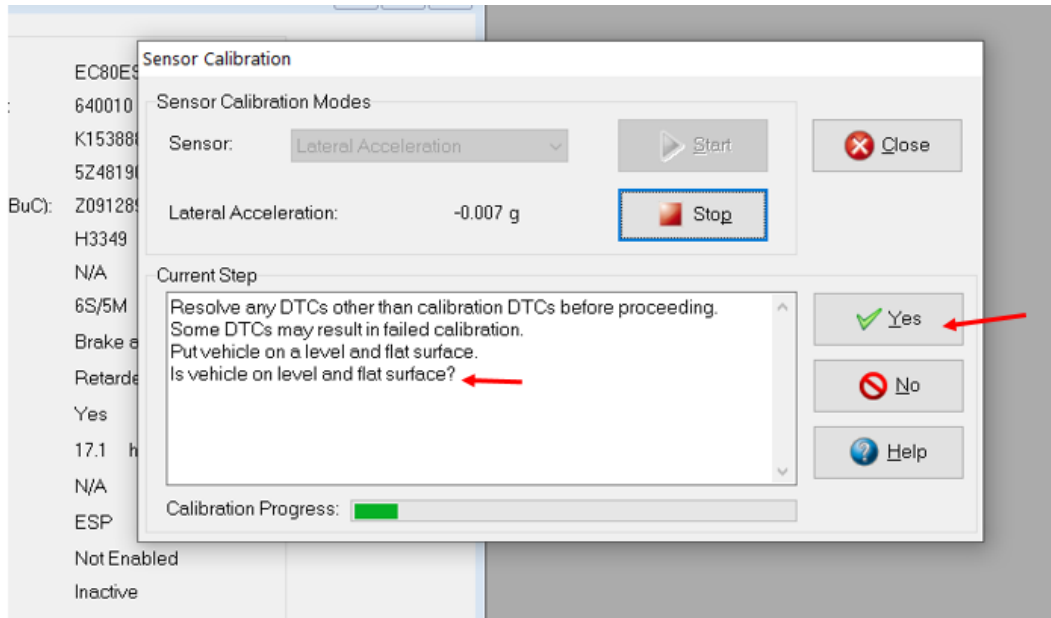

FIGURE 60

6. Select STEERING ANGLE. Click on START.

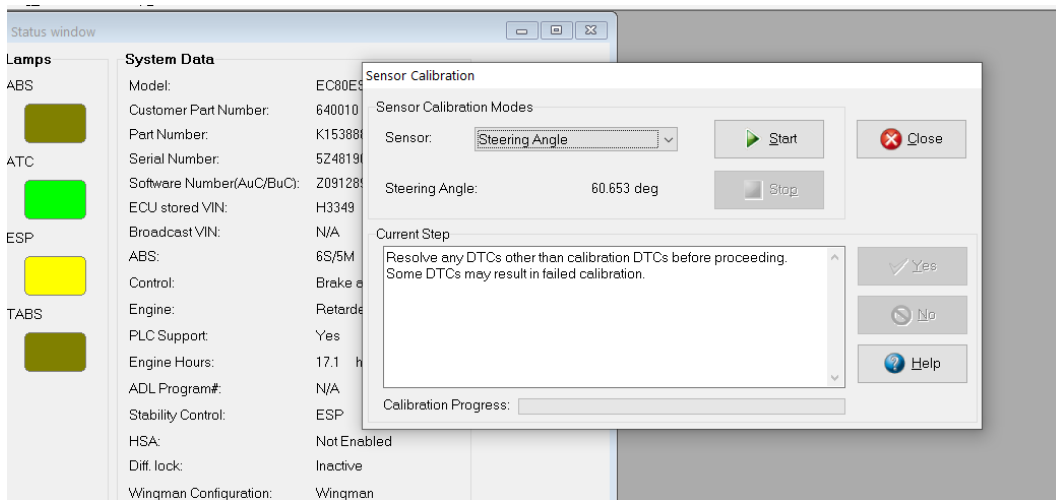

FIGURE 61

7. Read the current step message and validate.

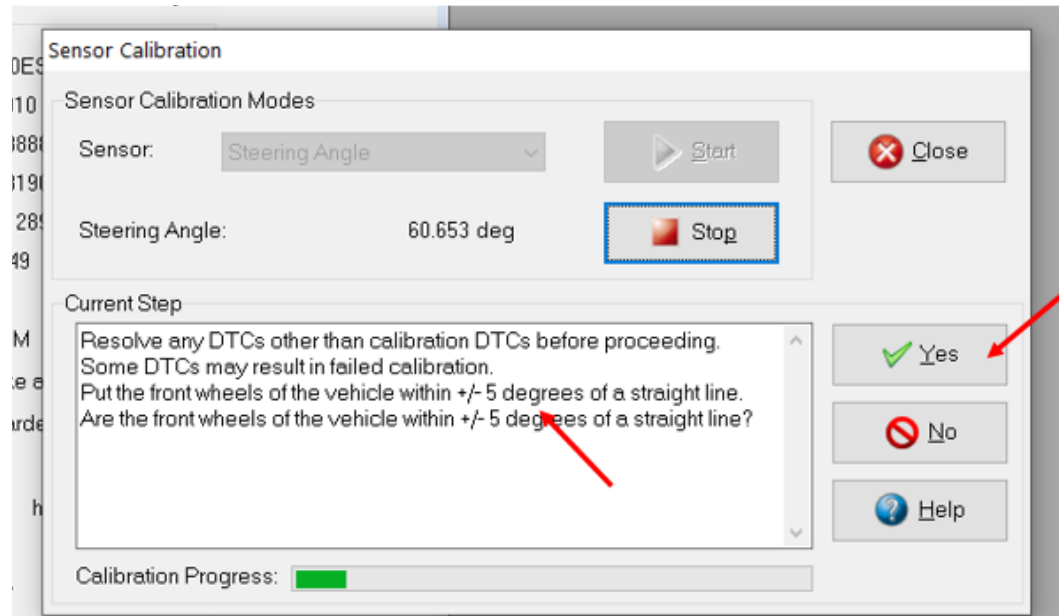

FIGURE 62

PREVOST

6. WINDSHIELD CAMERA CALIBRATION

Make sure that:

- a) The vehicle air pressure is normal
- b) The air springs are at normal ride height
- c) No one is present in the vehicle during the calibration
- d) The vehicle is parked on a flat and level surface
- e) The tag axle is in the normal ride position (lowered and air pressure applied)

6.1. Installation

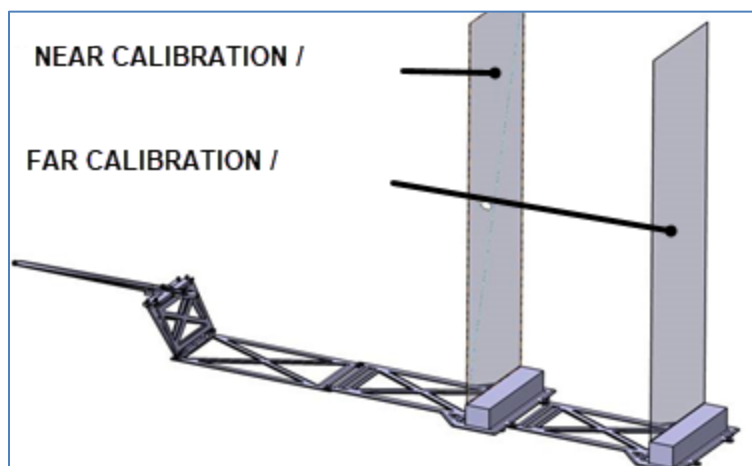
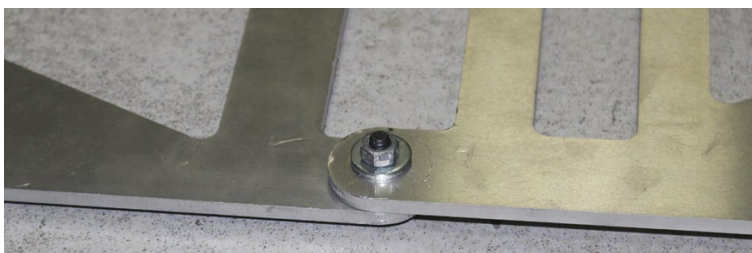
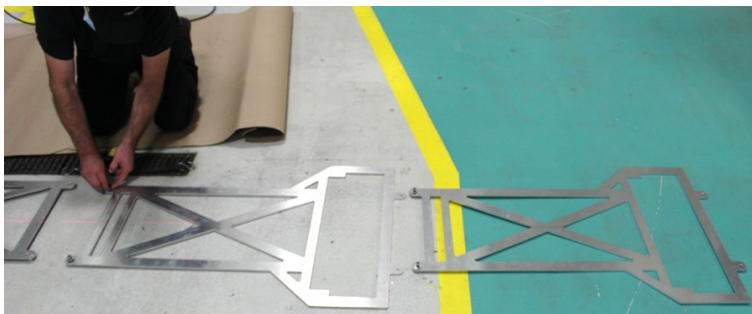

FIGURE 63: CALIBRATION TOOL G37363 AND TARGET SCREEN 640048

1. Assemble the calibration tool G37363 and calibration target screen 640048.



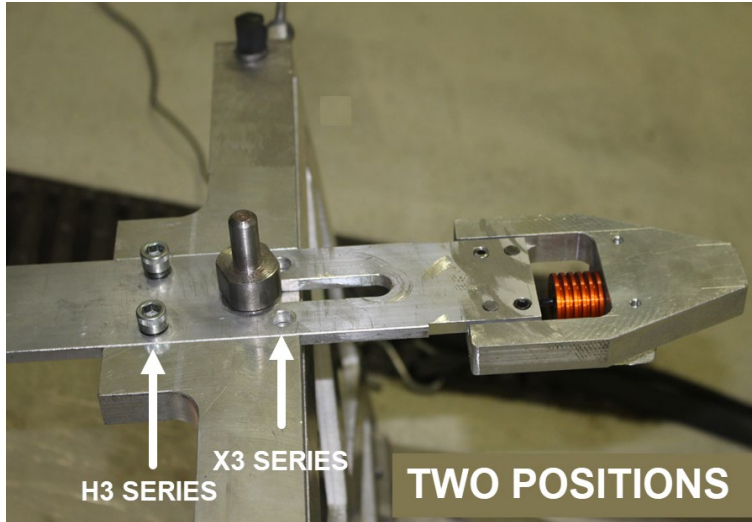

FIGURE 64

2. Connect the calibration tool to attachment points 1 & 2 on the coach.

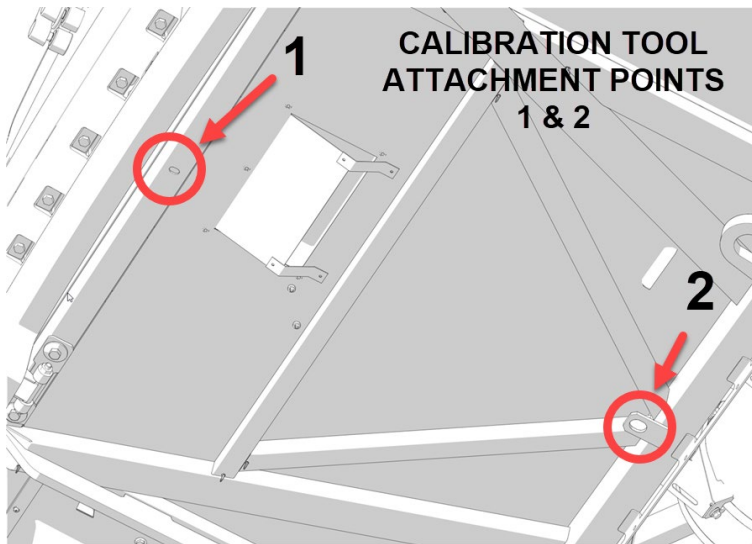

FIGURE 65

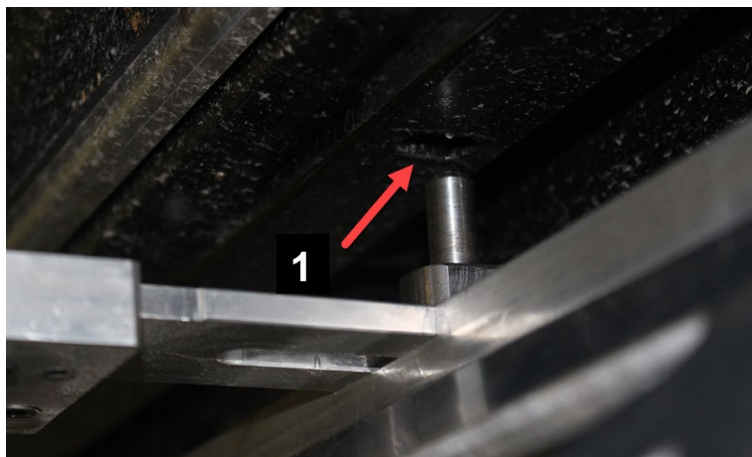

FIGURE 66: ATTACHMENT POINT 1

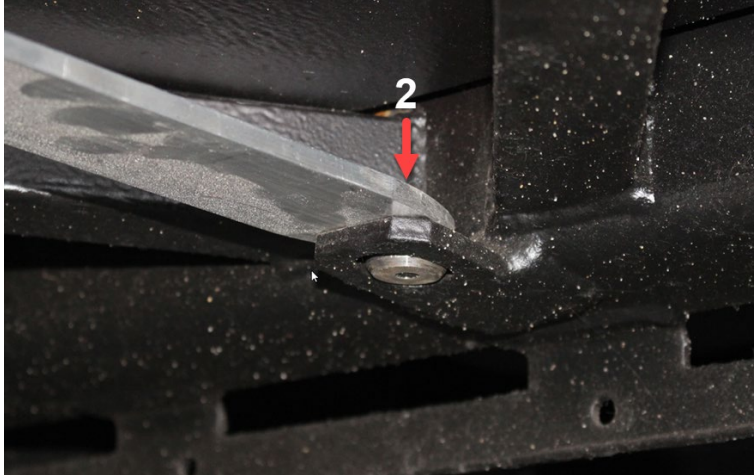

FIGURE 67: ATTACHMENT POINT 2

3. Install the hooked bungee tie.



FIGURE 68

4. Place a hydraulic bottle jack so that the tool stops will rest against the underframe.



FIGURE 69

5. Deploy the target to full height and install at the **NEAR CALIBRATION** point.

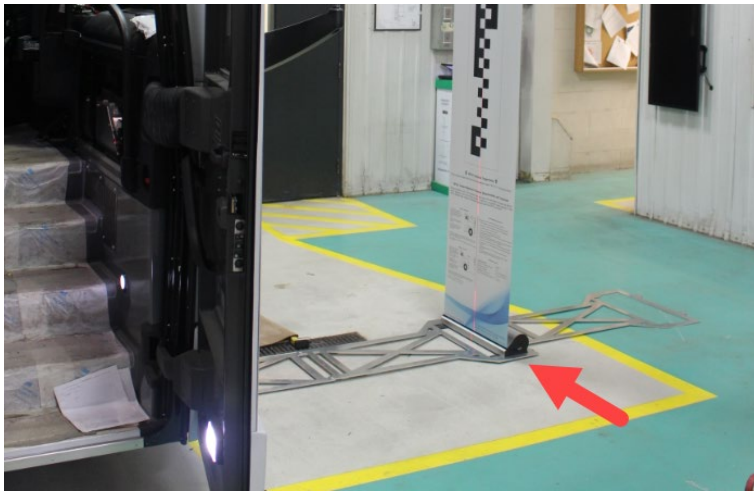

FIGURE 70

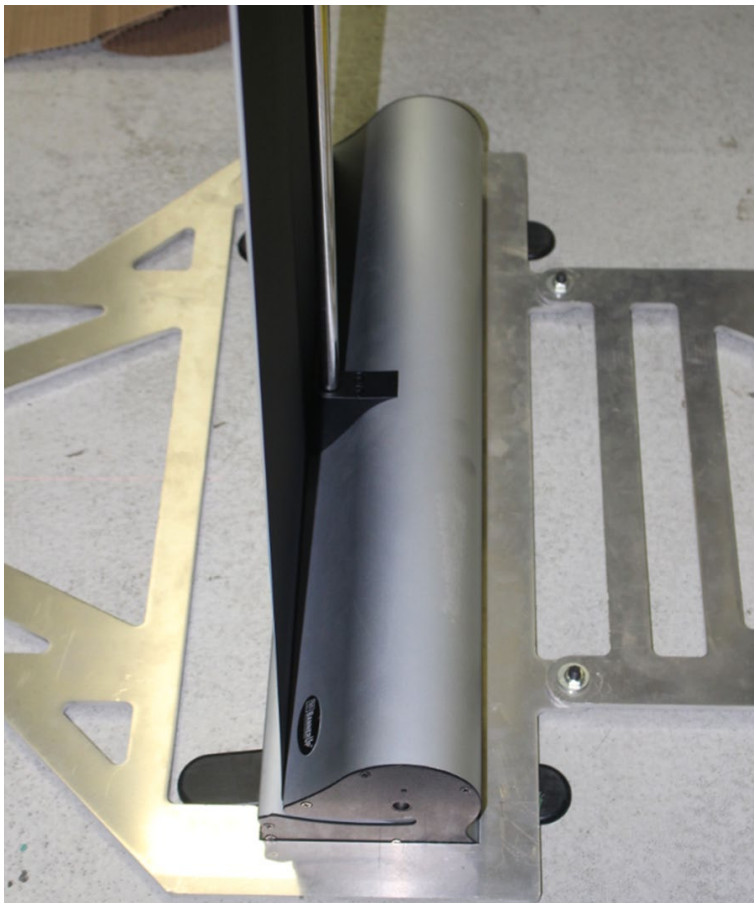

FIGURE 71

6. Make sure the adjustment tool is lined up with the laser beam i.e. in line with the longitudinal center line of the vehicle and that the target screen is parallel with the bumper.



FIGURE 72

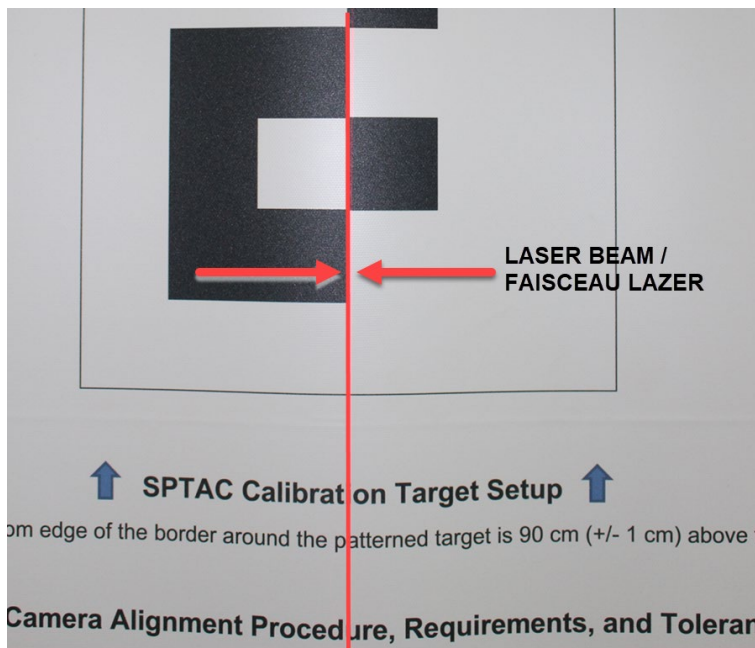

FIGURE 73

LATERAL TOLERANCE



Near: +/- 30 mm

Far: +/- 50 mm

7. Provide sufficient lighting on the front of the target and ambient lighting on the background.

PREVOST

6.2. WITH FORMATION LAPTOP - Calibration with SPTAC software

8. Open SPTAC software. To do so, double-click the icon or double-click the exe file.

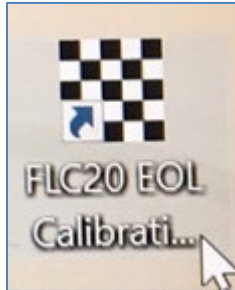

FIGURE 74

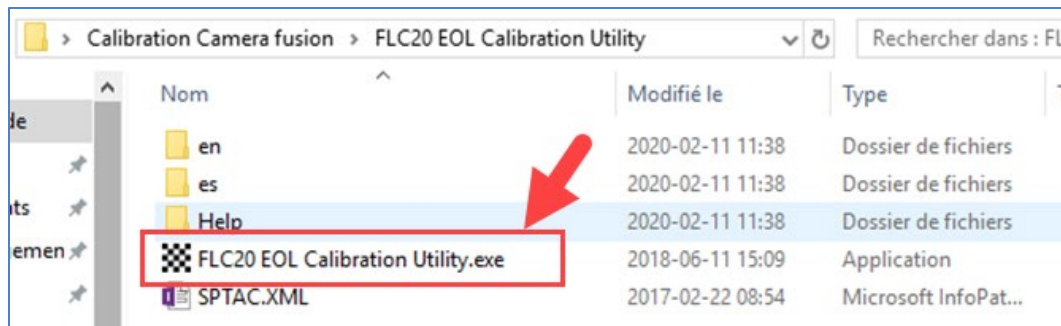

FIGURE 75

9. Read the following message and confirm.

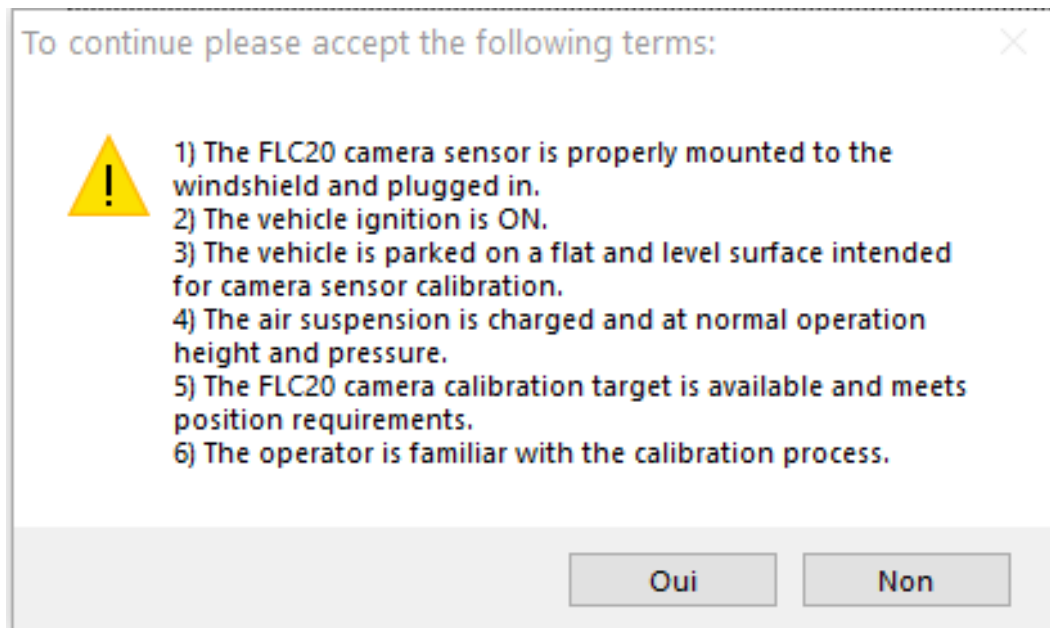

FIGURE 76

10. Click on SETTING.

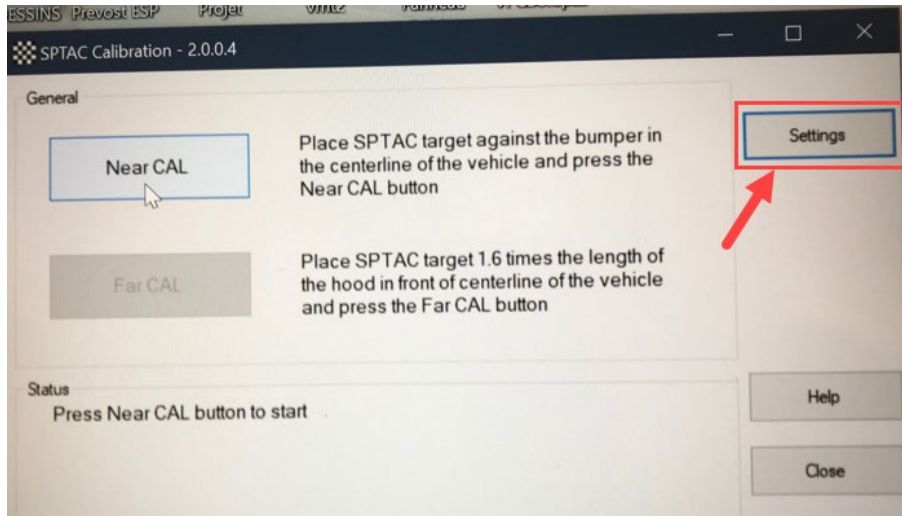

FIGURE 77

11. Select the communication interface used, which is VOCOM-1.

12. Select J1939:Channel=2

13. Enter the calibration saving path (Output Path).

Output path: \\multiplex.data.scr.volvo.net\webdata\prod\vpg\esp\outbox

14. Click on SAVE.

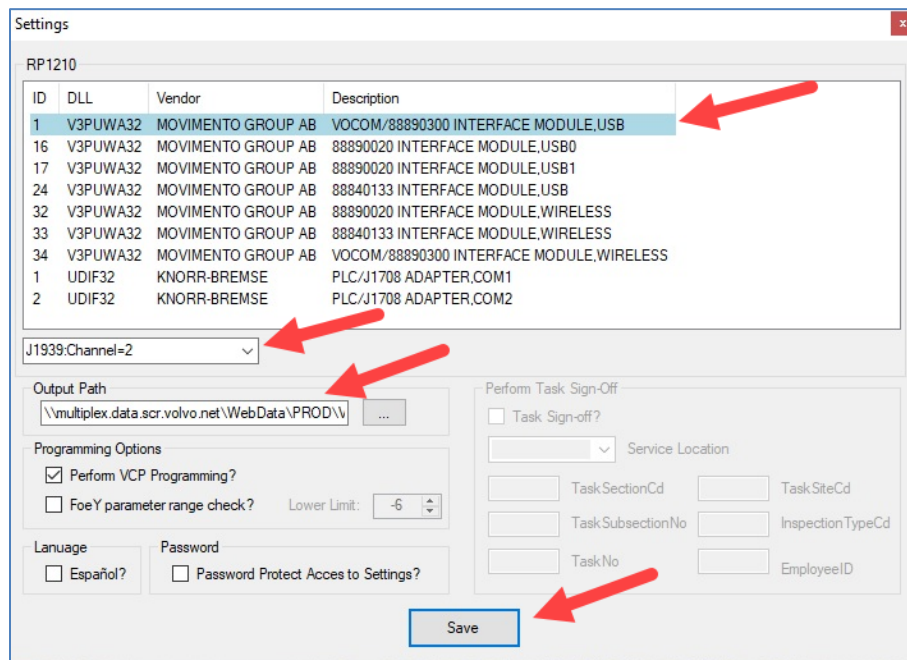

FIGURE 78

15. Start with the near calibration. Select **Near Cal**.

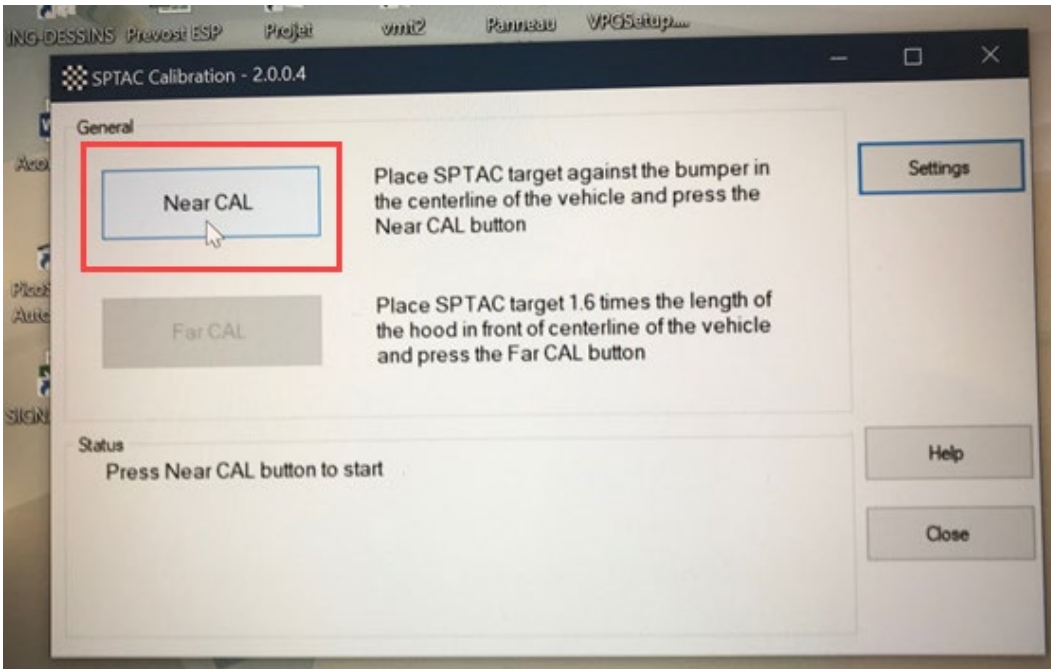

FIGURE 79

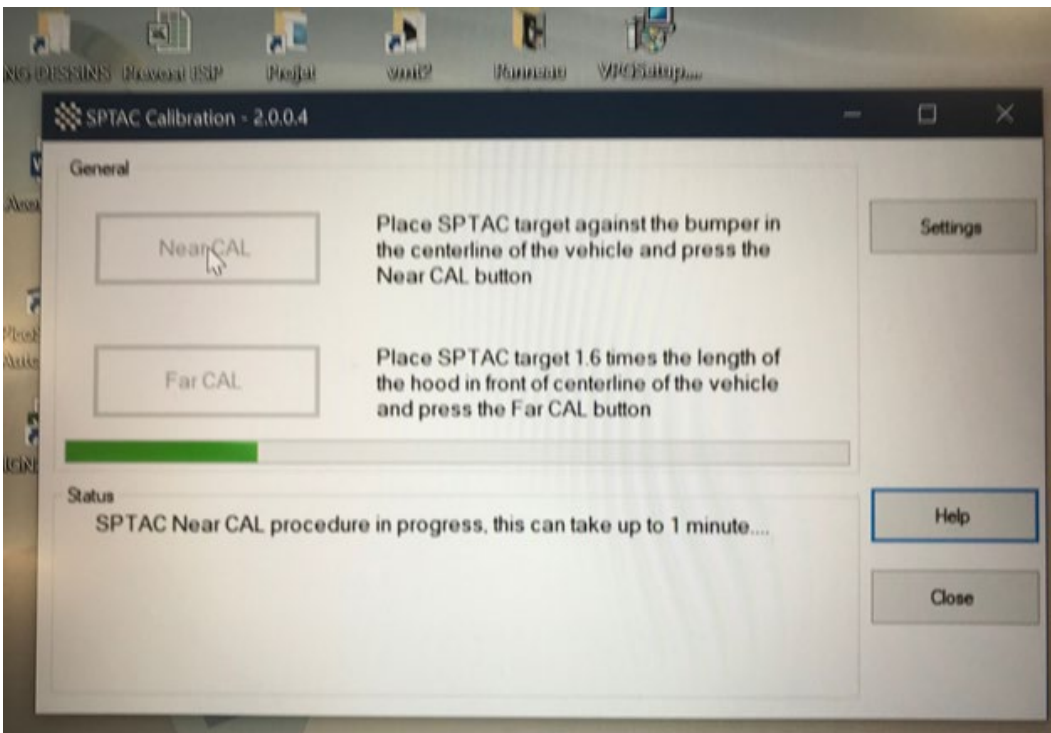

FIGURE 80

16. Wait for message **Near CAL** procedure passed.

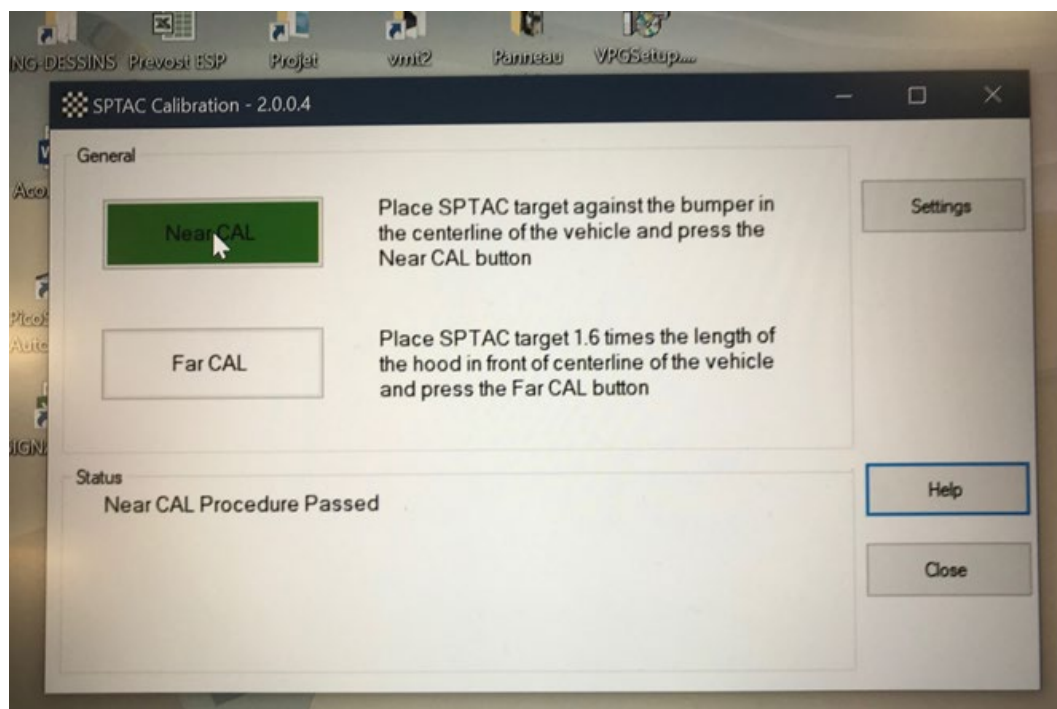

FIGURE 81

17. Deploy the target to full height and install at the FAR CALIBRATION point.

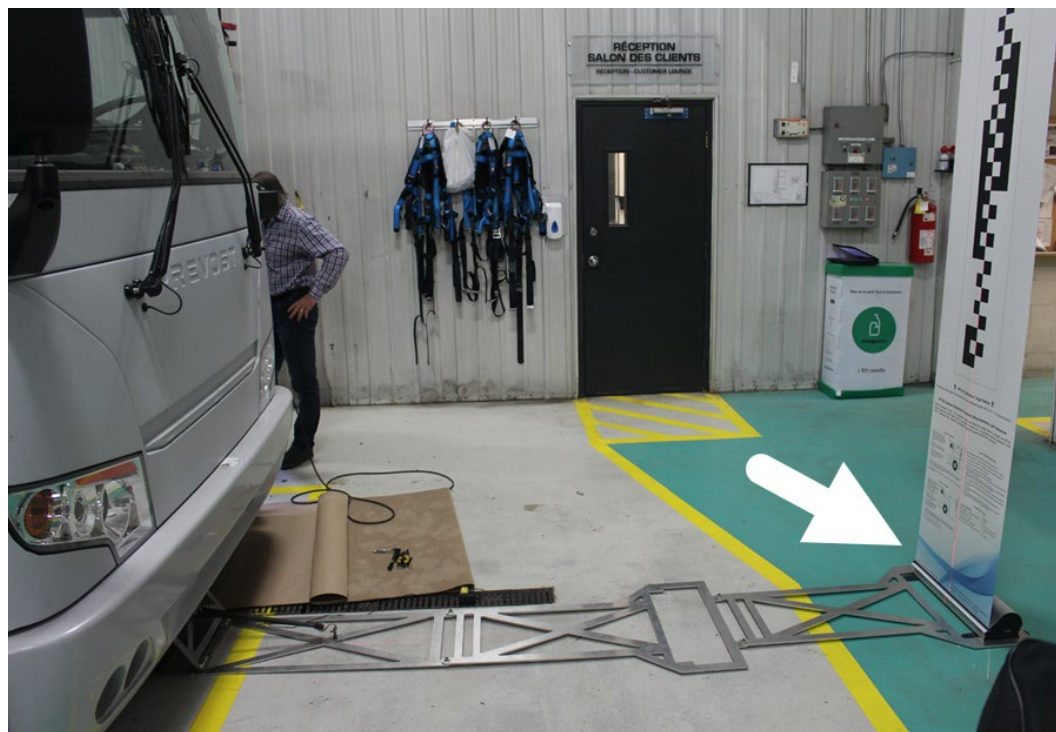

FIGURE 82

18. Select **Far Cal**.

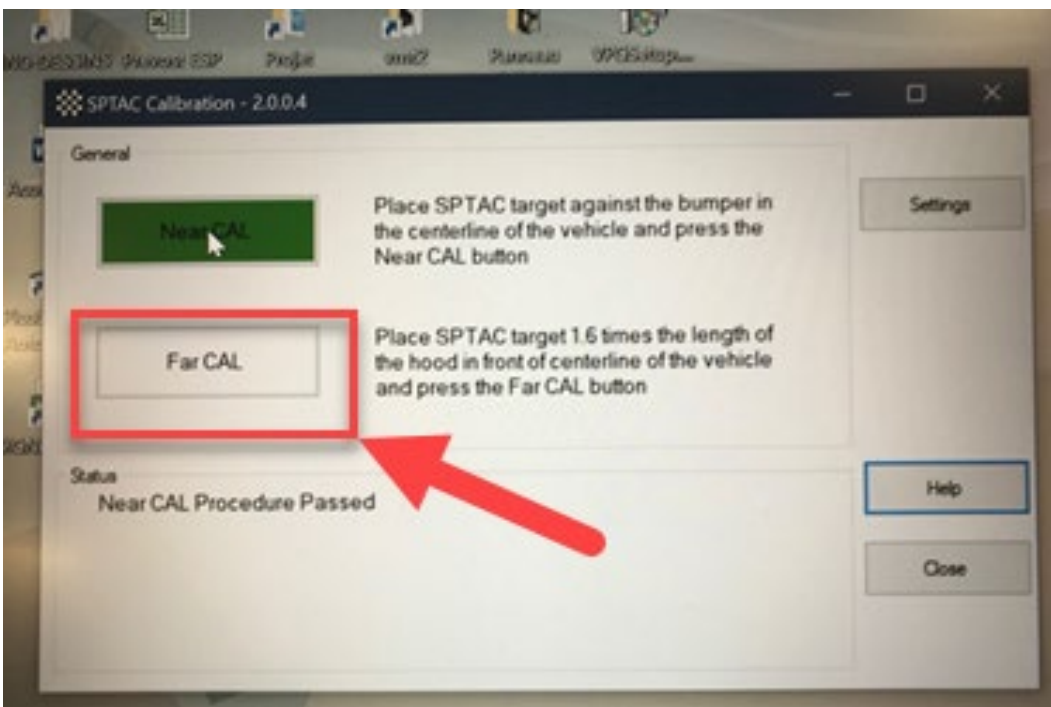

FIGURE 83

19. Wait for the calibration file to be saved on ESP folder for that specific vehicle for future ECU replacement.

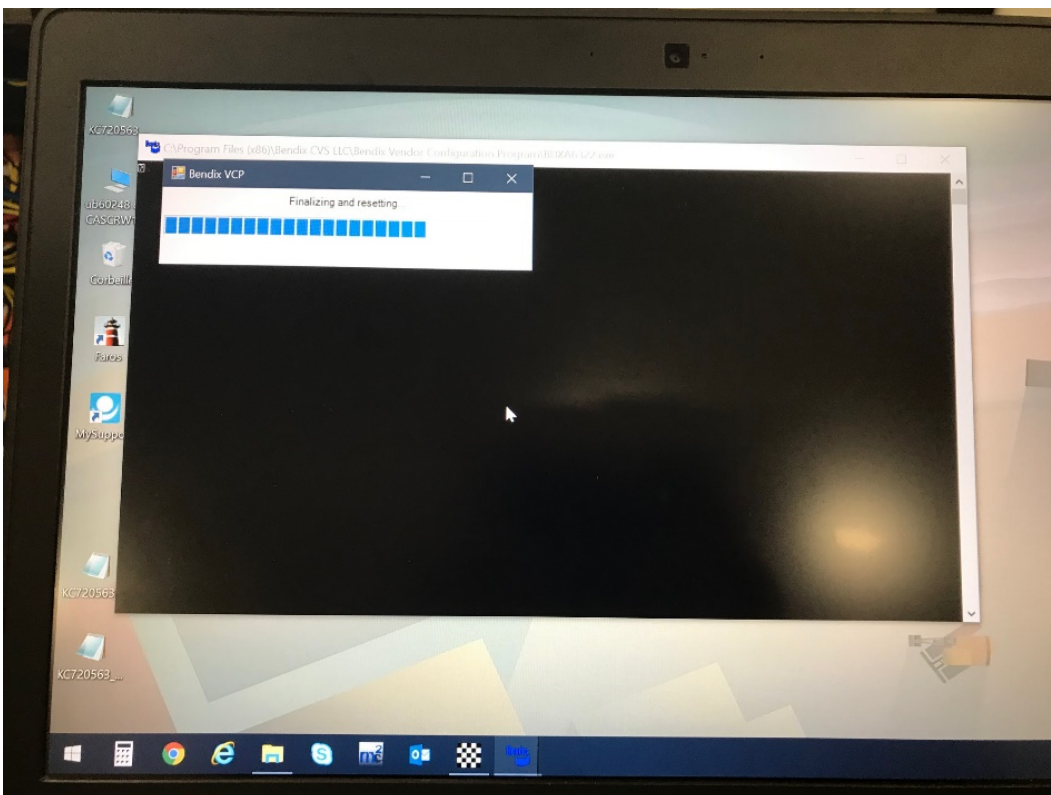

FIGURE 84

20. Calibration process completed. Status is **Calibration Completed Successfully**.

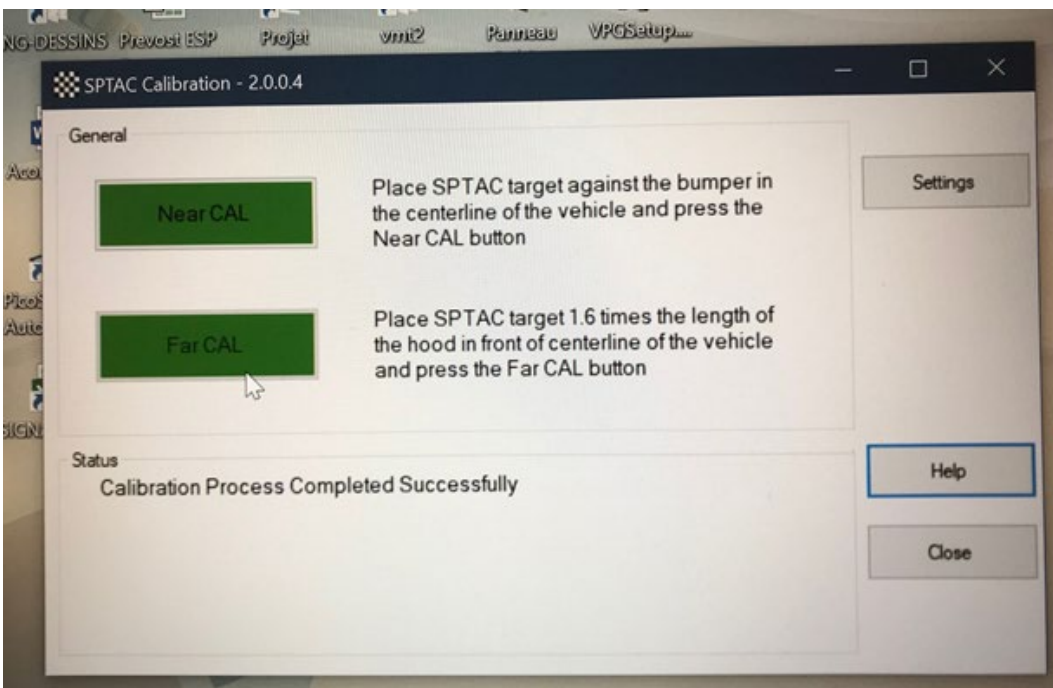

FIGURE 85

7. PARTS / WASTE DISPOSAL

Discard waste according to applicable environmental regulations (Municipal/State[Prov.]/ Federal)

PREVOST

8. APPENDIX A

8.1. ELECTRONIC MODULES CONNECTOR

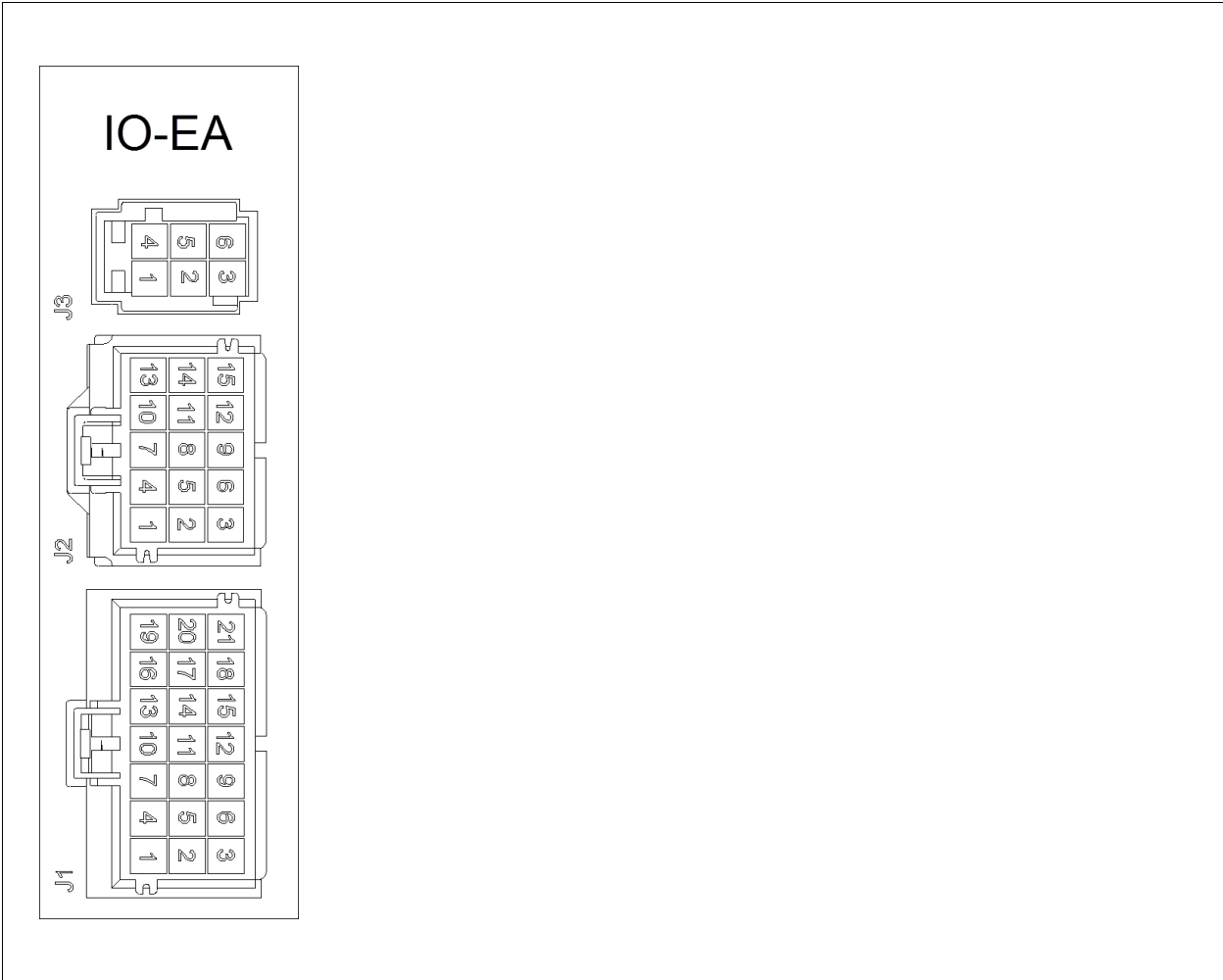
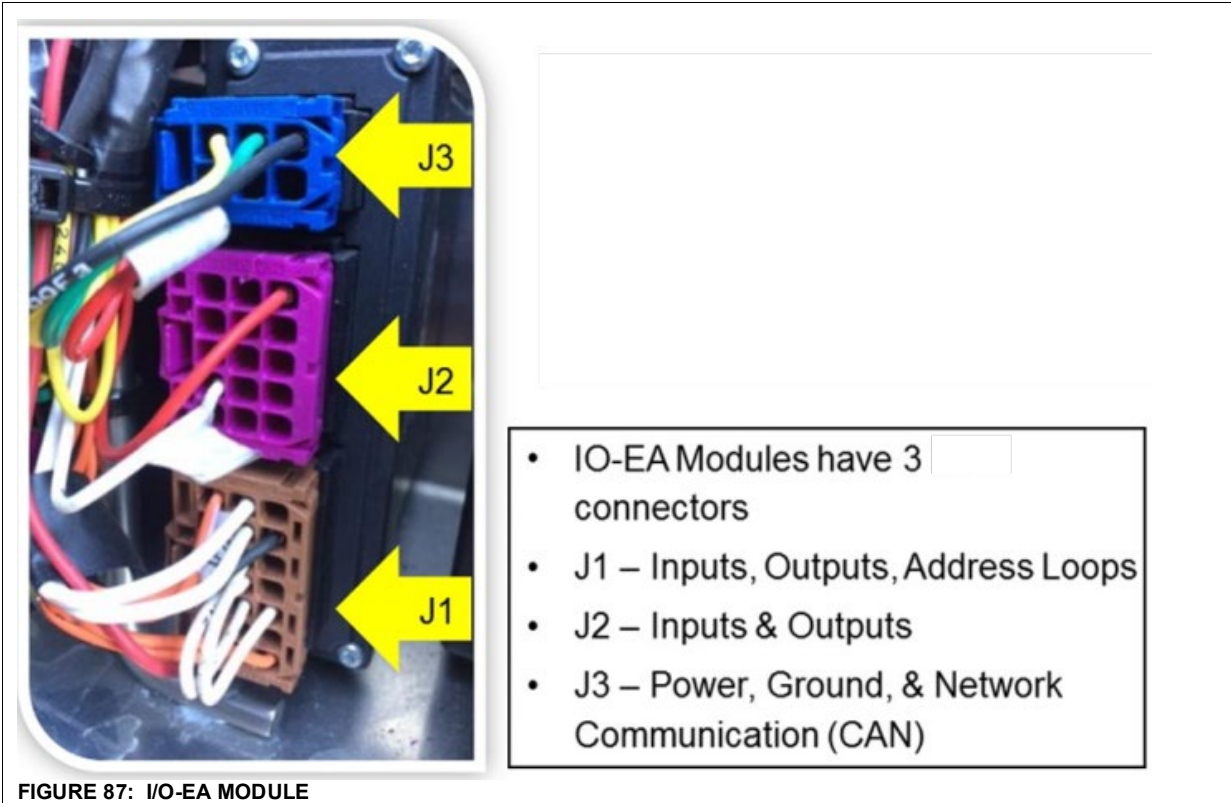
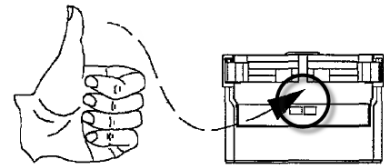

FIGURE 86: ELECTRONIC MODULE CONNECTOR PIN-OUT - BACK PROBING VIEW



I/O-EA & I/O-EB MUX modules Connector: AMP MCP 2.8	
<p>Contact loading of housings</p> <p>Loading the contacts is only possible if the secondary lock is in the unlock position.</p> <p>Proper orientation of the contact is important. If the orientation is incorrect, the contact stops too early in the region of the secondary lock and the whole crimp stands out from the housing. With correct orientation, the secondary lock stops with a metallic “click” sound.</p>	
<p>Locking the secondary lock</p> <p>Delivery state of the secondary lock is the open position. In this position, the AMP MCP2.8 contacts can be loaded. After that the secondary lock is moved into the final locking position by hand.</p> <p>At a sufficient large surface a perpendicular force is initiated by (preferably) the thumb of one hand. Proper final</p>	<p style="text-align: center;">UNLOCKED LOCKED</p>

position is reached a click noise can be heard. Make sure that both sides are locked.



Unlocking the secondary lock

To unlock the secondary lock on these housings, a simple solid commercial ball pen is sufficient. The ball pen has to be inserted perpendicularly according the image, between the locking latch of the housing and the secondary lock block. Then it will be pushed with care until the opening is felt (a "click" sound can be heard).

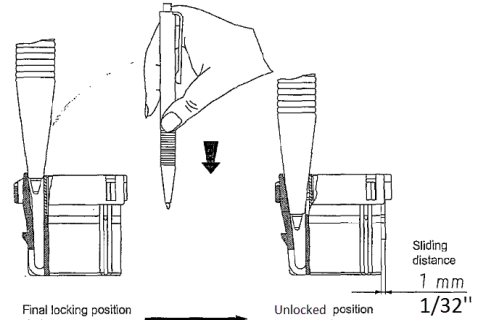
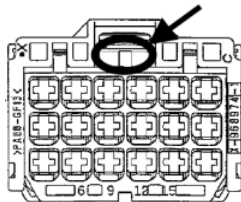

Extracting the contacts from housings

To extract contacts, the secondary lock has to be in the un-lock position. The tool has to be inserted from connection side into the cavity of housing up to the stop; the contact will be unlocked thereby. Keep the tool in that position and then take the contact out by pulling on the cable. Note: Do not pull the cable before unlocking the contact; on the other hand by pressing the cable gently against the cable outlet direction the unlocking procedure will be facilitated.



EXTRACTOR/TOOL: Prevost 568103

8.2. DEUTSCH DT CONNECTOR

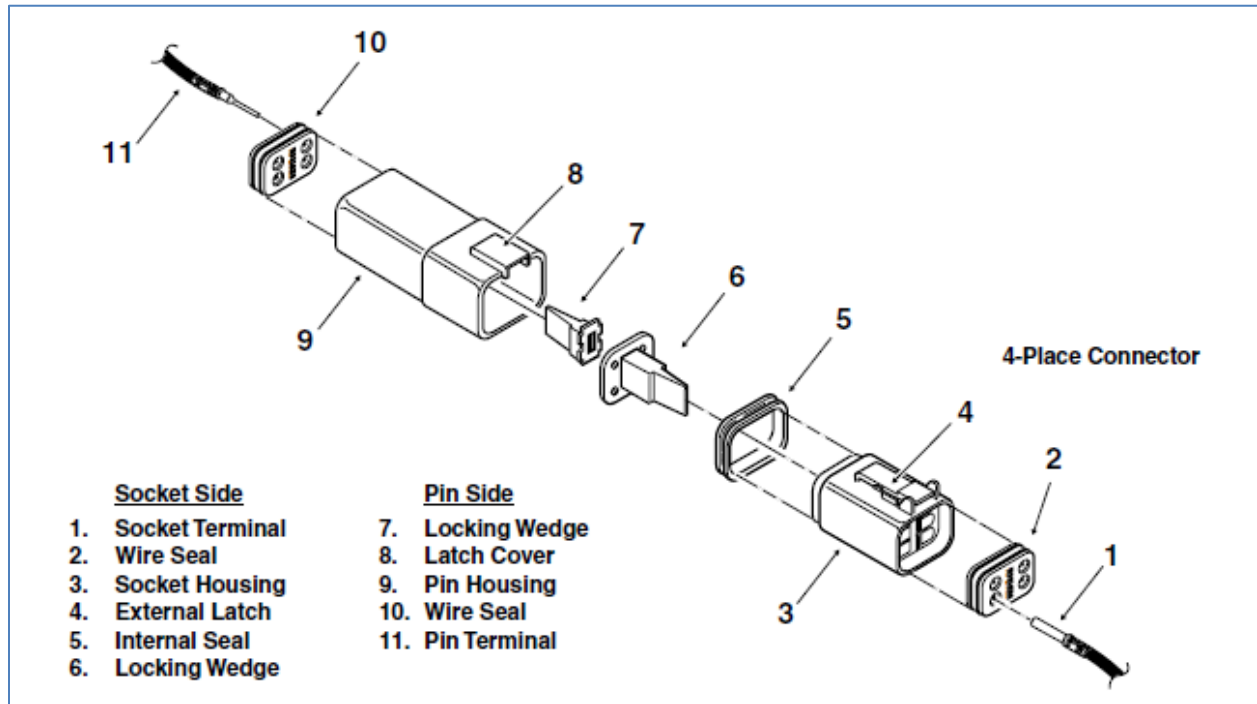

DT Series Technical Manual



Assembly Contact Insertion (DTM, DT, DTP)



1. Grasp crimped contact approximately 1.0" (25.4mm) behind the contact barrel.



2. Hold connector with rear grommet facing you.



3. Push contact straight into connector grommet until a click is felt. A slight tug will confirm that it is properly locked in place.

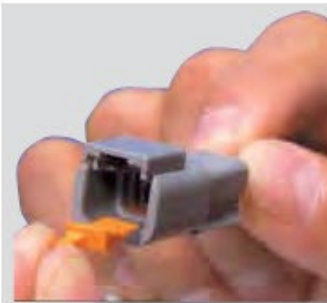

4. Once all contacts are in place, insert orange wedge: receptacles - with half holes aligning with contacts. Plugs - with contacts aligning behind full holes. The orange wedge will snap into place.

NOTE: The receptacle is shown - use the same procedure for plug.

Contact Removal



1. Remove orange wedge using needle-nose pliers to pull wedge straight out.

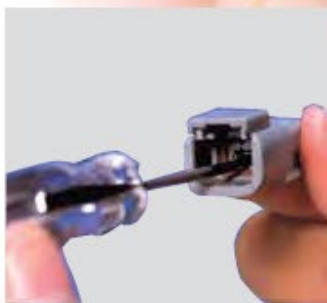

2. To remove the contacts, gently pull wire backwards, while at the same time releasing the locking finger by moving it away from the contact with a screwdriver.



3. Hold the rear seal in place, as removing the contact will displace the seal.

8.3. JAE CONNECTOR

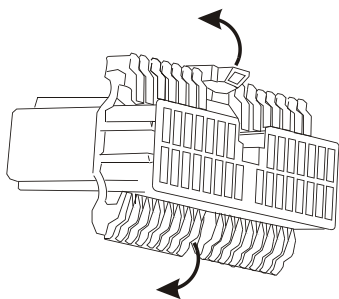

green, blue

JAE CONNECTOR

EXTRACTOR/TOOL: Prevost #683766

Using a small flat blade screwdriver, open both hinged secondary locks. Insert the extractor on the front of the connector, over the terminal cavity. Remove the terminal by disengaging the flexible lock tab on the terminal. Gently remove the terminal from the connector by pulling on the wire.