



Technical Service Bulletin

26 Noises are heard from the exhaust at idle, DTCs P047600, P048C00, P04A000, or P301B00 are stored in the ECM

26 21 45 2058998/3 May 18, 2021. Supersedes Technical Service Bulletin Group 26 number 21-44 dated February 1, 2021 for reasons listed below.

Model(s)	Year	VIN Range	Vehicle-Specific Equipment
RS 6 Avant, RS 7	2020 - 2021	All	Not Applicable
RS 5, RS 5 Cabriolet, and RS 5 Sportback	2019, 2021	All	Not Applicable

Condition

REVISION HISTORY		
Revision	Date	Purpose
3	-	Revised header (Updated with applicable 2020/2021 vehicles) Revised <i>Technical Background</i> (Added information) Revised <i>Service</i> (Updated Step 1)
2	2/1/2021	Revised title (Added DTCs) Revised header (Updated with applicable 2020/2021 vehicles) Revised <i>Service</i> (Updated Steps) Revised <i>Additional Information</i> (Added reference)
1	03/24/2020	Initial publication

Customer states:

- Noises are heard from the exhaust system.

Workshop findings:

- A rattling, twittering or bubbling noises can be attributed to the exhaust flap in the rear silencer – mainly audible at idle speed and with closed exhaust flap. The noise can be changed or located by touching the exhaust flap or the exhaust flap mounting.

The following DTCs may be stored in the engine control module (ECM), J623 (address word 0001) related to the exhaust flap:

- DTC P047600** or **DTC P04A000** (Pressure Control Valve "A" Range/Performance).
- DTC P048C00** or **DTC P301B00** (Exhaust flap sensor bank 1/2, implausible signal).



Technical Service Bulletin

Technical Background

The play in the exhaust flap mechanism can be affected by age and exposure to the elements. As a result there can be concerns related to noises from the exhaust system, particularly after a cold start.

Loud creaking noises when the exhaust flaps are activated (during closing) are caused by the exhaust flap control motor.

Production Solution

An optimized rear silencer was developed and put into production. Some vehicles are already fitted with the optimized rear silencer (factory-fitted, with claw coupling and spring lock), but still have an old control motor (part number 8S0 133 246 A).

Service

1. For an example of the sound of normal operations, see the video located at: <https://audi-external.kzopplatform.com/player/medium/1872761570556122175> (Figure 1).
 - If the sounds of shifting/working noise of the control motor and the exhaust flap are similar to the customer's vehicle then no repairs need to be made.
 - Please also refer to the service info on normal exhaust flap/operating noises from the control motor in TSB 2062029: *26 Creaking noises are heard from exhaust flap at idle speed - V6 2.9TFSI*.
 - If the noises from the customer's vehicle sound very different, then continue following the instructions in this TSB.
2. First check which rear silencer is fitted to the customer's vehicle, making a distinction as follows:
 - A. Old version (Figure 2): C-bracket (marked yellow) and moveable bearing (blue). **It is not compatible with an optimized control motor.** The complete rear silencer has to be replaced.



Figure 1. QR code for viewing the supporting video.



Technical Service Bulletin

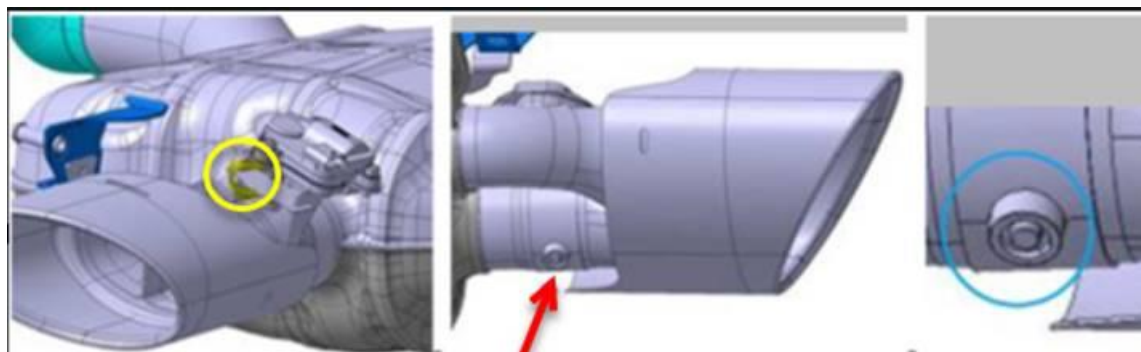

Figure 2. Old rear silencer.

- B. Optimized version (Figure 3): claw coupling (marked yellow) with spring lock (blue). Check which version of the control motor is fitted: If the control motor fitted is not the new version (part number 8S0 133 246 D), replace it individually on the exhaust flap with the concern.

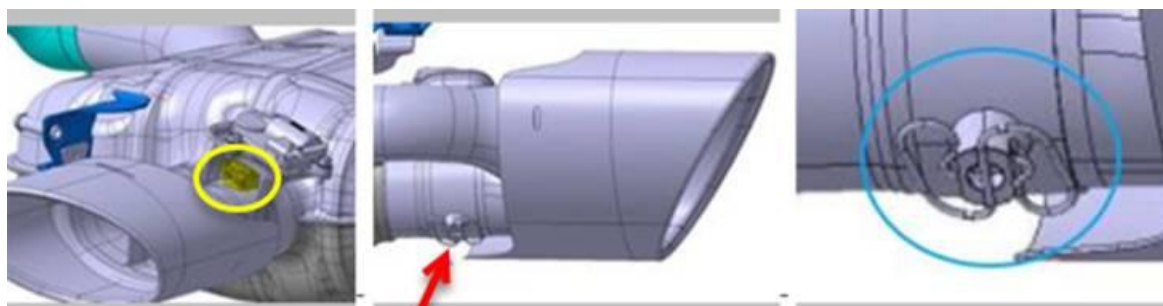

Figure 3. The optimized version of the rear silencer.

- C. Loud creaking noise on versions that were already optimized.

If the optimized version of the rear silencer and control motor is already fitted and there is a concern related to a loud creaking sound from the exhaust flap when closing (video above for normal operation), you may replace the affected control motor on the affected side. It is not necessary to replace the entire rear silencer.

3. Record a video of the noise concern and upload it to DOC-IT.



Note:

Warranty claims related to this noise concern can only be invoiced when a sound recording of the noise on the affected vehicle is uploaded in DOC-IT. We reserve the right to reject any claims that do not include a recording of the noise.

4. If the customer's vehicle is has a creaking sound then refer to TSB 2062029: *26 Creaking noises are heard from exhaust flap at idle speed - V6 2.9TFSI* for more information

If the customer's vehicle has a sound outside of both of these bulletins, then locate the cause of concern and repair it accordingly outside of these TSBs.



Technical Service Bulletin

Warranty

Claim Type:	<ul style="list-style-type: none"> • 110 up to 48 Months/50,000 Miles. • If the vehicle is outside any warranty, this Technical Service Bulletin is informational only. 		
Service Number:	2633		
Damage Code:	0020		
Labor Operations:	Remove and install 1 rear muffler or 2 rear mufflers	2633 1900 Or 2633 2000	See SRT with associated operations
	Remove and install 1 exhaust flap or 2 exhaust flaps	2671 1900 Or 2671 2000	See SRT with associated operations
Diagnostic Time:	GFF – Checking and clearing fault codes included in existing labor operations	0150 0000	Time stated on the diagnostic protocol (Max 50 TU)
	Road test prior to the service procedure	No allowance	0 TU
	Road test after the service procedure	No allowance	0 TU
Claim Comment:	As per TSB #2058998/3		

All warranty claims submitted for payment must be in accordance with the *Audi Warranty Policies and Procedures Manual*. Claims are subject to review or audit by Audi Warranty.

Required Parts and Tools

Always check with your Parts Department and/or ETKA for the latest information and parts bulletins.		
Part Number	Part Description	Quantity
See ETKA	Fasteners, Bolts, Nuts, and Screws as needed per the Repair Manual	See ETKA/ELSA
See ETKA	Rear Muffler - Right	01
See ETKA	Rear Muffler - Left	01



Technical Service Bulletin

8S0133246D	Control Motor	01 or 02
------------	---------------	----------

Additional Information

The following Technical Service Bulletin(s) will be necessary to complete this procedure:

- TSB 2062029, *26 Creaking noises are heard from exhaust flap at idle speed - V6 2.9TFSI.*

All parts and service references provided in this TSB (2058998) are subject to change and/or removal.

©2021 Audi of America, Inc. All rights reserved. The information contained in this document is based on the latest information available at the time of printing and is subject to the copyright and other intellectual property rights of Audi of America, Inc., its affiliated companies and its licensors. All rights are reserved to make changes at any time without notice. No part of this document may be reproduced, stored in a retrieval system, or transmitted in any form or by any means, electronic, mechanical, photocopying, recording, or otherwise, nor may these materials be modified or reposted to other sites without the prior expressed written permission of the publisher.