

Technical Service Bulletin

Mazda North American Operations
Irvine, CA 92618-2922



Subject: CHECK ENGINE LIGHT ON WITH DTC P0524 OR P055F	Bulletin No.: 01-004/21
	Last Issued : 04/30/2021

BULLETIN NOTE

This bulletin supersedes the previously issued bulletin(s) listed below. The changes are noted in Red text.

Previous TSBs:	Date(s) Issued:
01-004/21	02/05/21

APPLICABLE MODEL(S)/VINS

- 2018-2020 CX-5 2.5L (with cylinder deactivation) vehicles with VINs lower than JM3KF*****869654 (produced before Aug. 24, 2020)
- 2021 CX-5 2.5L (with cylinder deactivation and 8" center display) vehicles with VINs lower than JM3KF*****120983 (produced before Dec. 14, 2020)
- 2021 CX-5 2.5L (with cylinder deactivation and 10.5" center display) vehicles with VINs lower than JM3KF*****358113 (produced before Dec. 14, 2020)
- 2020-2021 CX-30 2.5L (with cylinder deactivation) vehicles with VINs lower than 3MVDM*****239819 (produced before Dec. 23, 2020)
- 2019-2020 Mazda3 2.5L (Japan built, with cylinder deactivation) vehicles with VINs lower than JM1BP*****176405 (produced before Apr. 2, 2020)
- 2019-2021 Mazda3 2.5L (Mexico built, with cylinder deactivation) vehicles with VINs lower than 3MZBP*****210133 (produced before Dec. 23, 2020)
- 2018-2021 Mazda6 2.5L (with cylinder deactivation) vehicles with VINs lower than JM1GL*****610985 (produced before Feb. 24, 2021)

DESCRIPTION

Some vehicles may have the check engine light on with DTC P0524:00 or P055F:00 stored in memory. Contamination in the engine oil may cause the engine oil solenoid valve to become stuck, resulting in improper operation of the oil pump and improper oil pressure.

- DTC P0524:00 (Engine oil pressure too low)
- DTC P055F:00 (Engine oil pressure malfunction)

CONSUMER NOTICE: The information and instructions in this bulletin are intended for use by skilled technicians. Mazda technicians utilize the proper tools/ equipment and take training to correctly and safely maintain Mazda vehicles. These instructions should not be performed by "do-it-yourselfers." Customers should not assume this bulletin applies to their vehicle or that their vehicle will develop the described concern. To determine if the information applies, customers should contact their nearest authorized Mazda dealership. Mazda North American Operations reserves the right to alter the specifications and contents of this bulletin without obligation or advance notice. All rights reserved. No part of this bulletin may be reproduced in any form or by any means, electronic or mechanical--including photocopying and recording and the use of any kind of information storage and retrieval system ---without permission in writing.

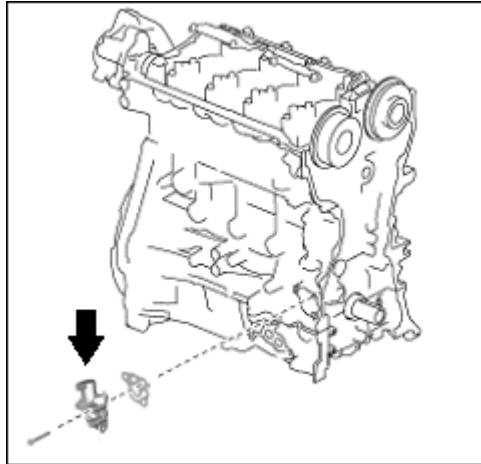

The control software of the PCM has been modified to eliminate this concern. In addition, the production process has been modified to reduce contamination in the engine oil solenoid valve, oil pump, spacer and oil filter.

Customers having this concern should have their vehicle repaired using the following repair procedure.

REPAIR PROCEDURE

1. Verify the customer concern.
2. Replace the engine oil solenoid valve with a new one according to MGSS online:
 - CX-5: (ENGINE OIL SOLENOID VALVE REMOVAL/INSTALLATION [SKYACTIV-G 2.5 (WITH CYLINDER DEACTIVATION)])
 - CX-30: (ENGINE OIL SOLENOID VALVE REMOVAL/INSTALLATION [SKYACTIV-G 2.5 (WITH CYLINDER DEACTIVATION)])
 - Mazda3: (ENGINE OIL SOLENOID VALVE REMOVAL/INSTALLATION [SKYACTIV-G 2.5 (WITH CYLINDER DEACTIVATION)])
 - Mazda6: (ENGINE OIL SOLENOID VALVE REMOVAL/INSTALLATION [SKYACTIV-G 2.5 (WITH CYLINDER DEACTIVATION)])
3. Replace the engine oil and engine oil filter.
4. Reprogram the PCM / ECU with Mazda Modular Diagnostic System (M-MDS) according to:
 - CX-5 / Mazda6: IDS PCM REPROGRAMMING PROCEDURE
 - CX-30 / Mazda3: MDARS/ECU REPROGRAMMING PROCEDURE
5. Verify the repair.

CALIBRATION

CONSUMER NOTICE: The information and instructions in this bulletin are intended for use by skilled technicians. Mazda technicians utilize the proper tools/ equipment and take training to correctly and safely maintain Mazda vehicles. These instructions should not be performed by "do-it-yourselfers." Customers should not assume this bulletin applies to their vehicle or that their vehicle will develop the described concern. To determine if the information applies, customers should contact their nearest authorized Mazda dealership. Mazda North American Operations reserves the right to alter the specifications and contents of this bulletin without obligation or advance notice. All rights reserved. No part of this bulletin may be reproduced in any form or by any means, electronic or mechanical--including photocopying and recording and the use of any kind of information storage and retrieval system ---without permission in writing.

CX-5:

Model	Drive	File Name	Note
2018 CX-5	2WD	PYFA-188K2-L	Mitsubishi
		PYFB-188K2-L	Denso
	4WD	PYFC-188K2-L	Mitsubishi
		PYFD-188K2-L	Denso
2019 CX-5	2WD	PX42-188K2-E	Mitsubishi
		PX43-188K2-E	Denso
	4WD	PX44-188K2-F	Mitsubishi
		PX45-188K2-F	Denso
2020-2021 CX-5	2WD	PX2E-188K2-E	Mitsubishi
		PX2F-188K2-E	Denso
	4WD	PX2G-188K2-E	Mitsubishi
		PX2H-188K2-E	Denso

MAZDA3:

Model	Factory	Transmission	Drive	File Name	Note
2019-2020 Mazda3	Japan Built	A/T	2WD	PX05-188K2-P	Mitsubishi
				PX06-188K2-P	Denso
			4WD	PX07-188K2-S	Mitsubishi
				PX08-188K2-S	Denso
2019-2021 Mazda3	Mexico Built	A/T	2WD	PX58-188K2-N	Mitsubishi
				PX59-188K2-N	Denso
			4WD	PX13-188K2-J	Mitsubishi
				PX14-188K2-J	Denso
4WD	PX15-188K2-J	Mitsubishi			
	PX16-188K2-J	Denso			

CX-30:

Model	Transmission	Drive	File Name	Note
2020-2021 CX-30	A/T	2WD	PXH7-188K2-G	Mitsubishi
			PXH8-188K2-G	Denso
		4WD	PXJ9-188K2-G	Mitsubishi
			PXK1-188K2-G	Denso

CONSUMER NOTICE: The information and instructions in this bulletin are intended for use by skilled technicians. Mazda technicians utilize the proper tools/ equipment and take training to correctly and safely maintain Mazda vehicles. These instructions should not be performed by "do-it-yourselfers." Customers should not assume this bulletin applies to their vehicle or that their vehicle will develop the described concern. To determine if the information applies, customers should contact their nearest authorized Mazda dealership. Mazda North American Operations reserves the right to alter the specifications and contents of this bulletin without obligation or advance notice. All rights reserved. No part of this bulletin may be reproduced in any form or by any means, electronic or mechanical--including photocopying and recording and the use of any kind of information storage and retrieval system ---without permission in writing.

MAZDA6:

Model	File Name
2018 Mazda6	PYH3-188K2-M
2019-2020 Mazda6	PXD8-188K2-D
2021 Mazda6	PX4F-188K2-C

PARTS INFORMATION

Parts Number	Description	Qty.	Notes
PYFA-14-440C	VALVE,OIL CONTROL	1	CX-5, Mazda6 and Mazda3 (Japan built)
P5PW-14-440	VALVE,OIL CONTROL	1	CX-30 and Mazda3 (Mexico built)
PY8W-14-365	GASKET	1	[R]
PY8W-14-275	BOLT	3	[R]
1WPE-14-302	CARTRIDGE,OIL FILTER	1	---

[R]: Replacement parts

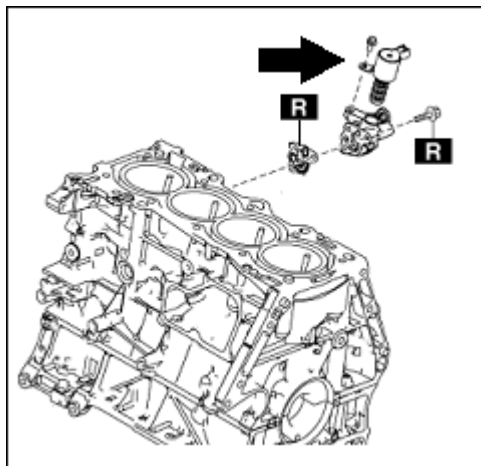
**WARRANTY INFORMATION****NOTE:**

- This warranty information applies only to verified customer complaints on vehicles eligible for warranty repair.
- This repair will be covered under Mazda's New Vehicle Fed. Emission Warranty, Calif. Emission Warranty (short term).
- Additional diagnostic time cannot be claimed for this repair.

CONSUMER NOTICE: The information and instructions in this bulletin are intended for use by skilled technicians. Mazda technicians utilize the proper tools/ equipment and take training to correctly and safely maintain Mazda vehicles. These instructions should not be performed by "do-it-yourselfers." Customers should not assume this bulletin applies to their vehicle or that their vehicle will develop the described concern. To determine if the information applies, customers should contact their nearest authorized Mazda dealership. Mazda North American Operations reserves the right to alter the specifications and contents of this bulletin without obligation or advance notice. All rights reserved. No part of this bulletin may be reproduced in any form or by any means, electronic or mechanical--including photocopying and recording and the use of any kind of information storage and retrieval system ---without permission in writing.

Warranty Type	A
Symptom Code	6X
Damage Code	9W
Part Number Main Cause	5555-RP-PCM (CX-5 / Mazda6) 5555-18-881 (CX-30 / Mazda3)
Quantity	0
Operation Number / Labor Hours:	XXT19XFX / 0.8 Hrs.

NOTE: Claim the parts and engine oil as related parts.

CONSUMER NOTICE: The information and instructions in this bulletin are intended for use by skilled technicians. Mazda technicians utilize the proper tools/ equipment and take training to correctly and safely maintain Mazda vehicles. These instructions should not be performed by "do-it-yourselfers." Customers should not assume this bulletin applies to their vehicle or that their vehicle will develop the described concern. To determine if the information applies, customers should contact their nearest authorized Mazda dealership. Mazda North American Operations reserves the right to alter the specifications and contents of this bulletin without obligation or advance notice. All rights reserved. No part of this bulletin may be reproduced in any form or by any means, electronic or mechanical---including photocopying and recording and the use of any kind of information storage and retrieval system ---without permission in writing.