



Service Bulletin

Bulletin No.: 21-NA-050

Date: March, 2021

TECHNICAL

Subject: Paint Chipping or Peeling on Front Fascia, at Interface of Front Fender and Fascia Near Headlamp

Brand:	Model:	Model Year:		VIN:		Engine:	Transmission:
		from	to	from	to		
Cadillac	Escalade Models	2021	2021			All	All
Chevrolet	Suburban Tahoe						
GMC	Yukon Models						

Involved Region or Country	North America, Saudi Arabia, Columbia, Korea
Additional Options (RPOs)	
Condition	

5758465



5758467

Note: Several examples of the paint damage is shown in the graphic above. The call-outs are (1) fender, (2) fascia and (3) headlamp.

Some customers may comment on seeing paint chipping or peeling on the front fascia at interface of front fender and fascia near headlamp.

Cause

The cause of the condition may be a fascia guide bracket stiffness issue.

Correction

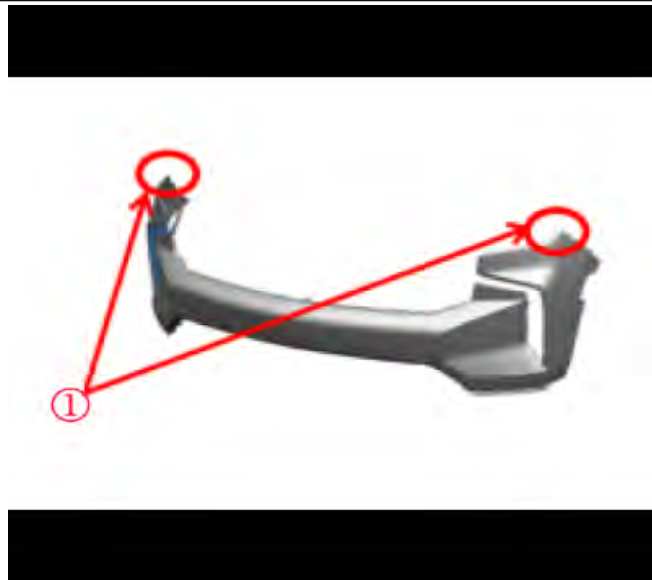

5758469

Note: The area(s) (1) of concern are commonly the rear, upper corners of either, or both sides, of the front fascia.

Remove and reinstall the front fascia, and repair fascia paint as necessary, following the steps in the Service Procedure below.

Service Procedure

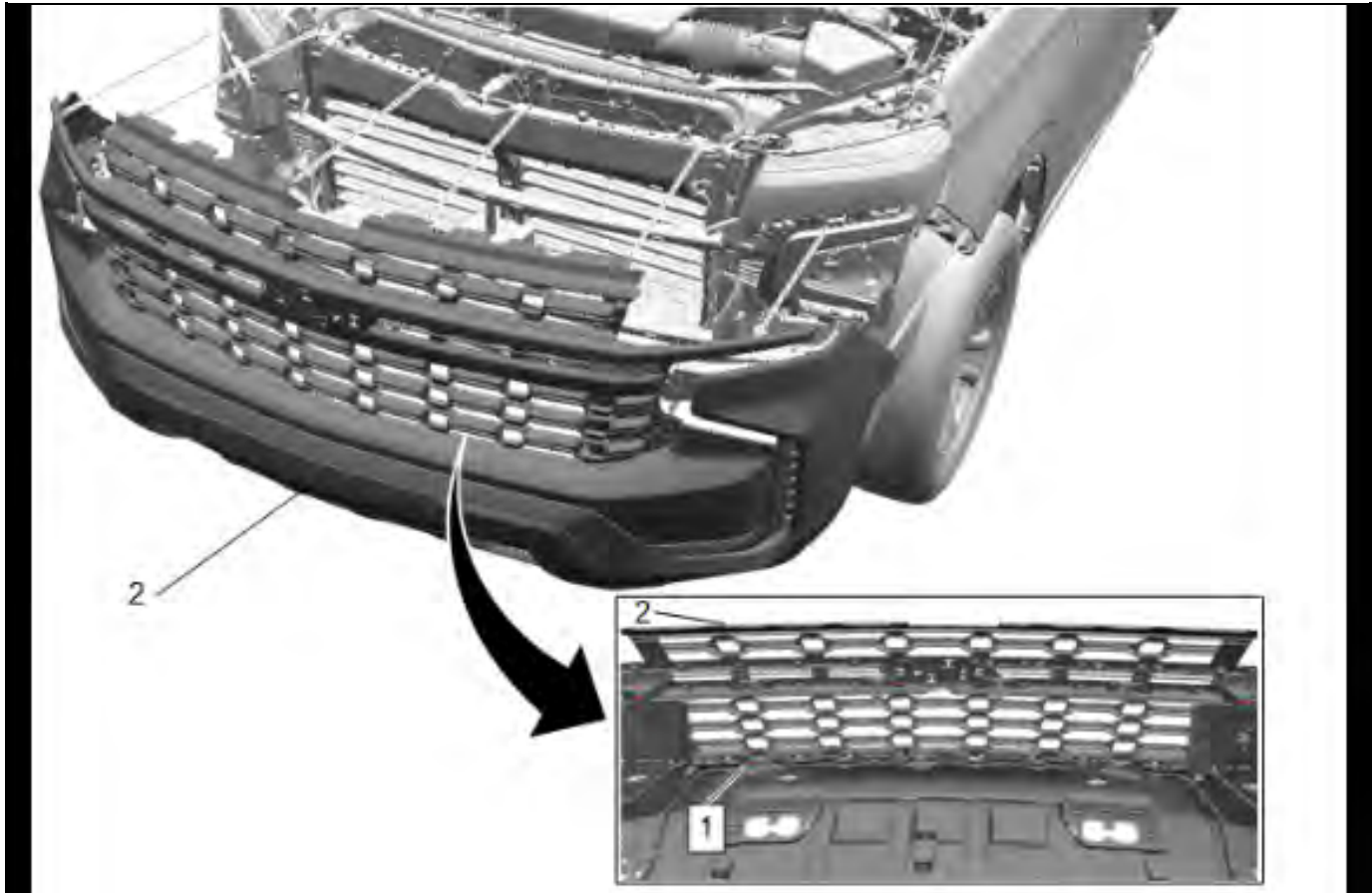

5537676

Note: A Chevrolet model is shown in the graphic above. Other models would be similar.

1. Remove the front fascia (2). Refer to the appropriate *Front Bumper Fascia Removal and Installation*, in SI.

Note: Refer to the latest revision of the GM Approved Refinish Materials book to identify the paint systems you may use that have been engineered to meet GM standards.

The latest revision of the GM Approved Refinish Materials booklet is located on the Genuine GM Parts website at www.genuinegmparts.com and also within the "Unit Repair Manual/Specialty Publication" section of GM Service Information (SI).



5758474

Important: Sand all affected areas smooth to remove paint chip/peel. Sand the outlined area smooth and remove parting line (highlighted in green) to prevent further paint chipping.

2. Complete a partial paint repair to the affected location(s) of the front fascia.

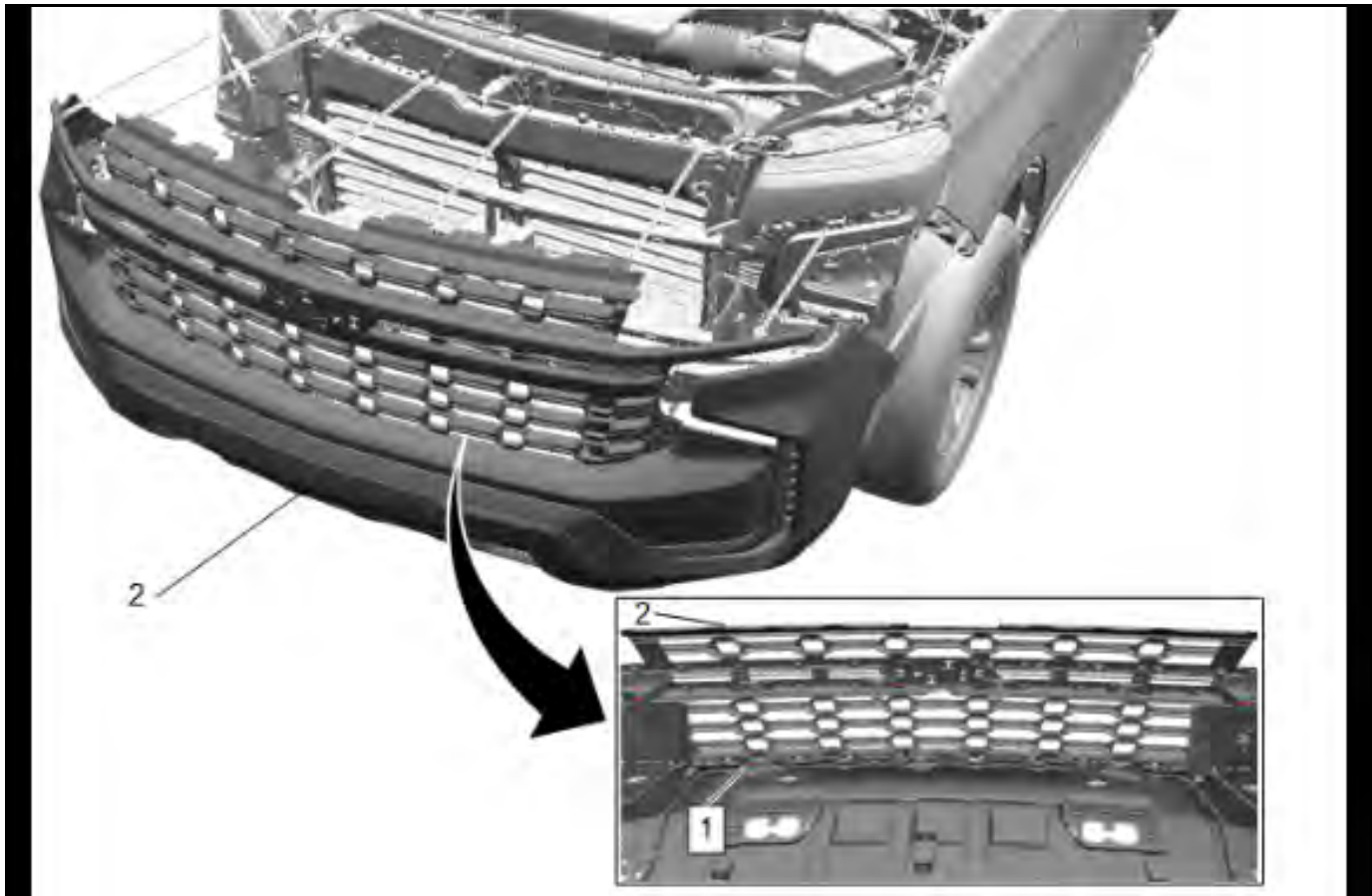

5537676

3. Reinstall the front fascia (2). Refer to the appropriate *Front Bumper Fascia Removal and Installation*, in SI.

Warranty Information

For vehicles repaired under the Bumper-to-Bumper coverage (Canada Base Warranty coverage), use the following labor operation. Reference the Applicable Warranties section of Investigate Vehicle History (IVH) for coverage information.

Labor Operation	Description	Labor Time	Paint Code
1481508*	Remove and Reinstall Front Fascia, Partial Refinish Color/Clear Coat Fascia	Escalade - 3.4 hr** All other Models - 3.1 hr**	Escalade - AP All other Models- AM
Add	With Tint Coat/Tri-Coat Paint	0.3 hr	GC
*This is a unique Labor Operation for Bulletin use only.			
**Includes Paint Mix Time			

Version	1
Modified	Released March 09, 2021

GM bulletins are intended for use by professional technicians, NOT a "do-it-yourselfer". They are written to inform these technicians of conditions that may occur on some vehicles, or to provide information that could assist in the proper service of a vehicle. Properly trained technicians have the equipment, tools, safety instructions, and know-how to do a job properly and safely. If a condition is described, DO NOT assume that the bulletin applies to your vehicle, or that your vehicle will have that condition. See your GM dealer for information on whether your vehicle may benefit from the information.



WE SUPPORT VOLUNTARY
TECHNICIAN
CERTIFICATION