



# Service Bulletin

Bulletin No.: 18-NA-020

Date: March, 2021

## TECHNICAL

**Subject: Malfunction Indicator Lamp Illuminated with DTC P0300 and/or P0299/P2227 Set**

**This Bulletin replaces PIP5511A. Please discard PIP5511A.**

Brand:	Model:	Model Year:		VIN:		Engine:	Transmission:
		from	to	from	to		
Chevrolet	Equinox	2018	2021	-	-	Equipped with 2.0L or 1.5L Engine (RPOs LTG, LYX)	All
GMC	Terrain						

<b>Involved Region or Country</b>	U.S. and Canada
<b>Condition</b>	Some customers may comment on a Malfunction Indicator Lamp illuminated or a reduced power complaint During diagnosis, a technician may find DTC P0299, P2227, or P0300 set/stored.
<b>Cause</b>	This condition may be caused by a moisture build up inside the charge air cooler (CAC). This condition is more likely on the smaller displacement engines where an air-to-air charge air cooler is used. In cold temperatures, ambient and PCV moisture can freeze in the charge air cooler, restricting flow, and causing DTC P0299 and/or P2227, or P0300.
<b>Correction</b>	The correction required will be based on the build of the vehicle, previous repairs that may have been made, and the operating conditions. Use the chart to determine which repair is required. The more severe the cold weather driving conditions, the more operations may need to be implemented. Blocking cold air from the CAC is the main objective to help prevent the moisture from freezing. The first requirement is to ensure there are no leaks in the system from the turbocharger to the throttle body, specifically at the charge air cooler. Perform a smoke leak test (Dealer Essential Tool GE-52250 Power Smoke Diagnostic Leak Detector), then follow the appropriate repair steps, depending on the test results, build date, and outside driving condition temperature. <b>Note:</b> In rare cases where the addition of a charge air cooler shutter doesn't prevent CAC freezing, install the lower portion of the soft grill cover. Inform the customer to remove the cover from the grill when temperatures are consistently averaging 32F/0C or above.

**Note:** If the charge air cooler is not leaking, but is frozen and/or contaminated, remove, thaw, wash it out and reinstall. Use the add-on labor operation.

**Important:** DO NOT replace the CAC inlet or outlet ducts as part of this repair unless there is evidence of damage and/or a leak from either CAC duct.

## Service Procedure - Charge Air Cooler Diagnosis

**Important:** Remove the boost sensor and wipe with a clean rag to remove residual moisture to ensure the sensor is not contaminated. DO NOT use chemical cleaners.

1. Perform a smoke leak test of the charge air cooler, using essential tool GE-52250 Power Smoke Diagnostic Leak Detector.

Refer to Chart Based Conditions, below, for next steps.

Chart Based Conditions						
Model Years	Condition	Replace Charge Air Cooler – (CAC) Refer to Charge Air Cooler Replacement on SI.	Remove Front Bumper Secondary (lower) Shutter	Install Front Bumper Lower (CAC) Shutter, instructions below	Install Soft Grill Cover Over Lower Grill Opening***	Repair Other System Issue
2018-2021	CAC Leaking ONLY	X	-	-	-	-
2018	CAC Frozen (Built Before March 1, 2018) *	X	X	X	Temperature Averages are BELOW 32F/ 0C **	-
2018-2020	CAC Frozen (Built After March 1, 2018) *	-	X	X	Temperature Averages are BELOW 32F/ 0C **	-
2018-2020	CAC Frozen & Leaking	X	X	X	Temperature Averages are BELOW 32F/ 0C **	-
2018-2020 (already had CAC shutter installed)	CAC Frozen AFTER removal of Front Bumper Secondary (lower) Shutter AND Installation of Front Bumper Lower (CAC) Shutter	-	-	-	Temperature Averages are BELOW 32F/ 0C **	-
2021 (has not had CAC shutter installed)	CAC Frozen (Without RPO VRI)	-	X	X	Temperature Averages are BELOW 32F/ 0C **	-
2021	CAC Frozen & Leaking (Without RPO VRI)	X	X	X	Temperature Averages are BELOW 32F/ 0C **	-
2021	CAC Frozen (With RPO VRI)	-	-	-	Temperature Averages are BELOW 32F/ 0C **	-
2021	CAC Frozen & Leaking (With RPO VRI)	X	-	-	Temperature Averages are BELOW 32F/ 0C **	-
2018-2020	CAC Not Frozen or Leaking	-	-	-	-	Refer to SI

**Note:** Replacement of the Charge Air Cooler is ONLY required if GM IVH (View Vehicle Build) indicated build date is before 03/01/2018 AND GM IVH (View Transaction History Detail) indicates the CAC has not been previously replaced.

\*\*\* Remove Soft Grill Cover Over Lower Grill Opening when temperatures are consistently averaging 32F/0C or above.

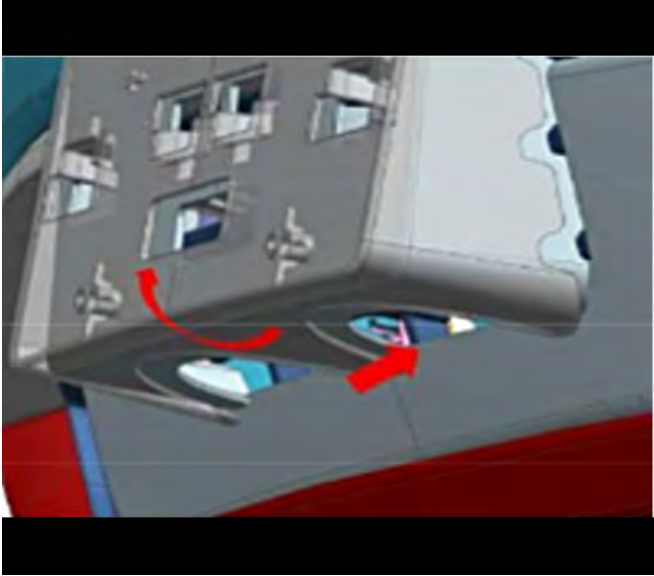
Chart Based Conditions						
Model Years	Condition	Replace Charge Air Cooler – (CAC) Refer to Charge Air Cooler Replacement on SI.	Remove Front Bumper Secondary (lower) Shutter	Install Front Bumper Lower (CAC) Shutter, instructions below	Install Soft Grill Cover Over Lower Grill Opening***	Repair Other System Issue
						
		<p>*** For Terrains with front license plate bracket (VK3), install tape over the openings on bottom of the license plate bracket, to prevent airflow from bypassing the grill cover and flowing directly at the charge air cooler, as shown in the picture above.</p>				

5775941

**Examples of the Differences Between the Shutter Systems**

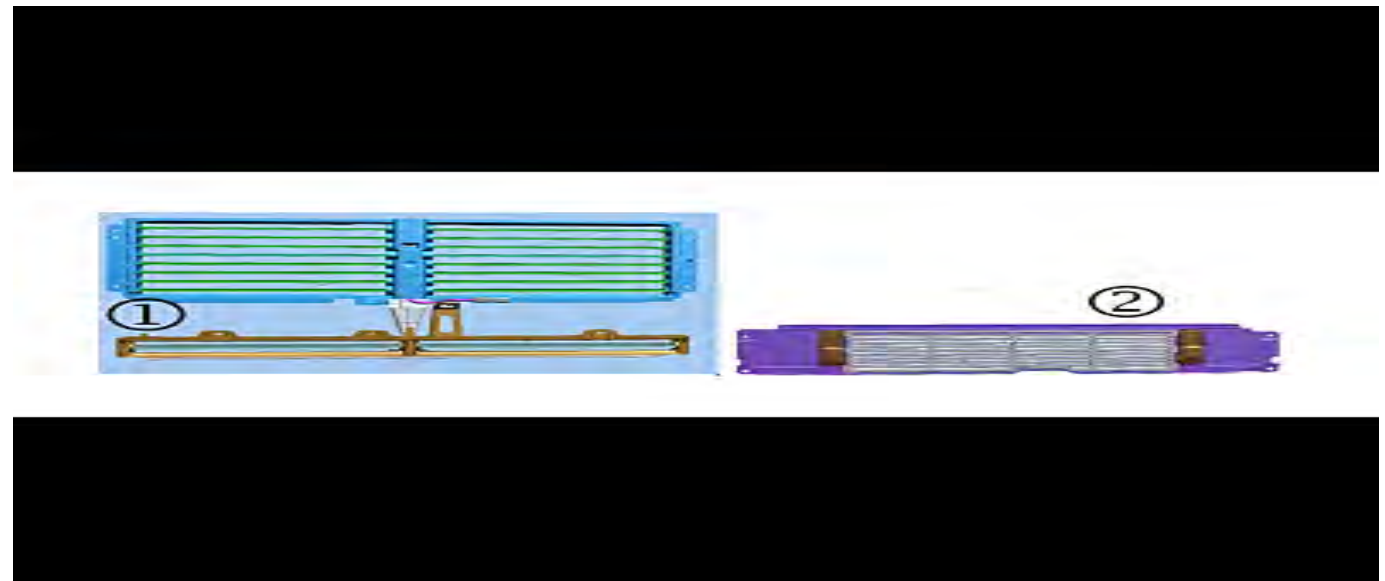

5736482

- Front Bumper Upper Shutter with the Front Bumper Secondary (lower) Shutter attached (1), as shown in the picture above.
- Front Bumper Lower Shutter that mounts in the front of Charge Air Cooler (2), as shown in the picture above.

**Service Procedure - Install Front Bumper Lower (CAC) Shutter**

**Important:** The Front Bumper Lower (CAC) Shutter is a permanently retrofitted item. The added shutter is activated to close and open based on temperature, controlled by integral thermostatic springs.

**Note:** Advise the customer to keep the shutter clear of debris, including leaves and insects. The shutter should be periodically cleaned with a soapy water spray, especially right before the cold weather season begins.

1. Remove the Front Bumper Upper Shutter for modification. Refer to *Front Bumper Shutter Replacement* in SI.
2. Remove and discard the front bumper secondary (lower) shutter assembly from the upper shutter. Refer to *Front Bumper Secondary Shutter Replacement* in SI.

**Note:** The secondary (lower) shutter assembly will NOT need to be reinstalled in the future.

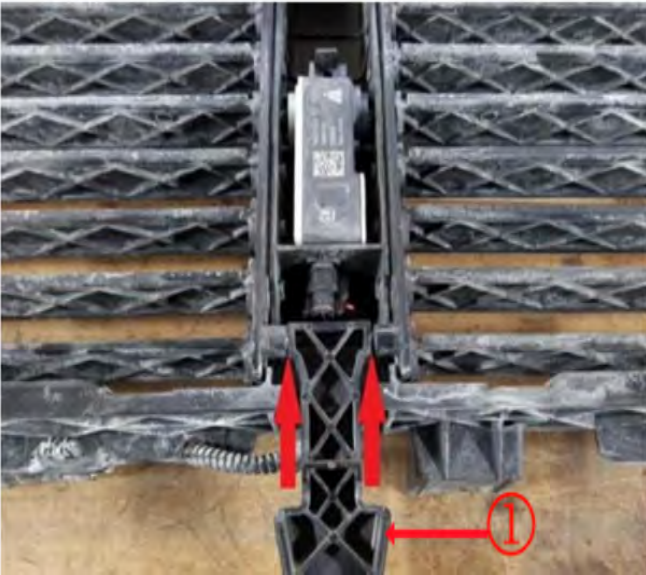

5279924

3. On the back of the now removed upper shutter, using a saw blade, cut the upper shutter to secondary (lower) shutter actuator at the pivot location, as shown in the picture above. Remove the linkage (1) and discard.
4. Reinstall the upper shutter.

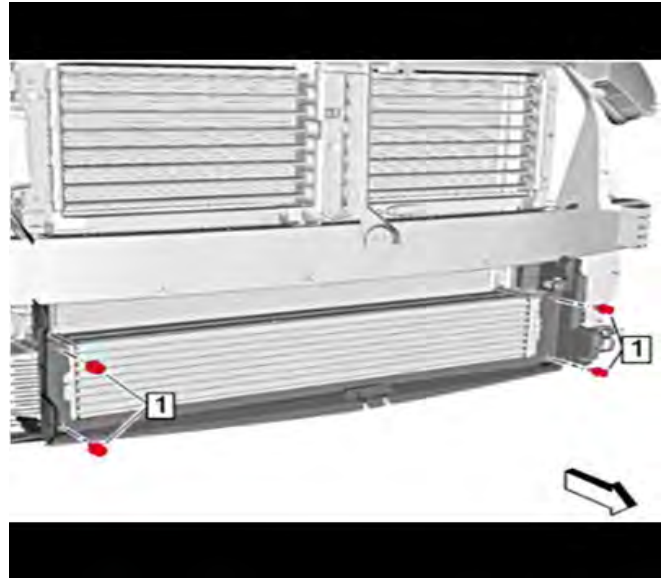

5775942

5. Remove and discard the 4 Lower Air Baffle push-in retainers (1), as shown in the picture above.



5775943

6. Locate Front Bumper Lower (CAC) Shutter in front of the lower air baffle and install the new, longer retainers, as shown in the picture above.
7. Continue reinstalling the parts that were removed during disassembly as part of *Front Bumper Shutter Replacement* in SI.

**Examples of the Grill Opening Covers (Installation instructions included in the part packaging)**



Shown in the picture above are examples of the grill opening covers for the Equinox (1), Terrain without (RPO VK3) (2) and Terrain with (RPO VK3) (3).

\*For warranty transactions, **DO NOT** mark this/these parts as the Causal Part. Enter the word "Bulletin" in the Causal Part Description free-flow text field.

5776421

**Parts Information**

Causal Part	Description	Part Number	RPO
X	Charge Air Cooler	84454110	LYX
		84454111	LTG

Causal Part	Description	Part Number	RPO
NA*	COVER PKG-FRT GRL OPG	84624274 (Equinox)	Without WBL or WFP
		84624275 (Equinox with Redline/Sport)	With WBL or WFP
		84630081 (Terrain without front license plate bracket)	Without VK3
		84648360 (Terrain with front license plate bracket)	With VK3
		84826592 (Equinox)	LTG, LYX
	84826591 (Terrain)		
	SHUTTER KIT - FRT BPR LWR (CAC Shutter)	11589291 x 4	

**Warranty Information**

For vehicles repaired under the Powertrain coverage, use the following labor operation. Reference the Applicable Warranties section of Investigate Vehicle History (IVH) for coverage information.

Labor Operation	Description	Labor Time
4087008*	Perform Smoke Test for Charge Air Cooler and Charge Air Cooler Replacement	2.3 hrs. (Equinox RPO LTG)
		2.4 hrs. (Equinox RPO LYX)
		2.6 hrs. (Terrain RPO LTG)
		2.4 hrs (Terrain RPO LYX)
Add	Install Shutter Cover if also Replacing Charge Air Cooler	0.2 hrs (Equinox, Terrain)
1086018*	Perform Smoke Test and Install Charge Air Cooler Grille Cover	0.6 hrs. (Equinox)
		0.5 hrs. (Terrain)
4087308*	Perform Smoke Test for Charge Air Cooler and Install Shutter Cover	1.3 hrs. (Equinox, Terrain)
Add	Removing and Cleaning Charge Air Cooler if Frozen and/or Contaminated	1.0 hrs. (Equinox, Terrain)

\*This is a unique Labor Operation for Bulletin use only.

Version	14
Modified	<p>Released January 22, 2018</p> <p>Revised July 26, 2018 – Added Holden Equinox Model.</p> <p>Revised October 19, 2018 – Updated the Cause and Correction.</p> <p>Revised December 21, 2018 – Updated Additional Options, Correction, Parts Information and Warranty Information.</p> <p>Revised January 09, 2019 – Updated the Parts Information.</p> <p>Revised February 19, 2019 – Added Envision also updated the Condition, Parts Information and Warranty Information.</p> <p>Revised March 19, 2019 – Updated the Service Procedure and Warranty Information for Equinox/Terrain.</p> <p>Revised May 15, 2019 – Updated the Warranty Information and adding flow chart.</p> <p>Revised November 05, 2019 – Updated the Warranty Information.</p> <p>Revised December 17, 2019 – Added 2020 Model Year.</p> <p>Revised February 21, 2020 – Updated pictures for flow charts, also updated applicable information within the bulletin including the Service Procedure Equinox/Terrain also Part and Warranty Information.</p> <p>Revised April 07, 2020 – Updated information for the following: Correction, Service Procedure (Equinox/Terrain) and Warranty Information.</p> <p>Revised February 11, 2021 – Added 2020-2021 Model Years for Equinox/Terrain, added Examples of the Difference Between the Two Shutters information and updated information under Service Procedure Equinox, Terrain.</p> <p>Revised March 18, 2021 - Removed Buick Envision and updated applicable information throughout the Bulletin.</p>

